



Wheel Speed Sensor For ABS Systems

Preliminary Technical Data

AD22157

FEATURES

Speed and direction from 0Hz to 2500Hz
Air gap diagnostics
2-wire current-loop operation
Wide Operating Temperature Range
Functional during temperature excursions to 190C
Reverse Supply Protected (-30V)

APPLICATIONS

Automotive

Wheel speed and direction sensing
Transmission speed sensing

Industrial

Incremental position sensing
Proximity switching

Functional Block Diagram

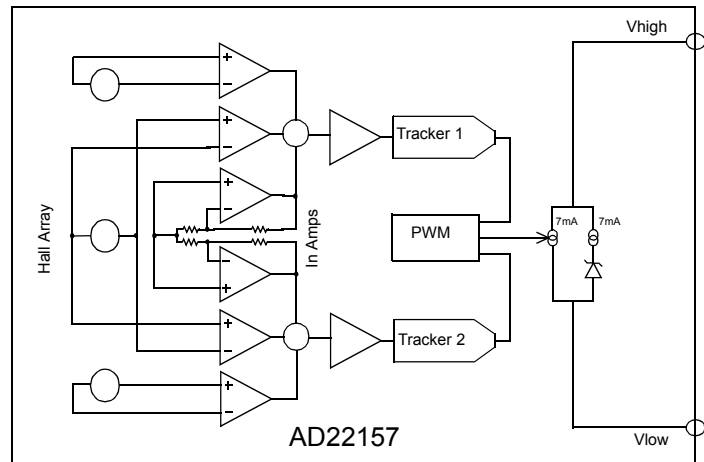

GENERAL DESCRIPTION

The AD22157 is a mixed signal magnetic field transducer designed for applications where both speed sensing and direction sensing of a ferrous target wheel are required over a wide speed range.

The device operates from a 2 wire high compliance current loop and is suitable for continuous operation from -40C to 150C with supplies up to +20 Vdc. The sensor is designed to remain functional during voltage transients up to +27V.

The sensor output format is a current pulse from 7mA to 14mA (the quiescent bias is 7mA) whose rising edge is accurately placed relative to the edges of the target wheel. The pulse width is determined by both target wheel direction and field strength. The output pulse is coded in multiples of a well defined time interval depending on direction and field strength in conformance with industry standards currently being promoted by leading systems manufacturers.

Pulse widths corresponding to differential magnetic fields measured at the sensor of $\Delta B > 4\text{mT}$ (normal operation), $2\text{mT} < \Delta B < 4\text{mT}$ (low field range), and $\Delta B < 2\text{mT}$ (very low field range) are provided. Direction is indicated in the normal and low ranges.

A fail safe stop signal repeating at approximately 1.5Hz is provided initially at power on, if the target wheel is stopped, or if no dynamic signal is detected for some other reason.

The sensor combines integrated bulk Hall cell technology and instrumentation circuitry to minimize temperature related drifts
REV. PrA

Information furnished by Analog Devices is believed to be accurate and reliable. However, no responsibility is assumed by Analog Devices for its use, nor for any infringements of patents or other rights of third parties which may result from its use. No license is granted by implication or otherwise under any patent or patent rights of Analog Devices.

associated with Hall cell characteristics. The sensor is compensated to work optimally with SmCo magnets. The architecture maximizes the advantages of fine line CMOS and high voltage DMOS allowing the device to operate accurately in demanding environments.

Principle features of the AD22157 include an adaptive differential zero crossing detector which accurately determines the position of target wheel edges. This architecture eliminates the effects of package and thermal stress on the Hall sensor array resulting in 2% repeatability of the time interval from rising edge to rising edge of the sensor output.

The sensor takes 4 edges from either power on or a stopped condition to achieve full accuracy. The architecture employs digital signal processing to provide robust functionality and eliminate spurious or missing pulses under extreme conditions of EMC.

The AD22157 is housed in a 5 lead single-in-line (SIP) package suitable for mounting with a back biasing magnet in a typical wheel speed sensor assembly.

One Technology Way, P.O. Box 9106, Norwood, MA02062-9106, USA
www.analog.com

© Analog Devices, Inc., 2001

Preliminary AD22157 - Specifications (TA=+25C and V+=12V unless otherwise noted)

Parameters	Min	Typ	Max	Units
OPERATING TEMPERATURE	-40		150	C
POWER SUPPLY				
Vcc Operating	4.5		20.0	V
Vcc max transient			27.0	
Reverse Supply			-30.0	
SUPPLY CURRENT				
Iout low	5.5	7.0	8.5	mA
Iout high (pulsed)	11.0	14.0	17.0	
OUTPUT CURENT RATIO	1.8	2	2.2	
OUTPUT CURRENT PULSE WIDTH ¹				
Nominal field operation (left/right)	72/144	90/180	108/216	uS
Low field operation (left/right)	288/576	360/720	432/664	
Air gap limit	36	45	54	
No field or stopped for >737mS	1152	1440	1728	
PULSE PERIOD IN STOPPED MODE	589	737	884	mS
THRESHOLDS FOR OPERATION MODES				
Nominal field threshold		4<Bth		mT
Low field threshold		2<Bth<4		
Field too low threshold		Bth<2		
POWER ON TIME		4		mS
CALIBRATION CYCLE		4		edges
CALIBRATION UPDATE CYCLE		each edge		
TIMING ACCURACY ²		2		%

NOTES

1 Left: wheel moving from pin 1 to pin 5 with the front of the AD22157 facing the wheel (see figure 7).

2 Timing wheel with 2.5mm tooth/2.5mm valley and 5mmx4mm SmCo magnet.

ABSOLUTE MAXIMUM RATINGS*

Maximum Supply Voltage +27 V
 Maximum Output Current (Pin 2) 18 mA
 Operating Temperature Range -40°C to +150°C
 Die Junction Temperature +190°C
 Storage Temperature Range -65°C to +160°C
 Lead Temperature (Soldering, 10 sec) +300°C

*Stresses above those listed under “Absolute Maximum Ratings” may cause permanent damage to the device. This is a stress rating only and functional operation of the device at these or any other conditions above those listed in the operational sections of this specification is not implied. Exposure to absolute maximum rating conditions for extended periods may affect device reliability.

Pin Configuration

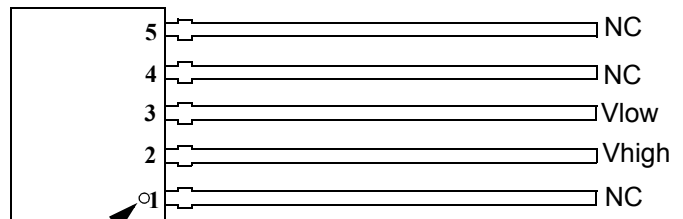

PIN 1 IDENTIFIER

CAUTION

ESD (electrostatic discharge) sensitive device. Electrostatic charges as high as 4000 V readily accumulate on the human body and test equipment and can discharge without detection. Although the AD22157 features proprietary ESD protection circuitry, permanent damage may occur on devices subjected to high energy electrostatic discharges. Therefore, proper ESD precautions are recommended to avoid performance degradation or loss of functionality.



CIRCUIT OPERATION

The AD22157 is a two wire current modulating transducer which generates current pulses in response to spacial differential changes in a magnetic field. A typical application is wheel speed sensing where the field to be sensed is generated by the interaction of a permanent magnet behind the sensor and a notched or hole stamped ferromagnetic target wheel in front of the sensor. Under these conditions the sensor must reject that portion of the 'bias' field which is constant, and amplify the remaining differentially modulated portion of the field and determine accurately the position of edge transitions on the wheel.

SIGNAL DETECTION

The bias field rejection is accomplished by a spacial differential measurement of the field using integrated Hall plate structures within the silicon substrate. A linear array of three Hall cells is used. The AD22157 is designed to give optimum quadrature signals at a tooth/ notch pitch of 5mm.

Each of the three Hall devices is constructed of four individual plates of 200um diameter connected in parallel and spatially oriented in each of four cross quadrature positions in order to relieve

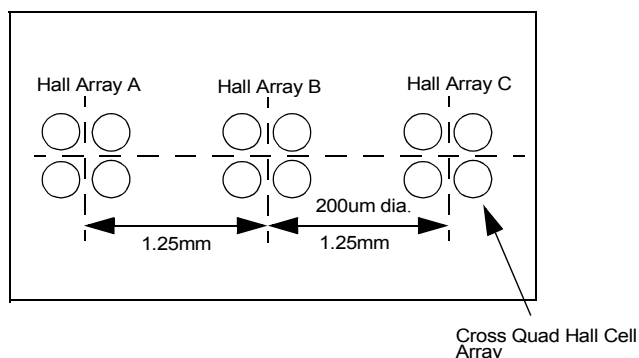

Figure 1. AD22157 Hall Array Spacing

process gradient induced offsets in the Hall signal voltage.

The Hall plate arrays are biased by three matched current sources. The sensitivity of the plates to magnetic field is 5uV / Gauss at this

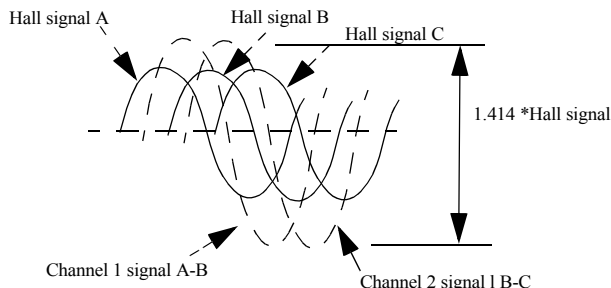

Figure 2. Quadrature Fields Sensed By Hall Array

current. The three Hall effect sensors are connected to instrumentation amplifiers as two pairs with the center plate shared between the two amplifiers. In this configuration two spacial differential magnetic signals are transformed into electrical signals whose peak to peak amplitude is directly proportional to the differential magnetic field component and the Hall plate bias current.

Pitch matching the Hall array to the wheel results in an approximately sinusoidal field variation being sensed by the spatial differential array.

SOURCES OF ERROR PRIOR TO SIGNAL CONDITIONING

The Hall sensors generate a number of error components in addition to the desired spatial differential signal:

Uncompensated magnetic bias field due to mismatch of Hall plate sensitivities, Hall bias current mismatch and variations in magnetic flux density across the surface of the bias magnet.

Intrinsic Hall plate offset due to lithographic misalignment of Hall plate contacts, local planar variations in Hall plate diffusion due to manufacturing tolerances and mechanical stress imposed by encapsulation.

Temperature dependent sensitivity of the Hall cells is approximately +450 ppm/ C.....(+/-150 ppm / C).

Temperature dependent components of offsets are beyond the scope of this functional description, however it may be assumed that their total contribution at the output of the pre amplifiers is in the order of several hundred millivolts, which may drift with temperature by tens of millivolts in either direction.

From a circuit perspective, the amplifiers will contribute further input referred offset to the signals. This component is less than 1 mV and typically is of the order of several hundred micro volts.

SIGNAL CONDITIONING

The primary function of the signal conditioning is to compensate for offset errors and accurately determine the zero crossings of the differential Hall cell signal component. The differential signals approximate quadrature sine waves whose frequency is determined by the rotational speed of the target wheel. The phase relationship of the quadrature signal is used to determine the direction of wheel rotation.

Two separate measurement channels are used for signal conditioning. The first channel circuitry (Tracker1) is used to determine the zero crossing information and is the primary source of edge information. The second channel (Tracker2) is used only for obtaining direction information by comparison of signal phase. Each channel comprises two infinite sample hold circuits built around ten bit tracking analog to digital converters.

Peak detection of each of the channel signals is performed by Tracker1 and Tracker2 using two A/D converter based sample hold circuits per Tracker. One sample hold circuit follows positive peaks, the other negative peaks. The potentials of the DAC's represent the positive and negative peak values of the signal at any given time.

AD22157

The mid point of these potentials is used as a reference for a zero crossing detector in the PWM. This system assures that a phase jitter specification of +/- 2% for 1kHz signal (rising edge to rising edge) can be met over all operational conditions.

Tracker1 also makes an absolute measurement of peak to peak signal. The digital result is a measure of field strength which can be related directly to air gap or used for diagnostic purposes in the application. The digital result is combined with direction information from Tracker 2 and used to program the output pulse width modulator (PWM).

The absolute peak to peak value of the Hall signal may vary due to air gap settings and alter dynamically due to wheel run out. A fixed resolution converter may fail to maintain acquisition of the signal peaks using only single 1lsb steps. To compensate for this, the resolution of the converters adapts to changes in the signal that cannot be followed using 1lsb steps.

HALL PLATE BIAS

The Hall cells are biased so that the temperature coefficient of sensitivity of the AD22157 is of similar magnitude but opposite polarity to rare earth magnetic materials i.e. SmCo = - 450ppm/C. or Alnico 5 -7 = -300 ppm/C. This results in good stability of the PWM thresholds.

OPERATIONAL MODES

On receipt of a power on reset or a stopped or no field condition the sample hold circuits in each tracker channel reset to their maximum and minimum voltages. They then track inwards until the Hall signal is acquired.

Tracker1(S/H_max) increments to the most positive Hall signal peak, Tracker1(S/H_min) decrements to negative peaks.

Four zero crossing events are required to ensure Hall signal peak acquisition. No output edges are enabled during this time. On the third zero crossing after the reset condition the acquire mode of operation is disabled. The DAC signals are then coincident with the peak values of the Hall signal. After the four zero crossing delay, the converters enter dither mode. This mode of operation keeps the DAC voltages at the peaks of the Hall signal and maintains a valid zero crossing in the presence of run out and offset drift.

PWM AND OUTPUT STAGE

The pulse width modulator is the final stage of the signal conditioning. Its primary function is to convert the Hall signal information of zero crossings, signal amplitude, and direction, into a single bit pulse width modulated signal.

The leading edge of the pulse is determined by a zero crossing event from Tracker 1. The duration of the pulse is determined by direction and signal amplitude. (See Fig. 4 and 5)

All events within the signal conditioning are synchronized to the internal clock. Asynchronous zero cross events are aligned to the following clock edge which results in a maximum delay of 1.4 us. Output pulse widths are modulated by means of a 19 bit counter. The counter functions both as a pulse width modula-

tor and watchdog timer.

The timing sequence is as follows:

- i. The counter is reset upon receipt of a zero crossing event.
- ii. The leading edge of the pulse is output after a delay of 45uS.
- iii. Amplitude thresholds are decoded with direction and the appropriate output pulse width is generated.
- iv. The counter is reset.
- v. If a zero crossing is not received before the counter overflows (745 uS), a STOP pulse is output.

The purpose of resetting the trackers is to enable the offset correction circuitry to remain active when no zero crossing events occur but when thermally induced drift may invalidate the offset correction over extended periods of inactivity.

The sensor supply loop current is modulated in response to the pulse input between two discrete current levels of approximately 7 mA and 14 mA. The lower current value being the quiescent or logic low state.

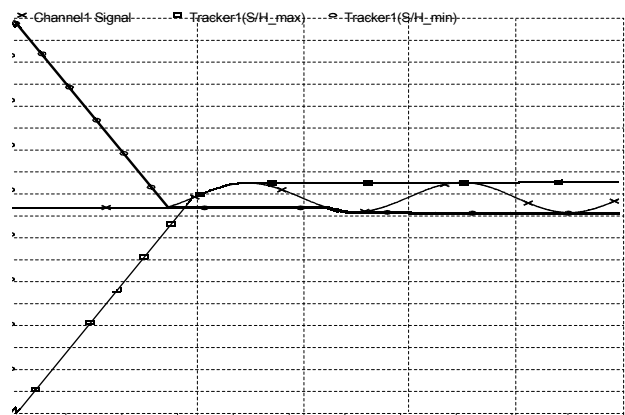

Figure 3. Signal Acquisition From a Power On or Stopped (no field) Condition

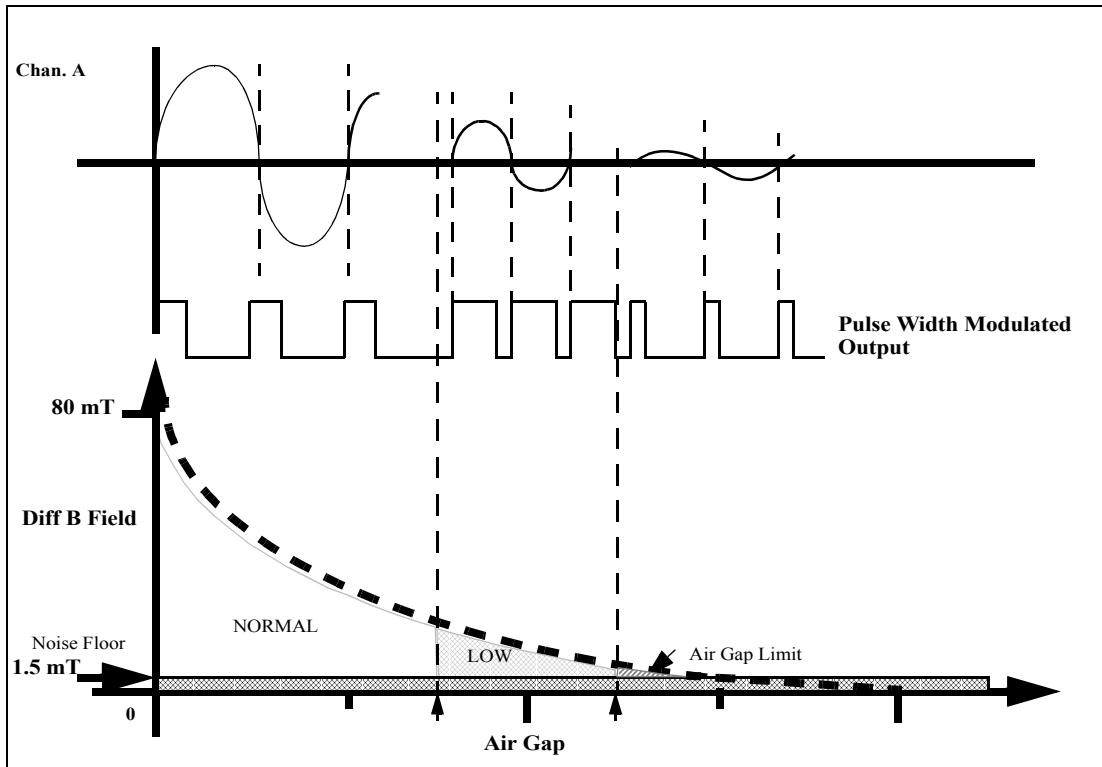

Figure 4. AD22157 Output Signal / Field Relationship

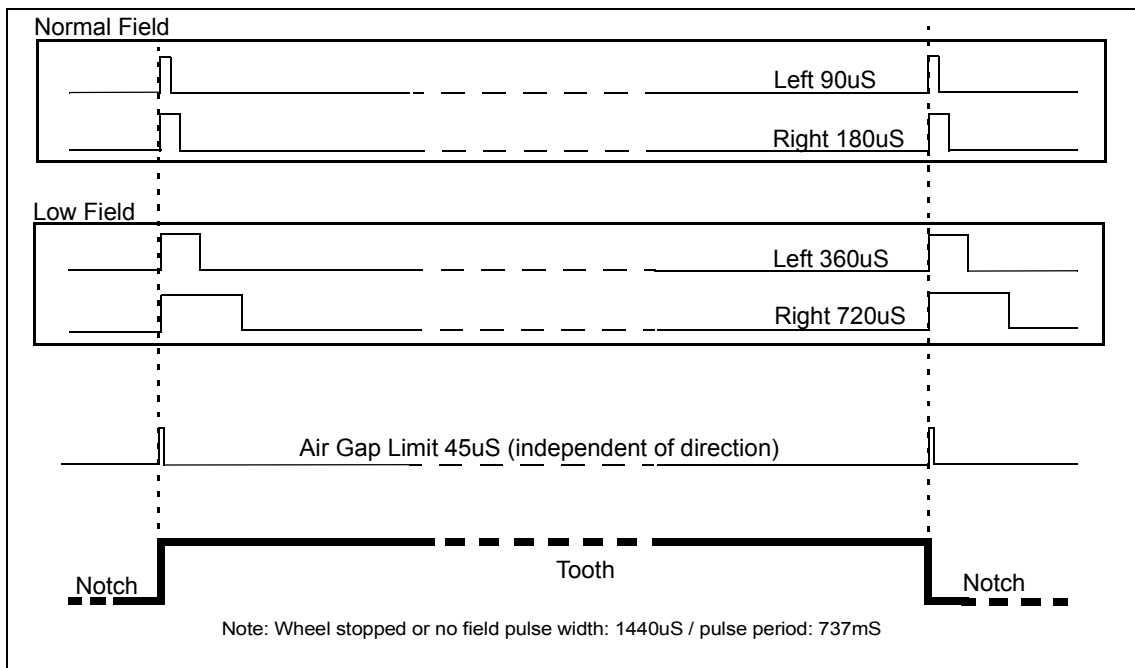

Figure 5. AD22157 PWM vs. Field and Direction of Wheel Rotation

AD22157

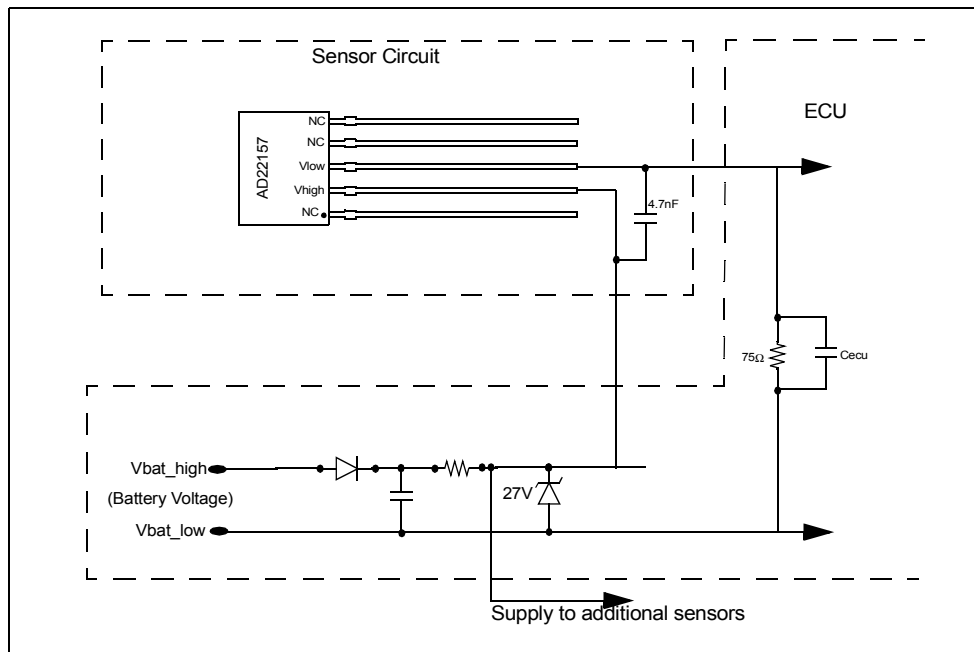

Figure 6. Typical Connection in a Wheel Speed Sensing Application

A typical automotive application is shown above. The digital output signal is developed across a 75 ohm resistor. The power supply to the device is conditioned in an ECU to limit “load dump” pulses to 27v.

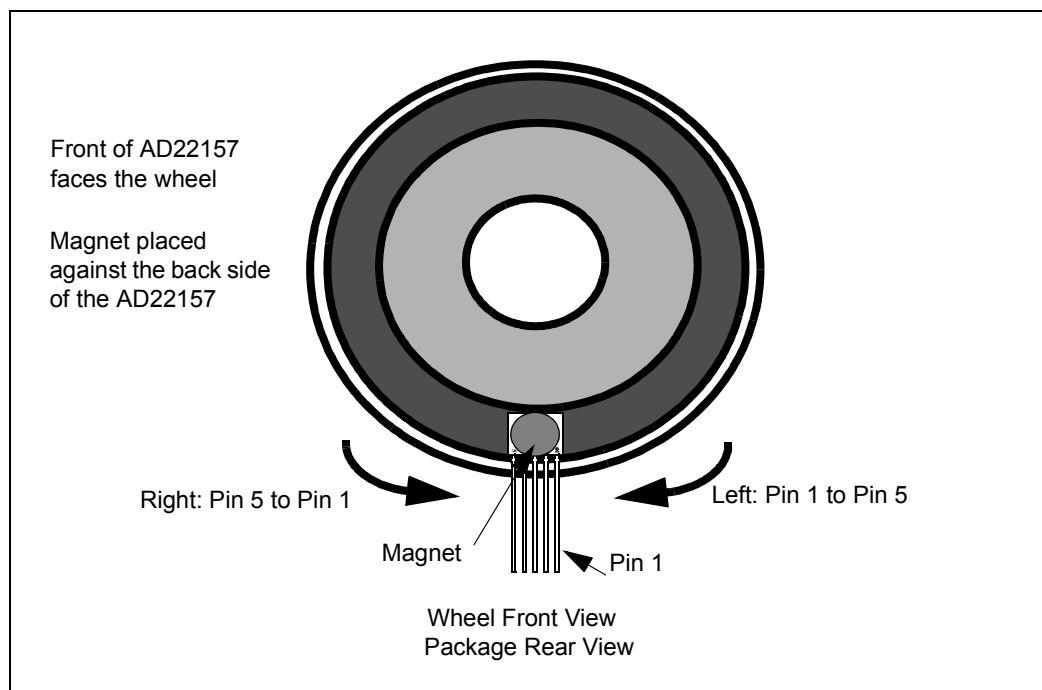

Figure 7. Wheel Direction Diagram

Outline Dimensions

Dimensions shown in mm and (inches)

