

2-Vrms Cap-Less Line Driver with Adjustable Gain

Features

- Operation Voltage: 3V to 3.6V
- Cap-less Output
 - Eliminates Output Capacitors
 - Improves Low Frequency Response
 - Reduces POP/Clicks
- Low Noise and THD
 - Typical SNR 107dB
 - Typical V_n 7 μ Vrms
 - Typical THD+N < 0.02%
- Maximum Output Voltage Swing into 2.5k Load
 - 2Vrms at 3.3V Supply Voltage
- single-ended Input
- External Gain Setting from 1V/V to 10V/V
- Fast Start-up Time : 0.5ms
- Integrated De-Pop Control
- Thermal Protection
- Less External Components Required
- +/-8kV IEC ESD Protection at line outputs

Applications

- LCD / PDP TVs
- CD / DVD players
- Set-Top Boxes
- Home Theater in Box

Description

The AD22657B is a 2-Vrms cap-less stereo line driver. The device is ideal for single supply electronics. Cap-less design can eliminate output dc-blocking capacitors for better low frequency response and save cost.

The AD22657B is capable of delivering 2-Vrms output into a 10k Ω load with 3.3V supply. The gain settings can be set by users from 1V/V to 10V/V externally. The AD22657B build-in shutdown control and de-pop control sequence also help AD22657B to be a pop-less device.

The AD22657B is available in a 10-pin MSOP package.

Ordering Information

Product ID	Package	Packing	Comments
AD22657B-MH10NAT	MSOP-10	80 Units / Tube	Green(HF)
AD22657B-MH10NAR		100 Tubes / Small Box	
		3k Units Tape & Reel	

Simplified Application Circuit

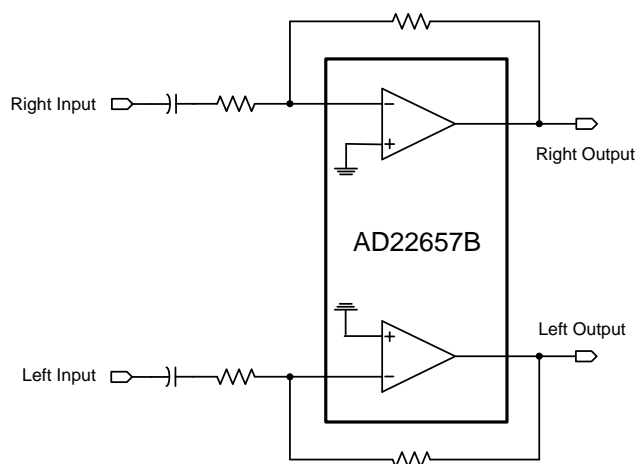

Pin Assignments

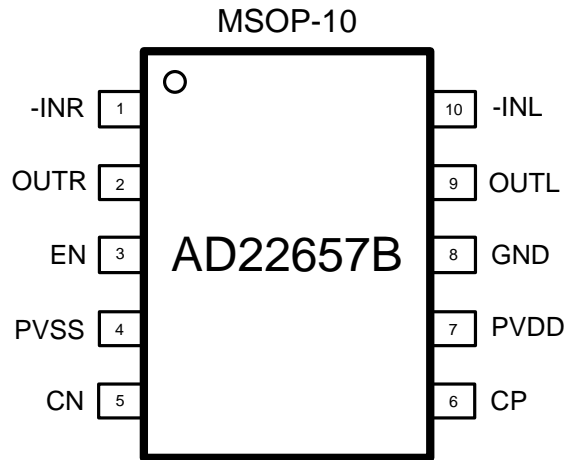

Pin Description

No.	Name	Type ⁽¹⁾	Pin Description
1	-INR	I	Right channel OP negative input
2	OTR	O	Right channel OP output
3	EN	I	Enable input, active high
4	PVSS	P	Supply voltage
5	CN	I/O	Charge-pump flying capacitor negative terminal
6	CP	I/O	Charge-pump flying capacitor positive terminal
7	PVDD	P	Positive supply
8	GND	P	Ground
9	OUTL	O	Left channel OP output
10	-INL	I	Left channel OP negative input

(1) I=input, O=output, P=power

Functional Block Diagram

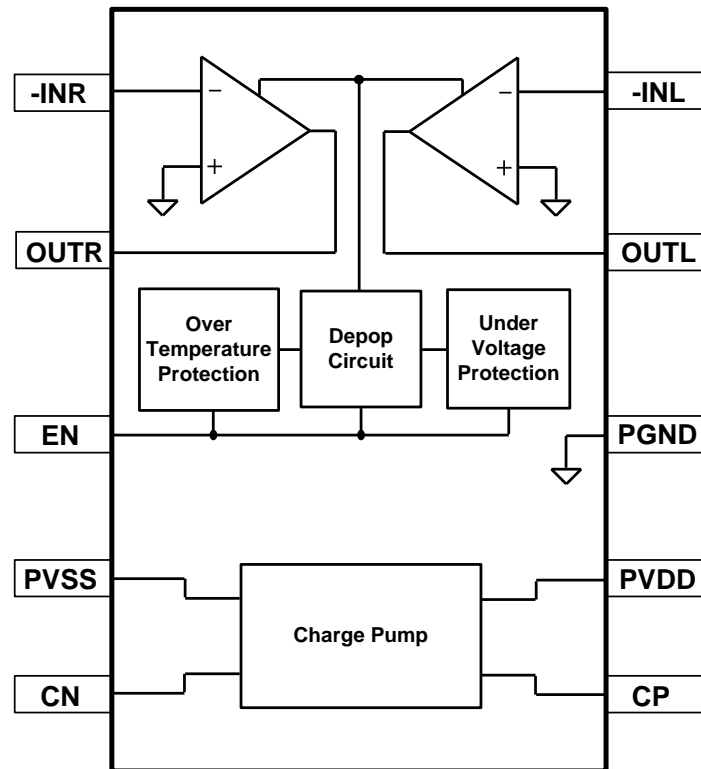

Available Package

Package Type	Device No.	θ_{ja} (°C/W) ⁽¹⁾	θ_{jc} (°C/W) ⁽²⁾
MSOP-10	AD22657B	120	45

(1) θ_{ja} is measured at room temperature (TA=25°C), natural convection environment test board, which is constructed with a thermal efficient, 2-layers PCB. The measurement is tested using the JEDEC51-3 thermal measurement standard.

(2) θ_{jc} represents the heat resistance for the heat flow between the chip and package's top surface.

Marking Information

AD22657B

Line 1 : LOGO

Line 2 : Product No.

Line 3 : Tracking Code

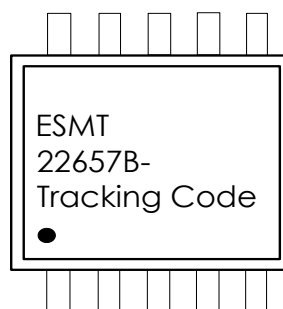

Absolute Maximum Ratings ⁽¹⁾

SYMBOL	PARAMETER	VALUE	UNIT
	Supply Voltage, V _{DD} to GND	-0.3 to 3.6	V
V _I	Input Voltage	VSS -0.3 to VDD+0.3	V
R _L	Minimum load impedance	> 600	Ω
	EN to GND	-0.3 to VDD+0.3	V
T _{stg}	Storage temperature range	-65 to 150	°C
T _J	Maximum operating junction temperature range	-40 to 150	°C

(1) The absolute maximum ratings are limiting values of operation, safety of the device cannot be guaranteed if beyond those values.

Recommended Operating Conditions

SYMBOL	PARAMETER	Min	NOM	Max	UNIT
V _{DD}	Supply Voltage	3.0	3.3	3.6	V
V _{IH}	High Level Input Voltage		60		% of V _{DD}
V _{IL}	Low Level Input Voltage		40		% of V _{DD}
T _A	Operating Ambient Temperature Range	-40		85	°C
R _L	Load Resistance	600			Ω

Electrical Characteristics

PVDD=3.3V, T_A=25°C, R_L=2.5kΩ, C_{FLY}=C_{PVSS}=1μF, C_{IN}=1μF, R_I=10kΩ, R_F=20kΩ (unless otherwise noted)

SYMBOL	PARAMETER	TEST CONDITIONS	Min	NOM	Max	UNIT
I _{DD}	V _{DD} Supply Current	EN=V _{DD}		7	15	mA
I _{SD}	V _{DD} Shutdown Current	EN=0V, V _{DD} =3.3V			5	μA
I _I	Input Current	EN pin		0.1		μA
V _O	Output Voltage (Outputs In Phase)	THD+N=1%, V _{DD} =3.3V, f _{IN} =1kHz	2.0	2.3		V _{rms}
THD+N	Total Harmonic Distortion Plus Noise	V _O =2V _{rms} , f _{IN} =1kHz		0.004		%
Crosstalk	Channel Separation	V _O =2V _{rms} , f _{IN} =1kHz		98		dB
V _N	Output Noise	R _I =10k, R _F =10k		7	15	μV _{rms}

Electrical Characteristics (Con't)

PVDD=3.3V, T_A=25°C, R_L=2.5kΩ, C_{FLY}=C_{PVSS}=1μF, C_{IN}=1μF, R_I=10kΩ, R_F=20kΩ (unless otherwise noted)

SYMBOL	PARAMETER	TEST CONDITIONS	Min	NOM	Max	UNIT
V _{SR}	Slew Rate			8		V/μs
SNR	Signal to Noise Ratio	V _O =2Vrms, R _I =10k, R _F =10k, A-weighted		107		dB
G _{BW}	Unit-Gain Bandwidth			8		MHz
A _{VO}	Open-Loop Gain		80			dB
V _{OS}	Output Offset Voltage	V _{DD} =3V to 3.6V, Input Grounded	-1		1	mV
PSRR	Power Supply Rejection Ratio	V _{DD} =3V to 3.6V, V _{rr} =200mVrms, f _{IN} =1kHz		-80	-60	dB
R _I	Input Resistor Range		1	10	47	kΩ
R _F	Feedback Resistor Range		4.7	20	100	kΩ
f _{CP}	Charge-Pump Frequency		400	500	600	kHz
	Maximum capacitive Load			220		pF
TSD	Over Temperature Protection Level			150		°C
T _{start-up}	Start-up Time			0.5		ms

Typical Characteristics

PVDD=3.3V, $T_A=25^\circ\text{C}$, $R_L=10\text{k}\Omega$, $C_{FLY}=C_{PVSS}=1\mu\text{F}$, $C_{IN}=1\mu\text{F}$, $R_I=10\text{k}\Omega$, $R_F=20\text{k}\Omega$ (unless otherwise noted)

- Total Harmonic Distortion + Noise (THD+N) vs. Output Power

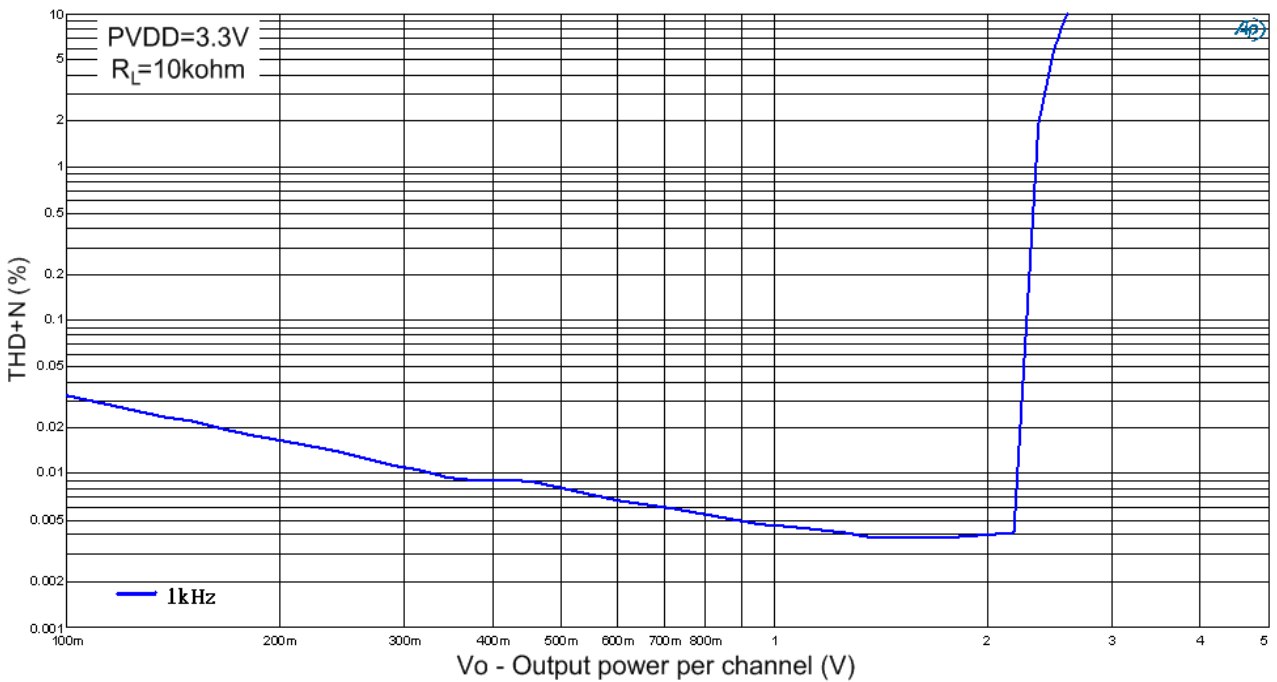
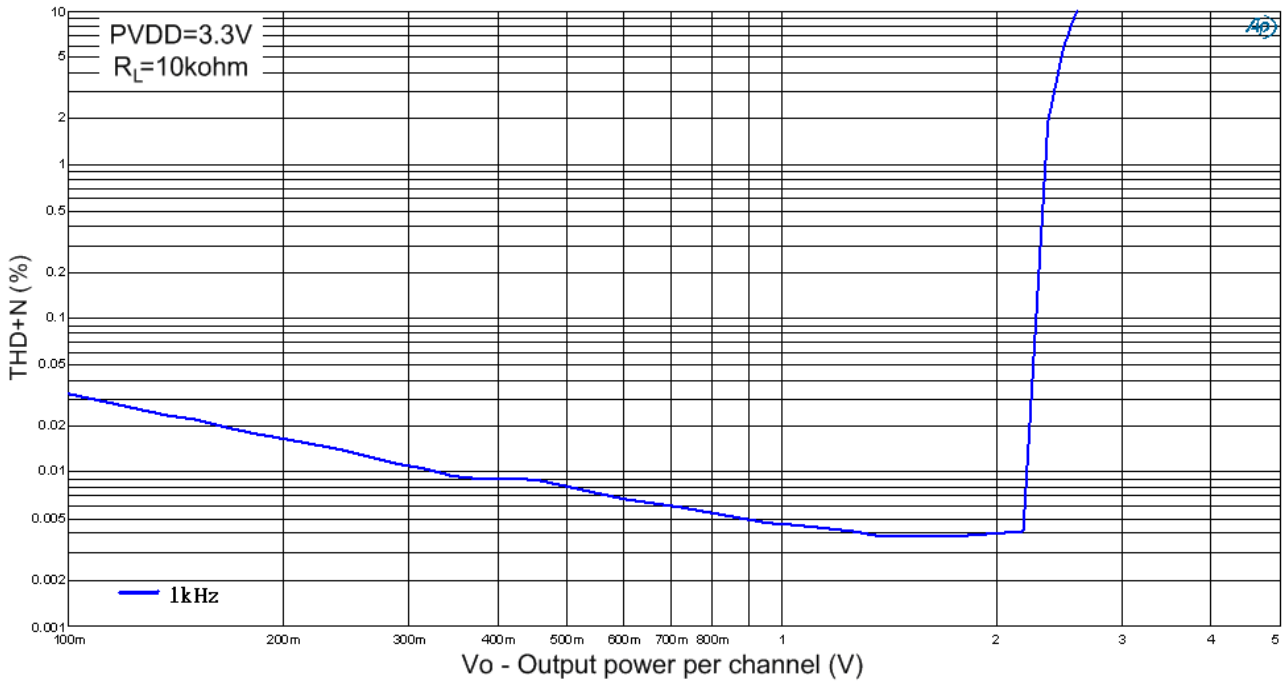

- Total Harmonic Distortion + Noise (THD+N) vs. Signal Frequency

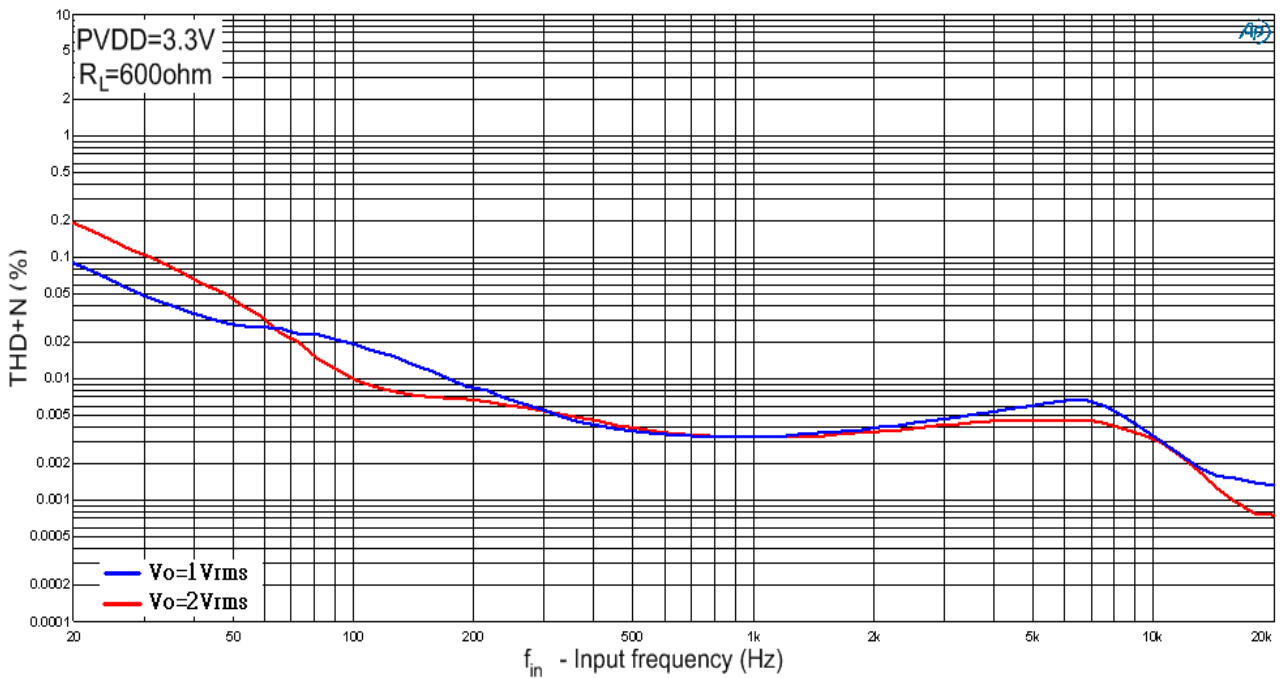
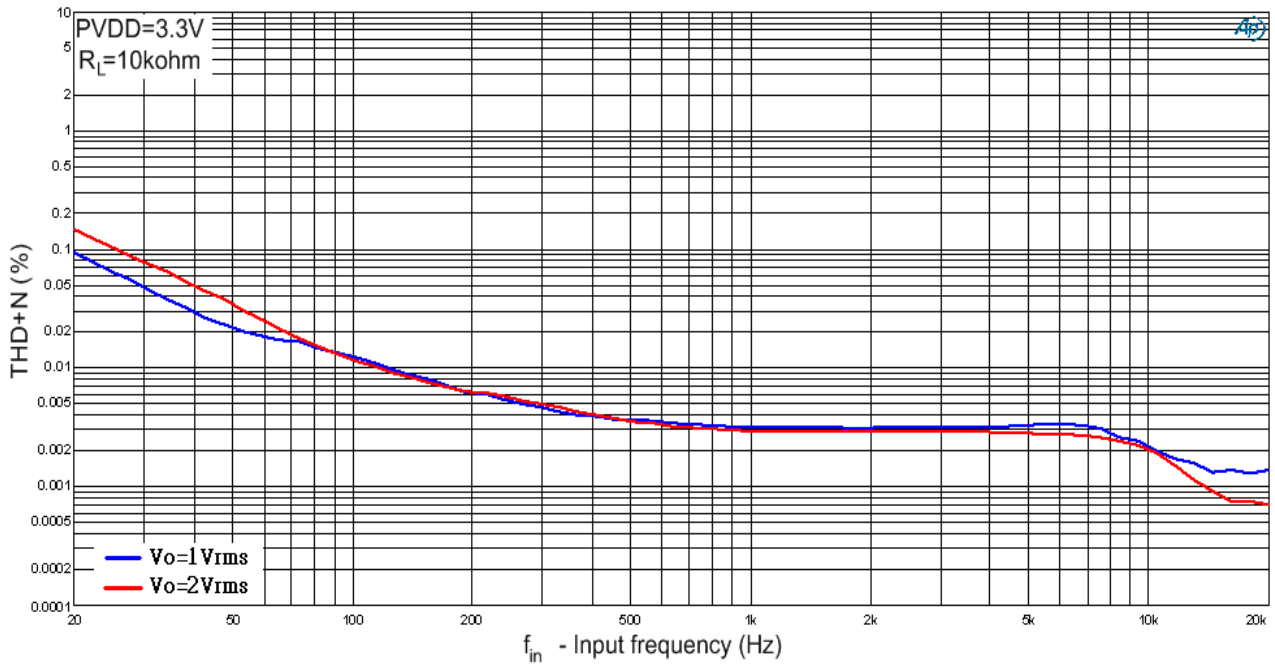

● Crosstalk vs. Signal Frequency

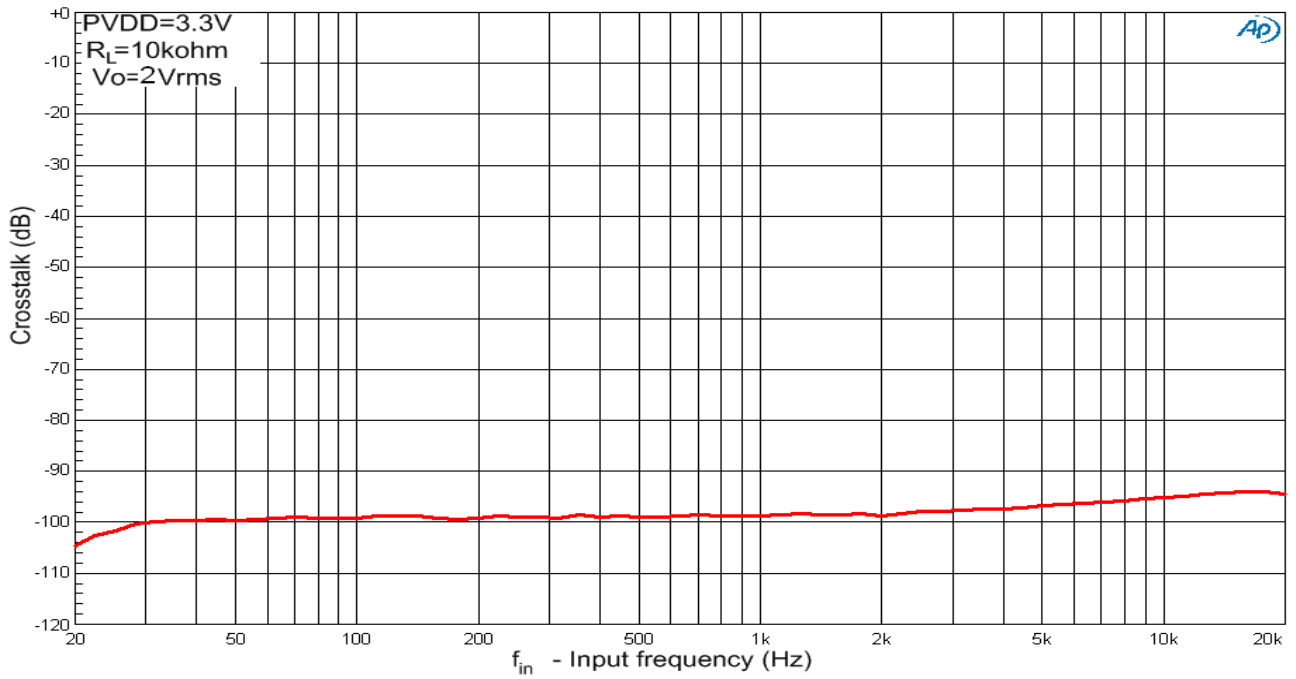

● Gain vs. Signal Frequency

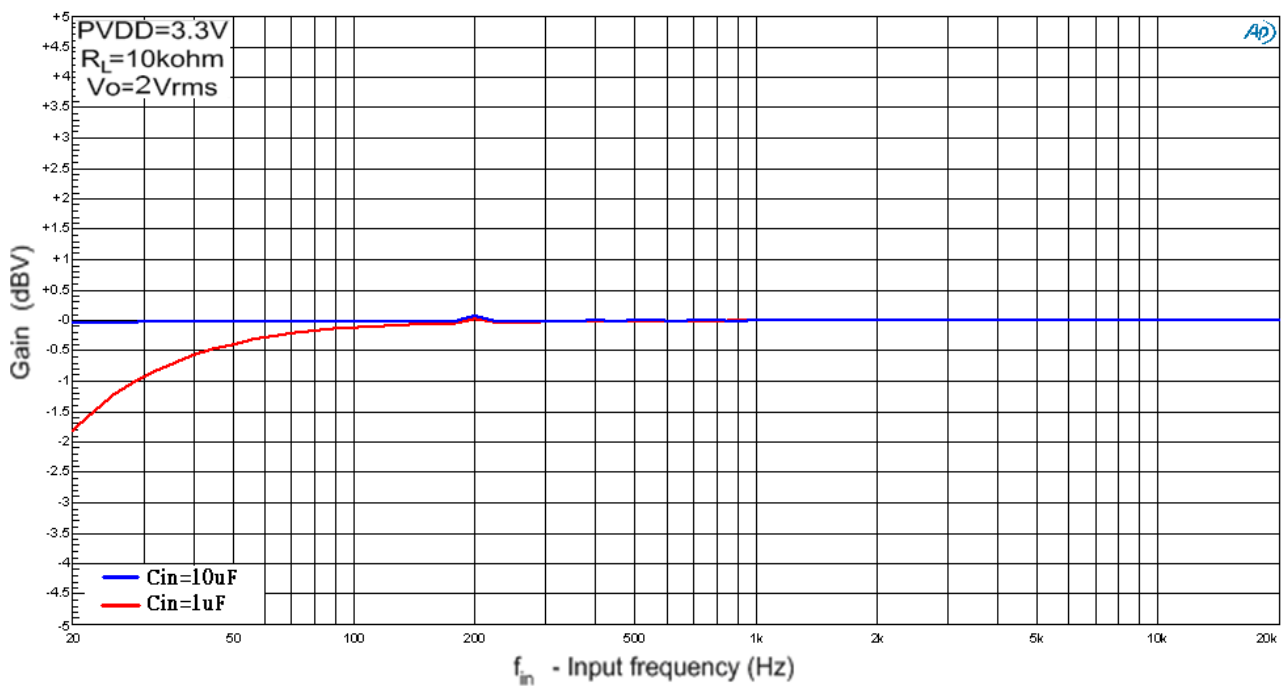

Application Information

■ **Line Driver Amplifiers Operation**

A conventional inverting line-driver amplifier always requires an output dc-blocking capacitor and a bypass capacitor, see Figure 1. DC blocking capacitors are large in size and cost a lot. It also restricts the output low frequency response. POP will occur if the charge and discharge processes on output capacitors are not carefully take cared. Besides, it needs to wait for a long time to charge V_{OUT} from 0V to $V_{DD}/2$.

For a cap-less line driver, see figure 2, a negative supply voltage (-VDD) is produced by the integrated charge-pump, and feeds to line driver's negative supply instead of ground. The positive input can directly connect to ground without a C_{BYPASS} , and V_{OUT} is biased at ground which can eliminate the output dc-blocking capacitors. The output voltage swing is doubled compared to conventional amplifiers.

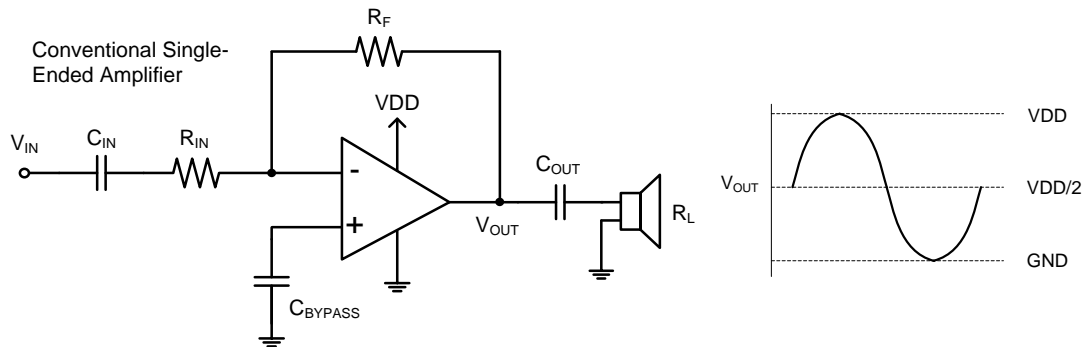

Figure 1. Conventional Line Driver Amplifier

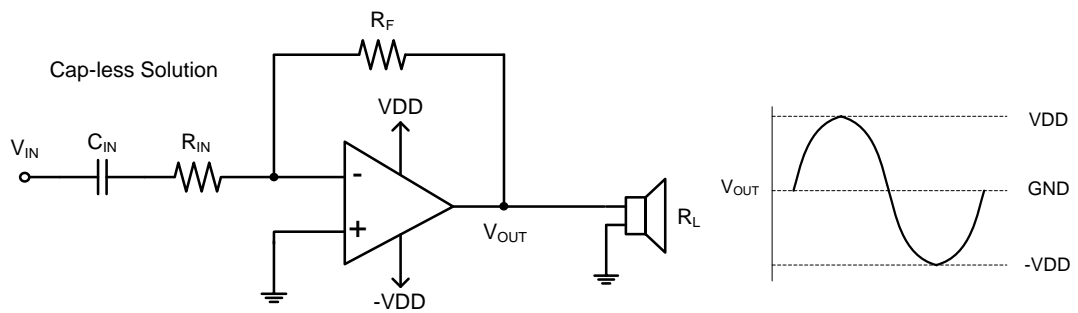

Figure 2. Cap-less Line Driver Amplifier

■ Charge-Pump Operation

The charge-pump is used to generate a negative supply voltage to supply to line-driver. It needs two external capacitors, C_{FLY} and C_{PVSS} , for normal operation, see figure 3 (a). The operation can be analyzed with two phase. In phase I, see figure 3 (b), C_{FLY} is charged to PVDD, and in phase II, see figure 3 (c), the charges on C_{FLY} are shared with C_{PVSS} , that makes PVSS a negative voltage. After an adequate clock cycles, PVSS will be equaled to $-PVDD$. Low ESR capacitors are recommended, and the typical value of C_{FLY} and C_{PVSS} is $1\mu\text{F}$. A smaller capacitance can be used, but the maximum output voltage may be reduced.

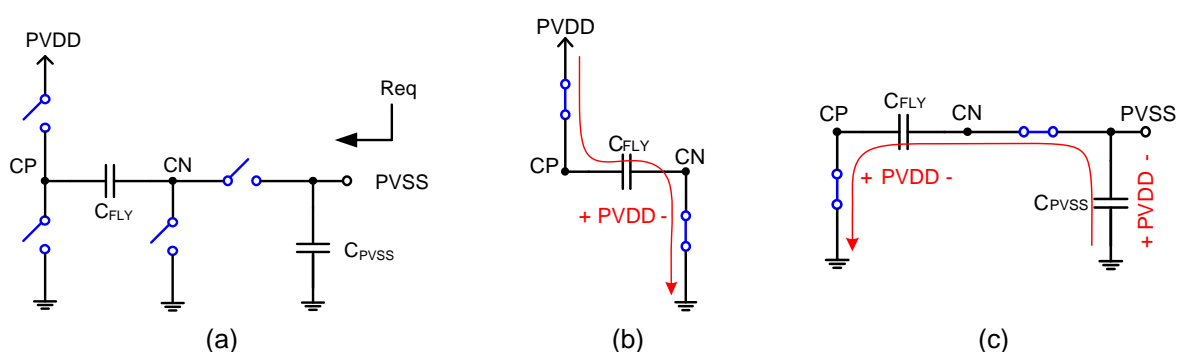

Figure 3. Charge-Pump Operation

■ Enable Function

The enable function is used to reduce power consumption while the device is not in use. When a logic low is applied to this pin, the overall circuits are turned off. Line driver output and PVSS are pulled to ground. When a logic high is applied to enable pin, the PVSS is started to build-up and line driver output signal is released after about 0.5ms typically.

■ Decoupling Capacitors

A low ESR power supply decoupling capacitor is required for better performance. The capacitor should place as close to chip as possible, the value is typically $1\mu\text{F}$. For filtering low frequency noise signals, a $10\mu\text{F}$ or greater capacitor placed near the chip is recommended.

■ Input Blocking Capacitors (C_{IN})

An input blocking capacitor is required to block the dc voltage of the audio source and allows the input to bias at a proper dc level for optimum operation. The input capacitor and input resistor (R_I) form a high-pass filter with the corner frequency determined as following equation:

$$f_c = \frac{1}{2\pi R_I C_{IN}}$$

■ **Gain Setting Resistors (R_I and R_F)**

The line driver's gain is determined by R_I and R_F. The configuration of the amplifier is inverting type, see figure 4. The gain equation is listed as follows:

Inverting configuration: $A_v = -\frac{R_F}{R_I}$

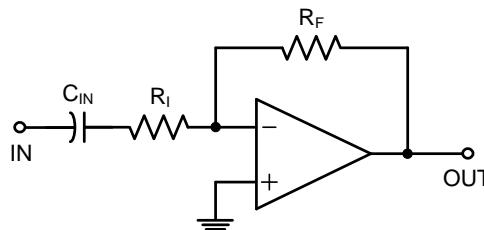

Figure 4. Line Driver Amplifier Configurations

The values of R_I and R_F must be chosen with consideration of stability, frequency response and noise. The recommended value of R_I is in the range from 1kΩ to 47kΩ, and R_F is from 4.7kΩ to 100kΩ for. The gain is in the range from -1V/V to -10V/V for inverting configuration. Table 1 lists the recommended resistor values for different configurations.

R _I (kΩ)	R _F (kΩ)	Inverting Input Gain (V/V)
22	22	-1
15	30	-2
33	68	-2.1
10	100	-10

Table 1. Recommended Resistor Values

■ **Second-Order Filter Configuration**

AD22657B can be used like a standard OPAMP. Several filter topologies can be implemented by using AD22657B, single-ended input configuration, see figure 5. For inverting input configuration, the overall

gain is $-\frac{R2}{R1}$, the high-pass filter's cutoff frequency is $\frac{1}{2\pi R1 C3}$, the low-pass filter's cutoff frequency

is $\frac{1}{2\pi\sqrt{R2 R3 C1 C2}}$, The detail component values are listed on table 2.

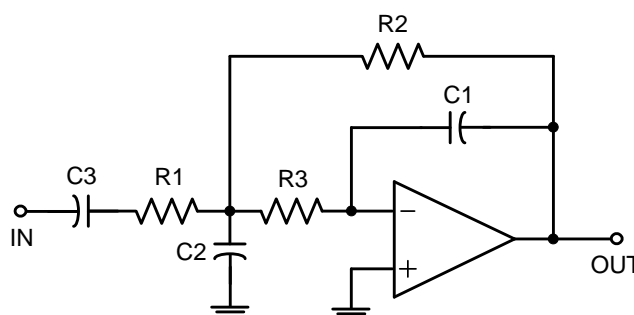

Figure 5. Second-order Active Low-Pass Filter

Gain (V/V)	High Pass (Hz)	Low Pass (kHz)	C1 (pF)	C2 (pF)	C3 (μF)	R1 (kΩ)	R2 (kΩ)	R3 (kΩ)
-1	1.6	40	100	680	10	10	10	24
-1.5	1.3	40	68	680	15	8.2	12	30
-2	1.6	60	33	150	6.8	15	30	47
-2	1.6	30	47	470	6.8	15	30	43
-3.33	1.2	30	33	470	10	13	43	43
-10	1.5	30	22	1000	22	4.7	47	27

Table 2. Second-order Low-Pass Filter Specifications

■ **Over-Temperature Protection**

AD22657B provide an over-temperature protection to limit the junction temperature to 150°C. As junction temperature exceeds 150°C, internal thermal sensor will turn off the drivers immediately. The drivers will turn on again if the junction temperature is smaller than 130°C. A 20°C hysteresis is designed to lower the average junction temperature during continuous thermal overload conditions, increasing lifetime of the chip.

Typical Application Circuit

■ **Line Driver Amplifier**

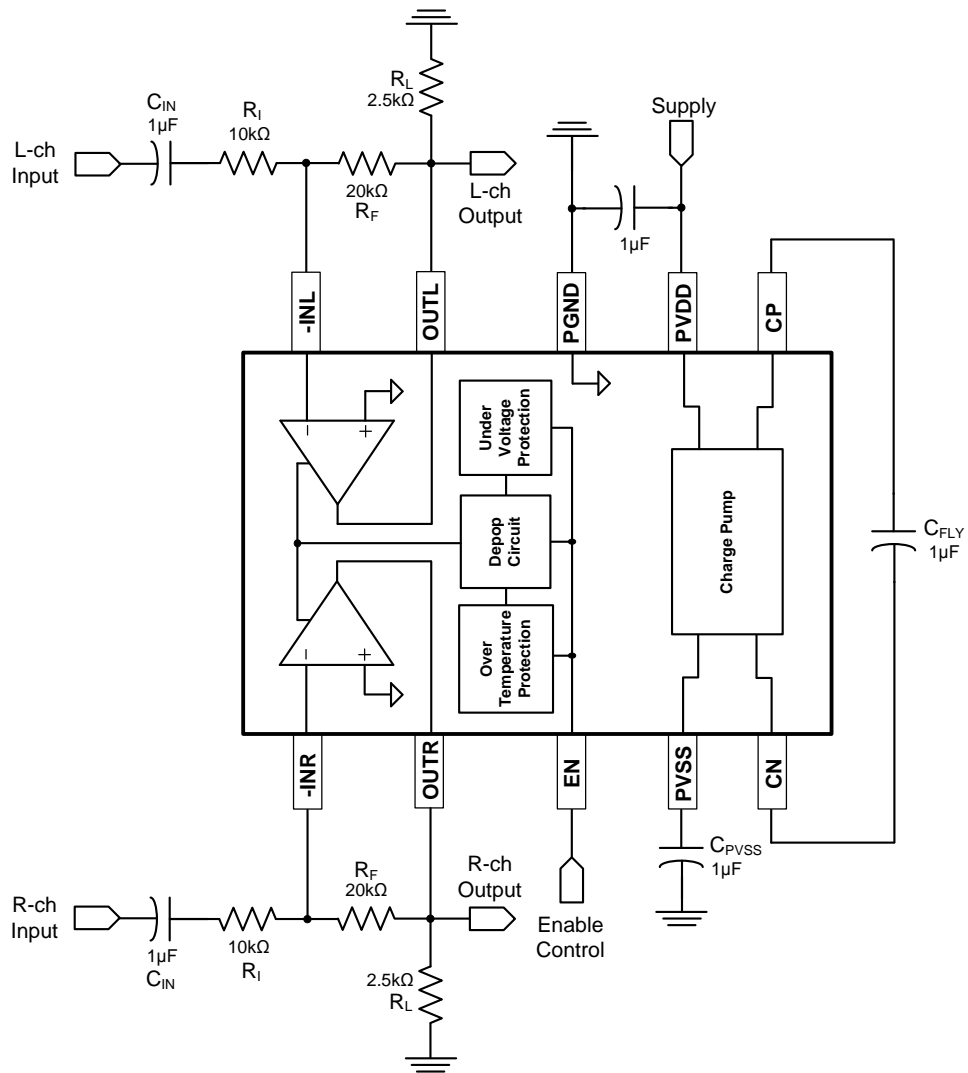

Typical Application Circuit (cont.)

- Second-Order Active Low-Pass Filter (load support $\geq 600\Omega$ only)

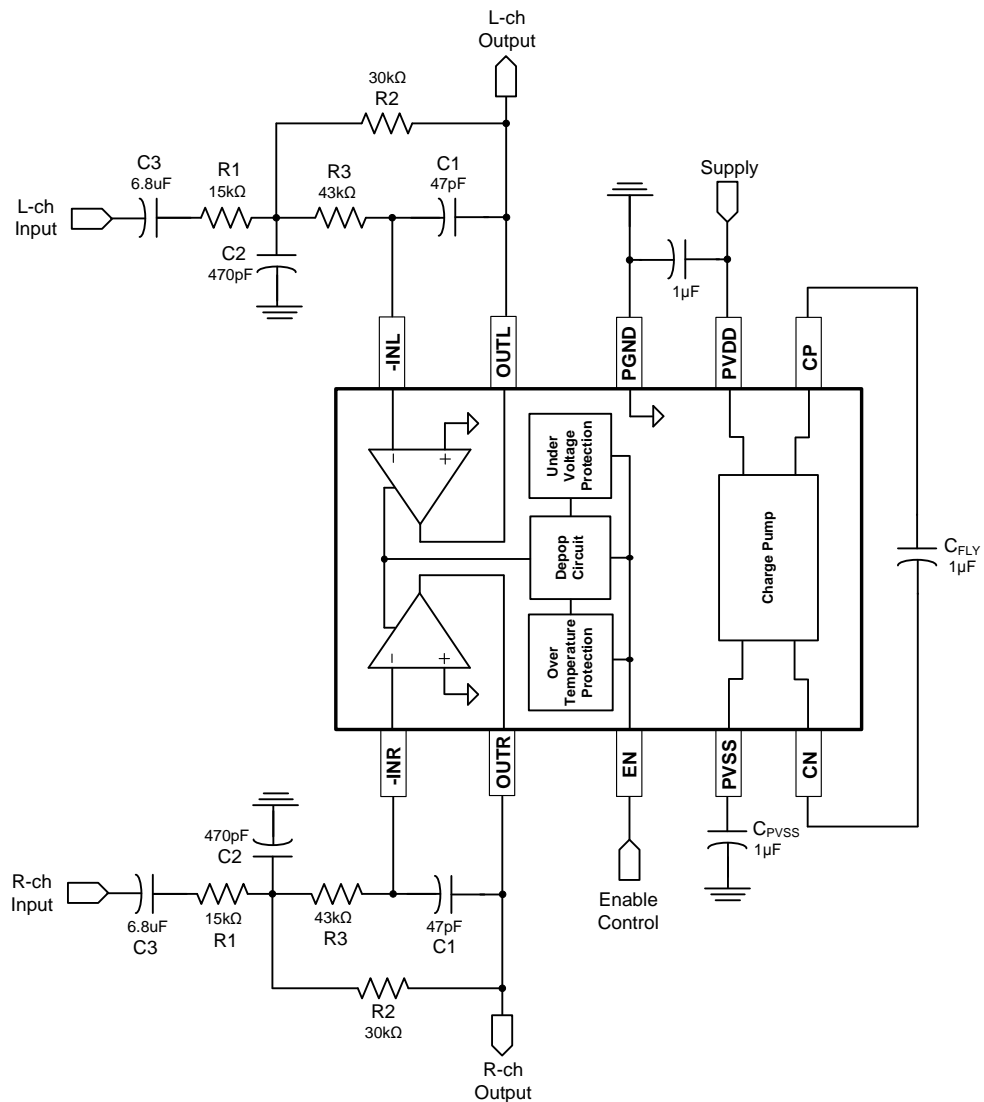

Package Outline Drawing MSOP-10

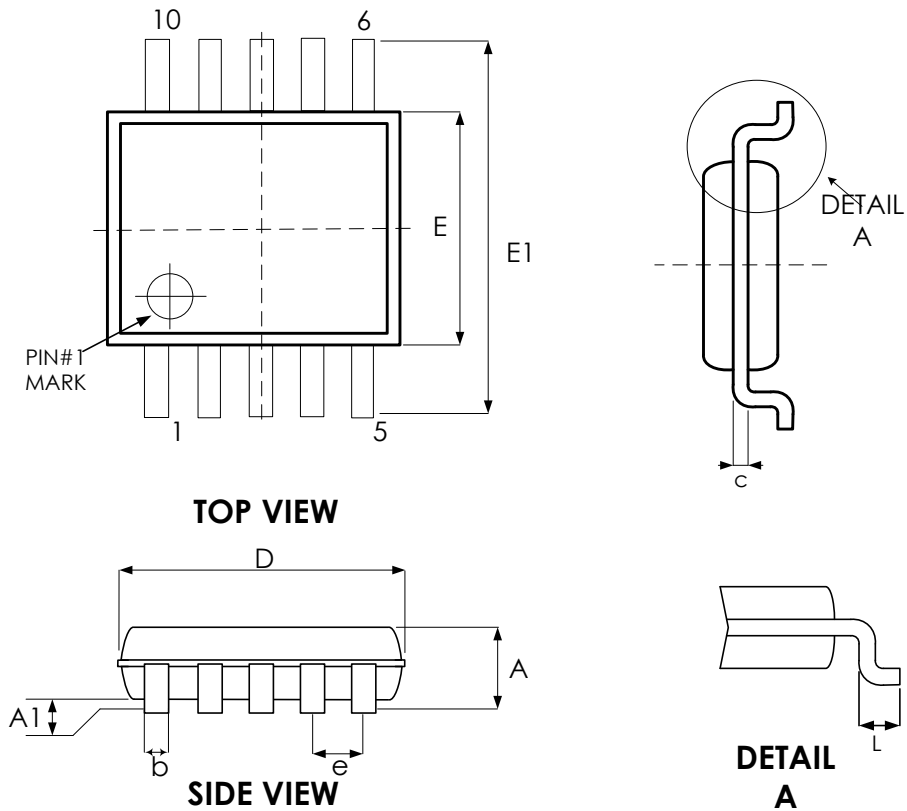

Symbol	Dimension in mm	
	Min	Max
A	0.81	1.10
A1	0.00	0.15
b	0.17	0.33
c	0.08	0.23
D	2.90	3.10
E	2.90	3.10
E1	4.80	5.00
e	0.50 BSC	
L	0.40	0.80

Revision History

Revision	Date	Description
0.1	2014.06.17	Initial version
0.2	2017.12.25	Update typical application circuit.
0.3	2018.04.13	Update Features.

Important Notice

All rights reserved.

No part of this document may be reproduced or duplicated in any form or by any means without the prior permission of ESMT.

The contents contained in this document are believed to be accurate at the time of publication. ESMT assumes no responsibility for any error in this document, and reserves the right to change the products or specification in this document without notice.

The information contained herein is presented only as a guide or examples for the application of our products. No responsibility is assumed by ESMT for any infringement of patents, copyrights, or other intellectual property rights of third parties which may result from its use. No license, either express, implied or otherwise, is granted under any patents, copyrights or other intellectual property rights of ESMT or others.

Any semiconductor devices may have inherently a certain rate of failure. To minimize risks associated with customer's application, adequate design and operating safeguards against injury, damage, or loss from such failure, should be provided by the customer when making application designs.

ESMT's products are not authorized for use in critical applications such as, but not limited to, life support devices or system, where failure or abnormal operation may directly affect human lives or cause physical injury or property damage. If products described here are to be used for such kinds of application, purchaser must do its own quality assurance testing appropriate to such applications.