

FEATURES

- Low Nonlinearity:** $\pm 0.012\%$ max (AD295C)
- Low Gain Drift:** $\pm 60\text{ppm}/^\circ\text{C}$ max
- Floating Input and Output Power:** $\pm 15\text{V dc @ } 5\text{mA}$
- 3-Port Isolation:** $\pm 2500\text{V CMV}$ (Input to Output)
- Complies with NEMA ICS1-111**
- Gain Adjustable:** 1V/V to 1000V/V
- User Configurable Input Amplifier**

APPLICATIONS

- Motor Controls
- Process Signal Isolator
- High Voltage Instrumentation Amplifier
- Multi-Channel Data Acquisition Systems
- Off Ground Signal Measurements

AD295 FUNCTIONAL BLOCK DIAGRAM

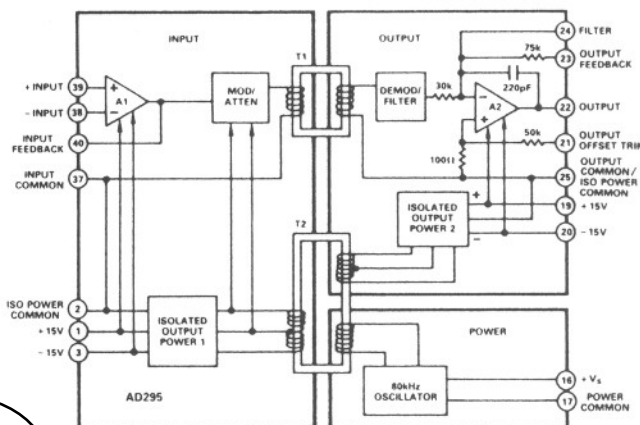

5

GENERAL DESCRIPTION

The AD295 is a high accuracy, high reliability hybrid isolation amplifier designed for industrial, instrumentation and medical applications. Three performance versions are available offering guaranteed nonlinearity error at 10V p-p output: $\pm 0.05\%$ max (AD295A), $\pm 0.025\%$ max (AD295B), $\pm 0.012\%$ max (AD295C). Using a pulse width modulation technique the AD295 provides 3-port isolation between input, output and power supply ports. Using this technique, the AD295 interrupts ground loops and leakage paths and minimizes the effect of high voltage transients. Additionally, floating (isolated) power $\pm 15\text{V dc @ } 5\text{mA}$ is available at both the input and output. The AD295's gain can be programmed at the input, output or both sections allowing for user flexibility. An uncommitted input amplifier allows configuration as a buffer, inverter, subtractor or differential amplifier.

The AD295 is provided in an epoxy sealed ceramic 40-pin package that insures quality performance, high stability and accuracy. Input/output pin spacing complies with NEMA (ICS1-111) separation specifications required for many industrial applications.

WHERE TO USE THE MODEL AD295

Industrial: The AD295 is designed for measuring signals in harsh industrial environments. The AD295 provides high accuracy with complete galvanic isolation and protection from transients or where ground fault currents or high common-mode voltages are present. The AD295 can be applied in process controllers, current loop receivers, motor controls and weighing systems.

Instrumentation: In data acquisition systems the AD295 provides common-mode rejection for conditioning thermocouples, strain gauges or other low-level signals where high performance and system protection is required.

Medical: In biomedical and patient monitoring equipment like diagnostic systems and blood pressure monitors, the AD295 provides protection from lethal ground fault currents. Low level signal recording and monitoring is achieved with the AD295's low input noise ($2\mu\text{V p-p @ } G = 1000\text{V/V}$) and high CMR ($106\text{dB @ } 60\text{Hz}$).

DESIGN FEATURES AND USER BENEFITS

Isolated Power: Isolated power supply sections at the input and output provide $\pm 15\text{V dc @ } 5\text{mA}$. Isolated power is load regulated to 4%. This feature permits the AD295 to excite floating signal conditioners, front-end buffer amplifiers and remote transducers at the input and external circuitry at the output. This eliminates the need for a separate dc/dc converter.

Input Amplifier: The uncommitted input amplifier allows the user to configure the input as a buffer, inverter, subtractor or differential amplifier to meet the application need.

Adjustable Gain: Gain can be selected at the input, output or both. Thus, circuit response can be tailored to the user's application. The AD295 provides the user with flexibility for circuit optimization without requiring external active components.

Three-Port Isolation: Provides true galvanic isolation between input, output and power supply ports. Eliminates the need for power supply and output ports being returned through a common ground.

Wide Operating Temperature: The AD295 is designed to operate over the -40°C to $+100^\circ\text{C}$ temperature range with rated performance over -25°C to $+85^\circ\text{C}$.

Leakage: The low coupling capacitance between input and output yields a ground leakage current of less than $2\mu\text{A rms}$ at 115V ac, 60Hz. The AD295 meets standards established by UL STD 544.

SPECIFICATIONS (typical @ +25°C, & V_S = +15V unless otherwise noted)

MODEL	AD295A	AD295B	AD295C
GAIN			
Range	1V/V to 1000V/V	*	*
Open Loop	100dB	*	*
Accuracy G = 1V/V	± 1.5%	*	*
vs. Temperature (-25°C to +85°C)			
G = 1V/V to 100V/V	± 60ppm/°C max	*	*
Nonlinearity (± 5V Swing) G = 1V-100V/V	± 0.05% max	± 0.025% max	± 0.012% max
INPUT VOLTAGE RATINGS			
Linear Differential Range	± 10V min	*	*
Max Safe Differential Input	± 15V	*	*
Max CMV (Input to Output)			
Continuous ac or dc	± 2500V peak	*	*
ac, 60Hz, 1 Minute Duration	2500V rms	*	*
Max CMV (Input to Power Common/Output to Power Common)			
Continuous ac or dc	± 2000V peak	*	*
ac, 60Hz, 1 Minute Duration	2000V rms	*	*
CMR, Input to Output 60Hz, G = 1V/V			
R _S ≤ 1kΩ Balanced Source Impedance	106dB	*	*
R _S ≤ 1kΩ Source Impedance Imbalance	103dB min	*	*
Max Leakage Current, Input to Output			
@ 115V ac, 60Hz	2μA rms max	*	*
INPUT IMPEDANCE			
Differential	5 × 10 ³ Ω 33pF	*	*
Common Mode	10 ³ Ω 20pF	*	*
INPUT BIAS CURRENT			
Initial, @ +25°C	5nA max	*	*
vs. Temperature (-25°C to +85°C)	± 25pA/°C max	*	*
INPUT DIFFERENCE CURRENT			
Initial, @ +25°C	± 2nA max	*	*
vs. Temperature (-25°C to +85°C)	± 5pA/°C max	*	*
INPUT NOISE (Gain = 1000V/V)			
Voltage			
0.01Hz to 10Hz	2μV p-p	*	*
10Hz to 1kHz	1μV rms	*	*
Current			
0.01Hz to 10Hz	10pA p-p	*	*
FREQUENCY RESPONSE			
Small Signal (-3dB)			
G = 1V/V to 100V/V	4.5kHz	*	*
G = 1000V/V	600Hz	*	*
Full Power, 20V p-p Output			
G = 1V/V to 100V/V	1.4kHz	*	*
G = 1000V/V	200Hz	*	*
Slew Rate G = 1V/V to 100V/V	0.1V/μs	*	*
Settling Time G = 1V/V			
(to ± 0.1% for 10V Step)	550μs	*	*
(to ± 0.1% for 20V Step)	700μs	*	*
OFFSET VOLTAGE, REFERRED TO INPUT			
Initial @ +25°C (Adjustable to Zero)	(± 3 ± 15/G _{IN}) mV max	*	*
vs. Temperature (-25°C to +85°C)	(± 10 ± 450/G _{IN}) μV/°C max	(± 3 ± 300/G _{IN}) μV/°C max	(± 1.5 ± 150/G _{IN}) μV/°C max
vs. Supply	(± 1 ± 200/G _{IN}) μV/%	*	*
RATED OUTPUT			
Voltage, 2kΩ Load	± 10V min	*	*
Output Impedance	2Ω (dc to 100Hz)	*	*
Output Ripple (10Hz to 10kHz)	6mV p-p	*	*
(10Hz to 100kHz)	40mV p-p	*	*
ISOLATED POWER SUPPLIES¹ (V_{ISO1} & V_{ISO2})			
Voltage	± 15V dc	*	*
Accuracy	± 5%	*	*
Current ²	± 5mA max	*	*
Load Regulation (No Load to Full Load)	- 4%	*	*
Ripple, 100kHz BW	12mV p-p	*	*
POWER SUPPLY (+V_S)			
Voltage, Rated Performance	+ 15V dc ± 3%	*	*
Voltage, Operating	+ 12V dc to + 16V dc	*	*
Current, Quiescent (V _S = +15V)	40mA	*	*
With V _{ISO1} Loaded	45mA	*	*
TEMPERATURE RANGE			
Rated Performance	-25°C to +85°C	*	*
Operating	-40°C to +100°C	*	*
Storage	-40°C to +100°C	*	*
CASE DIMENSIONS			
	2.7" × 0.88" × 0.375"	*	*

OUTLINE DIMENSIONS

Dimensions shown in inches and (mm).

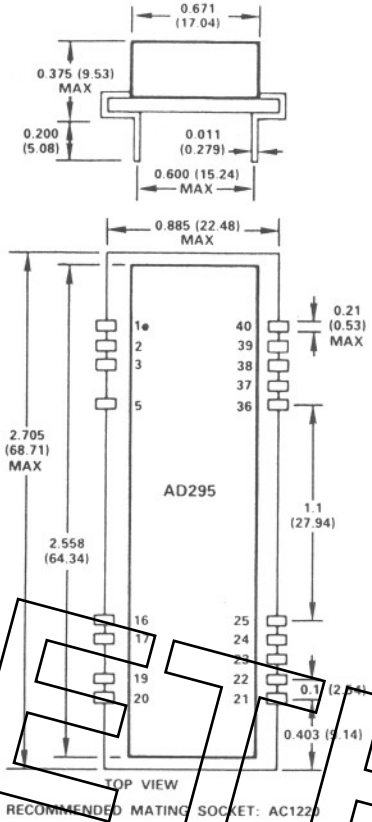

PIN DESIGNATIONS

PIN	FUNCTION	PIN	FUNCTION
1	+15V (+V _{ISO1})	40	INPUT FEEDBACK
2	V _{ISO1} COM	39	+ INPUT
3	-15V (-V _{ISO1})	38	- INPUT
		37	INPUT COM
5	NO CONNECTION	36	NO CONNECTION
16	+V _S	25	OUTPUT COM/ V _{ISO2} COM
17	POWER COMMON	24	FILTER
		23	OUTPUT FEEDBACK
19	+15V (+V _{ISO2})	22	OUTPUT
20	-15V (-V _{ISO2})	21	OUTPUT OFFSET TRIM

NOTES
¹V_{ISO2} accuracy and regulation 10%
²< 10mA can be supplied by V_{ISO1}, if V_{ISO2} is not used.
 *Specifications same as AD295A.
 Specifications subject to change without notice.

Understanding the Isolation Amplifier Performance

INTERCONNECTIONS AND SHIELDING TECHNIQUE

To preserve the high CMR performance of the AD295, care must be taken to keep the capacitance balanced about the input terminals. Use twisted shielded cable for the input signal to reduce inductive and capacitive pick-up. During circuit layout or interassembly connections, twisted wire pairs are recommended for power input and signal output. For basic isolator connections, see Figure 1. Capacitors C1-C5 are required in all applications to achieve the low noise rating and provide adequate filtering of the power supply.

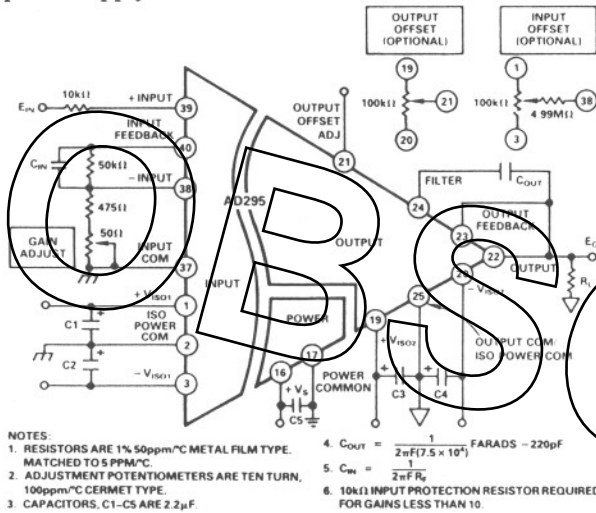

- NOTES:
1. RESISTORS ARE 1% 50ppm/°C METAL FILM TYPE. MATCHED TO 5PPM/°C.
 2. ADJUSTMENT POTENTIOMETERS ARE TEN TURN, 100ppm/°C CERMET TYPE.
 3. CAPACITORS, C1-C5 ARE 2.2μF.
 4. $C_{OUT} = \frac{1}{2\pi(7.5 \times 10^4)} \text{ FARADS} \approx 220\text{pF}$
 5. $C_{IN} = \frac{1}{2\pi F_0}$
 6. 10kΩ INPUT PROTECTION RESISTOR REQUIRED FOR GAINS LESS THAN 10.

Figure 1. Basic Isolator Interconnection

THEORY OF OPERATION

The AD295 obtains its outstanding performance from a pulse width modulation technique using transformer coupling. This technique permits both signal and power transfer from input to the output stage of the isolator. Additionally, this technique provides higher noise immunity and lower nonlinearity than obtained from optically coupled or amplitude modulated transformer coupled techniques.

The three basic sections of the AD295 are shown in Figure 2. The power section 80kHz oscillator signal is transferred to the input and output sections via T2. The signal is then rectified and filtered providing dc power for that section's circuitry and for external application use. The input section consists of input amplifier A1 and the input modulator attenuator circuit. A triangular waveform derived from the 80kHz oscillator is sent to

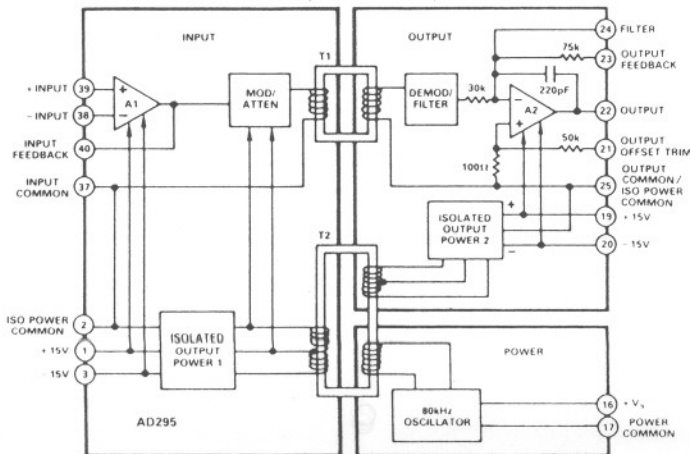

Figure 2. Basic Block Diagram

the modulator. If the input signal of A1 is zero, the triangle wave remains symmetrical. If A1 moves away from zero, the triangle wave moves positive or negative becoming asymmetrical. These modulated signals are converted to a pulsed waveform and transferred to the output section via T1. In the output section the signals are demodulated and filtered. The output amplifier A2 provides gain and additional filtering.

INTERELECTRODE CAPACITANCE AND TERMINAL RATINGS

Capacitance: Interelectrode terminal capacitance arises from stray coupling capacitance effects between the input terminals and signal output terminals. Each are shunted by leakage resistance values exceeding 50GΩ. Figure 3 illustrates the AD295's capacitance between terminals.

Terminal Ratings: CMV performance is given in both continuous ac, or dc peak ratings. Continuous peak ratings apply from dc up to the normal full power response frequency. Figure 3 illustrates the AD295's ratings between terminals. Note that for the ±2500V rating between the input and output terminals to apply, the AD295 must be used in a three port configuration. If the output common is tied to the power common, the input to output CMV rating is ±2000V.

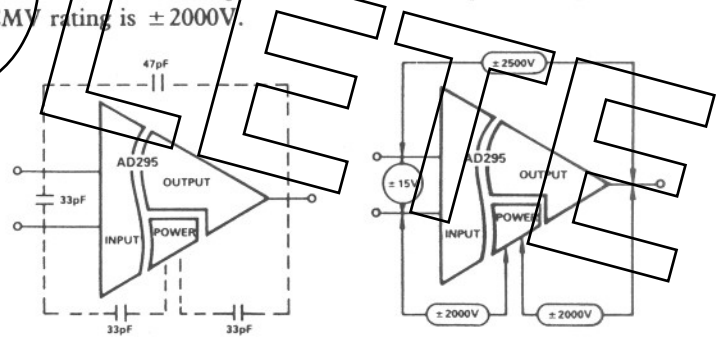

Figure 3. Interelectrode Capacitance and Terminal Ratings

OFFSET AND GAIN ADJUSTMENT PROCEDURE

The calibration procedure, illustrated in Circuits 1 and 2, shows the recommended techniques that can be used to minimize output error. In this example, the output span is -10V to +10V.

Offset Adjustment

1. Configure the AD295 as shown in Circuit 1. $G = 1$.
2. Apply $E_{IN} = 0V$ dc and adjust R_O for $E_O = 0$ volts.
3. Configure the AD295 as shown in Circuit 2. $G = 100$.
4. Apply $E_{IN} = 0V$ dc and adjust R_I for $E_O = 0$ volts.
5. Repeat steps 1-4 if necessary.

Gain Adjust

6. Apply $E_{IN} = +0.1V$ dc adjust R_G for $E_O = +10.000V$ dc.
7. Apply $E_{IN} = -0.1V$ dc and measure the output error (see Curve a.)

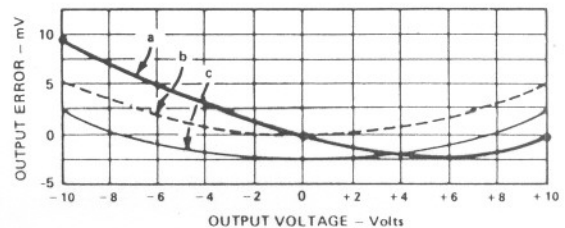

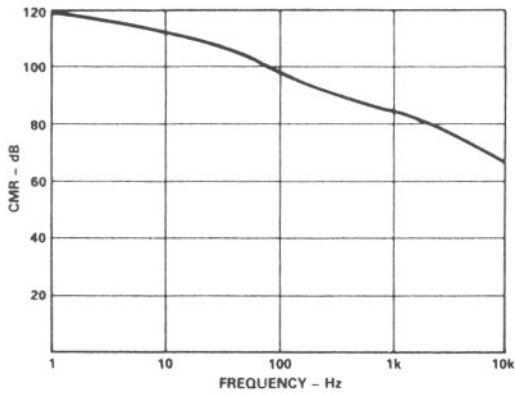

Figure 6. Typical AD295 - CMR vs. Frequency

Input Voltage Noise vs. Bandwidth: Voltage noise referred to the input is dependent on gain and bandwidth. Figure 7 illustrates the typical input noise in μV peak-to-peak in a 10Hz to 10kHz frequency range.

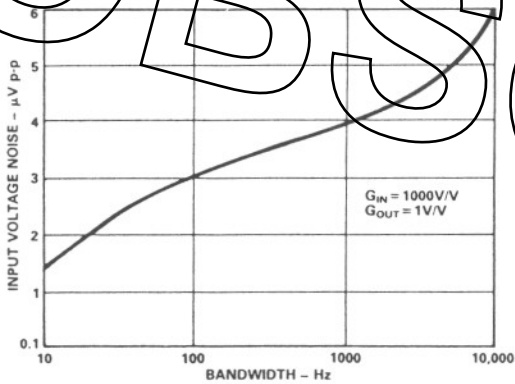

Figure 7. Typical AD295 - Input Voltage Noise vs. Bandwidth

Output Voltage Noise vs. Bandwidth: Voltage noise referred to the output is dependent on gain, bandwidth, input and output noise contributions. Figure 8 illustrates the typical output noise in mV peak-to-peak in a 10Hz to 10kHz frequency range.

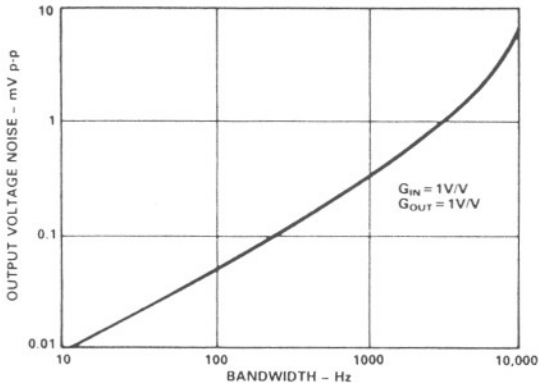

Figure 8. Typical AD295 - Output Voltage Noise vs. Bandwidth

Gain Nonlinearity vs. Output Swing: Linearity error is defined as the deviation of the output voltage from the best straight line and is specified as % peak-to-peak of output voltage span, e.g., nonlinearity of model AD295A operating at an output span of 10V peak-to-peak ($\pm 5\text{V}$) is $\pm 0.05\%$ or $\pm 5\text{mV}$. Figure 9 illustrates the gain nonlinearity for output swing up to $\pm 10\text{V}$ (20V peak-to-peak).

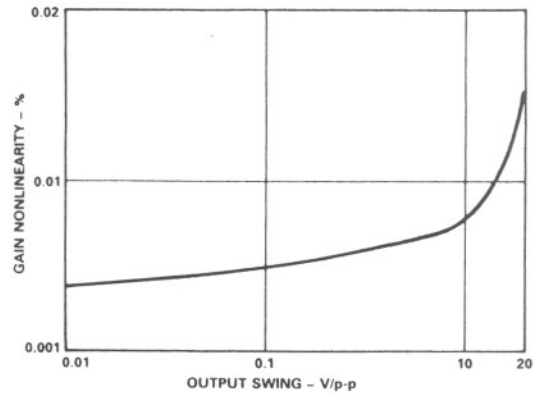

Figure 9. Typical AD295 - Gain Nonlinearity vs. Output Swing

Full Power Bandwidth vs. Gain: Figure 10 illustrates the full power bandwidth vs. gain for the AD295. A 1.4kHz full power response is possible with gain up to 100V/V.

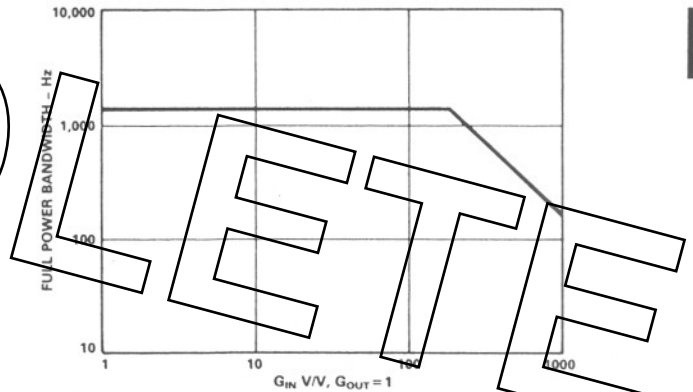

Figure 10. Typical AD295 - Full Power Bandwidth vs. Gain

Small Signal Bandwidth vs. Gain: Figure 11 illustrates the small signal bandwidth vs. gain for the AD295. The small signal response remains at 4.5kHz for gain up to 100V/V.

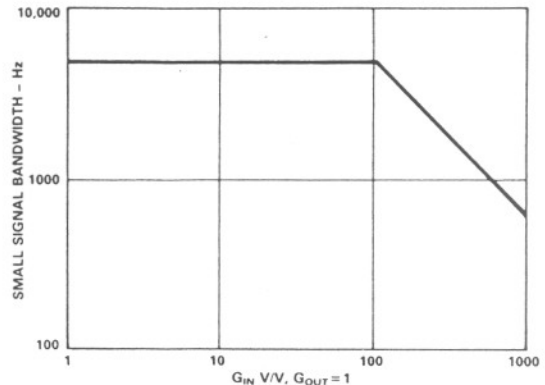

Figure 11. Typical AD295 - Small Signal Bandwidth vs. Gain

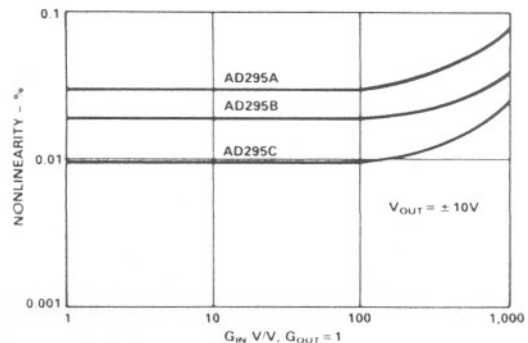
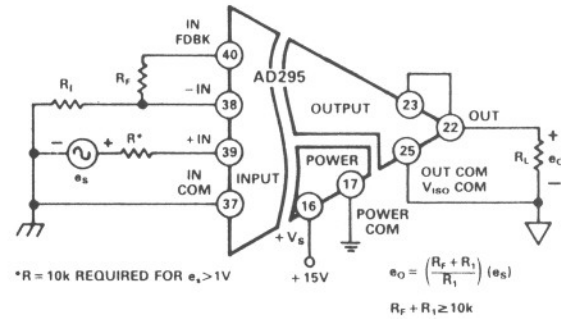
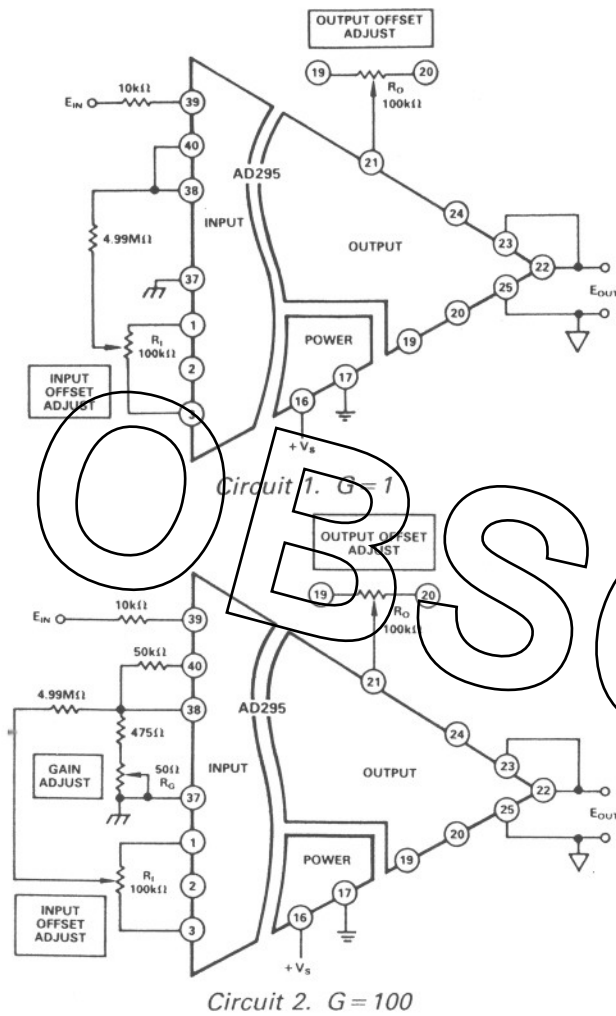

Figure 12. Typical AD295 - Gain Nonlinearity vs. Gain

8. Adjust R_G until the output error is one half that measured in step 6 (see Curve b).
9. Apply $E_{IN} = +0.1V$ dc and adjust R_O until the output error is one half that measured in step 7 (see Curve c).
10. Repeat steps 6-9 if necessary.

Input to output gain greater than unity can be independently set at the input, output, or both. For input gain configuration see Figures 4b and 4c. Output gain configuration is shown in Figure 4d.



b. Basic Gain Noninverting Configuration

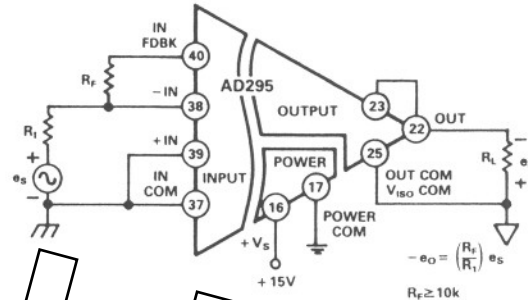

c. Input Gain Inverting Configuration

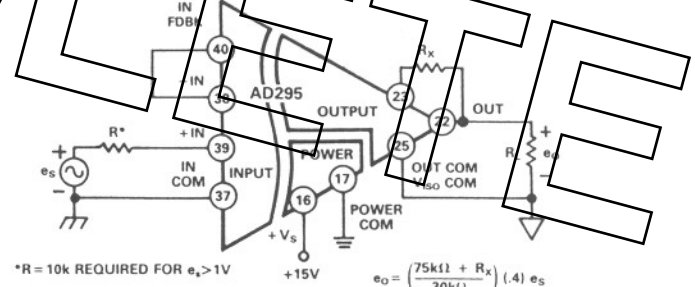

d. Output Gain Noninverting Configuration

Figure 4. Input/Output Gain Configurations

SELECTING GAIN

The AD295 basic gain is unity from input to output. All input signals are attenuated by 2.5 at the input modulator/attenuator then amplified at the output (see Figure 2).

The AD295 contains both input and output amplifiers, the gains of which can be set independently. Figure 4 illustrates the basic gain configurations. Taking input gain helps dilute output stage offset drift and is recommended where offset drift is to be minimized since taking output gain multiplies output drift by the gain taken. Output gain can be used for improved linearity and frequency response at the expense of higher offset drift.

Figure 4a illustrates the basic unity gain configuration. With the uncommitted input amplifier configured as a buffer and pins 22 and 23 of the output amplifier jumpered, $e_o = e_s$.

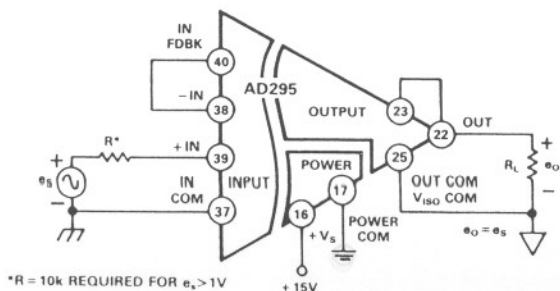

a. Basic Unity Gain Configuration

PERFORMANCE CHARACTERISTICS

Phase Shift vs. Frequency: The phase shift vs. frequency response, for the AD295 is shown in Figure 5.

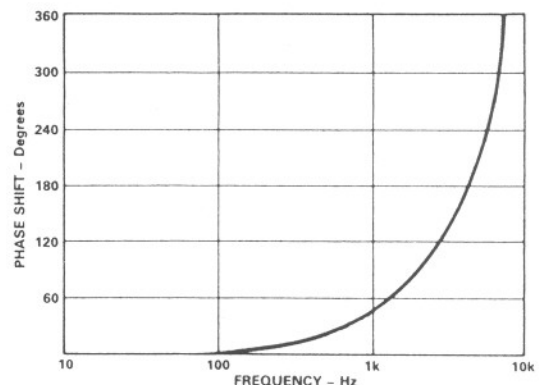

Figure 5. Typical AD295 - Phase Shift vs. Frequency

CMR vs. Frequency: Input-to-output CMR is dependent on source impedance imbalance, input signal frequency and amplifier gain. CMR is rated at 60Hz and 1kΩ source impedance imbalance at a gain of 1V/V. Figure 6 illustrates the CMR vs. frequency for the AD295. CMR approaches 120dB at dc with a source impedance imbalance of 1kΩ.

Isolated Strain Gauge Using Front End of AD295

The AD295 can be used to condition and isolate differential signal sources like those present with strain gauge measurements. Figure 13 illustrates one possible configuration for conditioning a strain gauge. Amplifiers A1 and A2 are powered by the AD295's input isolated power supply. This eliminates the need for a separate dc/dc converter and provides a completely floated differential input. Input gain is selected via R_G and determined by the input gain formula.

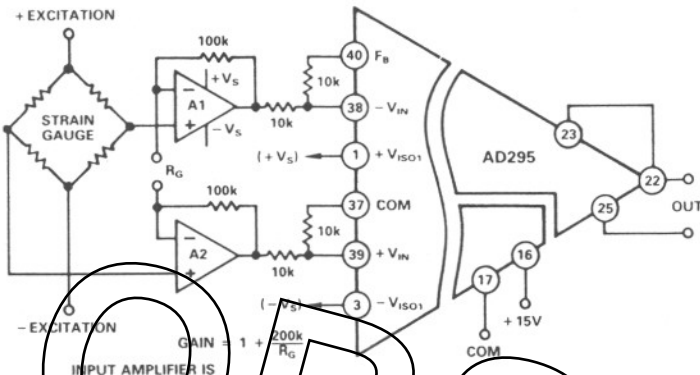

Figure 13. Isolated Strain Gauge Using Front End of AD295

Isolated Temperature Measurement with Cold Junction Compensation

The AD295 can be used to condition, isolate and provide cold junction compensation of thermocouples in temperature measurement applications. With the circuit shown in Figure 14, the AD590 must be thermally connected to the cold junction terminal for an accurate temperature measurement of the terminals. Using this circuit, accurate temperature measurements using the industry's popular J type thermocouple can be made.

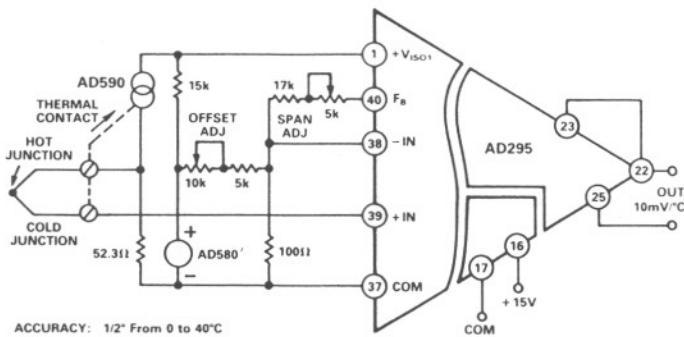

Figure 14. Isolated Temperature Measurement with Cold Junction Compensation

Isolated Voltage-to-Current Loop Converter

Illustrated in Figure 15, the AD295 is used to convert a 0 to +10V input signal to a standard 4-to-20mA current. Here high common-mode rejection and high common-mode voltage suppression are easily obtained with the AD295. The AD295 conditions the 0 to +10V input signal and provides a proportional voltage at the isolator's output. This output signal is converted to a 4-to-20mA current, which in turn is applied to the loop load R_{LOAD} .

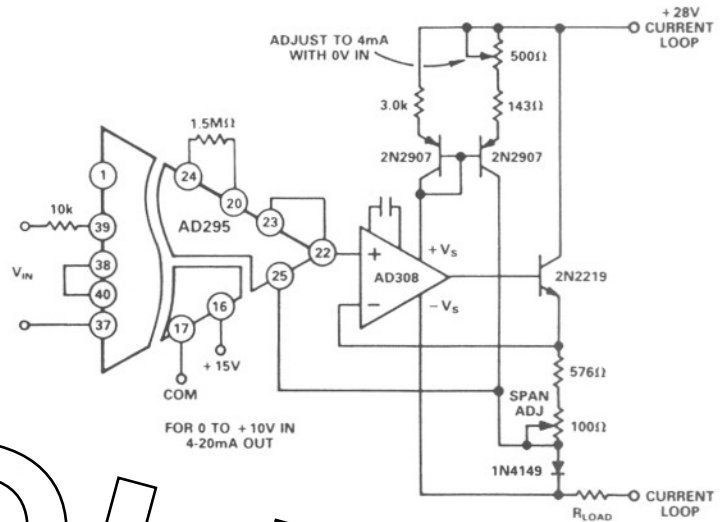

Figure 15. Isolated Voltage-to-Current Loop Converter

Noise Reduction in Data Acquisition Systems

In critical low noise applications like when an isolation amplifier precedes an analog-to-digital converter, it may be desirable to add filtration, otherwise output ripple may cause inaccurate conversions. The 2-pole low-pass active filter shown in Figure 16 limits isolator bandwidth of the AD295. The filter will reduce output ripple and provide smoothing of discontinuous high frequency waveforms.

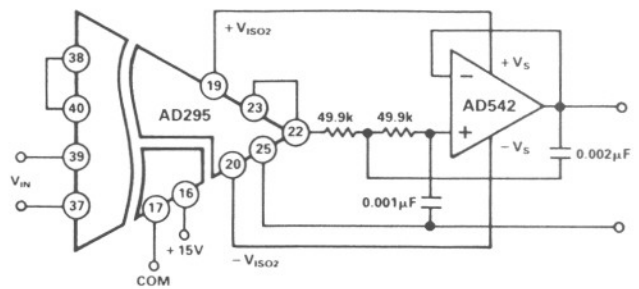

Figure 16. 2-Pole, 2kHz Active Filter