

2A 150kHz 40V Buck DC/DC Converter With Constant Current Loop

General Description

The AD4021 is a 150KHz fixed frequency PWM buck (step-down) DC/DC converter, capable of driving a 2A load with high efficiency, low ripple and excellent line and load regulation. Requiring a minimum number of external components, the regulator is simple to use and include internal frequency compensation and a fixed-frequency oscillator.

The PWM control circuit is able to adjust the duty ratio linearly from 0 to 100%. An enable function, an over current protection function is built inside. An internal compensation block is built in to minimize external component count.

Features

- ◆ Wide 4.5V to 40V Input Voltage Range
- ◆ Output Adjustable from 1.235V to 37V
- ◆ Minimum Drop Out 1.5V
- ◆ Fixed 150kHz Switching Frequency
- ◆ 2A Constant Output Current Capability
- ◆ Internal Optimize Power Transistor
- ◆ Excellent line and load regulation
- ◆ TTL shutdown capability
- ◆ ON/OFF pin with hysteresis function
- ◆ With output constant current loop
- ◆ Built in thermal shutdown function
- ◆ Built in current limit function
- ◆ Built in output over voltage protection
- ◆ SOP8-EP (Exposed PAD) package

Applications

- ◆ Car Charger
- ◆ Battery Charger
- ◆ LED Constant Current Driver

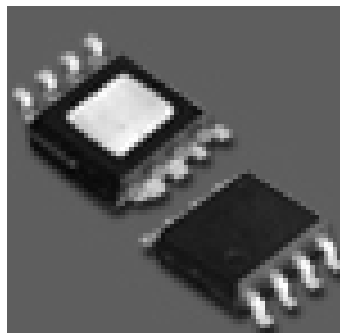

Figure1. Package Type of AD4021

Pin Configurations

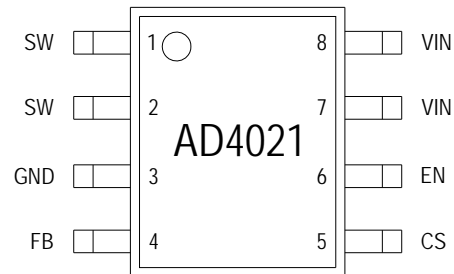

Figure2. Pin Configuration of AD4021 (Top View)

Table 1 Pin Description

Pin Number	Pin Name	Description
1,2	SW	Power Switch Output Pin (SW). Output is the switch node that supplies power to the output.
3	GND	Ground Pin.(Note: Connected the back exposed PAD to Pin3.)
4	FB	Feedback Pin (FB). Through an external resistor divider network, Feedback senses the output voltage and regulates it. The feedback threshold voltage is 1.235V.
5	CS	Output Current Sense Pin; ($I_{load}=0.155V/R_{cs}$)
6	EN	Enable Pin. Drive EN pin low to turn on the device, drive it high to turn it off. Floating is default low.
7,8	VIN	Supply Voltage Input Pin. AD4021 operates from a 4.5V to 40V DC voltage. Bypass Vin to GND with a suitably large capacitor to eliminate noise on the input.

Function Block

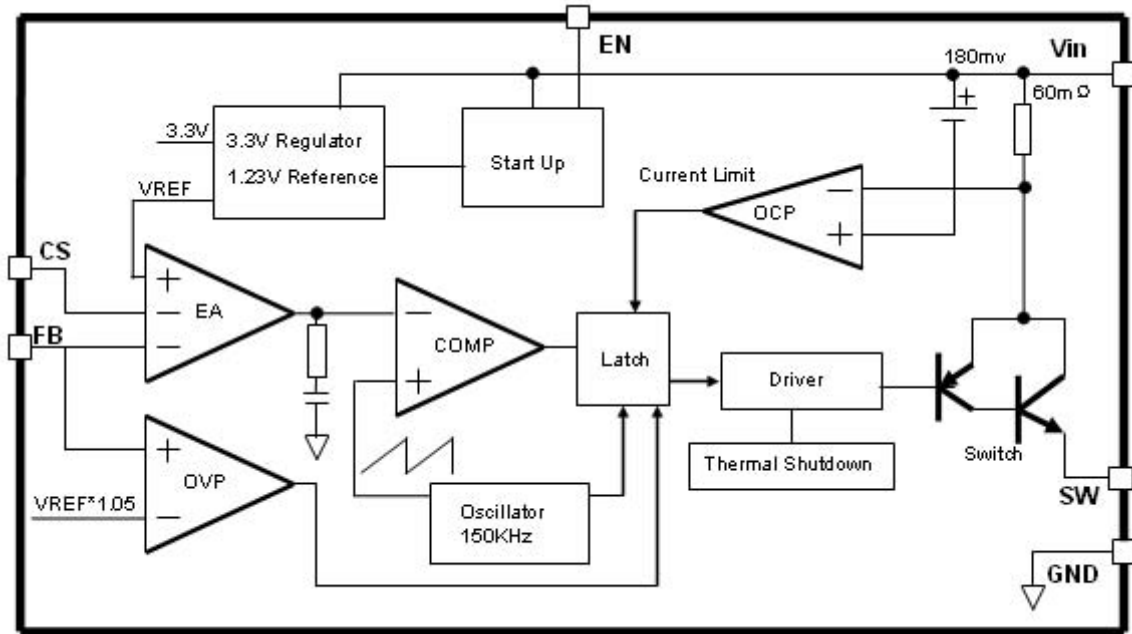

Figure3. Function Block Diagram of AD4021

Typical Application Circuit (Car Charger)

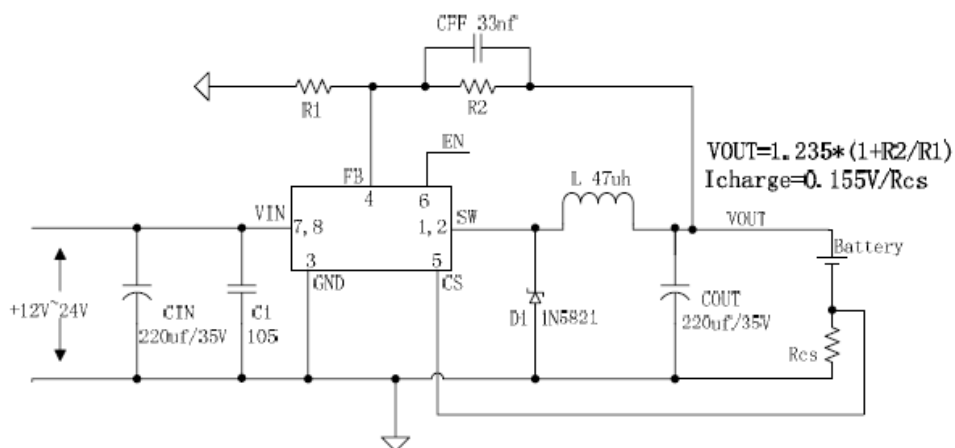

Figure4. AD4021 Typical Application Circuit (Li Battery Charger)

Typical Application Circuit (Buck LED Constant Current Driver)

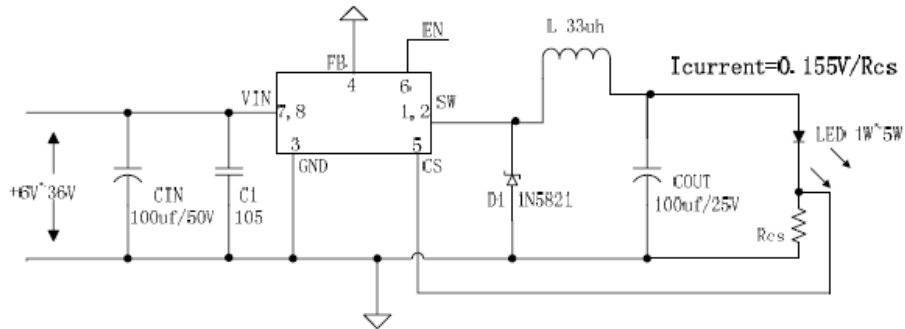

Figure5. AD4021 Typical Application Circuit (LED Constant Current Driver)

Ordering Information

Package	Temperature Range	Part Number	Marking ID	Packing Type
		Lead Free	Lead Free	
		AD4021E1	AD4021E1	Tube
		AD4021TRE1	AD4021E1	Tape & Reel

ADVANCED Pb-free products, as designated with “E1” suffix in the par number, are RoHS compliant.

Absolute Maximum Ratings (Note1)

Parameter	Symbol	Value	Unit
Input Voltage	V _{in}	-0.3 to 45	V
FB Pin Voltage	V _{FB}	-0.3 to V _{in}	V
EN Pin Voltage	V _{EN}	-0.3 to V _{in}	V
SW Pin Voltage	V _{SW}	-0.3 to V _{in}	V
Power Dissipation	P _D	Internally limited	mW
Thermal Resistance (Junction to Ambient, No Heatsink, Free Air)	R _{JA}	50	°C/W
Operating Junction Temperature	T _J	-40 to 125	°C
Storage Temperature	T _{STG}	-65 to 150	°C
Lead Temperature (Soldering, 10 sec)	T _{LEAD}	260	°C
ESD (HBM)		2000	V

Note1: Stresses greater than those listed under Maximum Ratings may cause permanent damage to the device. This is a stress rating only and functional operation of the device at these or any other conditions above those indicated in the operation is not implied. Exposure to absolute maximum rating conditions for extended periods may affect reliability.

AD4021 Electrical Characteristics

T_a = 25°C; unless otherwise specified.

Symbol	Parameter	Test Condition	Min.	Typ.	Max.	Unit
<i>System parameters test circuit figure5</i>						
V _{OUT}	Output Voltage	V _{in} = 4.5V to 40V I _{load} =0.2A to 2A	1.198	1.235	1.272	V
Efficiency	η	V _{in} =12V ,V _{out} =5V I _{out} =2A	-	83	-	%

Electrical Characteristics (DC Parameters)

V_{in} = 12V, GND=0V, V_{in} & GND parallel connect a 220uf/50V capacitor; I_{out}=500mA, T_a=25°C; the others floating unless otherwise specified.

Parameters	Symbol	Test Condition	Min.	Typ.	Max.	Unit
Input operation voltage	V _{in}		4.5		40	V
Shutdown Supply Current	I _{STBY}	V _{EN} =5V		80	200	uA
Quiescent Supply Current	I _q	V _{EN} =0V, V _{FB} =V _{in}		2	5	mA
Oscillator Frequency	F _{osc}		127	150	172	Khz
Switch Current Limit	I _L	V _{FB} =0		3		A
EN Pin Threshold	V _{EN}	High (Regulator OFF) Low (Regulator ON)		1.4 0.8		V
Output Saturation Voltage	V _{CE}	V _{FB} =0V I _{sw} =2A		1.1	1.4	V
Constant current sense Voltage	V _{CS}		0.132	0.15 5	0.178	V

Schottky Diode Selection Table

Current	Surface Mount	Through Hole	VR (The same as system maximum input voltage)				
			20V	30V	40V	50V	60V
1A		√	1N5817	1N5818	1N5819		
3A		√	1N5820	1N5821	1N5822		
		√	MBR320	MBR330	MBR340	MBR350	MBR360
	√		SK32	SK33	SK34	SK35	SK36
	√			30WQ03	30WQ04	30WQ05	
		√		31DQ03	31DQ04	31DQ05	
		√	SR302	SR303	SR304	SR305	SR306

PACKAGE MECHANICAL DATA
SOP8-PP Package Dimension

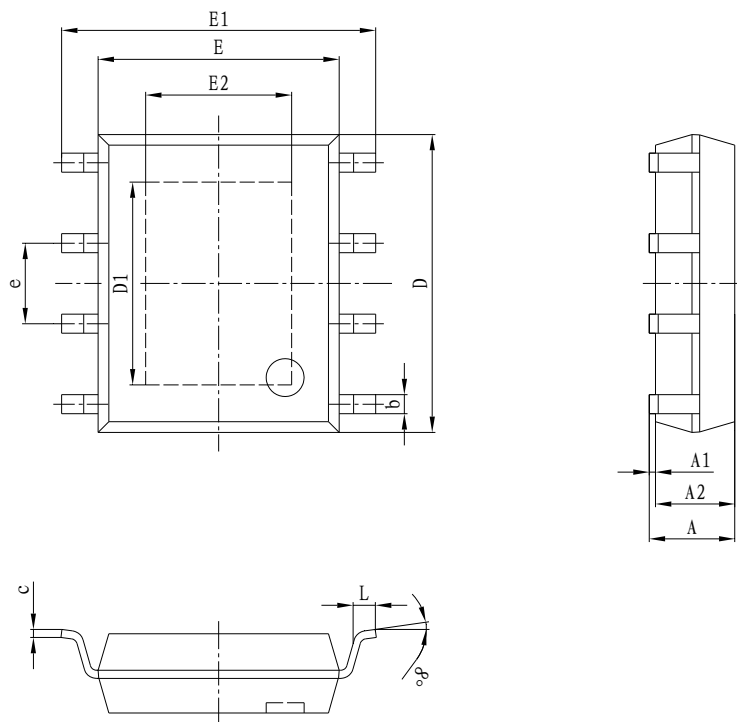

Symbol	Dimensions In Millimeters		Dimensions In Inches	
	Min	Max	Min	Max
A	1.350	1.750	0.053	0.069
A1	0.100	0.250	0.004	0.010
A2	1.350	1.550	0.053	0.061
b	0.330	0.510	0.013	0.020
c	0.170	0.250	0.006	0.010
D1	3.202	3.402	0.126	0.134
D	4.700	5.100	0.185	0.200
E1	5.800	6.200	0.228	0.244
E	3.800	4.000	0.150	0.157
e	1.270TYP		0.050TYP	
E2	2.313	2.513	0.091	0.099
L	0.400	1.270	0.016	0.050