

**3W/CH Stereo Filter-less Class-D Audio Amplifier**

**Features**

- Supply voltage range: 3.0 V to 5.0 V
- 10mA static operation current
- <1uA shutdown current
- 64-step DC volume control from mute to +24dB
- Overload and thermal protection
- Loudspeaker output power @ 10% THD+N
  - 1.75W/CH into 8Ω loudspeaker
  - 3.0W/CH into 4Ω loudspeaker
- High efficiency
  - 91% @ 8Ω, Po,10% THD+N
  - 84% @ 4Ω, Po,10% THD+N

**Description**

The AD52651 is a stereo, filter-less class-D audio amplifier and has a 64-step DC volume controller. Operating with 5.0V loudspeaker driver supply, it can deliver 3.0W/CH output power into 4 Ω loudspeaker within 10% THD+N.

The AD52651 is packaged as SSOP-24L(150mil) is a stereo audio amplifier with high efficiency, which leads to longer battery life, less heat sink requirement, smaller board size and lower system cost, and suitable for the notebook computer, and portable multimedia devices.

**Applications**

- Monitor audio
- Portable multimedia devices
- Mobile phone

**Ordering Information**

Product ID	Package	Packing	Comments
AD52651-ST24NAT	SSOP-24L	56 Units/ Tube 100 Tubes/ Small Box	Green

**Typical Application Circuit**

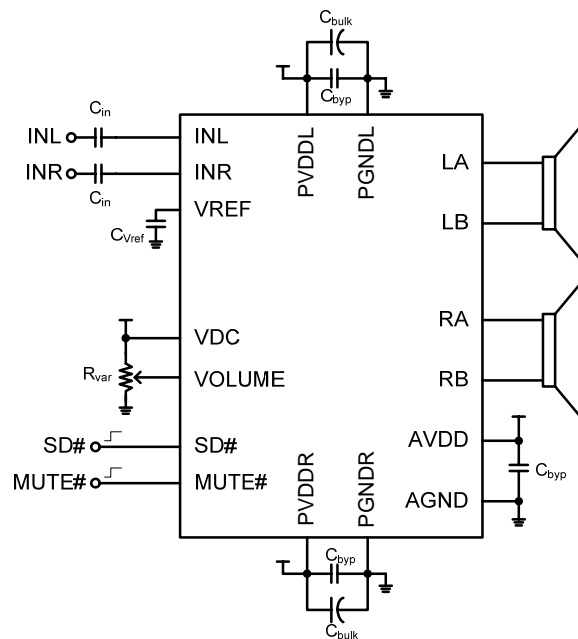

### Pin Assignments

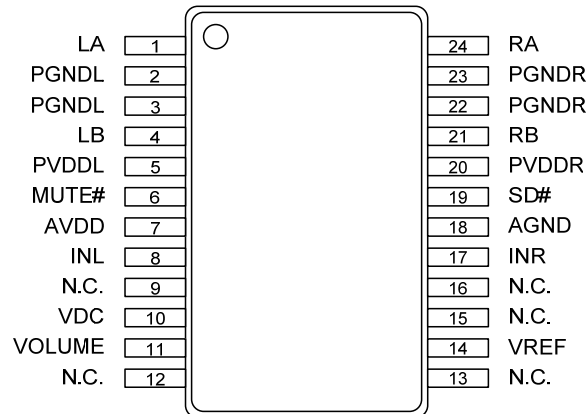

### Pin Description

NAME	TYP	DESCRIPTION	CHARACTERISTIC	
1	LA	O	Speaker driver_Left (+)	
2	PGNDL	G	Power ground_Left	
3	PGNDL	G	Power ground_Left	
4	LB	O	Speaker driver_Left (-)	
5	PVDDL	P	Power supply_Left	
6	MUTE#	I	Mute(low active)	Internal pull-up
7	AVDD	P	Analog power supply	
8	INL	I	Single-ended audio input_Left	
9	N.C.	x	No connection	
10	VDC	I	Full scale level for gain control section	Internal pull-up
11	VOLUME	I	DC voltage for gain setting	Internal pull-up
12	N.C.	x	No connection	
13	N.C.	x	No connection	
14	VREF	I	AVDD/2 reference voltage	
15	N.C.	x	No connection	
16	N.C.	x	No connection	
17	INR	I	Single-ended audio input_Right	
18	AGND	G	Analog power ground	
19	SD#	I	Shutdown(low active)	Internal pull-down
20	PVDDR	P	Power supply_Right	
21	RB	O	Speaker driver_Right (-)	
22	PGNDR	G	Power ground_Right	
23	PGNDR	G	Power ground_Right	
24	RA	O	Speaker driver_Right (+)	

## Functional Block Diagram

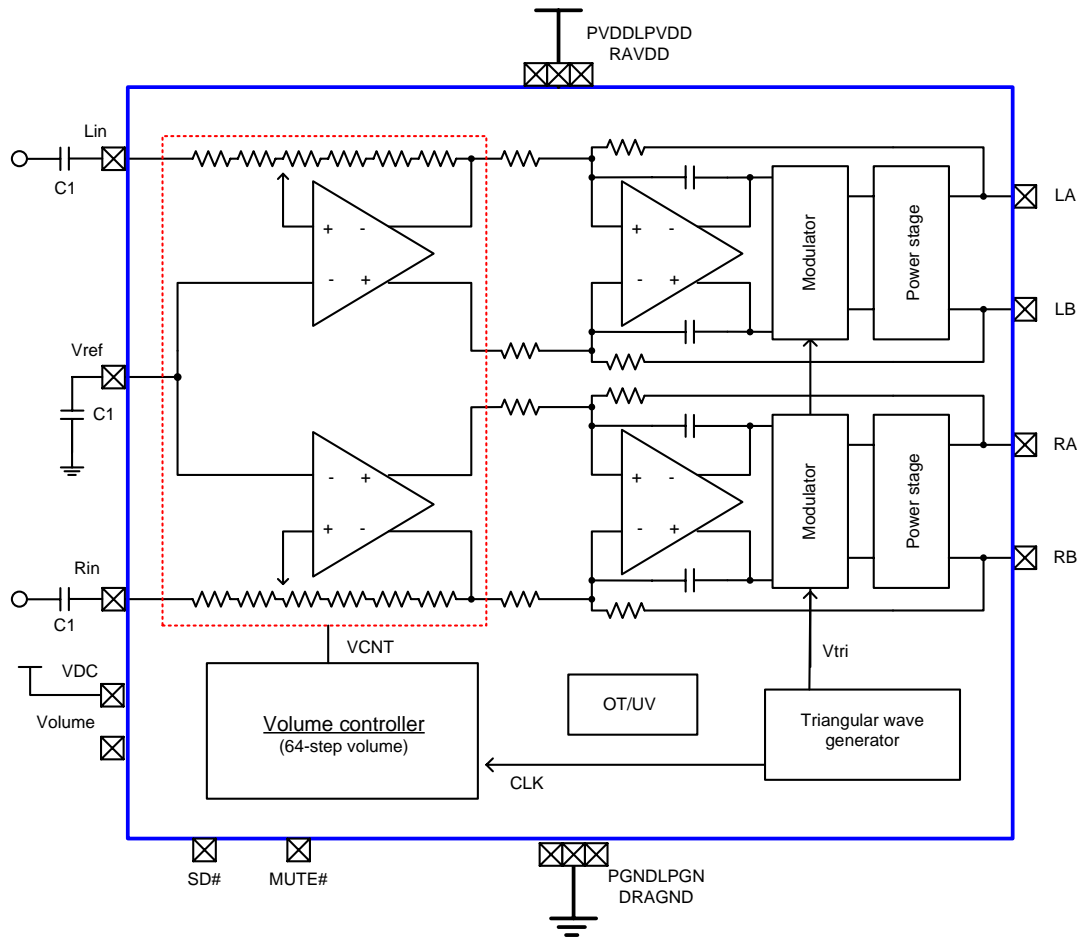

## Available Package

Package Type	Device No.	$\theta_{ja}$ (°C/W)	$\theta_{jc}$ (°C/W)
SSOP-24	AD52651	90	17

Note 1:  $\theta_{ja}$  is measured on a room temperature ( $T_A=25^\circ\text{C}$ ), natural convection environment test board, which is constructed with a thermally efficient, 2-layers PCB. The measurement is tested using the JEDEC51-3 thermal measurement standard.

Note 2:  $\theta_{jc}$  represents the heat resistance for the heat flow between the chip and the package's top surface.

## Marking Information

AD52651

Line 1 : LOGO

Line 2 : Product no.

Line 3 : Tracking Code

Line 4 : Date Code

