

**Class-D Audio Power Amplifier with USB / I<sup>2</sup>S Interface**

**Features**

- Compliant with USB Specification v1.1, and USB 2.0 full speed
- Embedded high efficiency, high performance class D stereo amplifier
- Support I<sup>2</sup>S input and I<sup>2</sup>S output interface of master mode
- Sampling frequencies(Fs) : 48kHz
- +6dB enhancement(Theater function)
- Support both bus-powered and self-powered operation
- Supports Win Me//2000/XP and MacOS
- True plug-and-play application, no driver is required for basic USB speaker application
- Support volume/mute control with external button
- Built-in 5V to 3.3V regulator for internal device operation
- Total efficiency  
80% for 8Ω load @ -1dB 1kHz sine wave input
- Loudspeaker PSNR & DR (A-weighting)  
80dB (PSNR), 78dB (DR) with Bead filter

- 82dB (PSNR), 78dB (DR) with Chock filter
- Anti-pop design
- Over-temperature protection
- Under-voltage shutdown
- Short-circuit detection
- 12 MHz Crystal Input
- 32-pin LQFP(Pb free)

**Description**

AD62550A is a single chip of Class-D audio amplifier with USB/I<sup>2</sup>S interface. When using the power supplied from the USB port, AD62550A can drive a pair of up to 1W speakers due to the built-in, high efficiency and high performance class D amplifiers. The device also has an I<sup>2</sup>S input port and I<sup>2</sup>S output port. The I<sup>2</sup>S input port allows other external audio sources to use the class D amplifier to share the speakers. The I<sup>2</sup>S output port allows other high performance audio device (i.e. AD8356A/AD8256A) to be controlled by AD62550A.

**Functional Block Diagram**

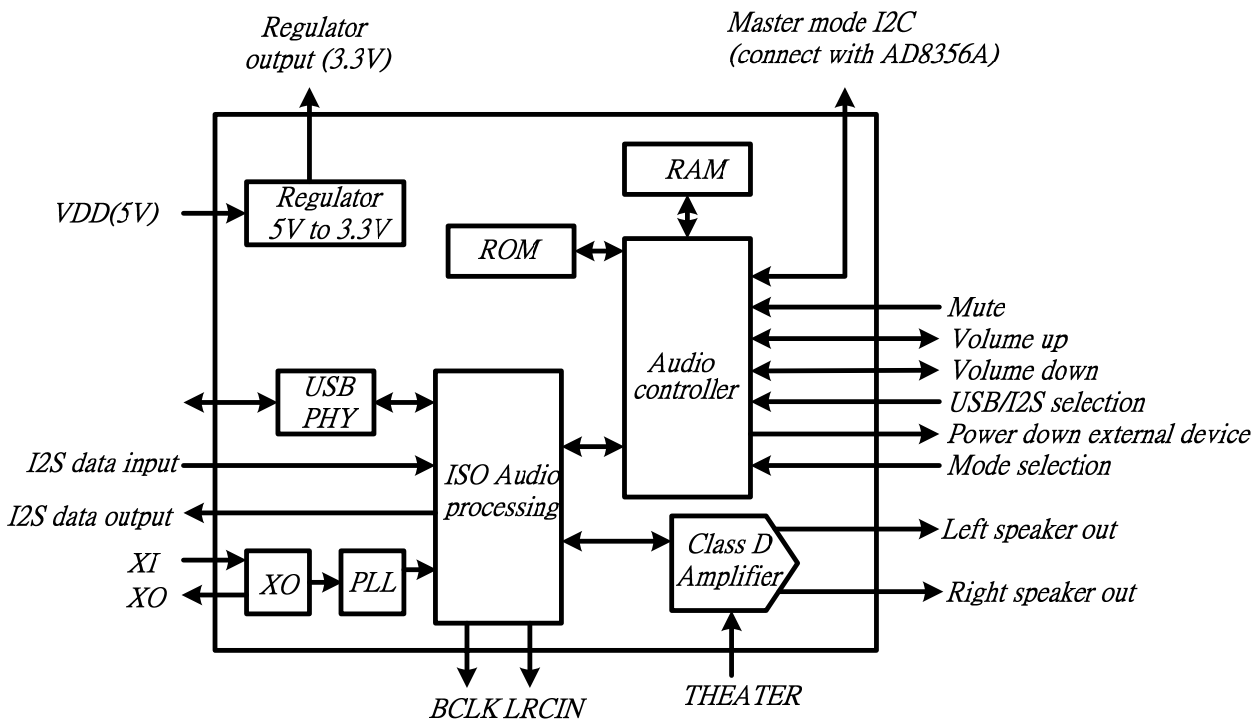

## Pin Assignment

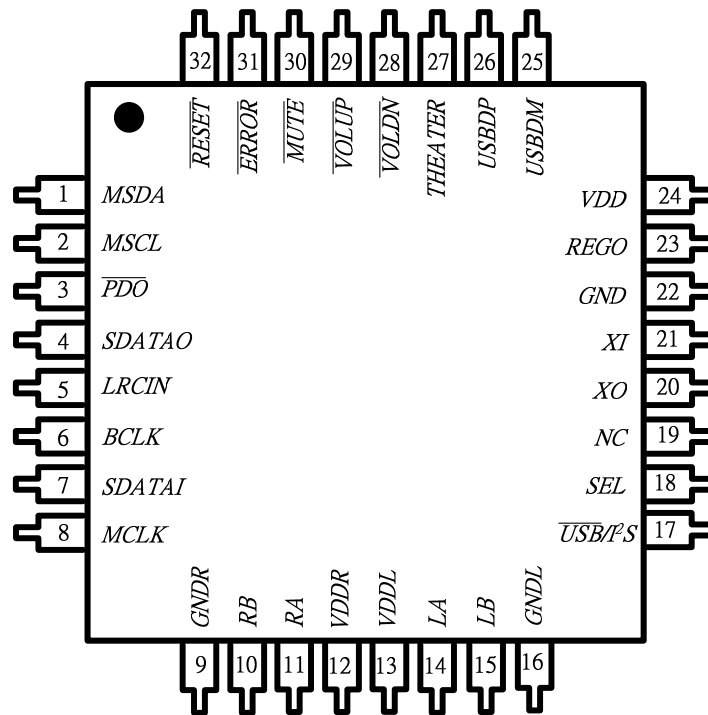

## Pin Description

Pin	Name	Type	Description	Characteristics
1	MSDA	I/O	I <sup>2</sup> C's SDA of Master mode	Schmitt trigger TTL input buffer
2	MSCL	O	I <sup>2</sup> C's SCL of master mode	
3	$\overline{\text{PDO}}$	O	Power-down output ( <b>Note1</b> )	
4	SDA TAO	O	Serial audio output ( <b>Note1</b> )	
5	LRCIN	O	L/R clock output(Fs) ( <b>Note1</b> )	
6	BCLK	O	BCLK output(64xFs) ( <b>Note1</b> )	
7	SDATAI	I	Serial audio data input	Schmitt trigger TTL input buffer
8	MCLK	O	Master clock(256xFs)	
9	GNDR	P	Ground for right channel	
10	RB	O	Right channel output-	
11	RA	O	Right channel output+	
12	VDDR	P	Supply for right channel	
13	VDDL	P	Supply for left channel	
14	LA	O	Left channel output+	
15	LB	O	Left channel output-	
16	GNDL	P	Ground for left channel	

17	USB/I <sup>2</sup> S	I	Low is USB mode, high is I <sup>2</sup> S mode	Schmitt trigger TTL input buffer
18	SEL	I	Mode selection bit	Schmitt trigger TTL input buffer
19	NC	NC	No connection	
20	XO	O	Crystal output	
21	XI	I	Crystal input	
22	GND	P	Ground	
23	REGO	O	3.3V regulator output	
24	VDD	P	5V supply voltage	
25	USBDM	I/O	USB data D-	
26	USBDP	I/O	USB data D+	
27	THEATER	I	Theater mode, high active	Schmitt trigger TTL input buffer
28	VOLDN	I	Volume down, low active	With internal pull-up resistor
29	VOLUP	I	Volume up, low active	With internal pull-up resistor
30	MUTE	I	Power-down and mute of Class D	Schmitt trigger TTL input buffer
31	ERROR	O	Error output	Open-Drain output
32	RESET	I	Reset signal	Schmitt trigger TTL input buffer

**Note1:** Must be strapped resistor 1M $\Omega$  to 3.3V(REGO) or GND. BCLK, LRCIN and PDO must be strapped to GND. SDATAO is s trapped to GND by 1M $\Omega$  when AD62550A's volume/mute is c ontrolled by external button, otherwis e strapped to 3.3V when AD62550A is I<sup>2</sup>C slave mode for SEL1 is logic LOW.

## Absolute Maximum Ratings

Symbol	Parameter	Min	Max	Units
VDD	Supply for regulator input	0	5.5	V
VDDL(R)	Supply for Left (Right) Channel	0	5.5	V
V <sub>i</sub>	Input Voltage	-0.3	3.6	V
T <sub>stg</sub>	Storage Temperature	-65	150	°C
T <sub>a</sub>	Ambient Operating Temperature	0	70	°C
	Voltage Difference between V <sub>DDL</sub> and V <sub>DDR</sub> -1		1	V
	Voltage Difference between V <sub>DDL</sub> (V <sub>DDR</sub> ) and DVDD/AVDD	-3	3	V
	V <sub>DDL</sub> (V <sub>DDR</sub> ) Power-on Voltage Ramp		0.2	V/ $\mu$ s

## Recommended Operating Conditions

Symbol	Parameter	Typ	Units
VDD	Supply for regulator input	4.5~5.5	V
VDDL(R)	Supply for Driver Stage	3.0~5.0	V
T <sub>a</sub> Ambient	Operating Temperature	0~70	°C