

1/4- to 1/12 Duty VFD Controller/Driver

■ Features

- Multiple display modes (16-segment & 12-digit to 24-segment & 4-digit)
- Key scanning (16 x 2 matrix)
- Dimming circuit (eight steps)
- High-voltage output ($V_{EE(max)} = V_{DD} - 35V$)
- 4 channel LED ports
- No external resistors necessary for driver outputs (P-ch open-drain + pull-down resistor output)
- Serial interface (CLK, STB, D_{IN}, D_{OUT})
- Package: 44-pin plastic QFP and LQFP

■ General Description

The AD6315 is a VFD (Vacuum Fluorescent Display or fluorescent Indicator Panel) driver that is driven on a 1/4- to 1/12- duty factor. It consists of 16 segments and 4 grids output lines, 8 segments / grid output driving lines, a display memory, a control circuit, and a key scan circuit. Serial data is input to the AD6315 through a 3-wire serial interface. This VFD driver is ideal as a peripheral device for a single-chip microcomputer.

■ Pin Assignments

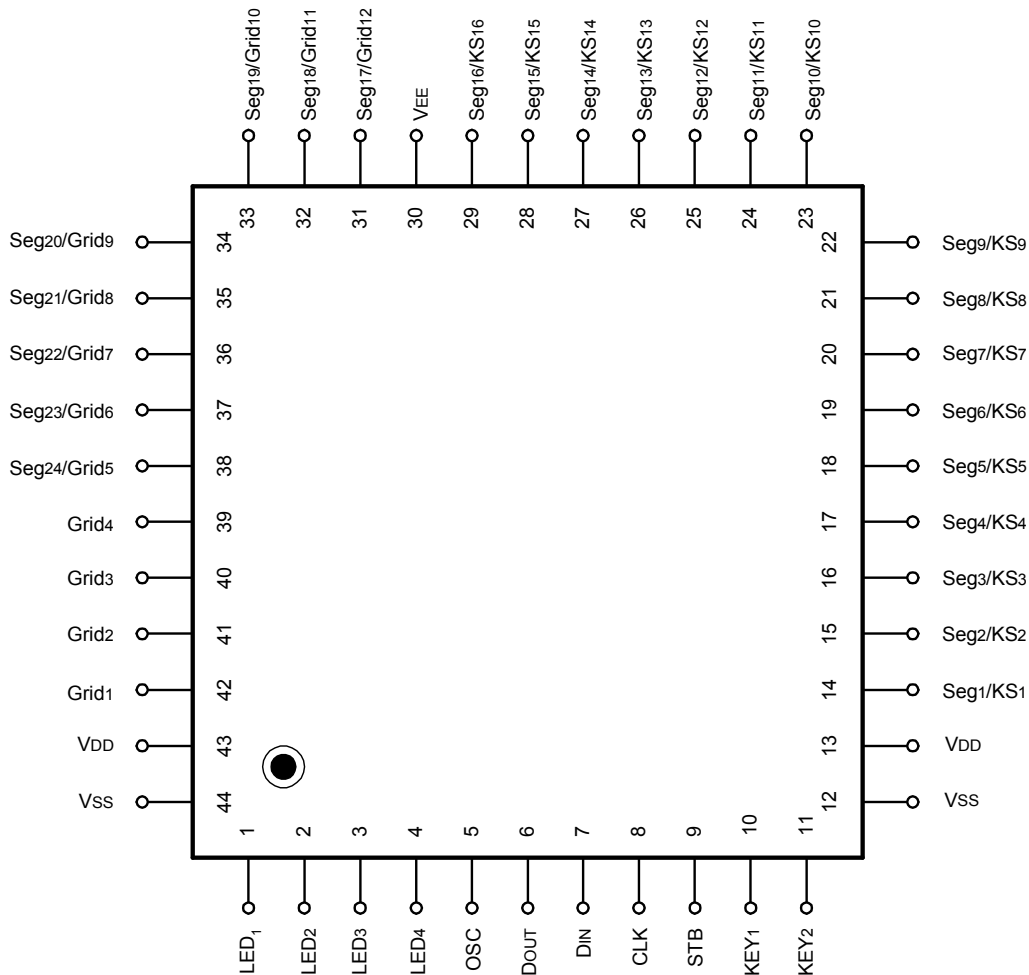

■ Pin Descriptions

Symbol	Name	No.	Description
D _{IN}	Data input	7	Input serial data at rising edge of shift clock, starting from the low order bit.
D _{OUT}	Data output	6	Output serial data at the falling edge of the shift clock, starting from low order bit. This is N-ch open-drain output pin.
STB	Strobe	9	Initializes serial interface at the rising or falling edge of the AD6315. It then waits for reception of a command. Data input after STB falling is processed as a command. While command data is processed, current processing is stopped, and the serial interface is initialized. While STB is high, CLK is ignored.
CLK	Clock input	8	Reads serial data at the rising edge, and outputs data at the falling edge.
OSC	Oscillator pin	5	Connect resistor in between this pin and V _{SS} to set up the oscillation frequency.
Seg ₁ /KS ₁ to Seg ₁₆ /KS ₁₆	High-voltage output (Segment)	14 to 29	Segment output pins (Dual function as key source)
Grid ₁ to Grid ₄	High-voltage output (Grid)	39 to 42	Grid output pins
Seg ₁₇ /Grid ₁₂ to Seg ₂₄ /Grid ₅	High-voltage output (Segment/grid)	31 to 38	These pins are selectable for segment or grid driving.
LED ₁ to LED ₄	LED output	1 to 4	CMOS output
KEY ₁ , KEY ₂	Key data input	10, 11	Data input to these pins is latched at the end of the display cycle.
V _{DD}	Logic power	13, 43	Logic power supply
V _{SS}	Logic ground	12, 44	Connect this pin to system GND.
V _{EE}	Pull-down level	30	Driver power supply

■ Ordering Information

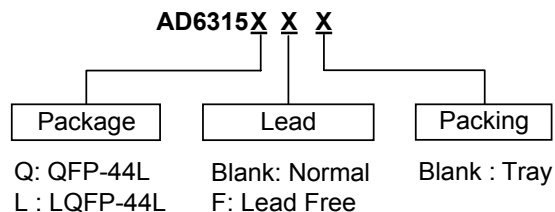

■ Block Diagram

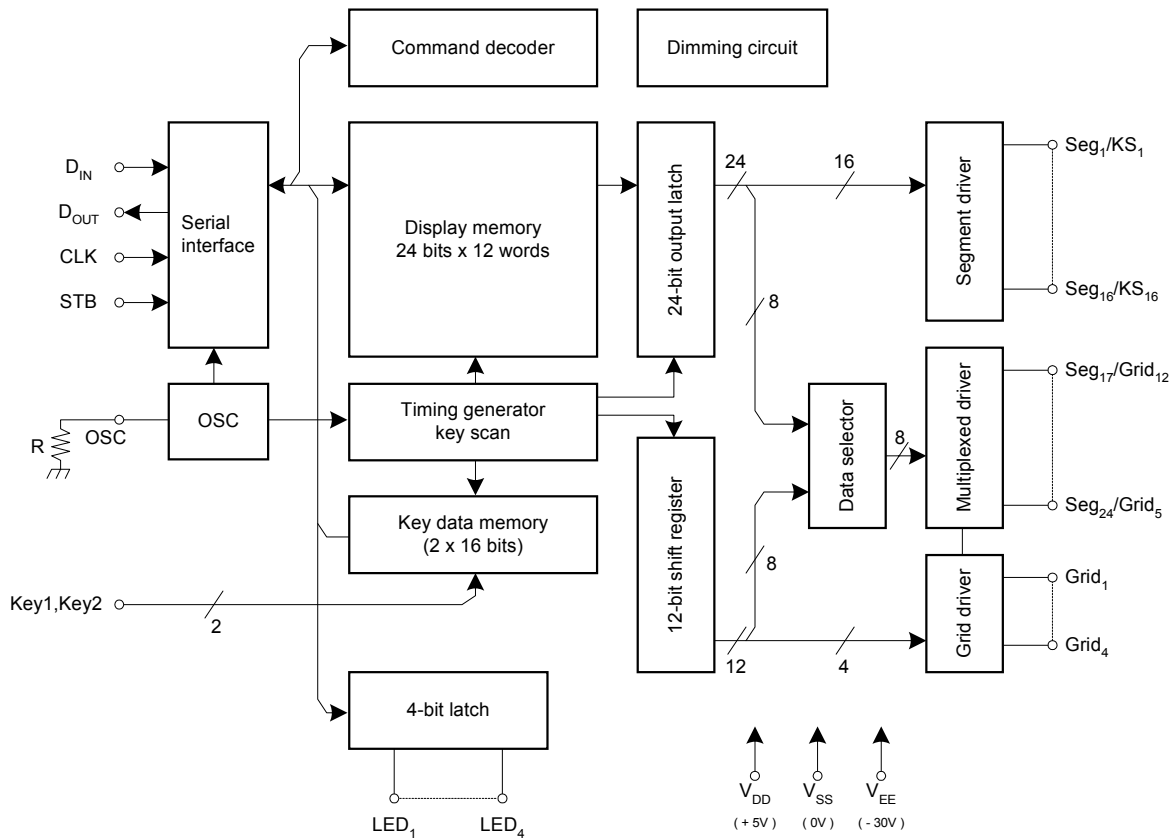

1/4- to 1/12 Duty VFD Controller/Driver
■ Absolute Maximum Ratings ($T_A = 25^\circ\text{C}, V_{SS} = 0\text{V}$)

Parameter	Symbol	Rating	Unit
Logic supply voltage	V_{DD}	-0.5 to +6.0	V
Driver supply voltage	V_{EE}	$V_{DD} + 0.5$ to $V_{DD} - 40$	V
Logic input voltage	V_{I1}	- 0.5 to $V_{DD} + 0.5$	V
VFD driver output voltage	V_{O2}	$V_{EE} - 0.5$ to $V_{DD} + 0.5$	V
LED driver output current	I_{O1}	15	mA
VFD driver output current	I_{O2}	-40 (grid) -15 (segment)	mA
Power dissipation	P_D	800 (Note)	mW
Operating ambient temperature	T_A	-25 to +85	$^\circ\text{C}$
Storage temperature	T_{stg}	-50 to +150	$^\circ\text{C}$

Note : Derate at $-6.4\text{W}/^\circ\text{C}$ at $T_A = 25^\circ\text{C}$ or higher.

Caution : If the absolute maximum rating of even one of the above parameters is exceeded even momentarily, the quality of the product may be degraded. Absolute maximum ratings, therefore, specify the values exceeding which the product may be physically damaged. Be sure to use the product within the range of the absolute maximum ratings.

■ Recommended Operating Range ($T_A = -20$ to $70^\circ\text{C}, V_{SS} = 0\text{V}$)

Parameter	Symbol	Min.	Typ.	Max.	Unit
Logic supply voltage	V_{DD}	4.5	5	5.5	V
High-level input voltage	V_{IH}	$0.7 V_{DD}$		V_{DD}	V
Low-level input voltage	V_{IL}	0		$0.3 V_{DD}$	V
Driver supply voltage	V_{EE}	0		$V_{DD}-35$	V

Remark :

Maximum power consumption

$$P_{max} = \text{VFD driver dissipation} + R_L \text{ dissipation} + \text{LED driver dissipation} + \text{dynamic power consumption}$$

Where

segment current = 3mA, grid current = 15mA, and LED current = 20mA

VFD driver dissipation = number of segments x 6 + number of grids/(number of grids + 1) x 30(mW)

R_L dissipation $\cong (V_{DD} - V_{EE})^2 / 50 \times (\text{number of segments} + 1)$ (mW)

LED driver dissipation = number of LEDs x 20 (mW)

Dynamic power consumption = $V_{DD} \times 5$ (mW)



■ Electrical Characteristics ($T_A = -20$ to $+70^\circ\text{C}$, $V_{DD} = 4.5$ to 5.5V , $V_{SS} = 0\text{V}$, $V_{EE} = V_{DD} - 35\text{V}$)

Parameter	Symbol	Conditions	Min.	Typ.	Max.	Unit
High-level output voltage	V_{OH1}	LED ₁ – LED ₄ , $I_{OH1} = -12\text{ mA}$	$V_{DD} - 1$			V
Low-level output voltage	V_{OL1}	LED ₁ – LED ₄ , $I_{OL1} = +12\text{mA}$			1	V
Low-level output voltage	V_{OL2}	D_{OUT} , $I_{OL2} = 2\text{mA}$			0.4	V
High-level output current	I_{OH21}	$V_O = V_{DD} - 2\text{V}$, Seg ₁ /KS ₁ to Seg ₁₆ /KS ₁₆	-0.3			mA
High-level output current	I_{OH22}	$V_O = V_{DD} - 2\text{V}$, Grid ₁ to Grid ₄ Seg ₁₇ /Grid ₁₂ to Seg ₂₄ /Grid ₅	-15			mA
Driver leakage current	I_{OLEAK}	$V_O = V_{DD} - 35\text{V}$, driver off			-10	μA
Output pull-down resistor	R_L	Driver output	35	45	120	$\text{k}\Omega$
Input current	I_I	$V_I = V_{DD}$ or V_{SS}	- 1		+ 1	μA
High-level input voltage	V_{IH}		$0.7V_{DD}$			V
Low-level input voltage	V_{IL}				$0.3 V_{DD}$	V
Hysteresis voltage	V_H	CLK, D _{IN} , STB		0.35		V
Dynamic current consumption	I_{DDdyn}	Under no load, display off			5	mA

■ Switching Characteristics ($T_A = -20$ to $+70^\circ\text{C}$, $V_{DD} = 4.5$ to 5.5V , $V_{EE} = -30\text{V}$)

Parameter	Symbol	Conditions	Min.	Typ.	Max.	Unit
Oscillation frequency	f_{OSC}	$R = 82\text{ k}\Omega$	350	500	650	kHz
Propagation delay time	t_{PHZ}	CLK → D _{OUT} $C_L = 15\text{pF}$, $R_L = 10\text{ k}\Omega$			300	ns
	t_{PZL}				100	ns
Rise time	t_{TZH1}	$C_L = 300\text{pF}$ Seg ₁ /KS ₁ to Seg ₁₆ /KS ₁₆			2	μS
	t_{TZH2}		Grid ₁ to Grid ₄ , Seg ₁₇ /Grid ₁₂ to Seg ₂₄ /Grid ₅			0.5
Fall time	t_{THZ}	$C_L = 300\text{pF}$, Seg _n , Grid _n			160	μS
Maximum clock frequency	$F_{MAX.}$	Duty=50%			1	MHz
Input capacitance	C_I				15	pF

■ Timing Characteristics ($T_A = -20$ to $+70^\circ\text{C}$, $V_{DD} = 4.5$ to 5.5V)

Parameter	Symbol	Conditions	Min.	Typ.	Max.	Unit
Clock pulse width	PW_{CLK}		400			ns
Strobe pulse width	PW_{STB}		1			μS
Data setup time	T_{setup}		100			ns
Data hold time	t_{HOLD}		100			ns
Clock-strobe time	$t_{CLK-STB}$	CLK \uparrow \rightarrow STB \uparrow	1			μs
Wait time	t_{WAIT}	CLK \uparrow \rightarrow STB \downarrow (Note)	1			μs

Note : Refer to the **Serial communication format**.

■ Function Descriptions

(1) Display RAM Address and Display Mode

The display RAM stores the data transmitted to the AD6315 through the serial communication. The addresses are allocated in 8-bit units.

Seg ₁	Seg ₄	Seg ₈	Seg ₁₂	Seg ₁₆	Seg ₂₀	Seg ₂₄	
00H _L	00H _U	01H _L	01H _U	02H _L	02H _U		DIG ₁
03H _U	03H _U	04H _L	04H _U	05H _L	05H _U		DIG ₂
06H _L	06H _U	07H _L	07H _U	08H _L	08H _U		DIG ₃
09H _L	09H _U	0AH _L	0AH _U	0BH _L	0BH _U		DIG ₄
0CH _L	0CH _U	0DH _L	0DH _U	0EH _L	0EH _U		DIG ₅
0FH _L	0FH _U	10H _L	10H _U	11H _L	11H _U		DIG ₆
12H _L	12H _U	13H _L	13H _U	14H _L	14H _U		DIG ₇
15H _L	15H _U	16H _L	16H _U	17H _L	17H _U		DIG ₈
18H _L	18H _U	19H _L	19H _U	1AH _L	1AH _U		DIG ₉
1BH _L	1BH _U	1CH _L	1CH _U	1DH _L	1DH _U		DIG ₁₀
1EH _L	1EH _U	1FH _L	1FH _U	20H _L	20H _U		DIG ₁₁
21H _L	21H _U	22H _L	22H _U	23H _L	23H _U		DIG ₁₂

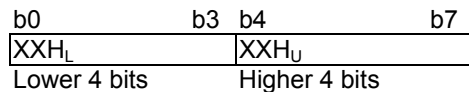

1/4- to 1/12 Duty VFD Controller/Driver

(2) Key Matrix and Key-input Data Storage RAM

The key matrix is made up of a 16 X 2 matrix, as shown below.

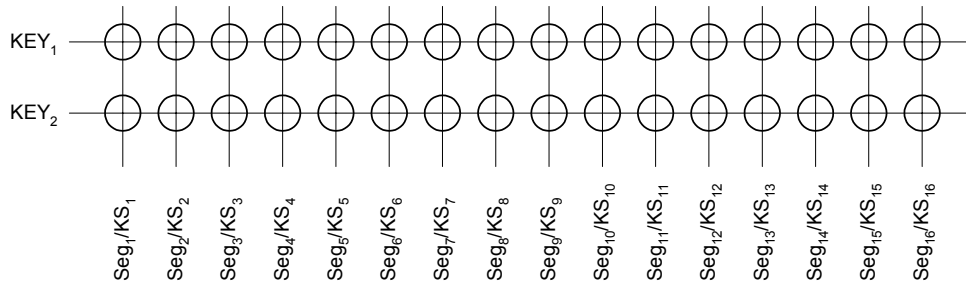

The data of each key is stored as follows, and is read with the read command starting from the least significant bit.

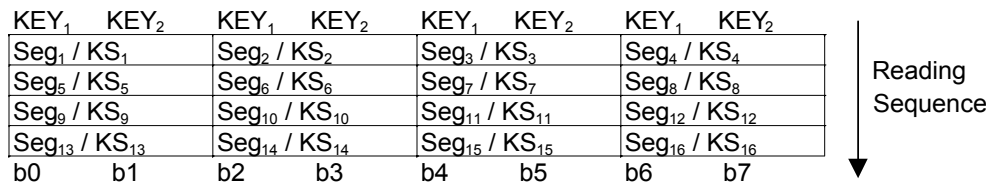

(3) LED Port

Data is written to the LED port with the write command, starting from the least significant bit. "L" output when the bit of this port is 0, and "H" output when the bit is 1. The data of bits after the 5th bit are ignored.

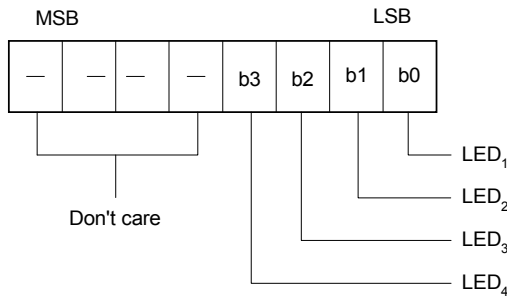

Note: On power application, all the LED ports are "L" output.

(4) Commands

Commands set the display mode and status of the VFD driver.

The first 1 byte input to the AD6315 through the DIN pin after the STB pin has fallen is regarded as a command. If STB is set high while commands/data are transmitted, serial communication is initialized, and the commands/data being transmitted are invalid (however, the commands/data previously transmitted remain valid).

1/4- to 1/12 Duty VFD Controller/Driver

(I) Display mode setting commands

These commands initialize the AD6315 and select the number of segments and the number of grids (1/4- to 1/12- duty, 16 segments to 24 segments).

When these commands are executed, the display is forcibly turned off, and key scanning is also stopped. To resume display, the display command "ON" must be executed. If the same mode is selected, however, nothing happens.

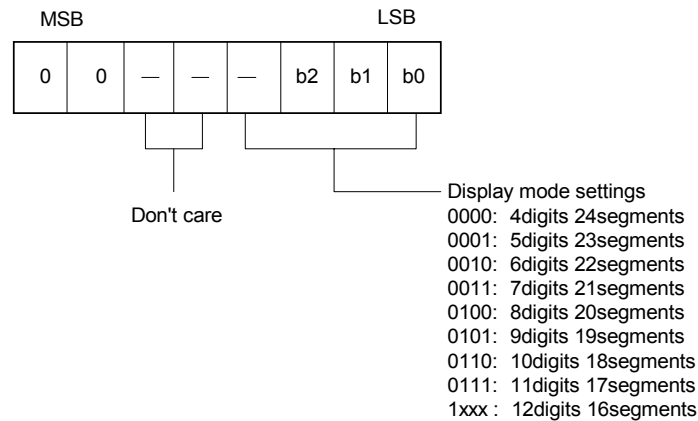

Note: On power application, the 12-digit, 16-segment mode is selected.

(II) Data setting commands

These commands set data write and data read modes.

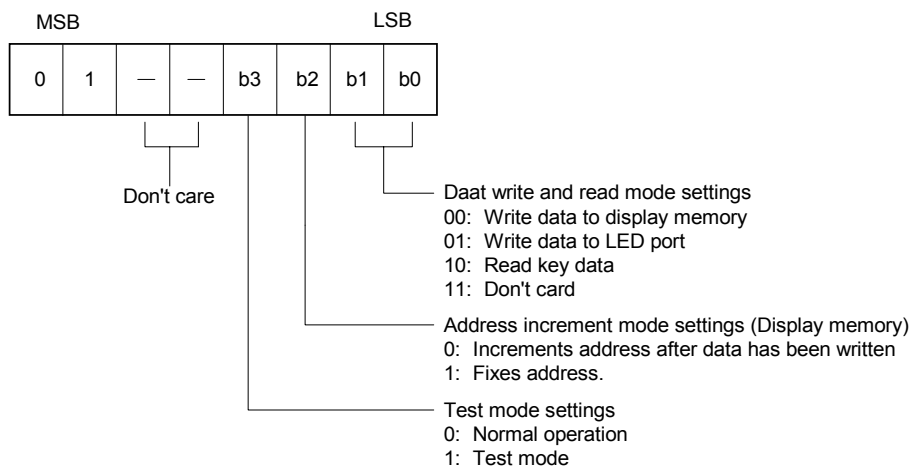

Note: For power application, the normal operation and address increment modes are set.

1/4- to 1/12 Duty VFD Controller/Driver

(III) Address setting command

These commands set an address of the display memory.

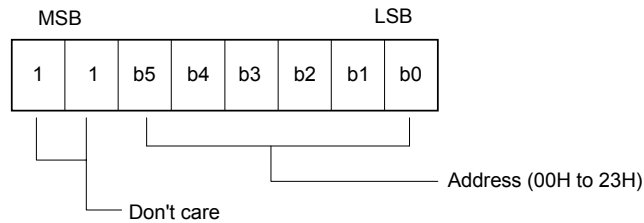

Note : (a) If address 24H or higher is set, data is ignored, until a valid address is set.
 (b) On power application, the address is set to 00H.

(IV) Display control commands

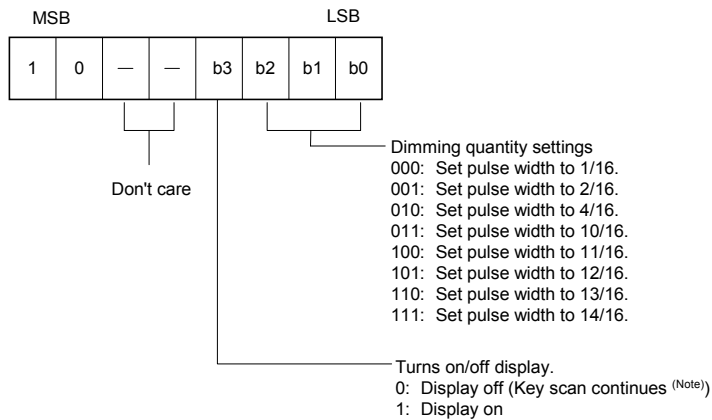

Note : (a) On power application, key scanning is stopped.
 (b) 1/16 pulse width is set and the display is turned off.

(5) Key Scanning And Display Timing

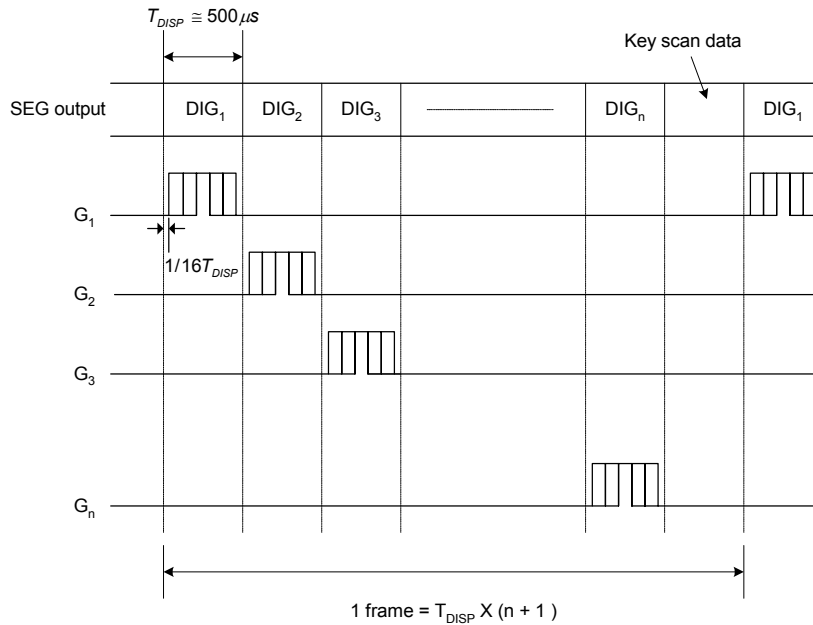

Note : One cycle of key scanning consists of two frame, and data in 1 16 X 2 matrix is stored in RAM.

(6) Key Scan Expansion

1st frame		1	2	3	4	5	6	7	8	
2nd frame	DIG _n	9	10	11	12	13	14	15	16	DIG ₁

(7) Serial Communication Format

Reception (command/data write)

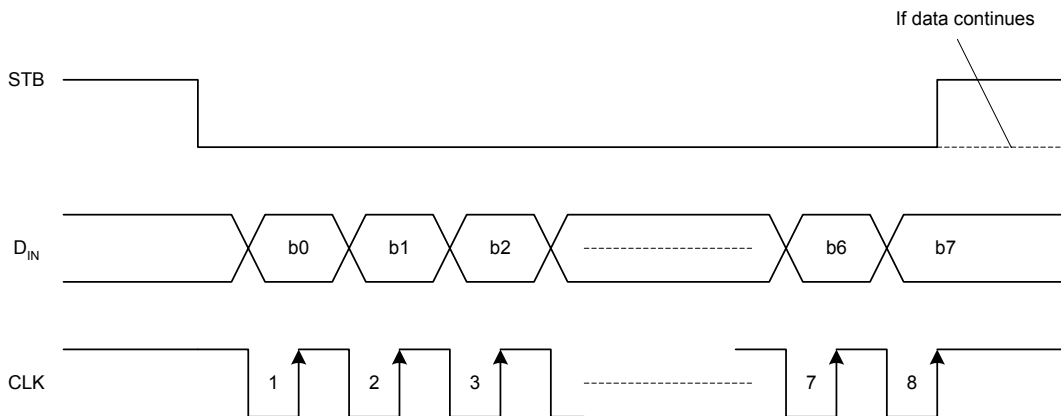

1/4- to 1/12 Duty VFD Controller/Driver

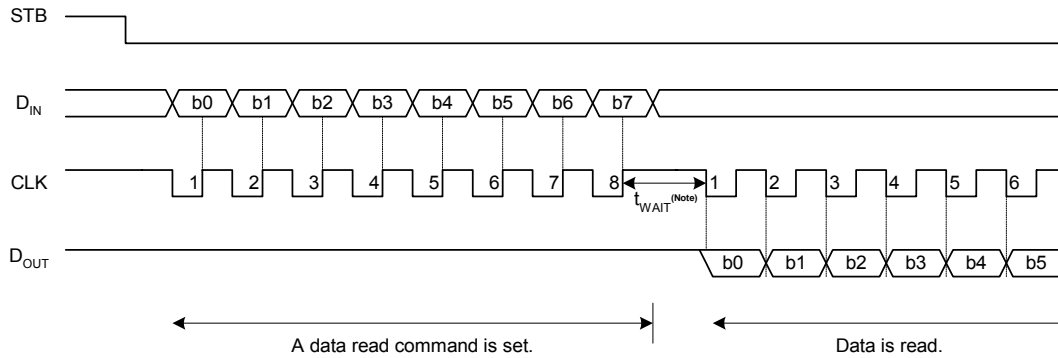

Transmission (data read)

Note : When data is read, a wait time t_{WAIT} of 1 μ s is necessary since the rising of the eighth clock that has set the command, until the falling of the first clock that has read the data.

Remark : Because the D_{OUT} pin is an N-ch, open-drain output pin, be sure to connect an external pull-up resistor (1 k Ω to 10 k Ω) to this pin.

(8) Switching Characteristic Waveforms

Typical Characteristics (Unless otherwise specified, $T_A = 25^\circ\text{C}$, $V_{DD} = 5\text{V}$, $V_{EE} = V_{DD} - 35\text{V}$)

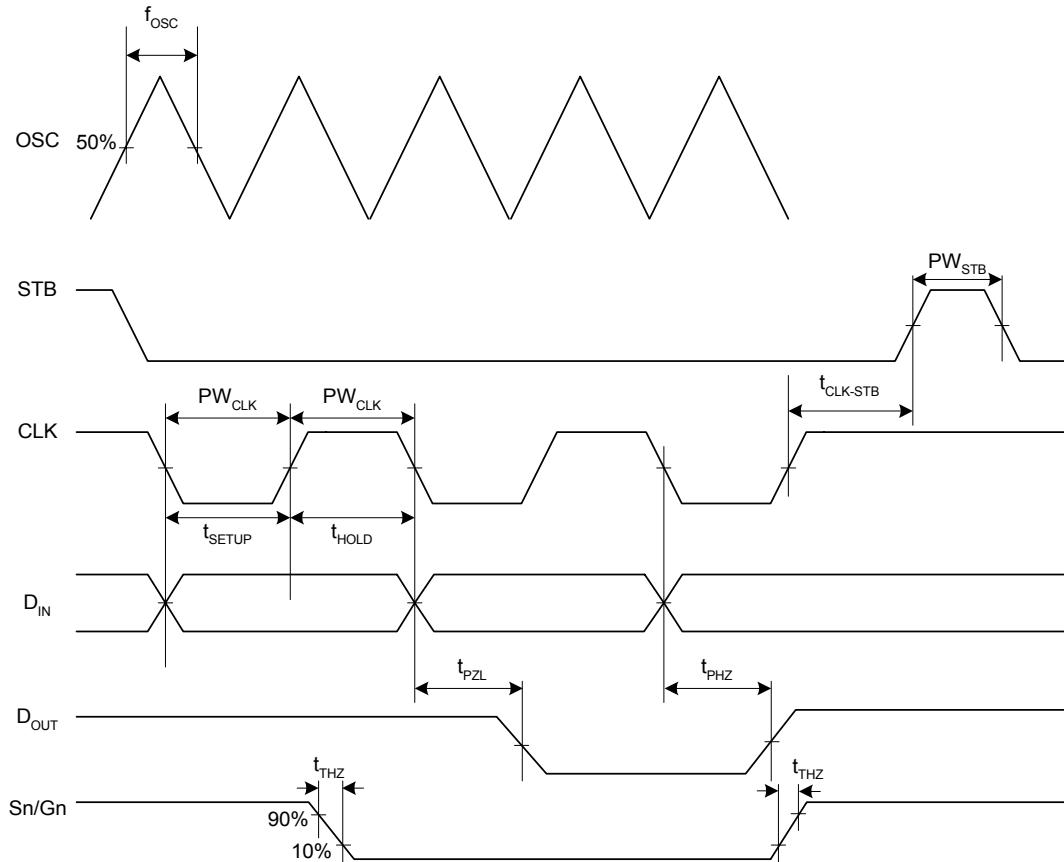

(9) Applications

Updating display memory by incrementing address

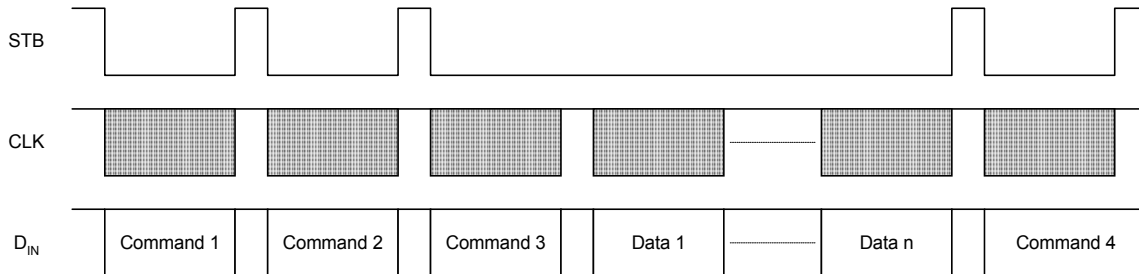

- Command 1 : sets display mode
- Command 2 : sets data
- Command 3 : sets address
- Data 1 to n : transfers display data (36 bytes MAX.)
- Command 4 : controls display

Updating specific address

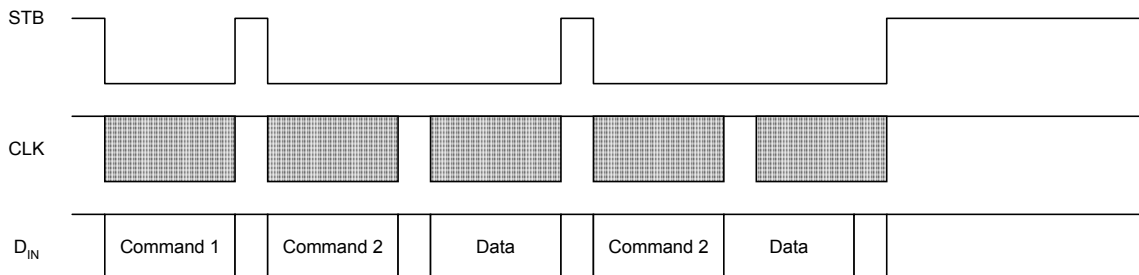

- Command 1 : sets data
- Command 2 : sets address
- Data : display data

■ Application Circuit

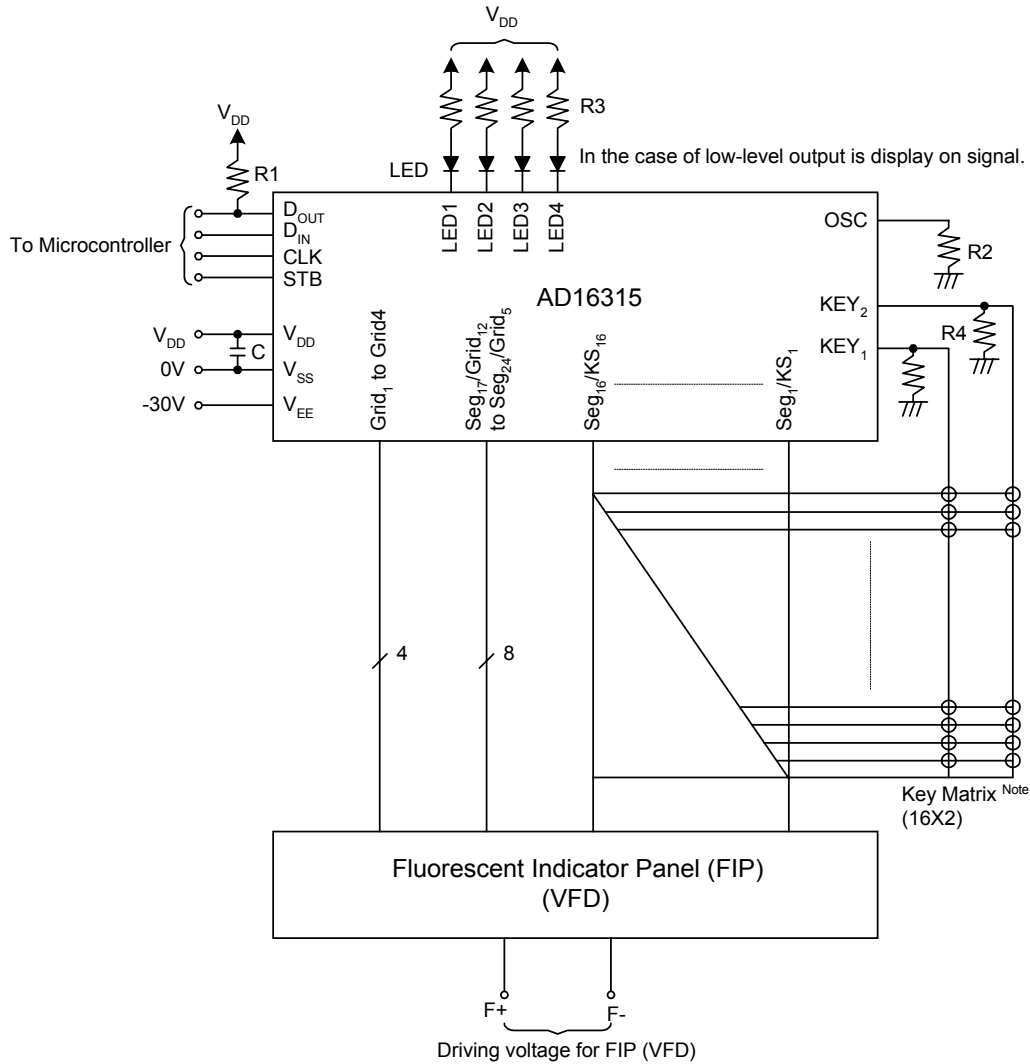

Note :

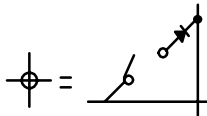

Remark : R1,R4 = 1k to 10kΩ
 R2 = 82kΩ
 R3= 330 TO 1KΩ
 C = 0.1μ to 1.0μF

■ Package Information

(1) Package Type: Plastic QFP-44L

Dimension in millimeter (mm.).

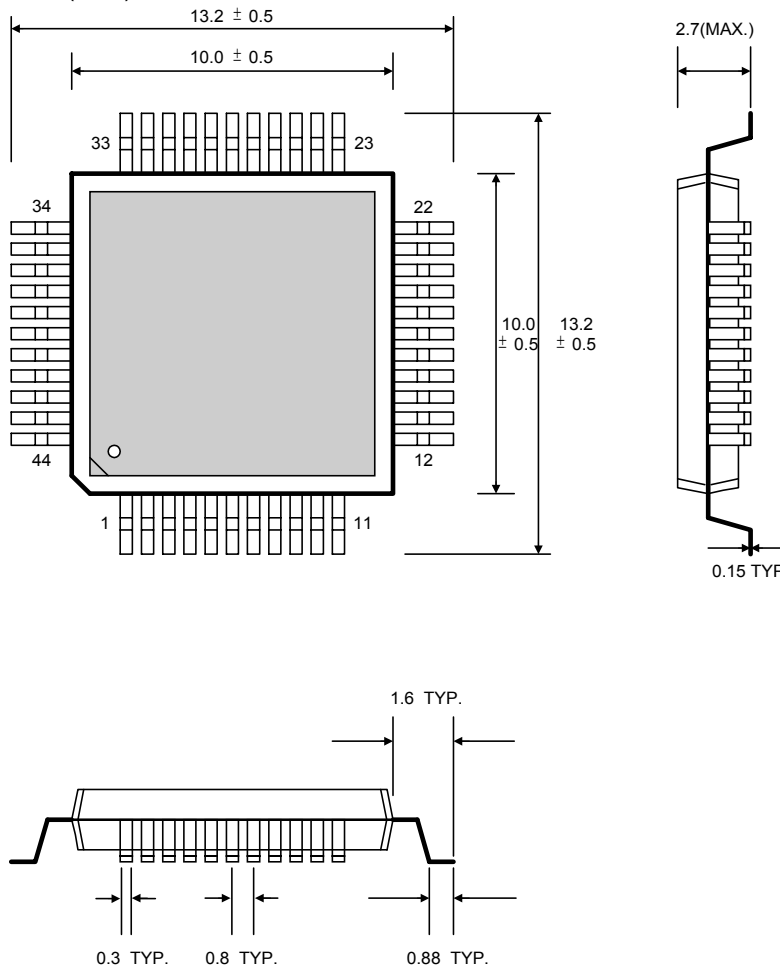

1/4- to 1/12 Duty VFD Controller/Driver

(2) Package Type: LQFP-44L

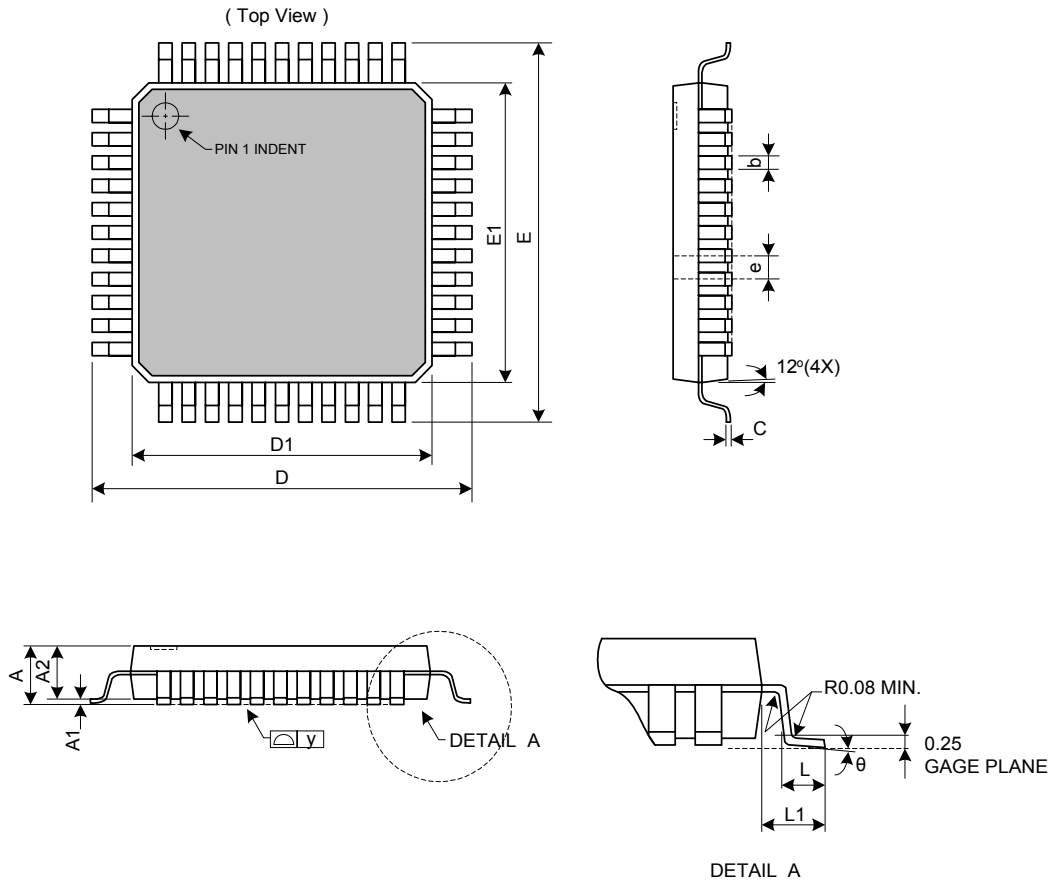

Symbol	Dimensions In Millimeters			Dimensions In Inches		
	Min.	Nom.	Max.	Min.	Nom.	Max.
A	-	-	1.60	-	-	0.063
A1	0.05	0.10	0.15	0.002	0.004	0.006
A2	1.35	1.40	1.45	0.053	0.055	0.057
b	0.30	0.37	0.45	0.012	0.015	0.018
C	0.09	-	0.20	0.004	-	0.008
E	11.50	12.00	12.50	0.453	0.472	0.492
E1	9.50	10.00	10.50	0.374	0.394	0.413
D	11.80	12.00	12.20	0.465	0.472	0.480
D1	9.90	10.00	10.10	0.390	0.394	0.398
e	-	0.80	-	-	0.031	-
L	0.45	0.60	0.75	0.018	0.024	0.030
L1	-	1.00	-	-	0.039	-
θ	0°	3.5°	7°	0°	3.5°	7°
y	0.00	-	0.08	0.000	-	0.003

■ Marking Information

