

---

## 2x10W Stereo / 1x20W Mono Digital Audio Amplifier

---

**Features**

- 16/18/20/24-bit input with I<sup>2</sup>S, Left-alignment and Right-alignment data format
- PSNR & DR (A-weighting)  
Loudspeaker: 97dB (PSNR), 101dB (DR) @18V
- Multiple sampling frequencies (Fs)  
32kHz / 44.1kHz / 48kHz and  
64kHz / 88.2kHz / 96kHz and  
128kHz/176.4kHz/192kHz
- System clock = 64x, 128x, 256x, 384x, 512x, 768x, 1024x Fs  
256x~1024x Fs for 32kHz / 44.1kHz / 48kHz  
128x~512x Fs for 64kHz / 88.2kHz / 96kHz  
64x~256x Fs for 128kHz/176.4kHz/192kHz
- Supply voltage  
3.3V for digital circuit  
12V~18V for loudspeaker driver
- Loudspeaker output power for 18V  
10W x 2CH into 8Ω @0.35% THD+N for stereo  
20W x 1CH into 4Ω @0.32% THD+N for mono
- Anti-pop design
- Over-temperature protection
- Internal PLL
- Under-voltage shutdown
- Over-current protection
- I<sup>2</sup>C control interface

- Zero detection
- Power limit function
- Quaternary and ternary switch

**Applications**

- CD and DVD
- LCD TV
- Car audio
- Boom-box
- MP3 docking systems
- Powered speaker
- Wireless audio
- USB speaker

**Description**

AD82571 is a digital audio amplifier capable of driving a pair of 8Ω,10W or a single 4Ω,20W speaker, both which operate at a 18V supply without external heat-sink or fan requirement.

Using I<sup>2</sup>C digital control interface, the user can control AD82571's input format selection, mute and volume control functions. AD82571 has many built-in protection circuits to safeguard AD82571 from connection errors.

**ORDERING INFORMATION**

Product ID	Package	Packing / MPQ	Comments
AD82571-LE48NAY	E-LQFP-48L 7x7 mm	Tray 2.5K Units / Box	Green
AD82571-EF48NAR	QFN-48L 7x7 mm	Tape & Reel 3K Units / Box	Green

**Pin Assignment**

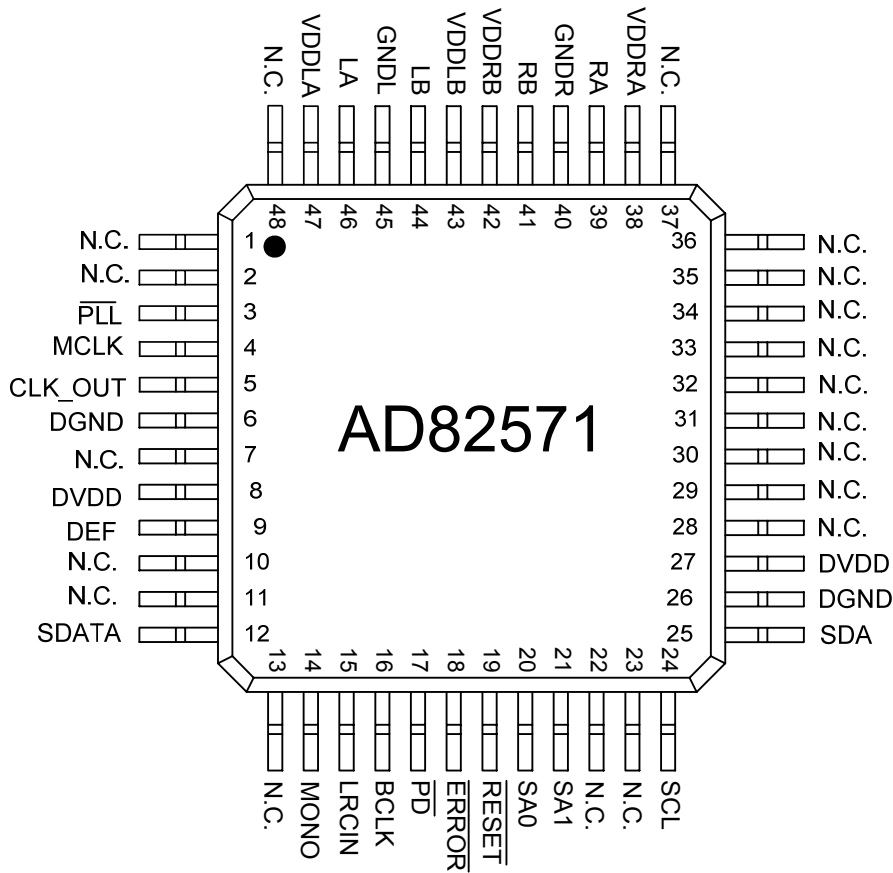

**Pin Description**

PIN	NAME	TYPE	DESCRIPTION	CHARACTERISTICS
1	N.C.	NC		
2	N.C.	NC		
3	PLL	I	PLL enable, low active	Schmitt trigger TTL input buffer
4	MCLK	I	Master clock input	Schmitt trigger TTL input buffer
5	CLK_OUT	O	Clock output from PLL	TTL output buffer
6	DGND	P	Digital Ground	
7	N.C.	NC		
8	DVDD	P	Digital Power	
9	DEF	I	Default volume setting	Schmitt trigger TTL input buffer
10	N.C.	NC		
11	N.C.	NC		
12	SDATA	I	Serial audio data input	Schmitt trigger TTL input buffer
13	N.C.	NC		
14	MONO	I	MONO mode enable, high active	Schmitt trigger TTL input buffer

15	LRCIN	I	Left/Right clock input (Fs)	Schmitt trigger TTL input buffer
16	BCLK	I	Bit clock input (64Fs)	Schmitt trigger TTL input buffer
17	$\overline{\text{PD}}$	I	Power down, low active	Schmitt trigger TTL input buffer
18	$\overline{\text{ERROR}}$	O	Error status, low active	Open-drain output
19	$\overline{\text{RESET}}$	I	Reset, low active	Schmitt trigger TTL input buffer
20	SA0	I	I <sup>2</sup> C select address 0	Schmitt trigger TTL input buffer
21	SA1	I	I <sup>2</sup> C select address 1	Schmitt trigger TTL input buffer
22	N.C.	NC		
23	N.C.	NC		
24	SCL	I	I <sup>2</sup> C serial clock input	Schmitt trigger TTL input buffer
25	SDA	I/O	I <sup>2</sup> C bi-directional serial data	Schmitt trigger TTL input buffer
26	DGND	P	Digital Ground	
27	DVDD	P	Digital Power	
28	N.C.	NC		
29	N.C.	NC		
30	N.C.	NC		
31	N.C.	NC		
32	N.C.	NC		
33	N.C.	NC		
34	N.C.	NC		
35	N.C.	NC		
36	N.C.	NC		
37	N.C.	NC		
38	VDDRA	P	Right channel supply A	
39	RA	O	Right channel output A	
40	GNDR	P	Right channel ground	
41	RB	O	Right channel output B	
42	VDDR B	P	Right channel supply B	
43	VDDL B	P	Left channel supply B	
44	LB	O	Left channel output B	
45	GNDL	P	Left channel ground	
46	LA	O	Left channel output A	
47	VDDL A	P	Left channel supply A	
48	N.C.	NC		