

# ADC1015S series

www.DataSheet4U.com

Single 10-bit ADC; 65 Msps, 80 Msps, 105 Msps or 125 Msps with input buffer; CMOS or LVDS DDR digital outputs

Rev. 01 — 12 April 2010

Preliminary data sheet

## 1. General description

The ADC1015S is a single channel 10-bit Analog-to-Digital Converter (ADC) optimized for high dynamic performances and low power consumption at sample rates up to 125 Msps. Pipelined architecture and output error correction ensure the ADC1015S is accurate enough to guarantee zero missing codes over the entire operating range. Supplied from a single 3 V source, it can handle output logic levels from 1.8 V to 3.3 V in CMOS mode, thanks to a separate digital output supply.

The ADC1015S supports the Low Voltage Differential Signalling (LVDS) Double Data Rate (DDR) output standard. An integrated Serial Peripheral Interface (SPI) allows the user to easily configure the ADC.

The device also includes a SPI programmable full-scale to allow flexible input voltage range from 1 V to 2 V (peak-to-peak). With excellent dynamic performance from the baseband to input frequencies of 170 MHz or more, the ADC1015S is ideal for use in communications, imaging and medical applications - especially in high Intermediate Frequency (IF) applications thanks to the integrated input buffer. The input buffer ensures that the input impedance remains constant and low and the performance consistent over a wide frequency range.

## 2. Features and benefits

- SNR, 61.7 dBFS / SFDR, 86 dBc
- Sample rate up to 125 Msps
- 10-bit pipelined ADC core
- Clock input divider by 2 for less jitter contribution
- Integrated input buffer
- Flexible input voltage range: 1 V (p-p) to 2 V (p-p)
- CMOS or LVDS DDR digital outputs
- Pin compatible with the ADC1415S series, the ADC1215S series and the ADC1115S125
- HVQFN40 package
- Input bandwidth, 600 MHz
- Power dissipation, 635 mW at 80 Msps, including analog input buffer
- SPI
- Duty cycle stabilizer
- Fast Out of Range (OTR) detection
- INL  $\pm 1.25$  LSB, DNL  $\pm 0.25$  LSB
- Offset binary, two's complement, gray code
- Power-down and Sleep modes



www.DataSheet4U.com

### 3. Applications

- Wireless and wired broadband communications
- Portable instrumentation
- Imaging systems
- Digital predistortion loop, power amplifier linearization
- Spectral analysis
- Ultrasound equipment
- Software defined radio

### 4. Ordering information

Table 1. Ordering information

| Type number      | f <sub>s</sub> (MSPs) | Package |  |          |
|------------------|-----------------------|---------|--|----------|
|                  |                       | Name    | Description  | Version  |
| ADC1015S125HN/C1 | 125                   | HVQFN40 | plastic thermal enhanced very thin quad flat package; no leads; 40 terminals; body 6 × 6 × 0.85 mm | SOT618-6 |
| ADC1015S105HN/C1 | 105                   | HVQFN40 | plastic thermal enhanced very thin quad flat package; no leads; 40 terminals; body 6 × 6 × 0.85 mm | SOT618-6 |
| ADC1015S080HN/C1 | 80                    | HVQFN40 | plastic thermal enhanced very thin quad flat package; no leads; 40 terminals; body 6 × 6 × 0.85 mm | SOT618-6 |
| ADC1015S065HN/C1 | 65                    | HVQFN40 | plastic thermal enhanced very thin quad flat package; no leads; 40 terminals; body 6 × 6 × 0.85 mm | SOT618-6 |

5. Block diagram

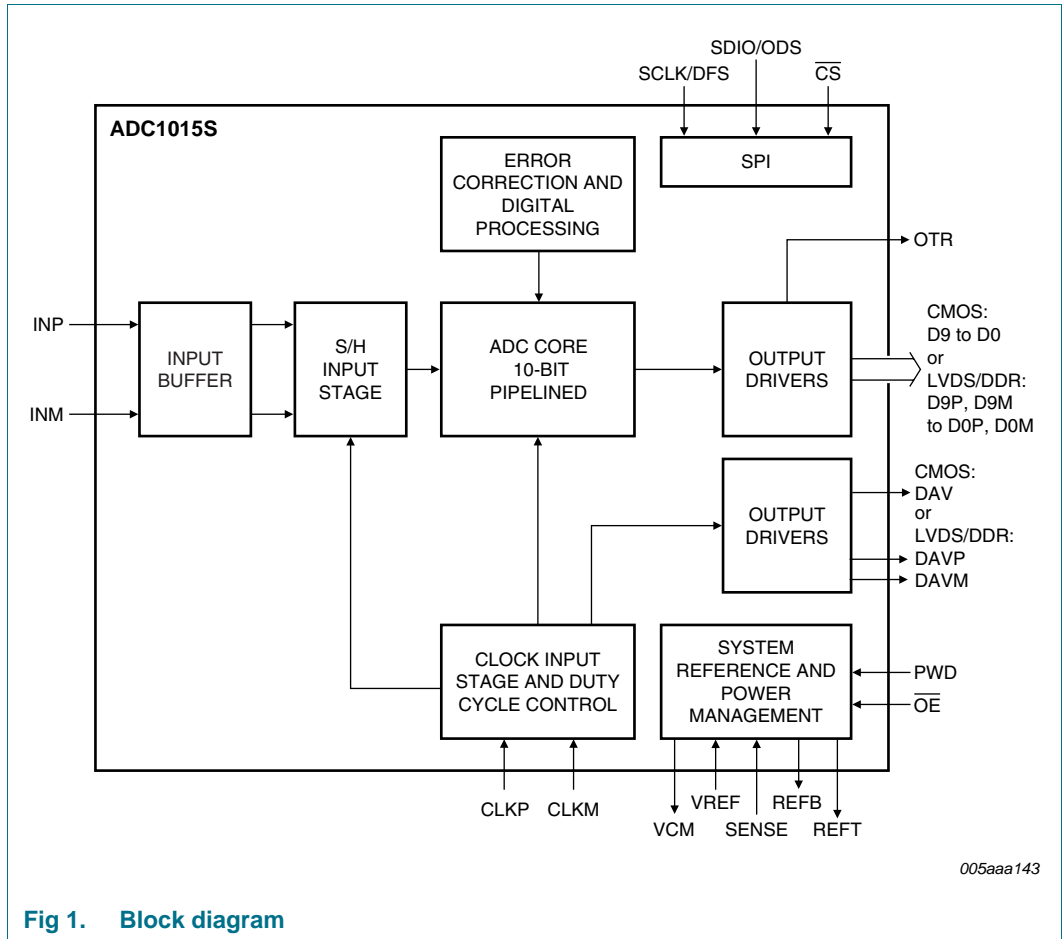

Fig 1. Block diagram

## 6. Pinning information

### 6.1 Pinning

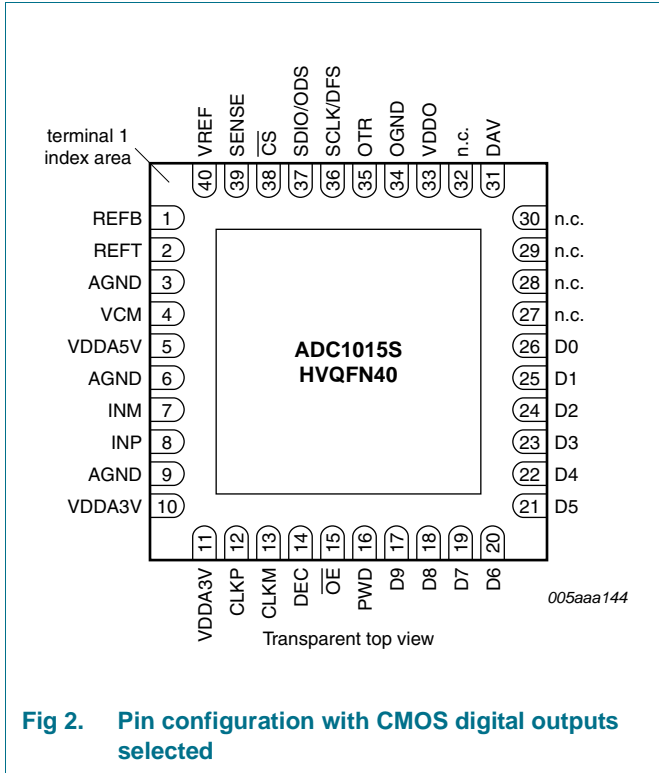

Fig 2. Pin configuration with CMOS digital outputs selected

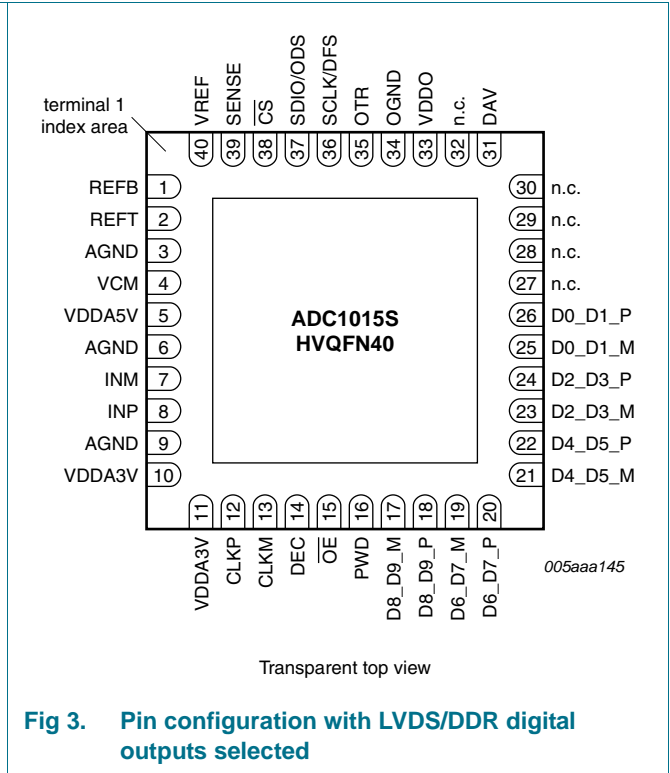

Fig 3. Pin configuration with LVDS/DDR digital outputs selected

### 6.2 Pin description

Table 2. Pin description (CMOS digital outputs)

| Symbol | Pin | Type <sup>[1]</sup> | Description                |
|--------|-----|---------------------|----------------------------|
| REFB   | 1   | O                   | bottom reference           |
| REFT   | 2   | O                   | top reference              |
| AGND   | 3   | G                   | analog ground              |
| VCM    | 4   | O                   | common-mode output voltage |
| VDDA5V | 5   | P                   | 5 V analog power supply    |
| AGND   | 6   | G                   | analog ground              |
| INM    | 7   | I                   | complementary analog input |
| INP    | 8   | I                   | analog input               |
| AGND   | 9   | G                   | analog ground              |
| VDDA3V | 10  | P                   | 3 V analog power supply    |
| VDDA3V | 11  | P                   | 3 V analog power supply    |
| CLKP   | 12  | I                   | clock input                |
| CLKM   | 13  | I                   | complementary clock input  |
| DEC    | 14  | O                   | regulator decoupling node  |
| OE     | 15  | I                   | output enable, active LOW  |
| PWD    | 16  | I                   | power down, active HIGH    |

Table 2. Pin description (CMOS digital outputs)

| Symbol                 | Pin | Type <sup>[1]</sup> | Description                        |
|------------------------|-----|---------------------|------------------------------------|
| D9                     | 17  | O                   | data output bit 9 (MSB)            |
| D8                     | 18  | O                   | data output bit 8                  |
| D7                     | 19  | O                   | data output bit 7                  |
| D6                     | 20  | O                   | data output bit 6                  |
| D5                     | 21  | O                   | data output bit 5                  |
| D4                     | 22  | O                   | data output bit 4                  |
| D3                     | 23  | O                   | data output bit 3                  |
| D2                     | 24  | O                   | data output bit 2                  |
| D1                     | 25  | O                   | data output bit 1                  |
| D0                     | 26  | O                   | data output bit 0 (LSB)            |
| n.c.                   | 27  | -                   | not connected                      |
| n.c.                   | 28  | -                   | not connected                      |
| n.c.                   | 29  | -                   | not connected                      |
| n.c.                   | 30  | -                   | not connected                      |
| DAV                    | 31  | O                   | data valid output clock            |
| n.c.                   | 32  | -                   | not connected                      |
| VDDO                   | 33  | P                   | output power supply                |
| OGND                   | 34  | G                   | output ground                      |
| OTR                    | 35  | O                   | out of range                       |
| SCLK/DFS               | 36  | I                   | SPI clock / data format select     |
| SDIO/ODS               | 37  | I/O                 | SPI data IO / output data standard |
| $\overline{\text{CS}}$ | 38  | I                   | SPI chip select                    |
| SENSE                  | 39  | I                   | reference programming pin          |
| VREF                   | 40  | I/O                 | voltage reference input/output     |

[1] P: power supply; G: ground; I: input; O: output; I/O: input/output.

Table 3. Pin description (LVDS/DDR) digital outputs

| Symbol  | Pin <sup>[1]</sup> | Type <sup>[2]</sup> | Description  |
|---------|--------------------|---------------------|--|
| D8_D9_M | 17                 | O                   | differential output data D8 and D9 multiplexed, complement |
| D8_D9_P | 18                 | O                   | differential output data D8 and D9 multiplexed, true       |
| D6_D7_M | 19                 | O                   | differential output data D6 and D7 multiplexed, complement |
| D6_D7_P | 20                 | O                   | differential output data D6 and D7 multiplexed, true       |
| D4_D5_M | 21                 | O                   | differential output data D4 and D5 multiplexed, complement |
| D4_D5_P | 22                 | O                   | differential output data D4 and D5 multiplexed, true       |
| D2_D3_M | 23                 | O                   | differential output data D2 and D3 multiplexed, complement |
| D2_D3_P | 24                 | O                   | differential output data D2 and D3 multiplexed, true       |
| D0_D1_M | 25                 | O                   | differential output data D0 and D1 multiplexed, complement |
| D0_D1_P | 26                 | O                   | differential output data D0 and D1 multiplexed, true       |
| n.c.    | 27                 | -                   | not connected  |
| n.c.    | 28                 | -                   | not connected  |
| n.c.    | 29                 | -                   | not connected  |

**Table 3. Pin description ...continued (LVDS/DDR) digital outputs)**

| Symbol | Pin <sup>[1]</sup> | Type <sup>[2]</sup> | Description                         |
|--------|--------------------|---------------------|-------------------------------------|
| n.c.   | 30                 | -                   | not connected                       |
| DAVM   | 31                 | O                   | data valid output clock, complement |
| DAVP   | 32                 | O                   | data valid output clock, true       |

[1] Pins 1 to 16 and pins 33 to 40 are the same for both CMOS and LVDS DDR outputs (see [Table 2](#))

[2] P: power supply; G: ground; I: input; O: output; I/O: input/output.

## 7. Limiting values

**Table 4. Limiting values**

In accordance with the Absolute Maximum Rating System (IEC 60134).

| Symbol          | Parameter                 | Conditions                                      | Min   | Max   | Unit |
|-----------------|---------------------------|---|-------|-------|------|
| $V_O$           | output voltage            | pins D9 to D0 or pins D9P to D0P and D9M to D0M | -0.4  | +3.9  | V    |
| $V_{DDA(3V)}$   | analog supply voltage 3 V | on pin VDDA3V                                   | -0.5  | +4.6  | V    |
| $V_{DDA(5V)}$   | analog supply voltage 5 V | on pin VDDA5V                                   | -0.5  | +4.6  | V    |
| $V_{DDO}$       | output supply voltage     |   | -0.5  | +4.6  | V    |
| $\Delta V_{CC}$ | supply voltage difference | $V_{DDA(3V)} - V_{DDO}$                         | <tbd> | <tbd> | V    |
| $T_{stg}$       | storage temperature       |   | -55   | +125  | °C   |
| $T_{amb}$       | ambient temperature       |   | -40   | +85   | °C   |
| $T_j$           | junction temperature      |   | -     | 125   | °C   |

## 8. Thermal characteristics

**Table 5. Thermal characteristics**

| Symbol        | Parameter                                   | Conditions | Typ                 | Unit |
|---------------|---|------------|---------------------|------|
| $R_{th(j-a)}$ | thermal resistance from junction to ambient |            | <sup>[1]</sup> 30.5 | K/W  |
| $R_{th(j-c)}$ | thermal resistance from junction to case    |            | <sup>[1]</sup> 13.3 | K/W  |

[1] Value for six layers board in still air with a minimum of 25 thermal vias.

## 9. Static characteristics

Table 6. Static characteristics<sup>[1]</sup>

| Symbol                                  | Parameter                        | Conditions  | Min              | Typ        | Max              | Unit    |
|---|----------------------------------|---|------------------|------------|------------------|---------|
| <b>Supplies</b>                         |                                  |   |                  |            |                  |         |
| $V_{DDA(5V)}$                           | analog supply voltage 5 V        |   | 4.75             | 5.0        | 5.25             | V       |
| $V_{DDA(3V)}$                           | analog supply voltage 3 V        |   | 2.85             | 3.0        | 3.4              | V       |
| $V_{DDO}$                               | output supply voltage            | CMOS mode   | 1.65             | 1.8        | 3.6              | V       |
|   |                                  | LVDS DDR mode   | 2.85             | 3.0        | 3.6              | V       |
| $I_{DDA(5V)}$                           | analog supply current 5 V        | $f_{clk} = 125$ Msps;<br>$f_i = 70$ MHz                   | -                | 46         | -                | mA      |
| $I_{DDA(3V)}$                           | analog supply current 3 V        | $f_{clk} = 125$ Msps;<br>$f_i = 70$ MHz                   | -                | 205        | -                | mA      |
| $I_{DDO}$                               | output supply current            | CMOS mode;<br>$f_{clk} = 125$ Msps;<br>$f_i = 70$ MHz     | -                | 10         | -                | mA      |
|   |                                  | LVDS DDR mode:<br>$f_{clk} = 125$ Msps;<br>$f_i = 70$ MHz | -                | 35         | -                | mA      |
| P                                       | power dissipation                | ADC1015S125;<br>analog supply only                        | -                | 840        | -                | mW      |
|   |                                  | ADC1015S105;<br>analog supply only                        | -                | 770        | -                | mW      |
|   |                                  | ADC1015S080;<br>analog supply only                        | -                | 635        | -                | mW      |
|   |                                  | ADC1015S065;<br>analog supply only                        | -                | 580        | -                | mW      |
|   |                                  | Power-down mode   | -                | 2          | -                | mW      |
|   |                                  | Standby mode  | -                | 40         | -                | mW      |
| <b>Clock inputs: pins CLKP and CLKM</b> |                                  |   |                  |            |                  |         |
| <b>LVPECL</b>                           |                                  |   |                  |            |                  |         |
| $V_{i(clk)dif}$                         | differential clock input voltage | peak-to-peak  | -                | $\pm 1.6$  | -                | V       |
| <b>LVDS</b>                             |                                  |   |                  |            |                  |         |
| $V_{i(clk)dif}$                         | differential clock input voltage | peak-to-peak  | -                | $\pm 0.70$ | -                | V       |
| <b>SINE wave</b>                        |                                  |   |                  |            |                  |         |
| $V_{i(clk)dif}$                         | differential clock input voltage | peak-to-peak  | $\pm 0.8$        | $\pm 3.0$  | -                | V       |
| <b>LVC MOS</b>                          |                                  |   |                  |            |                  |         |
| $V_{IL}$                                | LOW-level input voltage          |   | -                | -          | $0.3V_{DDA(3V)}$ | V       |
| $V_{IH}$                                | HIGH-level input voltage         |   | $0.7V_{DDA(3V)}$ | -          | -                | V       |
| <b>Logic inputs: pins PWD and OE</b>    |                                  |   |                  |            |                  |         |
| $V_{IL}$                                | LOW-level input voltage          |   | 0                | -          | 0.8              | V       |
| $V_{IH}$                                | HIGH-level input voltage         |   | 2                | -          | $V_{DDA(3V)}$    | V       |
| $I_{IL}$                                | LOW-level input current          |   | <tbd>            | -          | <tbd>            | $\mu$ A |
| $I_{IH}$                                | HIGH-level input current         |   | -10              | -          | +10              | $\mu$ A |

Table 6. Static characteristics<sup>[1]</sup> ...continued

| Symbol  | Parameter                   | Conditions                                      | Min                     | Typ                     | Max                     | Unit |
|---|-----------------------------|---|-------------------------|-------------------------|-------------------------|------|
| <b>Serial peripheral interface: pins CS, SDIO/ODS, SCLK/DFS</b>               |                             |   |                         |                         |                         |      |
| V <sub>IL</sub>   | LOW-level input voltage     |   | 0                       | -                       | 0.3V <sub>DDA(3V)</sub> | V    |
| V <sub>IH</sub>   | HIGH-level input voltage    |   | 0.7V <sub>DDA(3V)</sub> | -                       | V <sub>DDA(3V)</sub>    | V    |
| I <sub>IL</sub>   | LOW-level input current     |   | -10                     | -                       | +10                     | μA   |
| I <sub>IH</sub>   | HIGH-level input current    |   | -50                     | -                       | +50                     | μA   |
| C <sub>i</sub>  | input capacitance           |   | -                       | 4                       | -                       | pF   |
| <b>Digital outputs, CMOS mode: pins D9 to D0, OTR, DAV</b>                    |                             |   |                         |                         |                         |      |
| Output levels, V <sub>DDO</sub> = 3 V   |                             |   |                         |                         |                         |      |
| V <sub>OL</sub>   | LOW-level output voltage    | I <sub>OL</sub> = <td>                          | OGND                    | -                       | 0.2V <sub>DDO</sub>     | V    |
| V <sub>OH</sub>   | HIGH-level output voltage   | I <sub>OH</sub> = <td>                          | 0.8V <sub>DDO</sub>     | -                       | V <sub>DDO</sub>        | V    |
| I <sub>OL</sub>   | LOW-level output current    | 3-state;<br>output level = 0 V                  | -                       | <td>                    | -                       | μA   |
| I <sub>OH</sub>   | HIGH-level output current   | 3-state;<br>output level = V <sub>DDA(3V)</sub> | -                       | <td>                    | -                       | μA   |
| C <sub>O</sub>  | output capacitance          | high impedance;<br>OE = HIGH                    | -                       | 3                       | -                       | pF   |
| Output levels, V <sub>DDO</sub> = 1.8 V                                       |                             |   |                         |                         |                         |      |
| V <sub>OL</sub>   | LOW-level output voltage    | I <sub>OL</sub> = <td>                          | OGND                    | -                       | 0.2V <sub>DDO</sub>     | V    |
| V <sub>OH</sub>   | HIGH-level output voltage   | I <sub>OH</sub> = <td>                          | 0.8V <sub>DDO</sub>     | -                       | V <sub>DDO</sub>        | V    |
| <b>Digital outputs, LVDS mode: pins D9P to D0P, D9M to D0M, DAVP and DAVM</b> |                             |   |                         |                         |                         |      |
| Output levels, V <sub>DDO</sub> = 3 V only, R <sub>load</sub> = 100 Ω         |                             |   |                         |                         |                         |      |
| V <sub>O(offset)</sub>  | output offset voltage       | output buffer current<br>set to 3.5 mA          | -                       | 1.2                     | -                       | V    |
| V <sub>O(dif)</sub>   | differential output voltage | output buffer current<br>set to 3.5 mA          | -                       | 350                     | -                       | mV   |
| C <sub>O</sub>  | output capacitance          |   | -                       | <td>                    | -                       | pF   |
| <b>Analog inputs: pins INP and INM</b>  |                             |   |                         |                         |                         |      |
| I <sub>I</sub>  | input current               |   | -5                      | -                       | +5                      | μA   |
| R <sub>I</sub>  | input resistance            |   | -                       | 550                     | -                       | Ω    |
| C <sub>I</sub>  | input capacitance           |   | -                       | 1.3                     | -                       | pF   |
| V <sub>I(cm)</sub>  | common-mode input voltage   | V <sub>INP</sub> = V <sub>INM</sub>             | 0.9                     | 1.5                     | 2                       | V    |
| B <sub>i</sub>  | input bandwidth             |   | -                       | 600                     | -                       | MHz  |
| V <sub>I(dif)</sub>   | differential input voltage  | peak-to-peak                                    | 1                       |                         | 2                       | V    |
| <b>Common mode output voltage: pin VCM</b>                                    |                             |   |                         |                         |                         |      |
| V <sub>O(cm)</sub>  | common-mode output voltage  |   | -                       | 0.5V <sub>DDA(3V)</sub> | -                       | V    |
| I <sub>O(cm)</sub>  | common-mode output current  |   | -                       | <td>                    | -                       | μA   |



Table 6. Static characteristics<sup>[1]</sup> ...continued

| Symbol                                 | Parameter                    | Conditions                           | Min   | Typ      | Max   | Unit |
|--|------------------------------|--------------------------------------|-------|----------|-------|------|
| <b>I/O reference voltage: pin VREF</b> |                              |                                      |       |          |       |      |
| V <sub>VREF</sub>                      | voltage on pin VREF          | output                               | -     | 0.5 to 1 | -     | V    |
|  |                              | input                                | 0.5   | -        | 1     | V    |
| <b>Accuracy</b>                        |                              |                                      |       |          |       |      |
| INL                                    | integral non-linearity       |                                      | -0.4  | ±0.07    | +0.4  | LSB  |
| DNL                                    | differential non-linearity   | guaranteed no missing codes          | -0.06 | ±0.04    | +0.06 | LSB  |
| E <sub>offset</sub>                    | offset error                 |                                      | -     | ±2       | -     | mV   |
| E <sub>G</sub>                         | gain error                   |                                      | -     | ±0.5     | -     | %FS  |
| <b>Supply</b>                          |                              |                                      |       |          |       |      |
| PSRR                                   | power supply rejection ratio | 100 mV (p-p) on V <sub>DDA(3V)</sub> | -     | 35       | -     | dBc  |

[1] Typical values measured at V<sub>DDA(3V)</sub> = 3 V, V<sub>DDO</sub> = 1.8 V, V<sub>DDA(5V)</sub> = 5 V; T<sub>amb</sub> = 25 °C and C<sub>L</sub> = 5 pF; minimum and maximum values are across the full temperature range T<sub>amb</sub> = -40 °C to +85 °C at V<sub>DDA(3V)</sub> = 3 V, V<sub>DDO</sub> = 1.8 V, V<sub>DDA(5V)</sub> = 5 V, V<sub>INP</sub> - V<sub>INM</sub> = -1 dBFS; internal reference mode; applied to CMOS and LVDS interface; unless otherwise specified.

## 10. Dynamic characteristics

### 10.1 Dynamic characteristics

Table 7. Dynamic characteristics<sup>[1]</sup>

| Symbol                          | Parameter                   | Conditions      | ADC1015S065 |      |     | ADC1015S080 |      |     | ADC1015S105 |      |     | ADC1015S125 |      |     | Unit |
|---------------------------------|-----------------------------|-----------------|-------------|------|-----|-------------|------|-----|-------------|------|-----|-------------|------|-----|------|
|                                 |                             |                 | Min         | Typ  | Max | Min         | Typ  | Max | Min         | Typ  | Max | Min         | Typ  | Max |      |
| <b>Analog signal processing</b> |                             |                 |             |      |     |             |      |     |             |      |     |             |      |     |      |
| $\alpha_{2H}$                   | second harmonic level       | $f_i = 3$ MHz   | -           | 87   | -   | -           | 87   | -   | -           | 86   | -   | -           | 88   | -   | dBc  |
|                                 |                             | $f_i = 30$ MHz  | -           | 86   | -   | -           | 86   | -   | -           | 86   | -   | -           | 87   | -   | dBc  |
|                                 |                             | $f_i = 70$ MHz  | -           | 85   | -   | -           | 85   | -   | -           | 84   | -   | -           | 85   | -   | dBc  |
|                                 |                             | $f_i = 170$ MHz | -           | 82   | -   | -           | 82   | -   | -           | 81   | -   | -           | 83   | -   | dBc  |
| $\alpha_{3H}$                   | third harmonic level        | $f_i = 3$ MHz   | -           | 86   | -   | -           | 86   | -   | -           | 85   | -   | -           | 87   | -   | dBc  |
|                                 |                             | $f_i = 30$ MHz  | -           | 85   | -   | -           | 85   | -   | -           | 85   | -   | -           | 86   | -   | dBc  |
|                                 |                             | $f_i = 70$ MHz  | -           | 84   | -   | -           | 84   | -   | -           | 83   | -   | -           | 84   | -   | dBc  |
|                                 |                             | $f_i = 170$ MHz | -           | 81   | -   | -           | 81   | -   | -           | 80   | -   | -           | 82   | -   | dBc  |
| THD                             | total harmonic distortion   | $f_i = 3$ MHz   | -           | 85   | -   | -           | 85   | -   | -           | 84   | -   | -           | 86   | -   | dBc  |
|                                 |                             | $f_i = 30$ MHz  | -           | 84   | -   | -           | 84   | -   | -           | 84   | -   | -           | 85   | -   | dBc  |
|                                 |                             | $f_i = 70$ MHz  | -           | 83   | -   | -           | 83   | -   | -           | 82   | -   | -           | 83   | -   | dBc  |
|                                 |                             | $f_i = 170$ MHz | -           | 80   | -   | -           | 80   | -   | -           | 79   | -   | -           | 81   | -   | dBc  |
| ENOB                            | effective number of bits    | $f_i = 3$ MHz   | -           | 9.9  | -   | -           | 9.9  | -   | -           | 9.9  | -   | -           | 9.9  | -   | bits |
|                                 |                             | $f_i = 30$ MHz  | -           | 9.9  | -   | -           | 9.9  | -   | -           | 9.9  | -   | -           | 9.9  | -   | bits |
|                                 |                             | $f_i = 70$ MHz  | -           | 9.9  | -   | -           | 9.9  | -   | -           | 9.9  | -   | -           | 9.9  | -   | bits |
|                                 |                             | $f_i = 170$ MHz | -           | 9.9  | -   | -           | 9.9  | -   | -           | 9.9  | -   | -           | 9.9  | -   | bits |
| SNR                             | signal-to-noise ratio       | $f_i = 3$ MHz   | -           | 61.7 | -   | -           | 61.7 | -   | -           | 61.6 | -   | -           | 61.6 | -   | dBFS |
|                                 |                             | $f_i = 30$ MHz  | -           | 61.6 | -   | -           | 61.6 | -   | -           | 61.6 | -   | -           | 61.6 | -   | dBFS |
|                                 |                             | $f_i = 70$ MHz  | -           | 61.6 | -   | -           | 61.6 | -   | -           | 61.5 | -   | -           | 61.5 | -   | dBFS |
|                                 |                             | $f_i = 170$ MHz | -           | 61.5 | -   | -           | 61.5 | -   | -           | 61.5 | -   | -           | 61.5 | -   | dBFS |
| SFDR                            | spurious-free dynamic range | $f_i = 3$ MHz   | -           | 86   | -   | -           | 86   | -   | -           | 85   | -   | -           | 87   | -   | dBc  |
|                                 |                             | $f_i = 30$ MHz  | -           | 85   | -   | -           | 85   | -   | -           | 85   | -   | -           | 86   | -   | dBc  |
|                                 |                             | $f_i = 70$ MHz  | -           | 84   | -   | -           | 84   | -   | -           | 83   | -   | -           | 84   | -   | dBc  |
|                                 |                             | $f_i = 170$ MHz | -           | 81   | -   | -           | 81   | -   | -           | 80   | -   | -           | 82   | -   | dBc  |

Table 7. Dynamic characteristics<sup>[1]</sup> ...continued

| Symbol | Parameter                  | Conditions              | ADC1015S065 |     |     | ADC1015S080 |     |     | ADC1015S105 |     |     | ADC1015S125 |     |     | Unit |
|--------|----------------------------|-------------------------|-------------|-----|-----|-------------|-----|-----|-------------|-----|-----|-------------|-----|-----|------|
|        |                            |                         | Min         | Typ | Max | Min         | Typ | Max | Min         | Typ | Max | Min         | Typ | Max |      |
| IMD    | Intermodulation distortion | $f_i = 3 \text{ MHz}$   | -           | 89  | -   | -           | 89  | -   | -           | 88  | -   | -           | 89  | -   | dBc  |
|        |                            | $f_i = 30 \text{ MHz}$  | -           | 88  | -   | -           | 88  | -   | -           | 88  | -   | -           | 88  | -   | dBc  |
|        |                            | $f_i = 70 \text{ MHz}$  | -           | 87  | -   | -           | 87  | -   | -           | 86  | -   | -           | 86  | -   | dBc  |
|        |                            | $f_i = 170 \text{ MHz}$ | -           | 84  | -   | -           | 85  | -   | -           | 83  | -   | -           | 84  | -   | dBc  |

[1] Typical values measured at  $V_{DDA(3V)} = 3 \text{ V}$ ,  $V_{DDO} = 1.8 \text{ V}$ ,  $V_{DDA(5V)} = 5 \text{ V}$ ;  $T_{\text{amb}} = 25 \text{ }^\circ\text{C}$  and  $C_L = 5 \text{ pF}$ ; minimum and maximum values are across the full temperature range  $T_{\text{amb}} = -40 \text{ }^\circ\text{C}$  to  $+85 \text{ }^\circ\text{C}$  at  $V_{DDA(3V)} = 3 \text{ V}$ ,  $V_{DDO} = 1.8 \text{ V}$ ,  $V_{DDA(5V)} = 5 \text{ V}$ ,  $V_{\text{INP}} - V_{\text{INM}} = -1 \text{ dBFS}$ ; internal reference mode; applied to CMOS and LVDS interface; unless otherwise specified.

## 10.2 Clock and digital output timing

**Table 8. Clock and digital output timing characteristics<sup>[1]</sup>**

| Symbol  | Parameter                | Conditions | ADC1015S065 |      |     | ADC1015S080 |      |     | ADC1015S105 |      |     | ADC1015S125 |      |     | Unit        |
|---|--------------------------|------------|-------------|------|-----|-------------|------|-----|-------------|------|-----|-------------|------|-----|-------------|
|   |                          |            | Min         | Typ  | Max | Min         | Typ  | Max | Min         | Typ  | Max | Min         | Typ  | Max |             |
| <b>Clock timing input: pins CLKP and CLKM</b>         |                          |            |             |      |     |             |      |     |             |      |     |             |      |     |             |
| f <sub>clk</sub>                                      | clock frequency          |            | 20          | -    | 65  | 60          | -    | 80  | 75          | -    | 105 | 100         | -    | 125 | MHz         |
| t <sub>lat(data)</sub>                                | data latency time        |            | -           | 14   | -   | -           | 14   | -   | -           | 14   | -   | -           | 14   | -   | clock cycle |
| δ <sub>clk</sub>                                      | clock duty cycle         | DCS_EN = 1 | 30          | 50   | 70  | 30          | 50   | 70  | 30          | 50   | 70  | 30          | 50   | 70  | %           |
|   |                          | DCS_EN = 0 | 45          | 50   | 55  | 45          | 50   | 55  | 45          | 50   | 55  | 45          | 50   | 55  | %           |
| t <sub>d(s)</sub>                                     | sampling delay time      |            | -           | 0.8  | -   | -           | 0.8  | -   | -           | 0.8  | -   | -           | 0.8  | -   | ns          |
| t <sub>wake</sub>                                     | wake-up time             |            | -           | <td> | -   | -           | <td> | -   | -           | <td> | -   | -           | <td> | -   | ns          |
| <b>CMOS mode timing output: pins D9 to D0 and DAV</b> |                          |            |             |      |     |             |      |     |             |      |     |             |      |     |             |
| t <sub>PD</sub>                                       | propagation delay        | DATA       | -           | 3.9  | -   | -           | 3.9  | -   | -           | 3.9  | -   | -           | 3.9  | -   | ns          |
|   |                          | DAV        | -           | 4.2  | -   | -           | 4.2  | -   | -           | 4.2  | -   | -           | 4.2  | -   | ns          |
| t <sub>su</sub>                                       | set-up time              |            | -           | 7.7  | -   | -           | 6.5  | -   | -           | 4.7  | -   | -           | 4.3  | -   | ns          |
| t <sub>h</sub>  | hold time                |            | -           | 6.7  | -   | -           | 5.5  | -   | -           | 3.8  | -   | -           | 3.5  | -   | ns          |
| t <sub>r</sub>  | rise time <sup>[2]</sup> | DATA       | 0.5         | -    | 2.4 | 0.5         | -    | 2.4 | 0.5         | -    | 2.4 | 0.5         | -    | 2.4 | ns          |
|   |                          | DAV        | 0.5         | -    | 2.4 | 0.5         | -    | 2.4 | 0.5         | -    | 2.4 | 0.5         | -    | 2.4 | ns          |
| t <sub>f</sub>  | fall time <sup>[2]</sup> | DATA       | 0.5         | -    | 2.4 | 0.5         | -    | 2.4 | 0.5         | -    | 2.4 | 0.5         | -    | 2.4 | ns          |

Table 8. Clock and digital output timing characteristics<sup>[1]</sup> ...continued

| Symbol   | Parameter                | Conditions | ADC1015S065 |     |     | ADC1015S080 |     |     | ADC1015S105 |     |     | ADC1015S125 |     |     | Unit |
|--|--------------------------|------------|-------------|-----|-----|-------------|-----|-----|-------------|-----|-----|-------------|-----|-----|------|
|  |                          |            | Min         | Typ | Max | Min         | Typ | Max | Min         | Typ | Max | Min         | Typ | Max |      |
| <b>LVDS DDR mode timing output: pins D9P to D0P, D9M to D0M, DAVP and DAVM</b> |                          |            |             |     |     |             |     |     |             |     |     |             |     |     |      |
| t <sub>PD</sub>  | propagation delay        | DATA       | -           | 3.9 | -   | -           | 3.9 | -   | -           | 3.9 | -   | -           | 3.9 | -   | ns   |
|  |                          | DAV        | -           | 4.2 | -   | -           | 4.2 | -   | -           | 4.2 | -   | -           | 4.2 | -   | ns   |
| t <sub>su</sub>  | set-up time              |            | -           | 5.1 | -   | -           | 3.5 | -   | -           | 2.1 | -   | -           | 1.4 | -   | ns   |
| t <sub>h</sub>   | hold time                |            | -           | 2.0 | -   | -           | 2.0 | -   | -           | 2.0 | -   | -           | 2.0 | -   | ns   |
| t <sub>r</sub>   | rise time <sup>[3]</sup> | DATA       | 50          | 100 | 200 | 50          | 100 | 200 | 50          | 100 | 200 | 50          | 100 | 200 | ps   |
|  |                          | DAV        | 50          | 100 | 200 | 50          | 100 | 200 | 50          | 100 | 200 | 50          | 100 | 200 | ps   |
| t <sub>f</sub>   | fall time <sup>[3]</sup> | DATA       | 50          | 100 | 200 | 50          | 100 | 200 | 50          | 100 | 200 | 50          | 100 | 200 | ps   |

[1] Typical values measured at V<sub>DDA(3V)</sub> = 3 V, V<sub>DDO</sub> = 1.8 V, V<sub>DDA(5V)</sub> = 5 V; T<sub>amb</sub> = 25 °C and C<sub>L</sub> = 5 pF; minimum and maximum values are across the full temperature range T<sub>amb</sub> = -40 °C to +85 °C at V<sub>DDA(3V)</sub> = 3 V, V<sub>DDO</sub> = 1.8 V, V<sub>DDA(5V)</sub> = 5 V, V<sub>INP</sub> - V<sub>INM</sub> = -1 dBFS; internal reference mode; applied to CMOS and LVDS interface; unless otherwise specified.

[2] Measured between 20 % to 80 % of V<sub>DDO</sub>.

[3] Rise time measured from -50 mV to +50 mV; fall time measured from +50 mV to -50 mV.

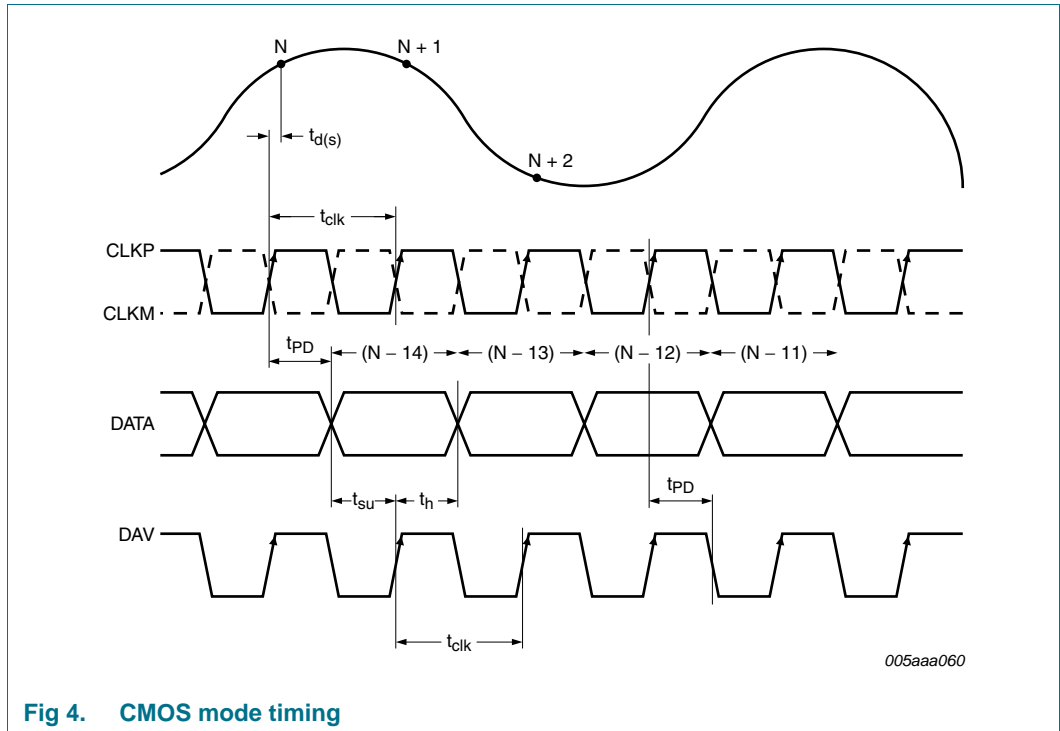

Fig 4. CMOS mode timing

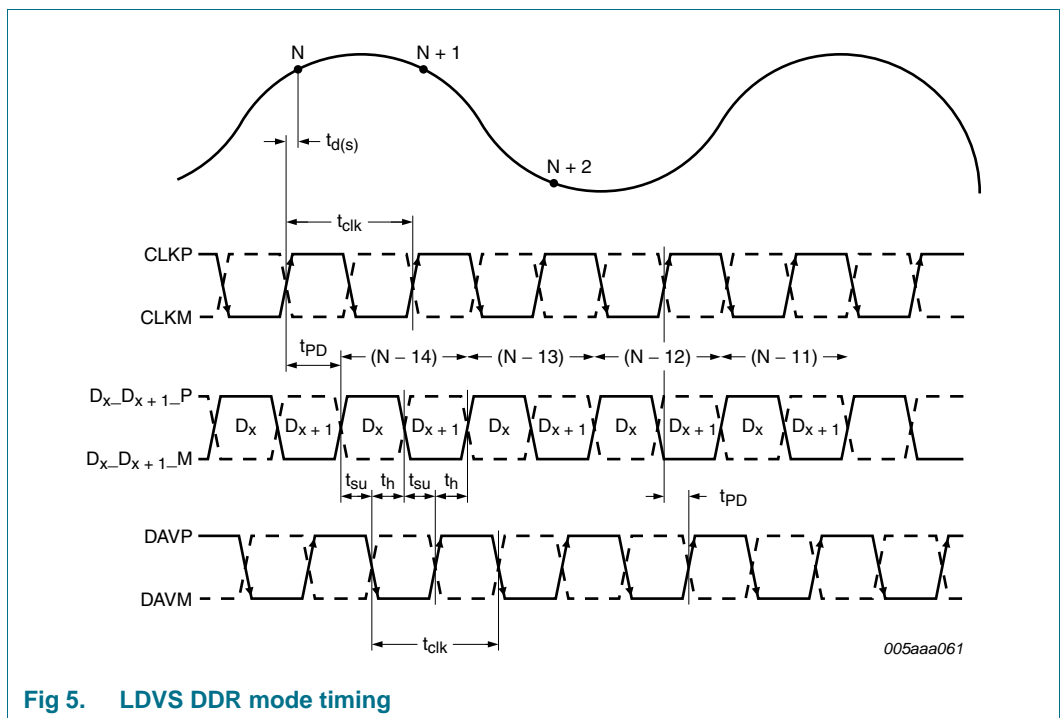

Fig 5. LVDS DDR mode timing

### 10.3 SPI timings

Table 9. Characteristics

| Symbol             | Parameter               | Conditions               | Min | Typ | Max | Unit |
|--------------------|-------------------------|--------------------------|-----|-----|-----|------|
| <b>SPI timings</b> |                         |                          |     |     |     |      |
| $t_{w(SCLK)}$      | SCLK pulse width        |                          | 40  | -   | -   | ns   |
| $t_{w(SCLKH)}$     | SCLK pulse width HIGH   |                          | 16  | -   | -   | ns   |
| $t_{w(SCLKL)}$     | SCLK pulse width LOW    |                          | 16  | -   | -   | ns   |
| $t_{su}$           | set-up time             | data to SCLKH            | 5   | -   | -   | ns   |
|                    |                         | $\overline{CS}$ to SCLKH | 5   | -   | -   | ns   |
| $t_h$              | hold time               | data to SCLKH            | 2   | -   | -   | ns   |
|                    |                         | $\overline{CS}$ to SCLKH | 2   | -   | -   | ns   |
| $f_{clk(max)}$     | maximum clock frequency |                          | -   | -   | 25  | MHz  |

[1] Typical values measured at  $V_{DDA(3V)} = 3\text{ V}$ ,  $V_{DDO} = 1.8\text{ V}$ ,  $V_{DDA(5V)} = 5\text{ V}$ ;  $T_{amb} = 25\text{ }^\circ\text{C}$  and  $C_L = 5\text{ pF}$ ; minimum and maximum values are across the full temperature range  $T_{amb} = -40\text{ }^\circ\text{C}$  to  $+85\text{ }^\circ\text{C}$  at  $V_{DDA(3V)} = 3\text{ V}$ ,  $V_{DDO} = 1.8\text{ V}$ ,  $V_{DDA(5V)} = 5\text{ V}$ ,  $V_{INP} - V_{INM} = -1\text{ dBFS}$ ; internal reference mode; applied to CMOS and LVDS interface; unless otherwise specified

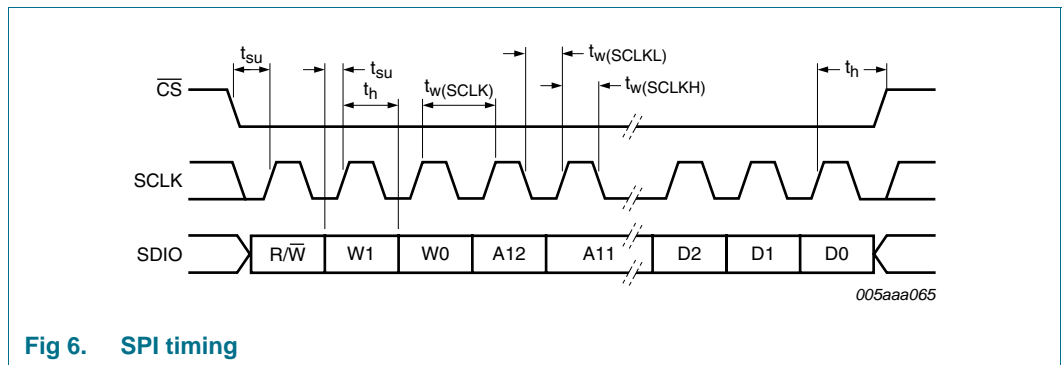

Fig 6. SPI timing

## 11. Application information

### 11.1 Device control

The ADC1015S can be controlled via the Serial Peripheral Interface (SPI) or directly via the I/O pins (Pin control mode).

#### 11.1.1 SPI and Pin control modes

The device enters Pin control mode at power-up, and remains in this mode as long as pin  $\overline{CS}$  is held HIGH. In Pin control mode, the SPI pins SDIO,  $\overline{CS}$  and SCLK are used as static control pins.

SPI control mode is enabled by forcing pin  $\overline{CS}$  LOW. Once SPI control mode has been enabled, the device will remain in this mode. The transition from Pin control mode to SPI control mode is illustrated in [Figure 7](#).

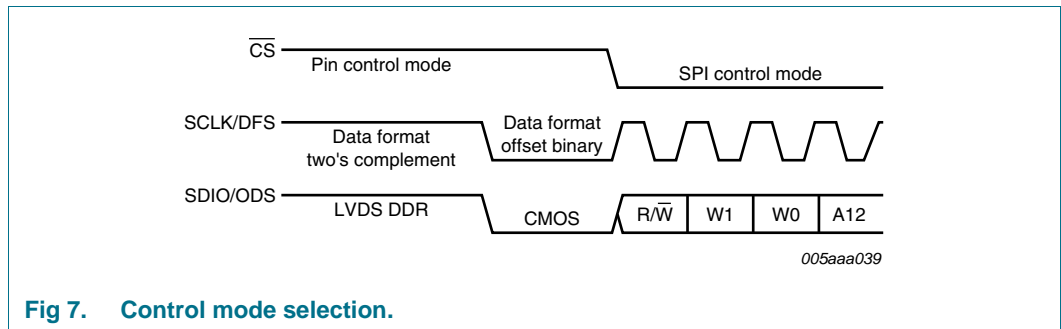

Fig 7. Control mode selection.

When the device enters SPI control mode, the output data standard and data format are determined by the level on pin SDIO as soon as a transition is triggered by a falling edge on  $\overline{CS}$ .

### 11.1.2 Operating mode selection

The active ADC1015S operating mode (Power-up, Power-down or Sleep) can be selected via the SPI interface (see [Table 19](#)) or using pins PWD and  $\overline{OE}$  in Pin control mode, as described in [Table 10](#).

Table 10. Operating mode selection via pin PWD and  $\overline{OE}$

| Pin PWD | Pin $\overline{OE}$ | Operating mode | Output high-Z |
|---------|---------------------|----------------|---------------|
| 0       | 0                   | Power-up       | no            |
| 0       | 1                   | Power-up       | yes           |
| 1       | 0                   | Sleep          | yes           |
| 1       | 1                   | Power-down     | yes           |

### 11.1.3 Selecting the output data standard

The output data standard (CMOS or LVDS DDR) can be selected via the SPI interface (see [Table 23](#)) or using pin ODS in Pin control mode. LVDS DDR is selected when ODS is HIGH, otherwise CMOS is selected.

### 11.1.4 Selecting the output data format

The output data format can be selected via the SPI interface (offset binary, two's complement or gray code; see [Table 23](#)) or using pin DFS in Pin control mode (offset binary or two's complement). Offset binary is selected when DFS is LOW. When DFS is HIGH, two's complement is selected.

## 11.2 Analog inputs

### 11.2.1 Input stage

The analog input of the ADC1015S supports differential or single-ended input drive. Optimal performance is achieved using differential inputs. The ADC inputs are internally biased and need to be decoupled.

The full scale analog input voltage range is configurable between 1 V (p-p) and 2 V (p-p) via a programmable internal reference (see [Section 11.3](#) and [Table 21](#) further details).



The equivalent circuit of the input buffer followed by the Sample and Hold (S/H) input stage, including ElectroStatic Discharge (ESD) protection and circuit and package parasitics, is shown in [Figure 8](#).

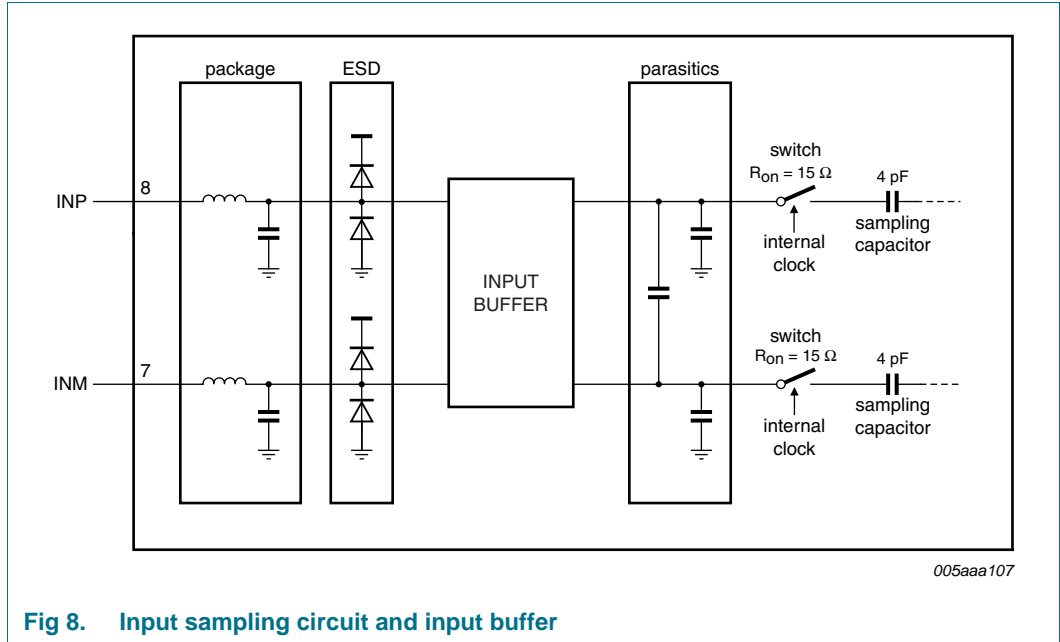

**Fig 8. Input sampling circuit and input buffer**

The integrated input buffer offers the following advantages:

- The kickback effect is avoided - the charge injection and glitches generated by the S/H input stage are isolated from the input circuitry. So there's no need for additional filtering.
- The input capacitance is very low and constant over a wide frequency range, which makes the ADC1015S easy to drive.

The sample phase occurs when the internal clock (derived from the clock signal on pin CLKP/CLKM) is HIGH. The voltage is then held on the sampling capacitors. When the clock signal goes LOW, the stage enters the hold phase and the voltage information is transmitted to the ADC core.

### 11.2.2 Transformer

The configuration of the transformer circuit is determined by the input frequency. The configuration shown in [Figure 9](#) would be suitable for a baseband application.

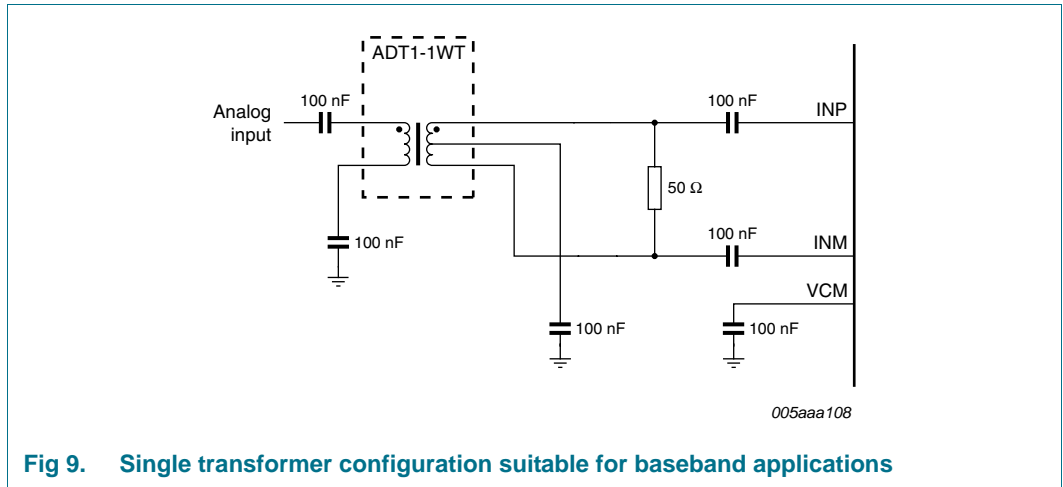

The configuration shown in [Figure 10](#) is recommended for high frequency applications. In both cases, the choice of transformer will be a compromise between cost and performance.

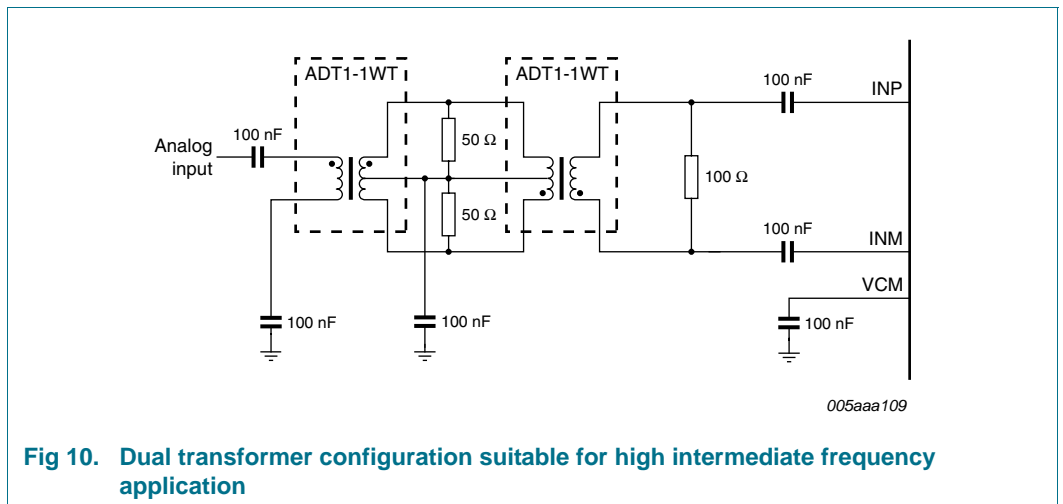

### 11.3 System reference and power management

#### 11.3.1 Internal/external references

The ADC1015S has a stable and accurate built-in internal reference voltage to adjust the ADC full-scale. This reference voltage can be set internally via SPI or with pins VREF and SENSE (programmable in 1 dB steps between 0 dB and -6 dB via control bits INTREF[2:0] when bit INTREF\_EN = 1; see [Table 21](#)). See [Figure 12](#), [Figure 13](#), [Figure 14](#) and [Figure 15](#). The equivalent reference circuit is shown in [Figure 11](#). External reference is also possible by providing a voltage on pin VREF as described in [Figure 14](#).

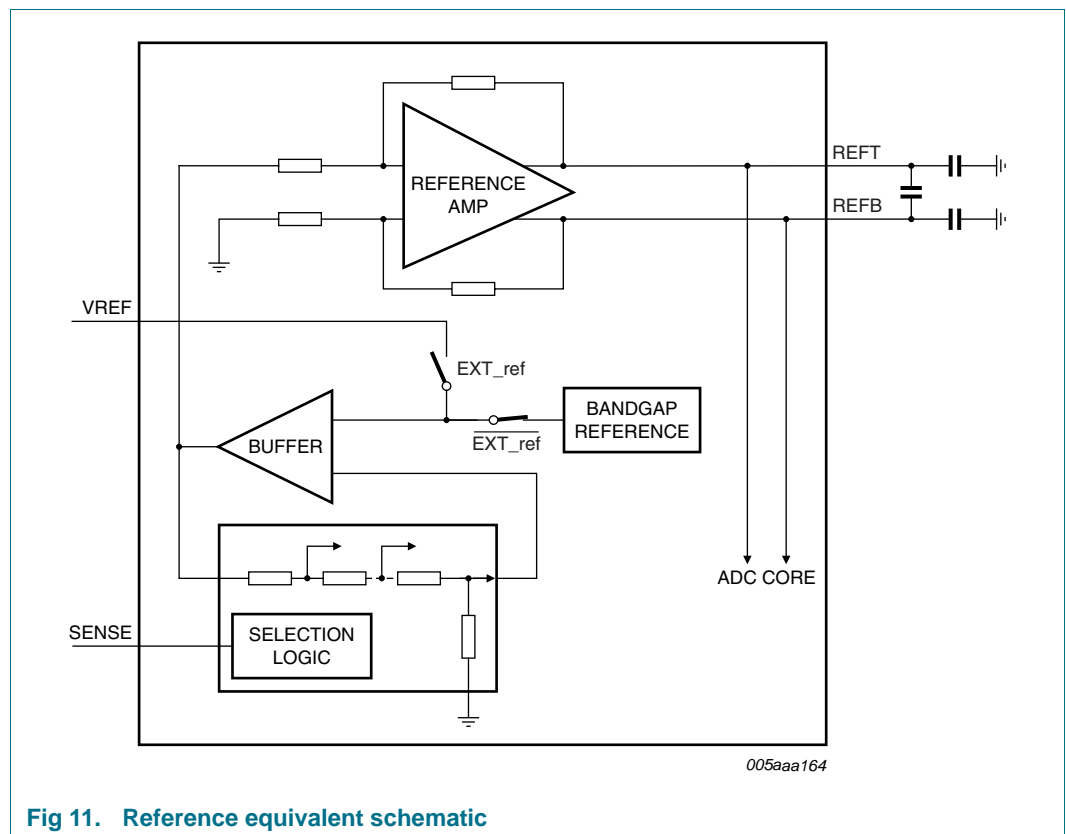

Fig 11. Reference equivalent schematic

If bit INTREF\_EN is set to 0, the reference voltage will be determined either internally or externally as detailed in [Table 11](#).

Table 11. Reference selection

| Selection   | SPI bit INTREF_EN | SENSE pin  | VREF pin  | full scale (p-p) |
|---|-------------------|--|---|------------------|
| internal<br>( <a href="#">Figure 12</a> )         | 0                 | AGND   | 330 pF capacitor to AGND                              | 2 V              |
| internal<br>( <a href="#">Figure 13</a> )         | 0                 | pin VREF connected to pin SENSE and via a 330 pF capacitor to AGND |   | 1 V              |
| external<br>( <a href="#">Figure 14</a> )         | 0                 | V <sub>DDA(3V)</sub>   | external voltage between 0.5 V and 1 V <sup>[1]</sup> | 1 V to 2 V       |
| internal via SPI<br>( <a href="#">Figure 15</a> ) | 1                 | pin VREF connected to pin SENSE and via 330 pF capacitor to AGND   |   | 1 V to 2 V       |

[1] The voltage on pin VREF is doubled internally to generate the internal reference voltage.

Figure 12 to Figure 15 illustrate how to connect the SENSE and VREF pins to select the required reference voltage source.

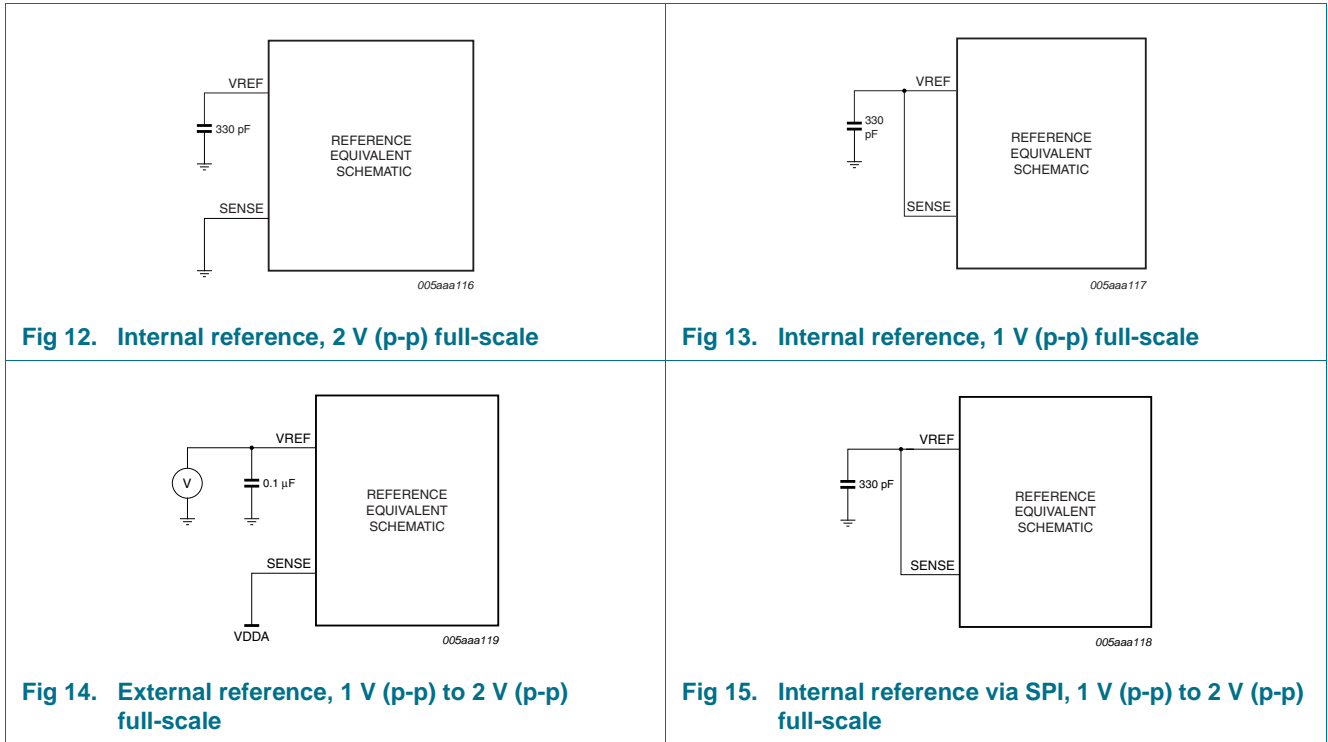

### 11.3.2 Reference gain control

The reference gain is programmable between 0 dB to -6 dB in 1 dB steps via the SPI (see Table 21). The corresponding full-scale input voltage range varies between 2 V (p-p) and 1 V (p-p), as shown in Table 12:

Table 12. Reference SPI Gain Control

| INTREF | Gain     | full scale (p-p) |
|--------|----------|------------------|
| 000    | 0 dB     | 2 V              |
| 001    | -1 dB    | 1.78 V           |
| 010    | -2 dB    | 1.59 V           |
| 011    | -3 dB    | 1.42 V           |
| 100    | -4 dB    | 1.26 V           |
| 101    | -5 dB    | 1.12 V           |
| 110    | -6 dB    | 1 V              |
| 111    | reserved | x                |

### 11.3.3 Common-mode output voltage (V<sub>O(cm)</sub>)

A 0.1 μF filter capacitor should be connected between pin VCM and ground.

### 11.3.4 Biasing

The common-mode input voltage (V<sub>I(cm)</sub>) on pins INP and INM is set internally. The input buffer bias current can be set to one of three levels (high, medium or low) via the SPI (see Table 22).

11.4 Clock input

11.4.1 Drive modes

The ADC1015S can be driven differentially (SINE, LVPECL or LVDS) with little or no degradation on dynamic performances. It can also be driven by a single-ended LVCMOS signal connected to pin CLKP (CLKM should be connected to ground via a capacitor) or CLKM (CLKP should be connected to ground via a capacitor).

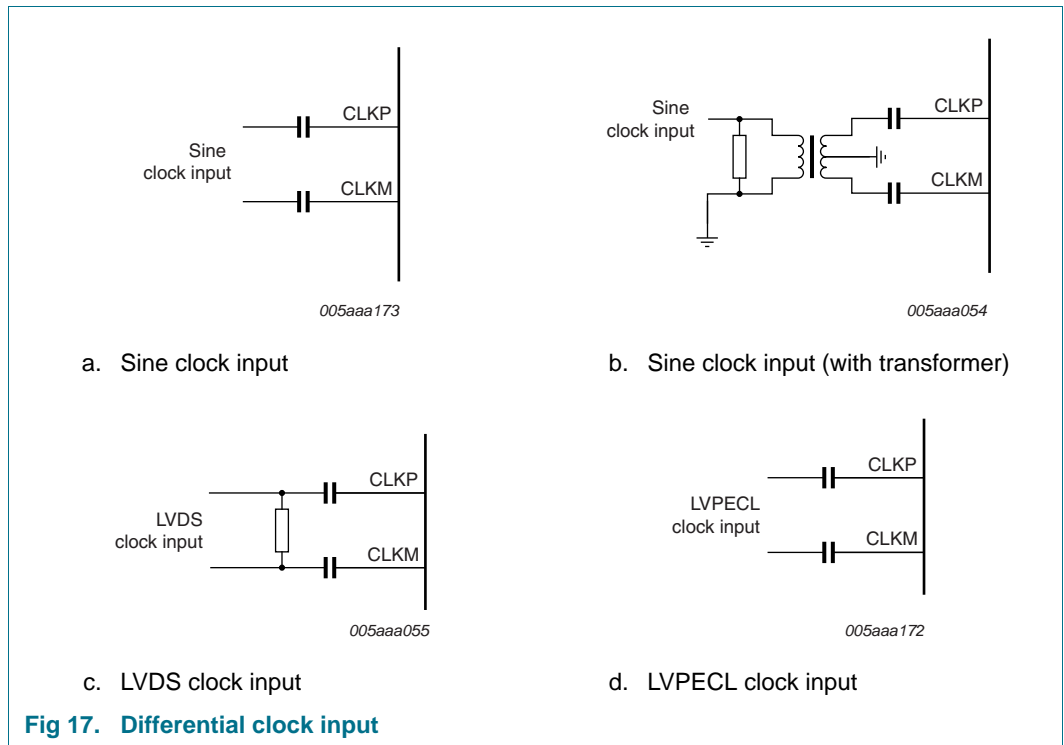
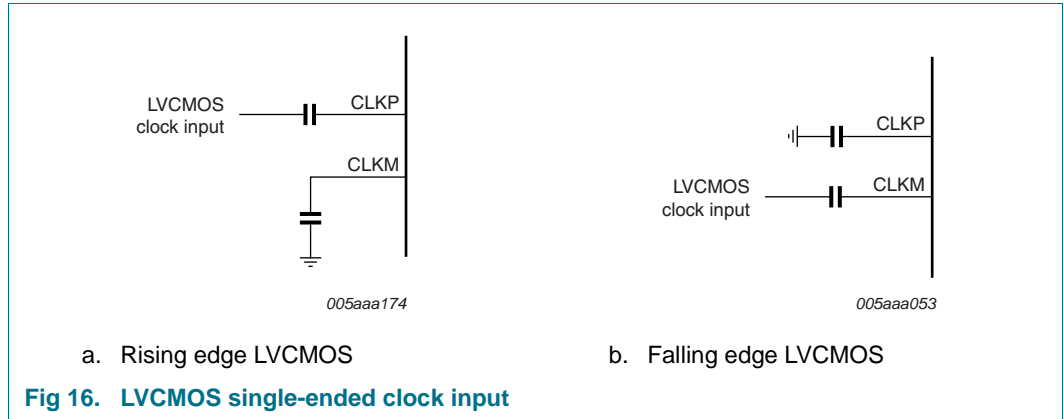

11.4.2 Equivalent input circuit

The equivalent circuit of the input clock buffer is shown in Figure 18. The common-mode voltage of the differential input stage is set via internal 5 kΩ resistors.

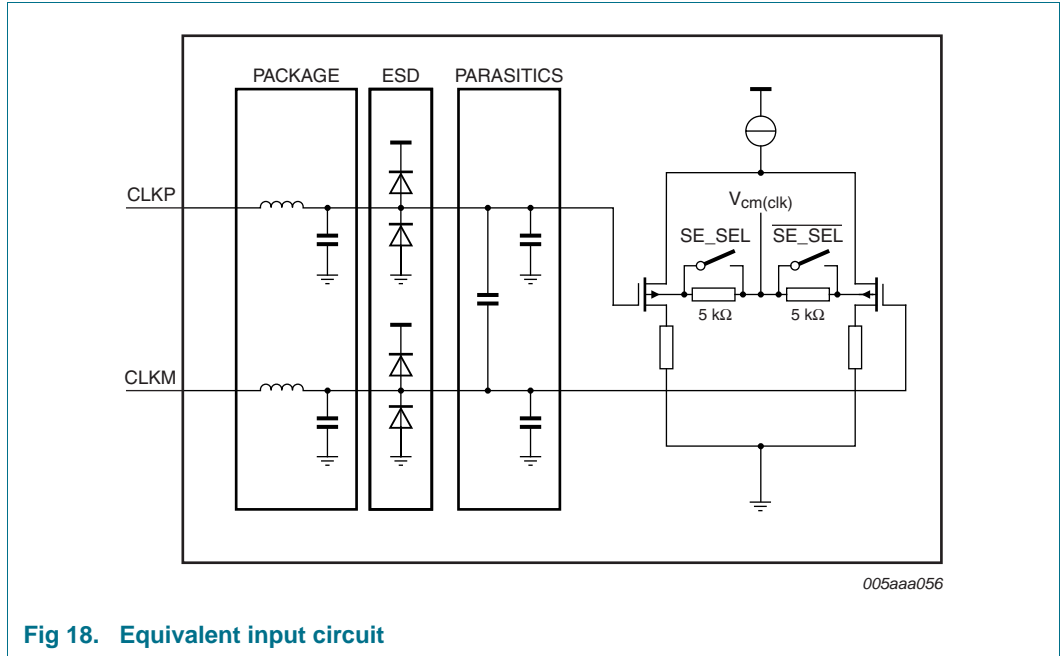

Fig 18. Equivalent input circuit

Single-ended or differential clock inputs can be selected via the SPI interface (see Table 20). If single-ended is enabled, the input pin (CLKM or CLKP) is selected via control bit SE\_SEL.

If single-ended is implemented without setting SE\_SEL to the appropriate value, the unused pin should be connected to ground via a capacitor.

11.4.3 Duty cycle stabilizer

The duty cycle stabilizer can improve the overall performances of the ADC by compensating the duty cycle of the input clock signal. When the duty cycle stabilizer is active (bit DCS\_EN = 1; see Table 20), the circuit can handle signals with duty cycles of between 30 % and 70 % (typical). When the duty cycle stabilizer is disabled (DCS\_EN = 0), the input clock signal should have a duty cycle of between 45% and 55%.

11.4.4 Clock input divider

The ADC1015S contains an input clock divider that divides the incoming clock by a factor of 2 (when bit CLKDIV = 1; see Table 20). This feature allows the user to deliver a higher clock frequency with better jitter performance, leading to a better SNR result once acquisition has been performed.

## 11.5 Digital outputs

### 11.5.1 Digital output buffers: CMOS mode

The digital output buffers can be configured as CMOS by setting bit LVDS/CMOS to 0 (see [Table 23](#)).

Each digital output has a dedicated output buffer. The equivalent circuit of the CMOS digital output buffer is shown in [Figure 19](#). The buffer is powered by a separate OGND/V<sub>DDO</sub> to ensure 1.8 V to 3.3 V compatibility and is isolated from the ADC core. Each buffer can be loaded by a maximum of 10 pF.

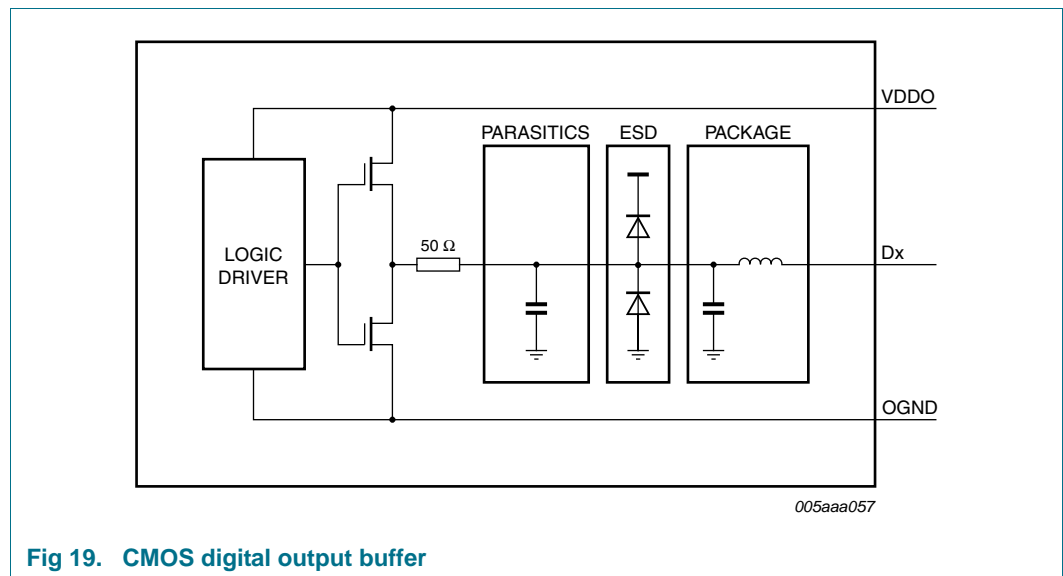

Fig 19. CMOS digital output buffer

The output resistance is 50 Ω and is the combination of the an internal resistor and the equivalent output resistance of the buffer. There is no need for an external damping resistor. The drive strength of both data and DAV buffers can be programmed via the SPI in order to adjust the rise and fall times of the output digital signals (see [Table 30](#)):

11.5.2 Digital output buffers: LVDS DDR mode

The digital output buffers can be configured as LVDS DDR by setting bit LVDS/CMOS to 1 (see Table 23).

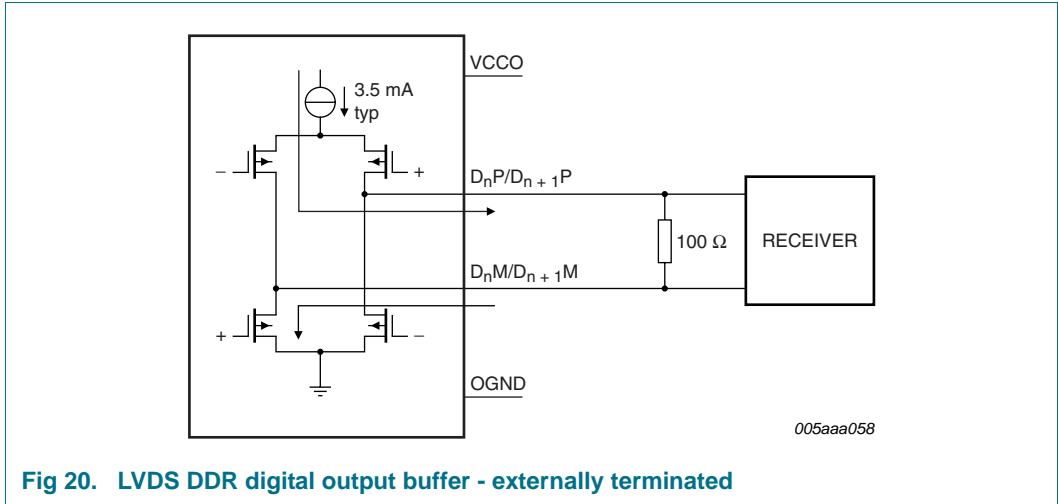

Fig 20. LVDS DDR digital output buffer - externally terminated

Each output should be terminated externally with a 100 Ω resistor (typical) at the receiver side (Figure 20) or internally via SPI control bits LVDS\_INT\_TER[2:0] (see Figure 21 and Table 32).

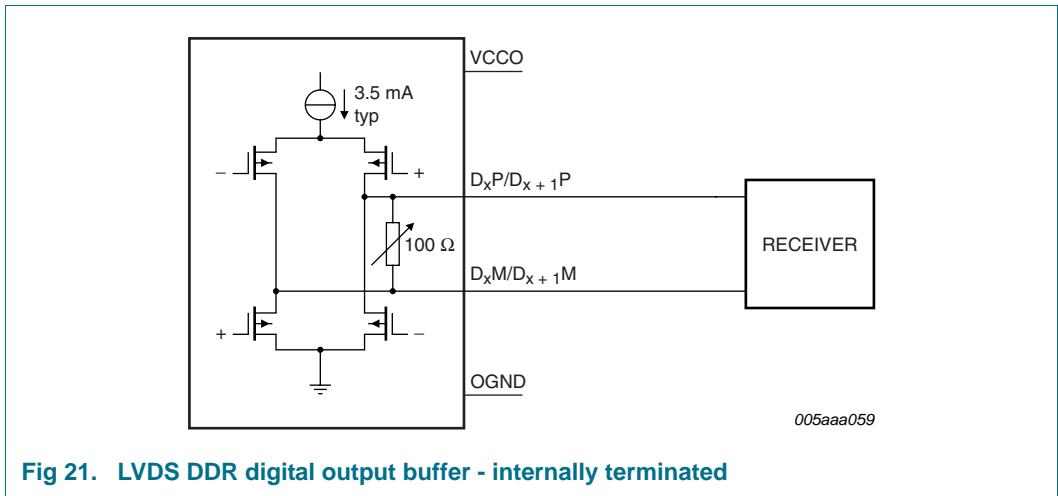

Fig 21. LVDS DDR digital output buffer - internally terminated

The default LVDS DDR output buffer current is set to 3.5 mA. It can be programmed via the SPI (bits DAVI[1:0] and DATAI[1:0]; see Table 31) in order to adjust the output logic voltage levels.

Table 13. LVDS DDR output register 2

| LVDS_INT_TER[2:0] | Resistor value (Ω)      |
|-------------------|-------------------------|
| 000               | no internal termination |
| 001               | 300                     |
| 010               | 180                     |
| 011               | 110                     |
| 100               | 150                     |



Table 13. LVDS DDR output register 2 ...continued

| LVDS_INT_TER[2:0] | Resistor value ( $\Omega$ ) |
|-------------------|-----------------------------|
| 101               | 100                         |
| 110               | 81                          |
| 111               | 60                          |

### 11.5.3 Data valid (DAV) output clock

A data valid output clock signal (DAV) is provided that can be used to capture the data delivered by the ADC1015S. Detailed timing diagrams for CMOS and LVDS DDR modes are provided in [Figure 4](#) and [Figure 5](#) respectively.

### 11.5.4 Out-of-Range (OTR)

An out-of-range signal is provided on pin OTR. The latency of OTR is fourteen clock cycles. The OTR response can be speeded up by enabling Fast OTR (bit FASTOTR = 1; see [Table 29](#)). In this mode, the latency of OTR is reduced to only four clock cycles. The Fast OTR detection threshold (below full scale) can be programmed via bits FASTOTR\_DET[2:0].

Table 14. Fast OTR register

| FASTOTR_DET[2:0] | Detection level (dB) |
|------------------|----------------------|
| 000              | -20.56               |
| 001              | -16.12               |
| 010              | -11.02               |
| 011              | -7.82                |
| 100              | -5.49                |
| 101              | -3.66                |
| 110              | -2.14                |
| 111              | -0.86                |

### 11.5.5 Digital offset

By default, the ADC1015S delivers output code that corresponds to the analog input. However it is possible to add a digital offset to the output code via the SPI (bits DIG\_OFFSET[5:0]; see [Table 25](#)).

### 11.5.6 Test patterns

For test purposes, the ADC1015S can be configured to transmit one of a number of predefined test patterns (via bits TESTPAT\_SEL[2:0]; see [Table 26](#)). A custom test pattern can be defined by the user (TESTPAT\_USER; see [Table 27](#) and [Table 28](#)) and is selected when TESTPAT\_SEL[2:0] = 101. The selected test pattern will be transmitted regardless of the analog input.

## 11.5.7 Output codes versus input voltage

Table 15. Output codes

| $V_{INP} - V_{INM}$ | Offset binary       | Two's complement    | OTR pin |
|---------------------|---------------------|---------------------|---------|
| < -1                | 00 0000 0000        | 10 0000 0000        | 1       |
| -1.0000000          | 00 0000 0000        | 10 0000 0000        | 0       |
| -0.9980469          | 00 0000 0001        | 10 0000 0001        | 0       |
| -0.9960938          | 00 0000 0010        | 10 0000 0010        | 0       |
| -0.9941406          | 00 0000 0011        | 10 0000 0011        | 0       |
| -0.9921875          | 00 0000 0100        | 10 0000 0100        | 0       |
| ....                | ....                | ....                | 0       |
| -0.0039063          | 01 1111 1110        | 11 1111 1110        | 0       |
| -0.0019531          | 01 1111 1111        | 11 1111 1111        | 0       |
| 0.0000000           | <b>10 0000 0000</b> | <b>00 0000 0000</b> | 0       |
| +0.0019531          | 10 0000 0001        | 00 0000 0001        | 0       |
| +0.0039063          | 10 0000 0010        | 00 0000 0010        | 0       |
| ....                | ....                | ....                | 0       |
| +0.9921875          | 11 1111 1011        | 01 1111 1011        | 0       |
| +0.9941406          | 11 1111 1100        | 01 1111 1100        | 0       |
| +0.9960938          | 11 1111 1101        | 01 1111 1101        | 0       |
| +0.9980469          | 11 1111 1110        | 01 1111 1110        | 0       |
| +1.0000000          | 11 1111 1111        | 01 1111 1111        | 0       |
| > +1                | 11 1111 1111        | 01 1111 1111        | 1       |

## 11.6 Serial peripheral interface

### 11.6.1 Register description

The ADC1015S serial interface is a synchronous serial communications port that allows for easy interfacing with many commonly-used microprocessors. It provides access to the registers that control the operation of the chip.

This interface is configured as a 3-wire type (SDIO as bidirectional pin)

Pin SCLK is the serial clock input and  $\overline{CS}$  is the chip select pin.

Each read/write operation is initiated by a LOW level on CS. A minimum of three bytes will be transmitted (two instruction bytes and at least one data byte). The number of data bytes is determined by the value of bits W1 and W2 (see [Table 17](#)).

Table 16. Instruction bytes for the SPI

|             | MSB                  |       |       |     |     |     |    | LSB |
|-------------|----------------------|-------|-------|-----|-----|-----|----|-----|
| Bit         | 7                    | 6     | 5     | 4   | 3   | 2   | 1  | 0   |
| Description | $R/\overline{W}$ [1] | W1[2] | W0[2] | A12 | A11 | A10 | A9 | A8  |
|             | A7                   | A6    | A5    | A4  | A3  | A2  | A1 | A0  |

[1] Bit  $R/\overline{W}$  indicates whether it is a read (1) or a write (0) operation.

[2] Bits W1 and W0 indicate the number of bytes to be transferred after the instruction byte (see [Table 17](#)).

**Table 17. Number of data bytes to be transferred after the instruction bytes**

| W1 | W0 | Number of bytes transmitted |
|----|----|-----------------------------|
| 0  | 0  | 1 byte                      |
| 0  | 1  | 2 bytes                     |
| 1  | 0  | 3 bytes                     |
| 1  | 1  | 4 bytes or more             |

Bits A12 to A0 indicate the address of the register being accessed. In the case of a multiple byte transfer, this address is the first register to be accessed. An address counter is increased to access subsequent addresses.

The steps involved in a data transfer are as follows:

1. A falling edge on  $\overline{CS}$  in combination with a rising edge on SCLK determine the start of communications.
2. The first phase is the transfer of the 2-byte instruction.
3. The second phase is the transfer of the data which can vary in length but will always be a multiple of 8 bits. The MSB is always sent first (for instruction and data bytes).
4. A rising edge on  $\overline{CS}$  indicates the end on data transmission.

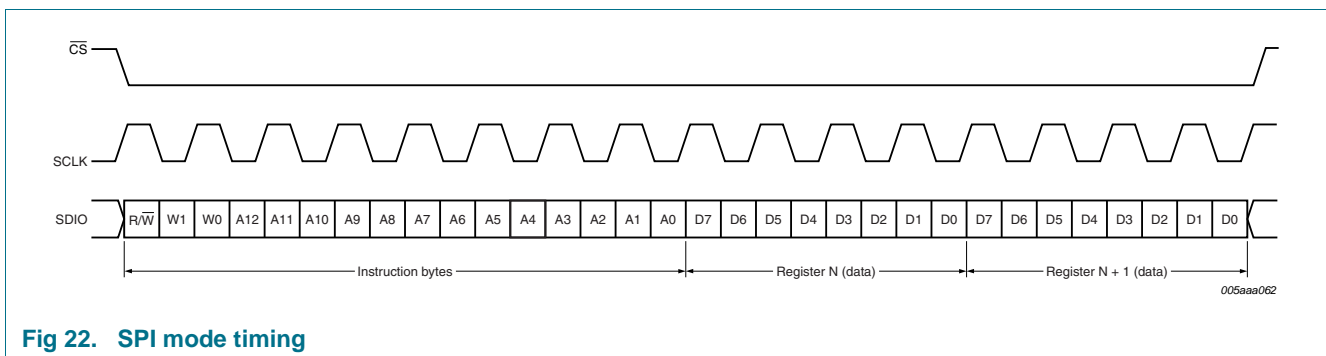

**Fig 22. SPI mode timing**

### 11.6.2 Default modes at start-up

During circuit initialization, it does not matter which output data standard has been selected. At power-up, the device enters Pin control mode.

A falling edge on  $\overline{CS}$  will trigger a transition to SPI control mode. When the ADC1015S enters SPI control mode, the output data standard (CMOS/LVDS DDR) is determined by the level on pin SDIO (see [Figure 23](#)). Once in SPI control mode, the output data standard can be changed via bit LVDS/CMOS in [Table 23](#).

When the ADC1015S enters SPI control mode, the output data format (two's complement or offset binary) is determined by the level on pin SCLK (gray code can only be selected via the SPI). Once in SPI control mode, the output data format can be changed via bit DATA\_FORMAT[1:0] in [Table 23](#).

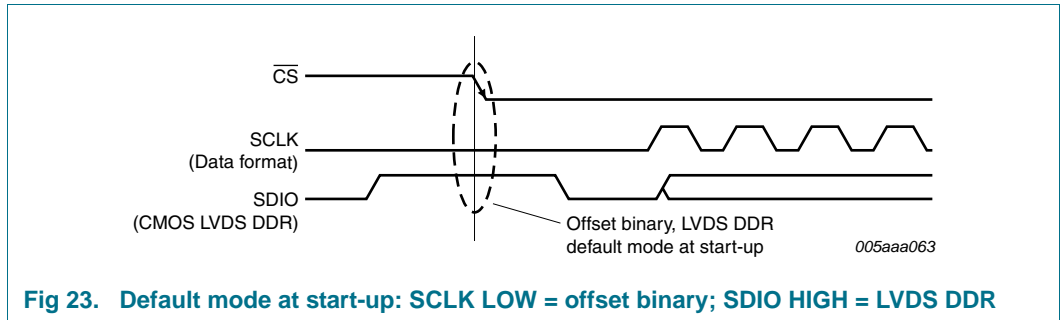

Fig 23. Default mode at start-up: SCLK LOW = offset binary; SDIO HIGH = LVDS DDR

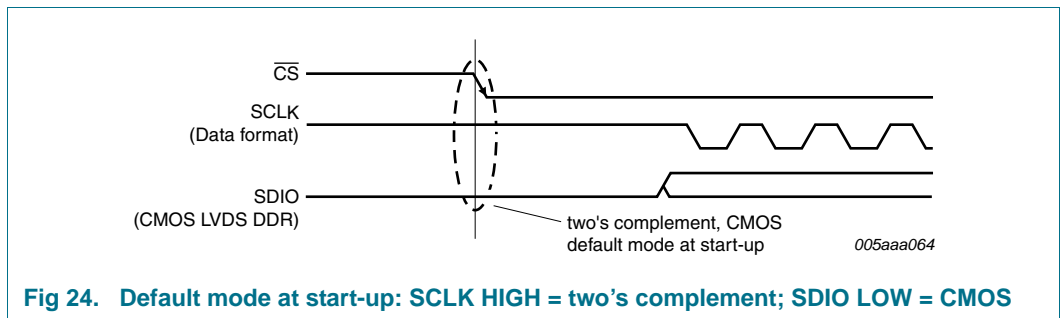

Fig 24. Default mode at start-up: SCLK HIGH = two's complement; SDIO LOW = CMOS

## 11.6.3 Register allocation map

Table 18. Register allocation map

| AddrHex | Register name            | R/W | Bit definition    |               |                 |           |               |                   |                  |        | Default Bin  |              |
|---------|--------------------------|-----|-------------------|---------------|-----------------|-----------|---------------|-------------------|------------------|--------|--------------|--------------|
|         |                          |     | Bit 7             | Bit 6         | Bit 5           | Bit 4     | Bit 3         | Bit 2             | Bit 1            | Bit 0  |              |              |
| 0005    | Reset and operating mode | R/W | SW_RST            | RESERVED[2:0] |                 |           | -             | -                 | OP_MODE[1:0]     |        | 0000<br>0000 |              |
| 0006    | Clock                    | R/W | -                 | -             | -               | SE_SEL    | DIFF_SE       | -                 | CLKDIV           | DCS_EN | 0000<br>0001 |              |
| 0008    | Internal reference       | R/W | -                 | -             | -               | -         | INTREF_EN     | INTREF[2:0]       |                  |        | 0000<br>0000 |              |
| 0010    | Input buffer             | R/W | -                 | -             | -               | -         | -             | -                 | IB_IBIAS[1:0]    | -      | 0000<br>0011 |              |
| 0011    | Output data standard.    | R/W | -                 | -             | -               | LVDS_CMOS | OUTBUF        | OUTBUS_SWAP       | DATA_FORMAT[1:0] |        | 0000<br>0000 |              |
| 0012    | Output clock             | R/W | -                 | -             | -               | -         | DAVINV        | DAVPHASE[2:0]     |                  |        | 0000<br>1110 |              |
| 0013    | Offset                   | R/W | -                 | -             | DIG_OFFSET[5:0] |           |               |                   |                  |        | 0000<br>0000 |              |
| 0014    | Test pattern 1           | R/W | -                 | -             | -               | -         | -             | TESTPAT_SEL[2:0]  |                  |        | 0000<br>0000 |              |
| 0015    | Test pattern 2           | R/W | TESTPAT_USER[9:2] |               |                 |           |               |                   |                  |        |              | 0000<br>0000 |
| 0016    | Test pattern 3           | R/W | TESTPAT_USER[1:0] | -             | -               | -         | -             | -                 | -                | -      | 0000<br>0000 |              |
| 0017    | Fast OTR                 | R/W | -                 | -             | -               | -         | FASTOTR       | FASTOTR_DET[2:0]  |                  |        | 0000<br>0000 |              |
| 0020    | CMOS output              | R/W | -                 | -             | -               | -         | DAV_DRV[1:0]  |                   | DATA_DRV[1:0]    |        | 0000<br>1110 |              |
| 0021    | LVDS DDR O/P 1           | R/W | -                 | -             | DAVI_x2_EN      | DAVI[1:0] |               | DATAI_x2_EN       | DATAI[1:0]       |        | 0000<br>0000 |              |
| 0022    | LVDS DDR O/P 2           | R/W | -                 | -             | -               | -         | BIT_BYTE_WISE | LVDS_INT_TER[2:0] |                  |        | 0000<br>0000 |              |

Table 19. Reset and operating mode control register (address 0005h) bit description

| Bit    | Symbol        | Access | Value | Description                       |
|--------|---------------|--------|-------|-----------------------------------|
| 7      | SW_RST        | R/W    |       | reset digital section             |
|        |               |        | 0     | no reset                          |
|        |               |        | 1     | performs a reset on SPI registers |
| 6 to 4 | RESERVED[2:0] |        | 000   | reserved                          |
| 3 to 2 | -             |        | 00    | not used                          |
| 1 to 0 | OP_MODE[1:0]  | R/W    |       | operating mode                    |
|        |               |        | 00    | normal (Power-up)                 |
|        |               |        | 01    | Power-down                        |
|        |               |        | 10    | Sleep                             |
|        |               |        | 11    | normal (Power-up)                 |

Table 20. Clock control register (address 0006h) bit description

| Bit    | Symbol  | Access | Value | Description                                  |
|--------|---------|--------|-------|--|
| 7 to 5 | -       |        | 000   | not used                                     |
| 4      | SE_SEL  | R/W    |       | single-ended clock input pin select          |
|        |         |        | 0     | CLKM   |
|        |         |        | 1     | CLKP   |
| 3      | DIFF_SE | R/W    |       | differential/single ended clock input select |
|        |         |        | 0     | fully differential                           |
|        |         |        | 1     | single-ended                                 |
| 2      | -       |        | 0     | not used                                     |
| 1      | CLKDIV  | R/W    |       | clock input divide by 2                      |
|        |         |        | 0     | disabled                                     |
|        |         |        | 1     | enabled                                      |
| 0      | DCS_EN  | R/W    |       | duty cycle stabilizer                        |
|        |         |        | 0     | disabled                                     |
|        |         |        | 1     | enabled                                      |

Table 21. Internal reference control register (address 0008h) bit description

| Bit    | Symbol      | Access | Value | Description                            |
|--------|-------------|--------|-------|--|
| 7 to 4 | -           |        | 0000  | not used                               |
| 3      | INTREF_EN   | R/W    |       | programmable internal reference enable |
|        |             |        | 0     | disable                                |
|        |             |        | 1     | active                                 |
| 2 to 0 | INTREF[2:0] | R/W    |       | programmable internal reference        |
|        |             |        | 000   | 0 dB (FS = 2 V)                        |
|        |             |        | 001   | -1 dB (FS = 1.78 V)                    |
|        |             |        | 010   | -2 dB (FS = 1.59 V)                    |
|        |             |        | 011   | -3 dB (FS = 1.42 V)                    |
|        |             |        | 100   | -4 dB (FS = 1.26 V)                    |
|        |             |        | 101   | -5 dB (FS = 1.12 V)                    |
|        |             |        | 110   | -6 dB (FS = 1 V)                       |
|        |             |        | 111   | reserved                               |

Table 22. Input buffer control register (address 0010h) bit description

| Bit    | Symbol        | Access | Value  | Description               |
|--------|---------------|--------|--------|---------------------------|
| 7 to 2 | -             |        | 000000 | not used                  |
| 1 to 0 | IB_IBIAS[1:0] | R/W    |        | input buffer bias current |
|        |               |        | 00     | not used                  |
|        |               |        | 01     | medium                    |
|        |               |        | 10     | low                       |
|        |               |        | 11     | high                      |

Table 23. Output data standard control register (address 0011h) bit description

| Bit    | Symbol           | Access | Value | Description  |
|--------|------------------|--------|-------|--|
| 7 to 5 | -                |        | 000   | not used   |
| 4      | LVDS_CMOS        | R/W    |       | output data standard: LVDS DDR or CMOS                 |
|        |                  |        | 0     | CMOS   |
|        |                  |        | 1     | LVDS DDR   |
| 3      | OUTBUF           | R/W    |       | output buffers enable                                  |
|        |                  |        | 0     | output enabled   |
|        |                  |        | 1     | output disabled (high Z)                               |
| 2      | OUTBUS_SWAP      | R/W    |       | output bus swapping                                    |
|        |                  |        | 0     | no swapping  |
|        |                  |        | 1     | output bus is swapped (MSB becomes LSB and vice versa) |
| 1 to 0 | DATA_FORMAT[1:0] | R/W    |       | output data format                                     |
|        |                  |        | 00    | offset binary  |
|        |                  |        | 01    | two's complement                                       |
|        |                  |        | 10    | gray code  |
|        |                  |        | 11    | offset binary  |

Table 24. Output clock register (address 0012h) bit description

| Bit    | Symbol        | Access | Value | Description                                |
|--------|---------------|--------|-------|--|
| 7 to 4 | -             |        | 0000  | not used                                   |
| 3      | DAVINV        | R/W    |       | output clock data valid (DAV) polarity     |
|        |               |        | 0     | normal                                     |
|        |               |        | 1     | inverted                                   |
| 2 to 0 | DAVPHASE[2:0] | R/W    |       | DAV phase select                           |
|        |               |        | 000   | output clock shifted (ahead) by 3 ns       |
|        |               |        | 001   | output clock shifted (ahead) by 2.5 ns     |
|        |               |        | 010   | output clock shifted (ahead) by 2 ns       |
|        |               |        | 011   | output clock shifted (ahead) by 1.5 ns     |
|        |               |        | 100   | output clock shifted (ahead) by 1 ns       |
|        |               |        | 101   | output clock shifted (ahead) by 0.5 ns     |
|        |               |        | 110   | default value as defined in timing section |
|        |               |        | 111   | output clock shifted (delayed) by 0.5 ns   |

Table 25. Offset register (address 0013h) bit description

| Bit    | Symbol          | Access | Value  | Description               |
|--------|-----------------|--------|--------|---------------------------|
| 7 to 6 | -               |        | 00     | not used                  |
| 5 to 0 | DIG_OFFSET[5:0] | R/W    |        | digital offset adjustment |
|        |                 |        | 011111 | +31 LSB                   |
|        |                 |        | ...    | ...                       |
|        |                 |        | 000000 | 0                         |
|        |                 |        | ...    | ...                       |
|        |                 |        | 100000 | -32 LSB                   |

Table 26. Test pattern register 1 (address 0014h) bit description

| Bit    | Symbol           | Access | Value | Description                      |
|--------|------------------|--------|-------|----------------------------------|
| 7 to 3 | -                |        | 00000 | not used                         |
| 2 to 0 | TESTPAT_SEL[2:0] | R/W    |       | digital test pattern select      |
|        |                  |        | 000   | off                              |
|        |                  |        | 001   | mid scale                        |
|        |                  |        | 010   | -FS                              |
|        |                  |        | 011   | +FS                              |
|        |                  |        | 100   | toggle '1111..1111'/'0000..0000' |
|        |                  |        | 101   | custom test pattern              |
|        |                  |        | 110   | '1010..1010.'                    |
|        |                  |        | 111   | '010..1010'                      |

Table 27. Test pattern register 2 (address 0015h) bit description

| Bit    | Symbol            | Access | Value    | Description                               |
|--------|-------------------|--------|----------|---|
| 7 to 0 | TESTPAT_USER[9:2] | R/W    | 00000000 | custom digital test pattern (bits 9 to 2) |



Table 28. Test pattern register 3 (address 0016h) bit description

| Bit    | Symbol            | Access | Value  | Description                               |
|--------|-------------------|--------|--------|---|
| 7 to 6 | TESTPAT_USER[1:0] | R/W    | 00     | custom digital test pattern (bits 1 to 0) |
| 5 to 0 | -                 |        | 000000 | not used                                  |

Table 29. Fast OTR register (address 0017h) bit description

| Bit    | Symbol           | Access | Value | Description                       |
|--------|------------------|--------|-------|-----------------------------------|
| 7 to 4 | -                |        | 0000  | not used                          |
| 3      | FASTOTR          | R/W    |       | fast Out-of-Range (OTR) detection |
|        |                  |        | 0     | disabled                          |
|        |                  |        | 1     | enabled                           |
| 2 to 0 | FASTOTR_DET[2:0] | R/W    |       | set fast OTR detect level         |
|        |                  |        | 000   | -20.56 dB                         |
|        |                  |        | 001   | -16.12 dB                         |
|        |                  |        | 010   | -11.02 dB                         |
|        |                  |        | 011   | -7.82 dB                          |
|        |                  |        | 100   | -5.49 dB                          |
|        |                  |        | 101   | -3.66 dB                          |
|        |                  |        | 110   | -2.14 dB                          |
|        |                  |        | 111   | -0.86 dB                          |

Table 30. CMOS output register (address 0020h) bit description

| Bit    | Symbol        | Access | Value | Description                                |
|--------|---------------|--------|-------|--|
| 7 to 4 | -             |        | 0000  | not used                                   |
| 3 to 2 | DAV_DRV[1:0]  | R/W    |       | drive strength for DAV CMOS output buffer  |
|        |               |        | 00    | low  |
|        |               |        | 01    | medium                                     |
|        |               |        | 10    | high                                       |
|        |               |        | 11    | very high                                  |
| 1 to 0 | DATA_DRV[1:0] | R/W    |       | drive strength for DATA CMOS output buffer |
|        |               |        | 00    | low  |
|        |               |        | 01    | medium                                     |
|        |               |        | 10    | high                                       |
|        |               |        | 11    | very high                                  |

Table 31. LVDS DDR output register 1 (address 0021h) bit description

| Bit    | Symbol      | Access | Value | Description                              |
|--------|-------------|--------|-------|--|
| 7 to 6 | -           |        | 00    | not used                                 |
| 5      | DAVI_x2_EN  | R/W    |       | double LVDS current for DAV LVDS buffer  |
|        |             |        | 0     | disabled                                 |
|        |             |        | 1     | enabled                                  |
| 4 to 3 | DAVI[1:0]   | R/W    |       | LVDS current for DAV LVDS buffer         |
|        |             |        | 00    | 3.5 mA                                   |
|        |             |        | 01    | 4.5 mA                                   |
|        |             |        | 10    | 1.25 mA                                  |
|        |             |        | 11    | 2.5 mA                                   |
| 2      | DATAI_x2_EN | R/W    |       | double LVDS current for DATA LVDS buffer |
|        |             |        | 0     | disabled                                 |
|        |             |        | 1     | enabled                                  |
| 1 to 0 | DATAI[1:0]  | R/W    |       | LVDS current for DATA LVDS buffer        |
|        |             |        | 00    | 3.5 mA                                   |
|        |             |        | 01    | 4.5 mA                                   |
|        |             |        | 10    | 1.25 mA                                  |
|        |             |        | 11    | 2.5 mA                                   |

Table 32. LVDS DDR output register 2 (address 0022h) bit description

| Bit    | Symbol           | Access | Value | Description  |
|--------|------------------|--------|-------|--|
| 7 to 4 | -                |        | 0000  | not used   |
| 3      | BIT/BYTE_WISE    | R/W    |       | DDR mode for LVDS output   |
|        |                  |        | 0     | bit wise (even data bits output on DAV rising edge / odd data bits output on DAV falling edge) |
|        |                  |        | 1     | byte wise (MSB data bits output on DAV rising edge / LSB data bits output on DAV falling edge) |
| 2 to 0 | LVDS_INTTER[2:0] | R/W    |       | internal termination for LVDS buffer (DAV and DATA)  |
|        |                  |        | 000   | no internal termination  |
|        |                  |        | 001   | 300 $\Omega$   |
|        |                  |        | 010   | 180 $\Omega$   |
|        |                  |        | 011   | 110 $\Omega$   |
|        |                  |        | 100   | 150 $\Omega$   |
|        |                  |        | 101   | 100 $\Omega$   |
|        |                  |        | 110   | 81 $\Omega$  |
|        |                  |        | 111   | 60 $\Omega$  |

12. Package outline

HVQFN40: plastic thermal enhanced very thin quad flat package; no leads;  
40 terminals; body 6 x 6 x 0.85 mm

SOT618-6

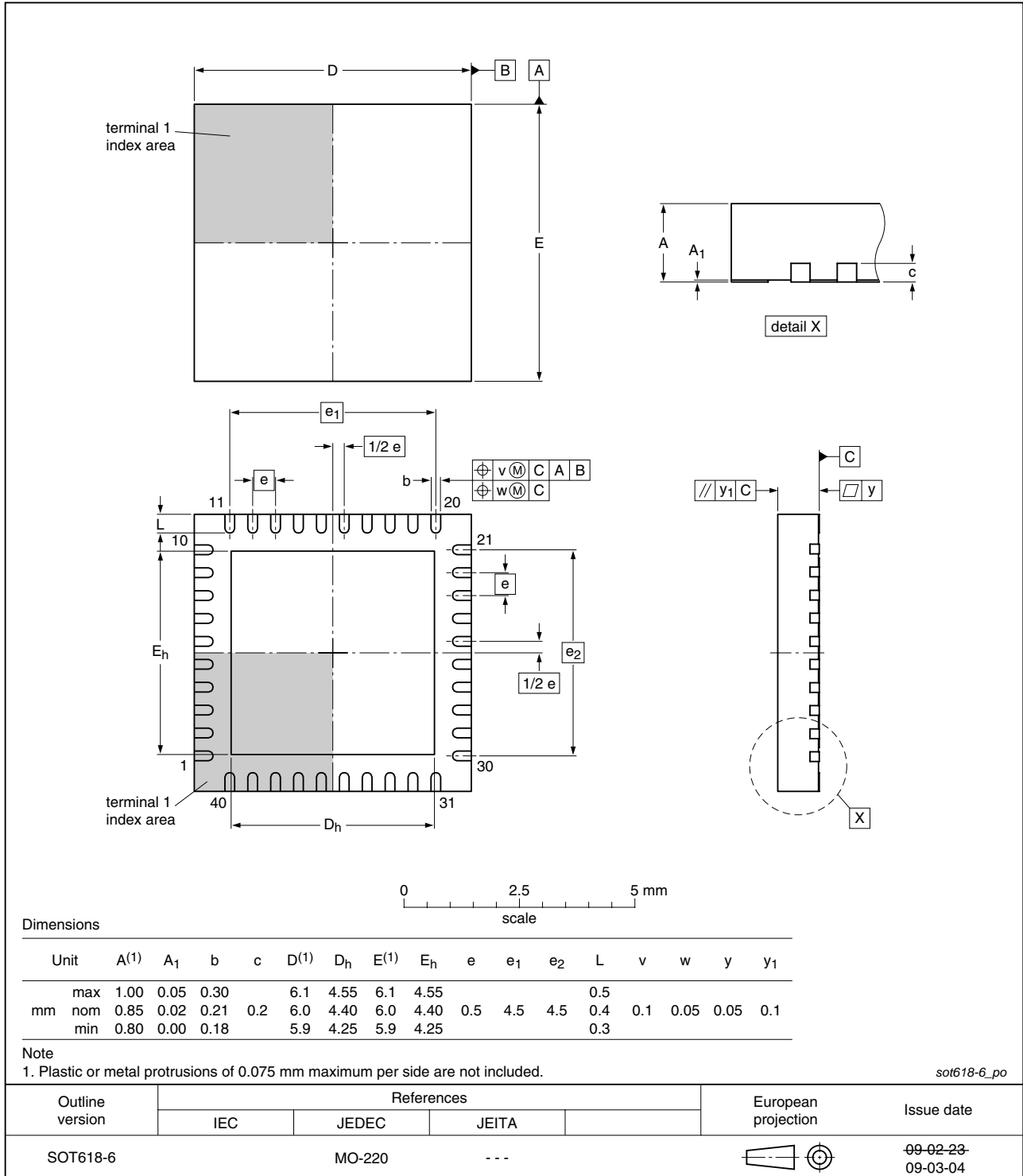

Fig 25. Package outline SOT618-6 (HVQFN40)

## 13. Revision history

Table 33. Revision history

| Document ID    | Release date | Data sheet status      | Change notice | Supersedes |
|----------------|--------------|------------------------|---------------|------------|
| ADC1015S_SER_1 | 20100412     | Preliminary data sheet | -             | -          |

## 14. Legal information

### 14.1 Data sheet status

| Document status <sup>[1][2]</sup> | Product status <sup>[3]</sup> | Definition  |
|-----------------------------------|-------------------------------|---|
| Objective [short] data sheet      | Development                   | This document contains data from the objective specification for product development. |
| Preliminary [short] data sheet    | Qualification                 | This document contains data from the preliminary specification.                       |
| Product [short] data sheet        | Production                    | This document contains the product specification.                                     |

[1] Please consult the most recently issued document before initiating or completing a design.

[2] The term 'short data sheet' is explained in section "Definitions".

[3] The product status of device(s) described in this document may have changed since this document was published and may differ in case of multiple devices. The latest product status information is available on the Internet at URL <http://www.nxp.com>.

### 14.2 Definitions

**Draft** — The document is a draft version only. The content is still under internal review and subject to formal approval, which may result in modifications or additions. NXP Semiconductors does not give any representations or warranties as to the accuracy or completeness of information included herein and shall have no liability for the consequences of use of such information.

**Short data sheet** — A short data sheet is an extract from a full data sheet with the same product type number(s) and title. A short data sheet is intended for quick reference only and should not be relied upon to contain detailed and full information. For detailed and full information see the relevant full data sheet, which is available on request via the local NXP Semiconductors sales office. In case of any inconsistency or conflict with the short data sheet, the full data sheet shall prevail.

**Product specification** — The information and data provided in a Product data sheet shall define the specification of the product as agreed between NXP Semiconductors and its customer, unless NXP Semiconductors and customer have explicitly agreed otherwise in writing. In no event however, shall an agreement be valid in which the NXP Semiconductors product is deemed to offer functions and qualities beyond those described in the Product data sheet.

### 14.3 Disclaimers

**Limited warranty and liability** — Information in this document is believed to be accurate and reliable. However, NXP Semiconductors does not give any representations or warranties, expressed or implied, as to the accuracy or completeness of such information and shall have no liability for the consequences of use of such information.

In no event shall NXP Semiconductors be liable for any indirect, incidental, punitive, special or consequential damages (including - without limitation - lost profits, lost savings, business interruption, costs related to the removal or replacement of any products or rework charges) whether or not such damages are based on tort (including negligence), warranty, breach of contract or any other legal theory.

Notwithstanding any damages that customer might incur for any reason whatsoever, NXP Semiconductors' aggregate and cumulative liability towards customer for the products described herein shall be limited in accordance with the *Terms and conditions of commercial sale* of NXP Semiconductors.

**Right to make changes** — NXP Semiconductors reserves the right to make changes to information published in this document, including without limitation specifications and product descriptions, at any time and without notice. This document supersedes and replaces all information supplied prior to the publication hereof.

**Suitability for use** — NXP Semiconductors products are not designed, authorized or warranted to be suitable for use in life support, life-critical or safety-critical systems or equipment, nor in applications where failure or

malfunction of an NXP Semiconductors product can reasonably be expected to result in personal injury, death or severe property or environmental damage. NXP Semiconductors accepts no liability for inclusion and/or use of NXP Semiconductors products in such equipment or applications and therefore such inclusion and/or use is at the customer's own risk.

**Applications** — Applications that are described herein for any of these products are for illustrative purposes only. NXP Semiconductors makes no representation or warranty that such applications will be suitable for the specified use without further testing or modification.

Customers are responsible for the design and operation of their applications and products using NXP Semiconductors products, and NXP Semiconductors accepts no liability for any assistance with applications or customer product design. It is customer's sole responsibility to determine whether the NXP Semiconductors product is suitable and fit for the customer's applications and products planned, as well as for the planned application and use of customer's third party customer(s). Customers should provide appropriate design and operating safeguards to minimize the risks associated with their applications and products.

NXP Semiconductors does not accept any liability related to any default, damage, costs or problem which is based on any weakness or default in the customer's applications or products, or the application or use by customer's third party customer(s). Customer is responsible for doing all necessary testing for the customer's applications and products using NXP Semiconductors products in order to avoid a default of the applications and the products or of the application or use by customer's third party customer(s). NXP does not accept any liability in this respect.

**Limiting values** — Stress above one or more limiting values (as defined in the Absolute Maximum Ratings System of IEC 60134) will cause permanent damage to the device. Limiting values are stress ratings only and (proper) operation of the device at these or any other conditions above those given in the Recommended operating conditions section (if present) or the Characteristics sections of this document is not warranted. Constant or repeated exposure to limiting values will permanently and irreversibly affect the quality and reliability of the device.

**Terms and conditions of commercial sale** — NXP Semiconductors products are sold subject to the general terms and conditions of commercial sale, as published at <http://www.nxp.com/profile/terms>, unless otherwise agreed in a valid written individual agreement. In case an individual agreement is concluded only the terms and conditions of the respective agreement shall apply. NXP Semiconductors hereby expressly objects to applying the customer's general terms and conditions with regard to the purchase of NXP Semiconductors products by customer.

**No offer to sell or license** — Nothing in this document may be interpreted or construed as an offer to sell products that is open for acceptance or the grant, conveyance or implication of any license under any copyrights, patents or other industrial or intellectual property rights.

**Export control** — This document as well as the item(s) described herein may be subject to export control regulations. Export might require a prior authorization from national authorities.

**Non-automotive qualified products** — Unless this data sheet expressly states that this specific NXP Semiconductors product is automotive qualified, the product is not suitable for automotive use. It is neither qualified nor tested in accordance with automotive testing or application requirements. NXP Semiconductors accepts no liability for inclusion and/or use of non-automotive qualified products in automotive equipment or applications.

In the event that customer uses the product for design-in and use in automotive applications to automotive specifications and standards, customer (a) shall use the product without NXP Semiconductors' warranty of the product for such automotive applications, use and specifications, and (b) whenever customer uses the product for automotive applications beyond

NXP Semiconductors' specifications such use shall be solely at customer's own risk, and (c) customer fully indemnifies NXP Semiconductors for any liability, damages or failed product claims resulting from customer design and use of the product for automotive applications beyond NXP Semiconductors' standard warranty and NXP Semiconductors' product specifications.

## 14.4 Trademarks

Notice: All referenced brands, product names, service names and trademarks are the property of their respective owners.

## 15. Contact information

For more information, please visit: <http://www.nxp.com>

For sales office addresses, please send an email to: [salesaddresses@nxp.com](mailto:salesaddresses@nxp.com)

## 16. Contents

|           |  |           |           |                                      |           |
|-----------|--|-----------|-----------|--------------------------------------|-----------|
| <b>1</b>  | <b>General description</b> . . . . .                 | <b>1</b>  | <b>12</b> | <b>Package outline</b> . . . . .     | <b>35</b> |
| <b>2</b>  | <b>Features and benefits</b> . . . . .               | <b>1</b>  | <b>13</b> | <b>Revision history</b> . . . . .    | <b>36</b> |
| <b>3</b>  | <b>Applications</b> . . . . .                        | <b>2</b>  | <b>14</b> | <b>Legal information</b> . . . . .   | <b>37</b> |
| <b>4</b>  | <b>Ordering information</b> . . . . .                | <b>2</b>  | 14.1      | Data sheet status . . . . .          | 37        |
| <b>5</b>  | <b>Block diagram</b> . . . . .                       | <b>3</b>  | 14.2      | Definitions . . . . .                | 37        |
| <b>6</b>  | <b>Pinning information</b> . . . . .                 | <b>4</b>  | 14.3      | Disclaimers . . . . .                | 37        |
| 6.1       | Pinning . . . . .                                    | 4         | 14.4      | Trademarks . . . . .                 | 38        |
| 6.2       | Pin description . . . . .                            | 4         | <b>15</b> | <b>Contact information</b> . . . . . | <b>38</b> |
| <b>7</b>  | <b>Limiting values</b> . . . . .                     | <b>6</b>  | <b>16</b> | <b>Contents</b> . . . . .            | <b>39</b> |
| <b>8</b>  | <b>Thermal characteristics</b> . . . . .             | <b>6</b>  |           |                                      |           |
| <b>9</b>  | <b>Static characteristics</b> . . . . .              | <b>7</b>  |           |                                      |           |
| <b>10</b> | <b>Dynamic characteristics</b> . . . . .             | <b>10</b> |           |                                      |           |
| 10.1      | Dynamic characteristics . . . . .                    | 10        |           |                                      |           |
| 10.2      | Clock and digital output timing . . . . .            | 12        |           |                                      |           |
| 10.3      | SPI timings . . . . .                                | 15        |           |                                      |           |
| <b>11</b> | <b>Application information</b> . . . . .             | <b>15</b> |           |                                      |           |
| 11.1      | Device control . . . . .                             | 15        |           |                                      |           |
| 11.1.1    | SPI and Pin control modes . . . . .                  | 15        |           |                                      |           |
| 11.1.2    | Operating mode selection . . . . .                   | 16        |           |                                      |           |
| 11.1.3    | Selecting the output data standard . . . . .         | 16        |           |                                      |           |
| 11.1.4    | Selecting the output data format . . . . .           | 16        |           |                                      |           |
| 11.2      | Analog inputs . . . . .                              | 16        |           |                                      |           |
| 11.2.1    | Input stage . . . . .                                | 16        |           |                                      |           |
| 11.2.2    | Transformer . . . . .                                | 17        |           |                                      |           |
| 11.3      | System reference and power management . . . . .      | 19        |           |                                      |           |
| 11.3.1    | Internal/external references . . . . .               | 19        |           |                                      |           |
| 11.3.2    | Reference gain control . . . . .                     | 20        |           |                                      |           |
| 11.3.3    | Common-mode output voltage ( $V_{O(cm)}$ ) . . . . . | 20        |           |                                      |           |
| 11.3.4    | Biasing . . . . .                                    | 20        |           |                                      |           |
| 11.4      | Clock input . . . . .                                | 21        |           |                                      |           |
| 11.4.1    | Drive modes . . . . .                                | 21        |           |                                      |           |
| 11.4.2    | Equivalent input circuit . . . . .                   | 22        |           |                                      |           |
| 11.4.3    | Duty cycle stabilizer . . . . .                      | 22        |           |                                      |           |
| 11.4.4    | Clock input divider . . . . .                        | 22        |           |                                      |           |
| 11.5      | Digital outputs . . . . .                            | 23        |           |                                      |           |
| 11.5.1    | Digital output buffers: CMOS mode . . . . .          | 23        |           |                                      |           |
| 11.5.2    | Digital output buffers: LVDS DDR mode . . . . .      | 24        |           |                                      |           |
| 11.5.3    | Data valid (DAV) output clock . . . . .              | 25        |           |                                      |           |
| 11.5.4    | Out-of-Range (OTR) . . . . .                         | 25        |           |                                      |           |
| 11.5.5    | Digital offset . . . . .                             | 25        |           |                                      |           |
| 11.5.6    | Test patterns . . . . .                              | 25        |           |                                      |           |
| 11.5.7    | Output codes versus input voltage . . . . .          | 26        |           |                                      |           |
| 11.6      | Serial peripheral interface . . . . .                | 26        |           |                                      |           |
| 11.6.1    | Register description . . . . .                       | 26        |           |                                      |           |
| 11.6.2    | Default modes at start-up . . . . .                  | 27        |           |                                      |           |
| 11.6.3    | Register allocation map . . . . .                    | 29        |           |                                      |           |

Please be aware that important notices concerning this document and the product(s) described herein, have been included in section 'Legal information'.

© NXP B.V. 2010. All rights reserved.

For more information, please visit: <http://www.nxp.com>  
For sales office addresses, please send an email to: [salesaddresses@nxp.com](mailto:salesaddresses@nxp.com)

Date of release: 12 April 2010  
Document identifier: ADC1015S\_SER\_1