

FEATURES

- 2.25V to 5.5V Operating Voltage Range
- Low Power Consumption (2 μ A)
- Output Stages
 - ADCMP370: Open-Drain with High Voltage (22V) Tolerance
 - ADCMP371: Push-Pull
- 10nA Input Bias Current
- 5nA Input Offset Current
- 6mV Input Offset Voltage
- 0V to V_{CC} Common Mode Input Range
- Specified Over -40°C to +125°C Temperature Range
- 5-Lead SC70 Package

APPLICATIONS

- Voltage Detectors
- Battery Management Systems
- A/D Converters
- Low Voltage Applications
- Battery Powered Electronics
- Portable Equipment

GENERAL DESCRIPTION

The ADCMP370/ADCMP371 are general purpose comparators with input offset voltages of 6mV (max). High performance over the -40°C to +125°C temperature range make them suitable for use in automotive and other thermally harsh applications, while low power consumption and space efficient SC70 packaging make them ideal for battery powered portable equipment.

The ADCMP371 has a push-pull output stage, while the ADCMP370 has an open-drain output, which can be pulled as high as 22V through an external resistor.

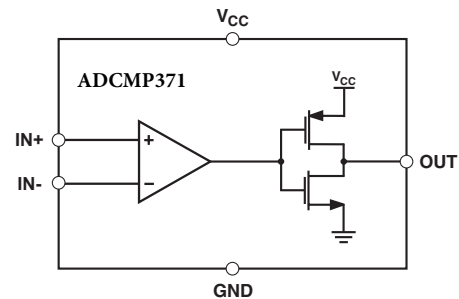
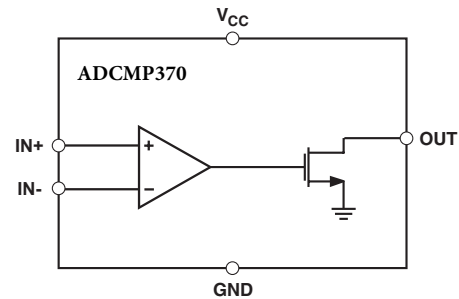
FUNCTIONAL BLOCK DIAGRAMS**Rev.PrB**

Information furnished by Analog Devices is believed to be accurate and reliable. However, no responsibility is assumed by Analog Devices for its use, nor for any infringements of patents or other rights of third parties that may result from its use. Specifications subject to change without notice. No license is granted by implication or otherwise under any patent or patent rights of Analog Devices. Trademarks and registered trademarks are the property of their respective companies.

SPECIFICATIONS

(V_{CC} =Full Operating Range, T_A =-40°C to +125°C, unless otherwise noted.)

Parameter	Min	Typ	Max	Units	Test Conditions/Comments
SUPPLY					
V_{CC} Operating Voltage Range	2.25		5.5	V	
Supply Current		2	5	μ A	
COMMON MODE INPUT RANGE	0		V_{CC}	V	
INPUT OFFSET VOLTAGE			6	mV	
INPUT BIAS CURRENT		10		nA	$V_{CC} = 3.3V$
INPUT OFFSET CURRENT		5	150	nA	
OUT VOLTAGE LOW			0.3	V	$IN+ < IN-, I_{SINK}=1.2mA$
OUT VOLTAGE HIGH (ADCMP371)	$0.8V_{CC}$			V	$IN+ > IN-, I_{SOURCE}=500\mu A$
OUT LEAKAGE CURRENT (ADCMP370)			1	μ A	$IN+ > IN-, OUT=22V$
TIMING					
Propagation Delay		5	10	μ s	Input Overdrive=10mV
		1	2	μ s	Input Overdrive=100mV

ABSOLUTE MAXIMUM RATINGS

Table 3. $T_A = 25^\circ\text{C}$ unless otherwise noted.

Parameter	Rating
V_{CC}	-0.3V to +6V
IN+, IN-	-0.3V to +6V
OUT (ADCMP370)	-0.3V to +25V
OUT (ADCMP371)	-0.3V to $V_{CC}+0.3V$
Operating Temperature Range	-40°C to +125°C
Storage Temperature Range	-65°C to +150°C
θ_{JA} Thermal Impedance, SC70	146°C/W
Lead Temperature	
Soldering (10 sec)	300°C
Vapour Phase (60 sec)	215°C
Infrared (15 sec)	220°C

Stresses above those listed under Absolute Maximum Ratings may cause permanent damage to the device. This is a stress rating only and functional operation of the device at these or any other conditions above those indicated in the operational section of this specification is not implied. Exposure to absolute maximum rating conditions for extended periods may affect device reliability.

PIN CONFIGURATIONS AND FUNCTIONAL DESCRIPTIONS

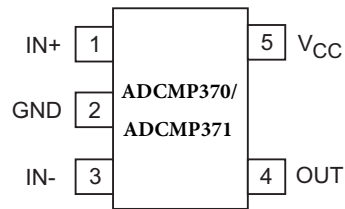

Table 4. Pin Functional Descriptions

Pin No.	Name	Description
1	IN+	Non-Inverting Input
2	GND	Ground
3	IN-	Inverting Input
4	OUT	Comparator Output. Open-Drain for ADCMP370. Push-Pull for ADCMP371.
5	V _{CC}	Power Supply

ESD CAUTION

ESD (electrostatic discharge) sensitive device. Electrostatic charges as high as 4000 V readily accumulate on the human body and test equipment and can discharge without detection. Although this product features proprietary ESD protection circuitry, permanent damage may occur on devices subjected to high energy electrostatic discharges. Therefore, proper ESD precautions are recommended to avoid performance degradation or loss of functionality.



TYPICAL PERFORMANCE CHARACTERISTICS

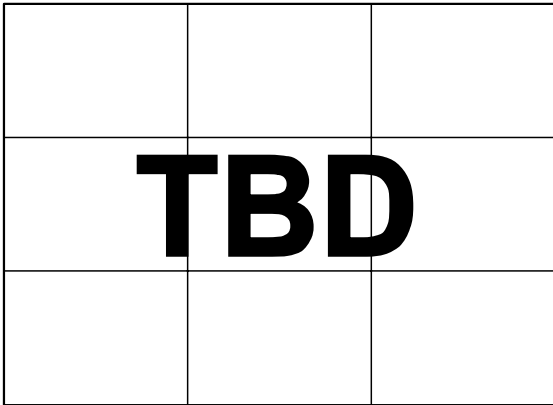

Figure 1. Supply Current vs. Supply Voltage Output High

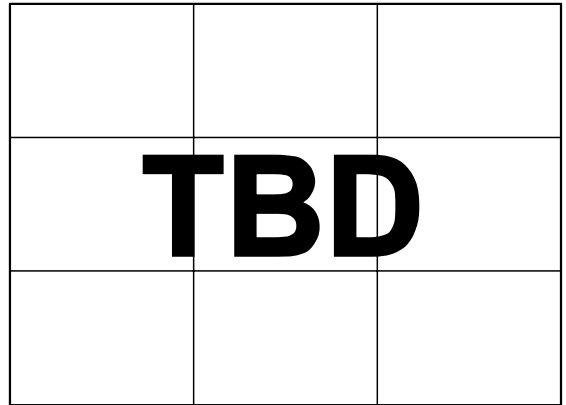

Figure 4. Output Voltage vs. Output Current at 2.7V Supply

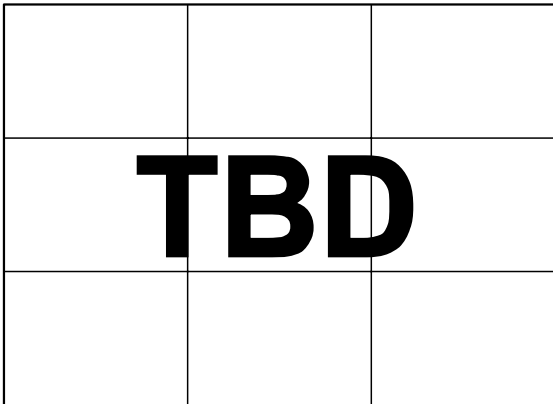

Figure 2. Supply Current vs. Supply Voltage Output Low

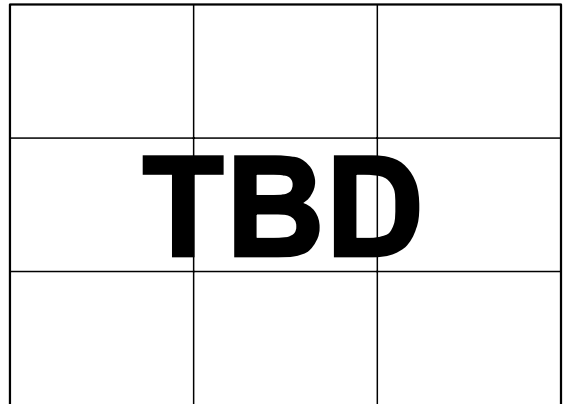

Figure 5. Input Bias Current vs. Supply Voltage

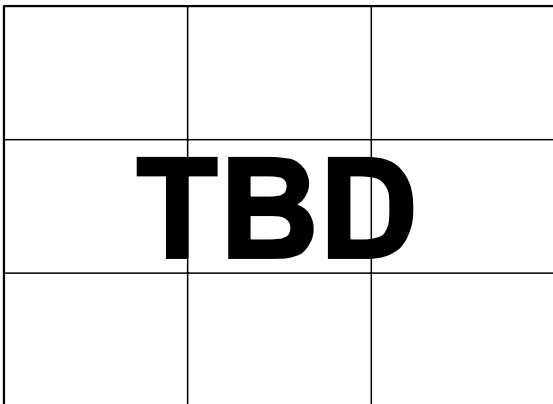

Figure 3. Output Voltage vs. Output Current at 5V Supply

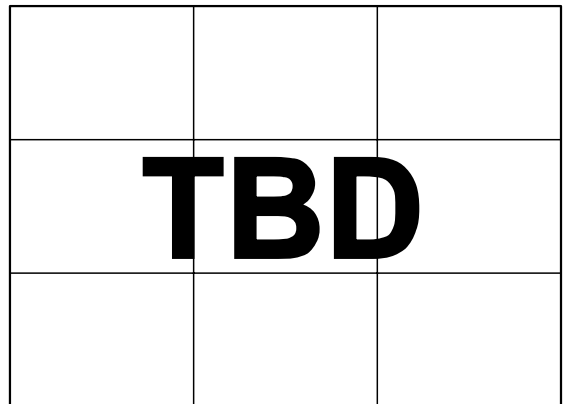

Figure 6. Response Time vs. Input Overdrives Negative Transition (5V)

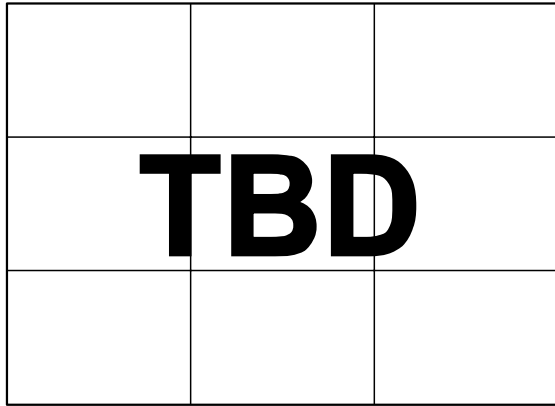

Figure 7. Response Time vs. Input Overdrives Positive Transition (5V)

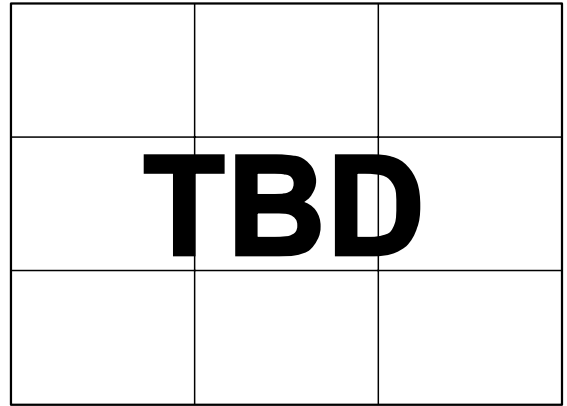

Figure 10. Output Saturation Voltage vs. Output Sink Current

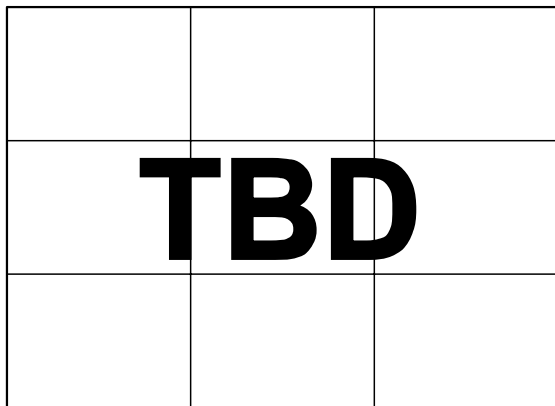

Figure 8. Response Time vs. Input Overdrives Negative Transition(2.7V)

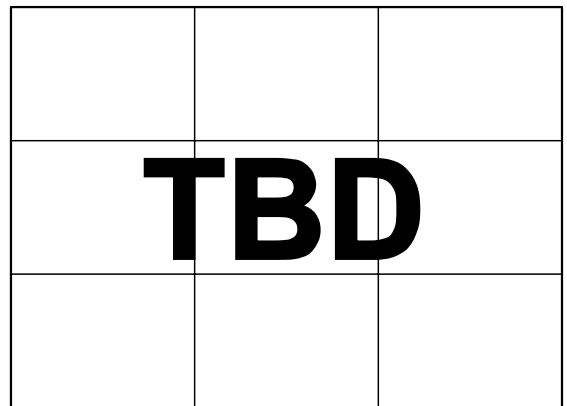

Figure 11. 10kHz Response

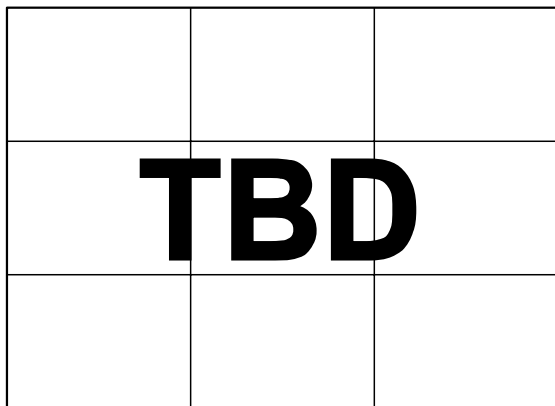

Figure 9. Response Time vs. Input Overdrives Positive Transition(2.7V)

APPLICATIONS INFORMATION

BASIC COMPARATOR

In its most basic configuration, a comparator can be used to convert an analog input signal to a digital output signal. The analog signal on IN+ is compared to the voltage on IN- and the voltage at OUT is either high or low depending on whether IN+ is at a higher or lower potential than IN-, respectively.

The ADCMP370 and ADCMP371 have different digital output structures. The ADCMP370 has an open-drain output stage which requires an external resistor to pull OUT to the logic high voltage level when the output transistor is switched off. This voltage level can be as high as 22V. The pull-up resistor should be large enough to avoid excessive power dissipation, but small enough to switch logic levels reasonably quickly when the comparator output is connected to other digital circuitry. A suitable value would be between 1kΩ and 10kΩ. The ADCMP371 has a push-pull output stage which has an internal PMOS pull-up and therefore doesn't require an external resistor. Faster switching speeds between low and high rails are possible, but the logic high level is limited to V_{CC}.

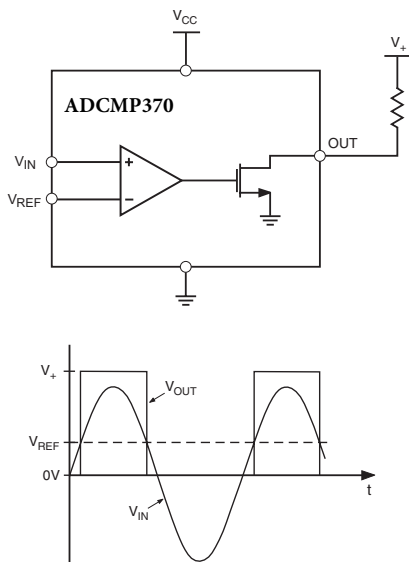

Figure 12. Basic Comparator and Input and Output Signals

ADDING HYSTERESIS

To prevent oscillations at the output caused by noise or slowly moving signals passing the switching threshold, positive feedback can be used to add hysteresis to the differential input.

For the non-inverting configuration, shown in figure 13, two resistors are used to create different switching thresholds depending on whether the input signal is increasing or decreasing in magnitude. When the input voltage is increasing,

the threshold is above V_{REF} and when it's decreasing, the threshold is below V_{REF}.

The upper input threshold level is given by:

$$V_{IN_HI} = \frac{V_{REF}(R1 + R2) - V_{CC}R1}{R2}$$

The lower input threshold level is given by:

$$V_{IN_LO} = \frac{V_{REF}(R1 + R2)}{R2}$$

The hysteresis is the difference between these voltage levels:

$$\Delta V_{IN} = \frac{V_{CC}R1}{R2}$$

In the example in figure 13, resistors R1 and R2 are chosen to give 1V hysteresis about the reference of 2.5V, with V_{CC}=5V. It's important that R_{PULL-UP}<<R_{LOAD} so that the output high voltage isn't pulled below V_{CC}.

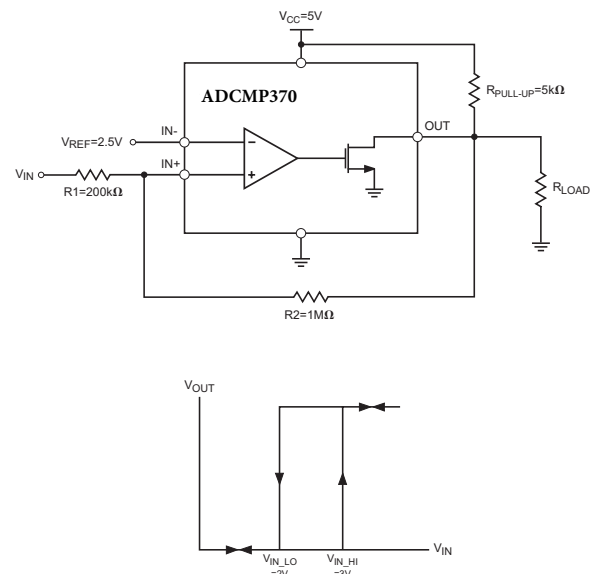

Figure 13. Non-Inverting Comparator Configuration with Hysteresis

With the inverting configuration, the upper and lower switching thresholds are as follows:

$$V_{IN_HI} = \frac{V_{CC} R2}{(R1 \parallel R3) + R2}$$

$$V_{IN_LO} = \frac{V_{CC} (R2 \parallel R3)}{R1 + (R2 \parallel R3)}$$

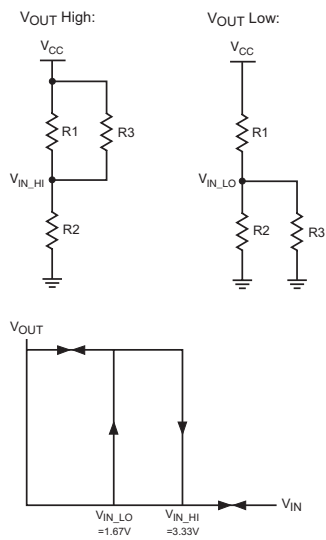
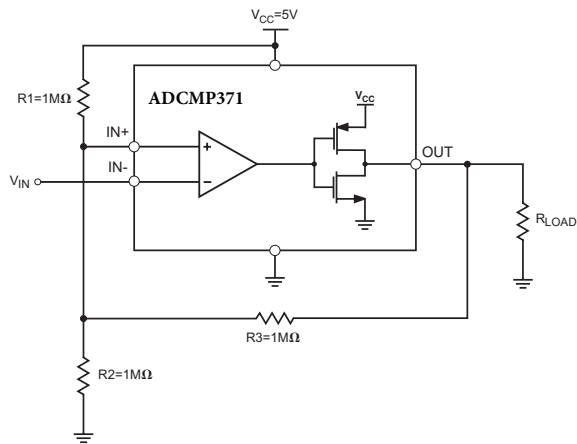

Figure 14. Non-Inverting Comparator Configuration with Hysteresis

OUTLINE DIMENSIONS

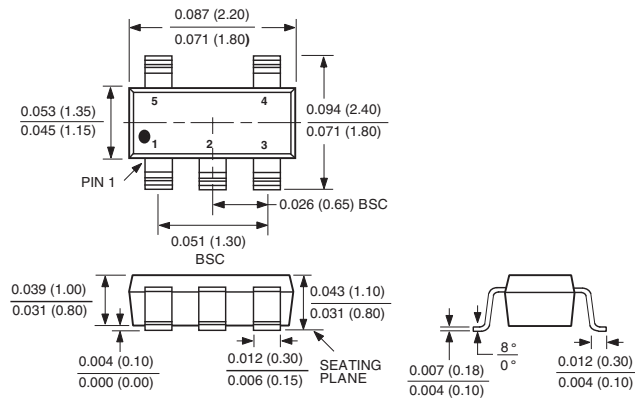

Figure 1. 5-Lead Plastic Surface Mount Package [SC70]

(KS-5)

Dimensions shown in millimeters

ORDERING GUIDE

Model	Temperature Range	Quantity	Package Type	Branding
ADCMP370AKS-R7	-40°C to +125°C	3k	SC70-5	M1F
ADCMP370AKS-RL	-40°C to +125°C	10k	SC70-5	M1F
ADCMP371AKS-R7	-40°C to +125°C	3k	SC70-5	M1G
ADCMP371AKS-RL	-40°C to +125°C	10k	SC70-5	M1G