



Programmable Dual Axis Digital Accelerometer and Impact Sensor

Preliminary Technical Data

ADIS16204

FEATURES

- Dual-axis impact sensing**
- Dual-axis acceleration sensing, $\pm 70g$, $\pm 35g$**
- 14-bit resolution**
- 17.1 mg/LSB, 8.55mg/LSB sensitivity**
- Impact peak-level sample and hold**
- Programmable Event Recorder**
- 400Hz double-pole Bessel sensor response**
- 12-bit digital temperature sensor output**
- Digitally controlled sensitivity and bias**
- Digitally controlled sample rate, up to 4096 SPS**
- Dual alarm settings with programmable threshold limits**
- Auxiliary digital I/O**
- Digitally activated self test**
- Digitally activated low power mode**
- SPI®-compatible serial interface**
- Auxiliary 12-bit ADC input and DAC output**
- Single-supply operation: 3.0 V to +3.6 V**
- 3500 g powered shock survivability**

APPLICATIONS

- Impact detection**
- Condition monitoring**
- Safety Systems**
- Shock sensor**

GENERAL DESCRIPTION

The ADIS16204 is a programmable impact sensor in a single compact package enabled by the Analog Devices *iSensor*™ integration. By enhancing the Analog Devices *iMEMS*® sensor technology with an embedded signal processing solution, the ADIS16204 provides tunable digital sensor data in a convenient format that can be accessed using a serial peripheral interface (SPI). The SPI interface provides access to measurements for dual-axis linear acceleration, a root-sum-square (RSS) of both axes, temperature, power supply, and one auxiliary analog input. Easy access to digital sensor data provides developers with a system-ready device, reducing development time, cost, and program risk.

Unique characteristics of the end system are accommodated easily through several built-in features, such as a single command in-system offset calibration, along with convenient sample rate control.

FUNCTIONAL BLOCK DIAGRAM

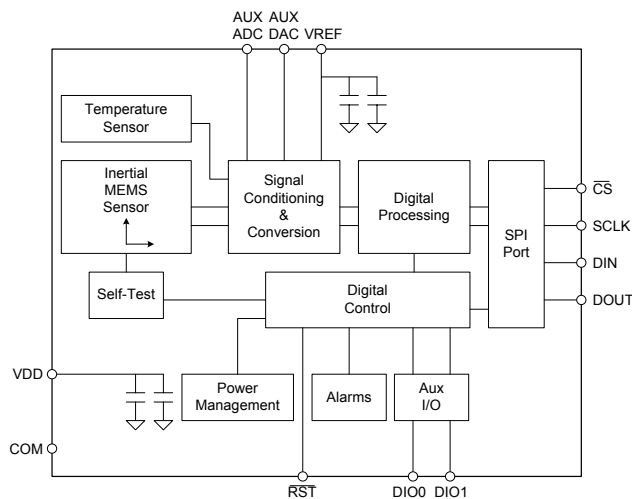

Figure 1.

The ADIS16204 offers the following embedded features, which eliminate the need for external circuitry and provide a simplified system interface:

- Peak sample and hold
- Programmable Event Recording
- Configurable trigger levels
- Auxiliary 12-bit ADC and DAC
- Configurable digital I/O port
- Digital self-test function

The ADIS16204 offers two power management features for managing system-level power dissipation: low power mode and a configurable shutdown feature.

The ADIS16204 is available in a 9.2 mm × 9.2 mm × 3.9 mm laminate-based land grid array (LGA) package with a temperature range of -40°C to $+105^{\circ}\text{C}$.

Rev. PrA

10/10/2006 4:24 AM

Information furnished by Analog Devices is believed to be accurate and reliable. However, no responsibility is assumed by Analog Devices for its use, nor for any infringements of patents or other rights of third parties that may result from its use. Specifications subject to change without notice. No license is granted by implication or otherwise under any patent or patent rights of Analog Devices. Trademarks and registered trademarks are the property of their respective owners.

www.DataSheet4U.com

One Technology Way, P.O. Box 9106, Norwood, MA 02062-9106, U.S.A.

Tel: 781.329.4700

www.analog.com

Fax: 781.461.3113

©2006 Analog Devices, Inc. All rights reserved.

TABLE OF CONTENTS

Features	1	Timing Diagrams	5
Applications.....	1	Absolute Maximum Ratings	6
Functional Block Diagram	1	ESD Caution.....	6
General Description	1	Pin Configuration and Function Descriptions.....	7
Revision History	2	RECOMMENDED PAD GEOMETRY	7
Specifications.....	3	Outline Dimensions	8
Timing Specifications	5	Ordering Guide	8

REVISION HISTORY

8/06—Revision PSD1: PSD1 Kickoff Version

SPECIFICATIONS

T_A = -40°C to +105°C, V_{DD} = 3.3 V, unless otherwise noted.

Table 1.

Parameter	Conditions	Axis	Min	Typ	Max	Unit
ACCELEROMETER						
Output Full-Scale Range		X	±70			g
		Y	±35			g
Sensitivity		X		17.1		mg/LSB
		Y		8.55		mg/LSB
Non linearity				0.2		%
Sensor-to-sensor Alignment Error				0.1		Degrees
Cross-axis Sensitivity			-5		+5	%
Resonant Frequency				24		kHz
OFFSET						
Zero-g Output		X		0.2		g
		Y		1.85		g
NOISE						
Noise Density	10Hz – 400Hz, no post filtering			1.8		mg/√Hz
FREQUENCY RESPONSE						
Sensor Bandwidth (-3dB)	2-pole Bessel		360	400	440	Hz
Temperature Drift	25° - T _{min} or T _{max} - 25°C			2		Hz
ACCELEROMETER SELF-TEST STATE¹						
Output Change When Active	25°C	X		585		LSB
Output Change When Active		Y		1170		LSB
TEMPERATURE SENSOR						
Output at 25°C				1278		LSB
Scale Factor				-2.13		LSB/°C
ADC INPUT						
Resolution				12		Bits
Integral Nonlinearity				±2		LSB
Differential Nonlinearity				±1		LSB
Offset Error				±4		LSB
Gain Error				±2		LSB
Input Range			0		2.5	V
Input Capacitance	During acquisition			20		pF
ON-CHIP VOLTAGE REFERENCE						
Accuracy	At 25°C		-10		+10	mV
Reference Temperature Coefficient				±40		ppm/°C
Output Impedance				70		Ω
DAC OUTPUT						
	5 kΩ/100 pF to GND					
Resolution				12		Bits
Relative Accuracy	For Code 101 to Code 4095			4		LSB
Differential Nonlinearity				1		LSB
Offset Error				±5		mV
Gain Error				±0.5		%
Output Range				0 to 2.5		V
Output Impedance				2		Ω
Output Settling Time				10		μs

ADIS16204**Preliminary Technical Data**

Parameter	Conditions	Axis	Min	Typ	Max	Unit
LOGIC INPUTS						
Input High Voltage, V_{INH}			2.0			V
Input Low Voltage, V_{INL}					0.8	V
Logic 1 Input Current, I_{INH}	$V_{IH} = V_{DD}$			± 0.2	± 1	μA
Logic 0 Input Current, I_{INL}	$V_{IL} = 0V$			-40	-60	μA
Input Capacitance, C_{IN}				10		pF
DIGITAL OUTPUTS						
Output High Voltage, V_{OH}	$I_{SOURCE} = 1.6 mA$		2.4			V
Output Low Voltage, V_{OL}	$I_{SINK} = 1.6 mA$				0.4	V
SLEEP TIMER						
Timeout Period ²			0.5		128	Seconds
FLASH MEMORY						
Endurance ³			20,000			Cycles
Data Retention ⁴	$T_J = 85^\circ C$		20			Years
CONVERSION RATE						
Minimum Conversion Time				244		μs
Maximum Conversion Time				484		ms
Maximum Throughput Rate				4096		SPS
Minimum Throughput Rate				2.066		SPS
POWER SUPPLY						
Operating Voltage Range V_{DD}			3.0	3.3	3.6	V
Power Supply Current	Normal mode, $SMPL_TIME \geq 0x08$ ($f_s \leq 910 Hz$), at $25^\circ C$			12		mA
	Fast mode, $SMPL_TIME \leq 0x07$ ($f_s \geq 1024 Hz$), at $25^\circ C$			37		mA
	Sleep mode, at $25^\circ C$			500	750	μA
Turn-On Time				130		ms

¹ Self-test response changes as the square of V_{DD} .

² Guaranteed by design.

³ Endurance is qualified as per JEDEC Standard 22 Method A117 and measured at $-40^\circ C$, $+25^\circ C$, $+85^\circ C$, and $+105^\circ C$.

⁴ Retention lifetime equivalent at junction temperature (T_J) $55^\circ C$ as per JEDEC Standard 22 Method A117. Retention lifetime decreases with junction temperature.

TIMING SPECIFICATIONS

$T_A = 25^\circ\text{C}$, $V_{DD} = 3.3\text{ V}$, tilt = 0° , unless otherwise noted.

Table 2.

Parameter	Description	Min ¹	Typ	Max	Unit
f_{SCLK}	Fast mode, $\text{SMPL_TIME} \leq 0x07$ ($f_s \geq 1024\text{ Hz}$)	0.01		2.5	MHz
	Normal mode, $\text{SMPL_TIME} \geq 0x08$ ($f_s \leq 910\text{ Hz}$)	0.01		1.0	MHz
t_{Datarate}	Chip select period, fast mode, $\text{SMPL_TIME} \leq 0x07$ ($f_s \geq 1024\text{ Hz}$)	40			μs
t_{Datarate}	Chip select period, normal mode, $\text{SMPL_TIME} \geq 0x08$ ($f_s \leq 910\text{ Hz}$)	100			μs
t_{CS}	Chip select to clock edge	48.8			ns
t_{DAV}	Data output valid after SCLK edge			100	ns
t_{DSU}	Data input setup time before SCLK rising edge	24.4			ns
t_{DHD}	Data input hold time after SCLK rising edge	48.8			ns
t_{DF}	Data output fall time		5	12.5	ns min
t_{DR}	Data output rise time		5	12.5	ns min
t_{SFS}	$\overline{\text{CS}}$ high after SCLK edge	5			ns typ

¹ Guaranteed by design, not tested.

TIMING DIAGRAMS

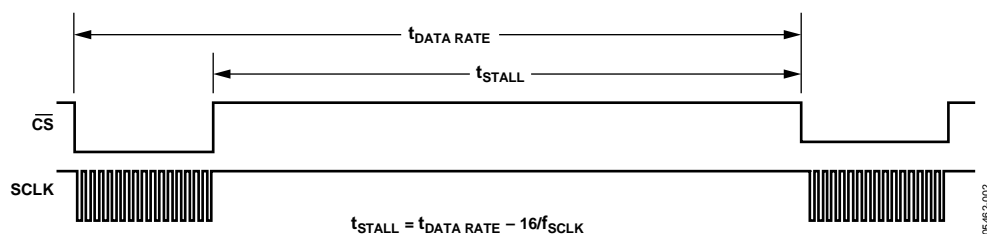

Figure 2. SPI Chip Select Timing

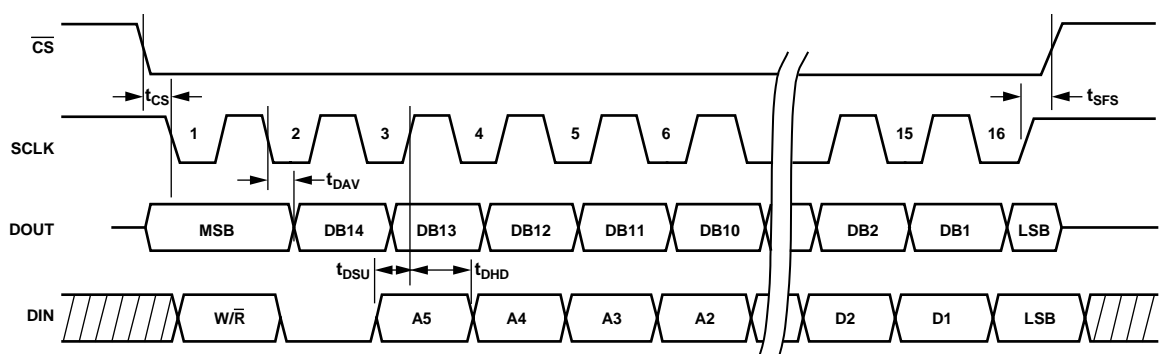

Figure 3. SPI Timing

(Utilizing SPI Settings Typically Identified as Phase = 1, Polarity = 1)

ABSOLUTE MAXIMUM RATINGS

Table 3.

Parameter	Rating
Acceleration (Any Axis, Unpowered)	3500 g
Acceleration (Any Axis, Powered)	3500 g
VDD to COM	-0.3 V to +7.0 V
Digital Input/Output Voltage to COM	-0.3 V to +5.5 V
Analog Inputs to COM	-0.3 to VDD + 0.3 V
Analog Inputs to COM	-0.3 to VDD + 0.3 V
Operating Temperature Range	-40°C to +125°C
Storage Temperature Range	-65°C to +150°C

Stresses above those listed under Absolute Maximum Ratings may cause permanent damage to the device. This is a stress rating only; functional operation of the device at these or any other conditions above those indicated in the operational section of this specification is not implied. Exposure to absolute maximum rating conditions for extended periods may affect device reliability.

Table 4. Package Characteristics

Package Type	θ_{JA}	θ_{JC}	Device Weight
16-Terminal LGA	250°C/W	25°C/W	0.6 grams

ESD CAUTION

ESD (electrostatic discharge) sensitive device. Electrostatic charges as high as 4000V readily accumulate on the human body and test equipment and can discharge without detection. Although this product features proprietary ESD protection circuitry, permanent damage may occur on devices subjected to high energy electrostatic discharges. Therefore, proper ESD precautions are recommended to avoid performance degradation or loss of functionality.



PIN CONFIGURATION AND FUNCTION DESCRIPTIONS

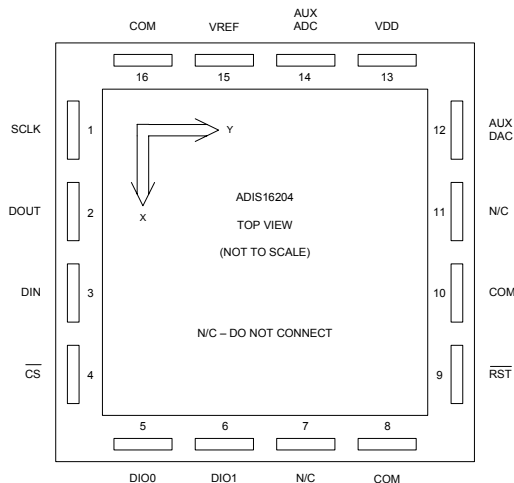

Figure 4. Pin Configuration

Table 5. Pin Function Descriptions

Pin No.	Mnemonic	Type ¹	Description
1	SCLK	I	Serial Clock. SCLK provides the serial clock for accessing data from the part and writing serial data to the control registers.
2	DOUT	O	Data Out. The data on this pin represents data being read from the control registers and is clocked out on the falling edge of the SCLK.
3	DIN	I	Data In. Data written to the control registers is provided on this input and is clocked in on the rising edge of the SCLK.
4	\overline{CS}	I	Chip Select, Active Low. This input frames the serial data transfer.
5, 6	DIO0, DIO1	I/O	Multifunction Digital I/O Pins.
7, 11	NC	–	No Connect.
8, 10	AUX COM	S	Auxiliary Grounds. Connect to GND for proper operation.
9	\overline{RST}	I	Reset, Active Low. This input resets the embedded microcontroller to a known state.
12	AUX DAC	O	Auxiliary DAC Analog Voltage Output.
13	VDD	S	+3.3 V Power Supply.
14	AUX ADC	I	Auxiliary ADC Analog Input Voltage.
15	VREF	O	Precision Reference Output.
16	COM	S	Common. Reference point for all circuitry in the ADIS16204.

¹ S = Supply; O = Output; I = Input.

RECOMMENDED PAD GEOMETRY

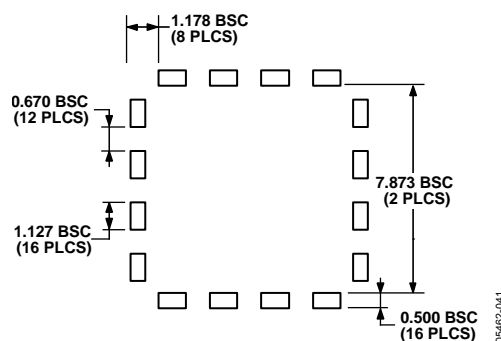

Figure 5. Example Pad Layout

OUTLINE DIMENSIONS

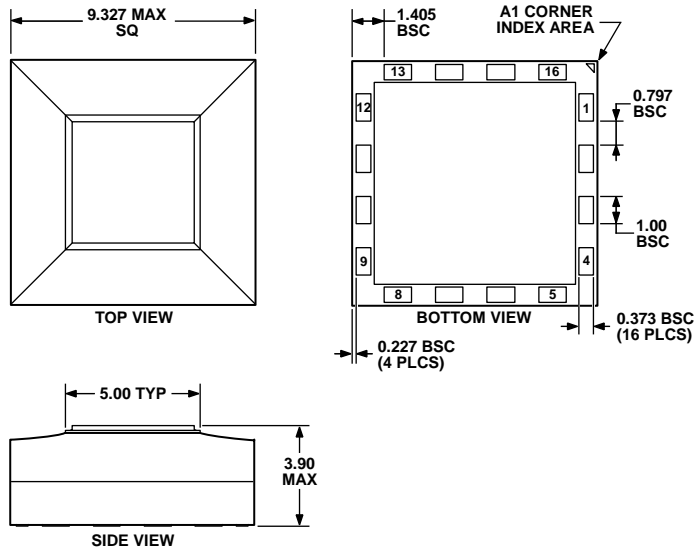

Figure 6. 16-Terminal Land Grid Array [LGA]
(CC-16-2)
Dimensions shown in millimeters

03/09/06-A

ORDERING GUIDE

Model	Temperature Range	Package Description	Package Option
ADIS16204BCCZ ¹	-40°C to +105°C	16-Terminal Land Grid Array [LGA]	CC-16-2
ADIS16204/PCBZ		Evaluation Board	

¹ Z = Pb-free part.

NOTES