

N-Channel Enhancement Mode Field Effect Transistor

PRODUCT SUMMARY

V_{DSS}	I_D	$R_{DS(ON)}$ (m Ω)
60V	22A	55m Ω

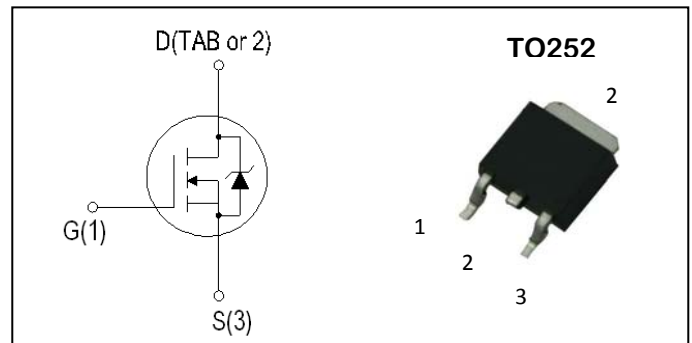

Absolute Maximum Ratings ($T_A = 25^\circ\text{C}$ unless otherwise specified)

Symbol	Parameter		Ratings	Unit
Common Ratings				
V_{DSS}	Drain-Source Voltage		60	V
V_{GSS}	Gate-Source Voltage		± 20	
T_J	Maximum Junction Temperature		150	$^\circ\text{C}$
T_{STG}	Storage Temperature Range		-55 to 150	$^\circ\text{C}$
I_S	Diode Continuous Forward Current	$T_C=25^\circ\text{C}$	22	A
Mounted on Large Heat Sink				
I_{DM}	300 μs Pulse Drain Current Tested(1)	$T_C=25^\circ\text{C}$	80	A
I_D	Continuous Drain Current	$T_C=25^\circ\text{C}$	22	A
		$T_C=70^\circ\text{C}$	18	A
P_D	Maximum Power Dissipation	$T_C=25^\circ\text{C}$	50	W
		$T_C=70^\circ\text{C}$	32	W

1. Pulse width limited by maximum junction temperature.

Thermal Characteristics

Symbol	Parameter	Ratings	Unit
R_{thJC}	Thermal resistance junction-case max	2.5	$^\circ\text{C}/\text{W}$
R_{thJA}	Thermal resistance junction-ambient max	55	$^\circ\text{C}/\text{W}$

Electrical Characteristics (TA=25°C Unless Otherwise Noted)

Symbol	Parameter	Test conditions	Min.	Typ.	Max.	Unit
On/off Characteristics						
BV _{DSS}	Drain-Source Breakdown Voltage	V _{GS} =0V, I _{DS} =250uA	60	--	--	V
I _{DSS}	Zero Gate Voltage Drain Current	V _{DS} = 48V, V _{GS} =0V	--	--	1	uA
		V _{DS} =40V, V _{GS} =0V T _J =55°C	--	--	10	
V _{GS(th)}	Gate Threshold Voltage	V _{DS} =V _{GS} , I _{DS} =250uA	1	1.5	2.5	V
I _{GSS}	Gate Leakage Current	V _{GS} =±20V, V _{DS} =0V	--	--	±250	nA
R _{DS(ON)}	Drain-SourceOn-stateResistance(2)	V _{GS} = 10V, I _{DS} =10A	--	42	55	mΩ
g _{FS}	Forward transconductance(2)	V _{DS} = 10V, I _{DS} =10A	--	14	--	S
Dynamic Characteristics						
C _{iss}	Input Capacitance	V _{GS} =0V, V _{DS} = 25V, Frequency=1.0MHz	--	587	--	pF
C _{oss}	Output Capacitance					
C _{rss}	Reverse Transfer Capacitance					
Switching Characteristics						
t _{d(ON)}	Turn-on Delay Time(1)	V _{DD} =30V, I _D = 1A, V _{GS} = 10V, R _{GEN} =6 Ω	--	11	--	ns
t _r	Turn-on Rise Time(1)					
t _{d(OFF)}	Turn-off Delay Time(1)					
t _f	Turn-off Fall Time(1)					
Q _g	Total Gate Charge(1)	V _{DS} =0.5V, V _{GS} = 10V, I _{DS} =10A	--	12.5	--	nC
Q _{gs}	Gate-Source Charge(1)					
Q _{gd}	Gate-Drain Charge(1)					
Diode Characteristics						
V _{SD}	Diode Forward Voltage(2)	I _{SD} = 1A, V _{GS} = 0	--	--	1	V
t _{rr}	Reverse Recovery Time	I _{SD} =22A, dI _{SD} /dt=100A/μs	--	65	--	ns
q _{rr}	Reverse Recovery Charge		--	150	--	nC

NOTES:

1. Independent of operating temperature.
2. Pulse Test : Pulse width ≤ 300 μ s, Duty cycle ≤ 2%

Typical Performance Characteristics

Figure 1: On-Region Characteristics

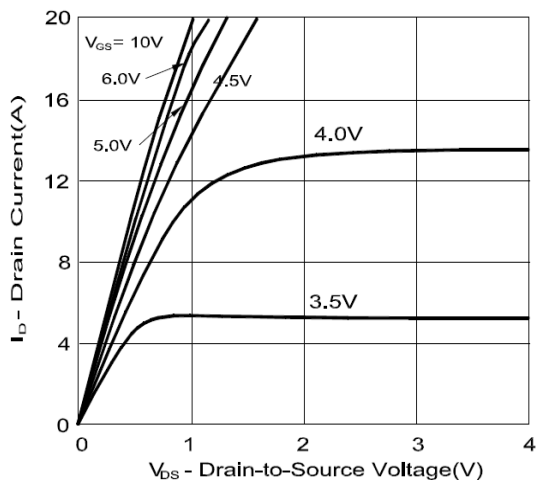

Figure 2: Transfer Characteristics

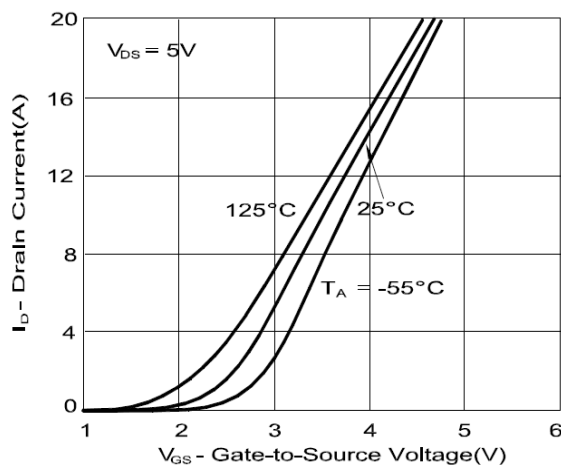

Figure 3: Drain-Source On Resistance

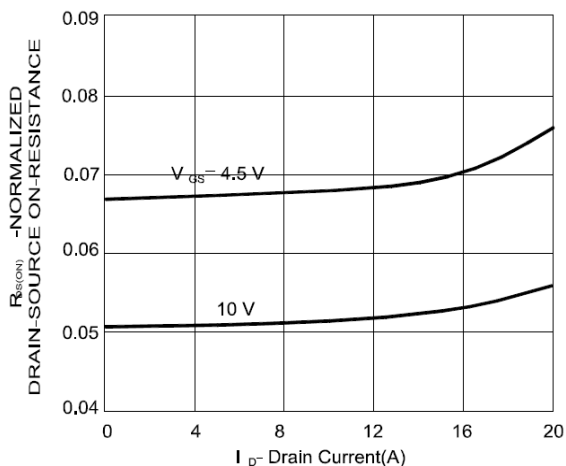

Figure 4: On-Resistance with Gate-to-source Voltage

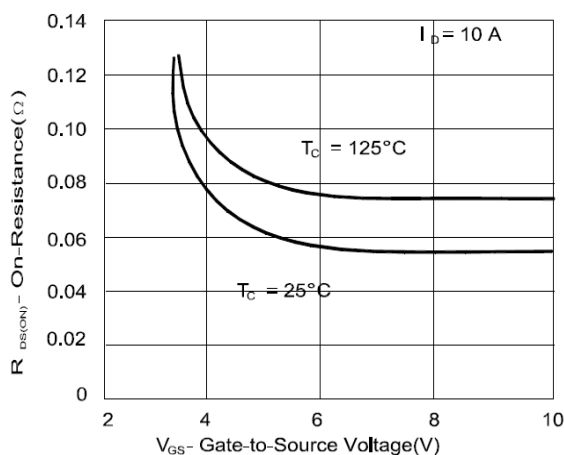

Figure 5: Capacitance Characteristics

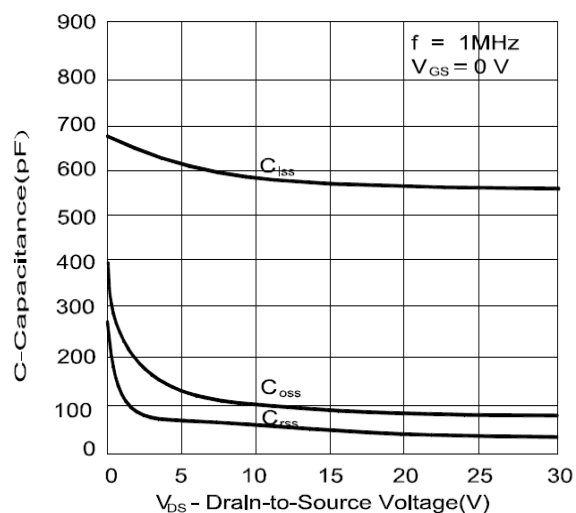

Figure 6: Gate Charge Characteristics

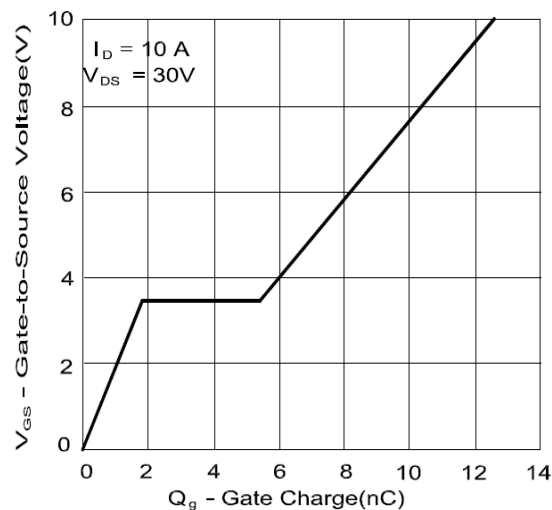

Figure 7: On-Resistance Variation vs. Temperature

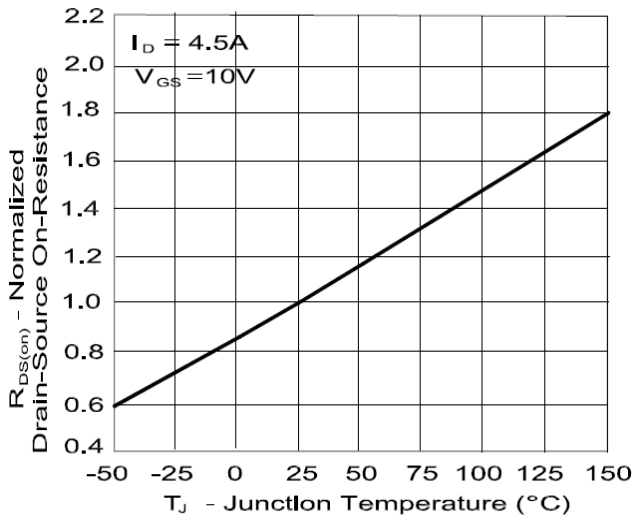

Figure 8: Body Diode Forward Voltage

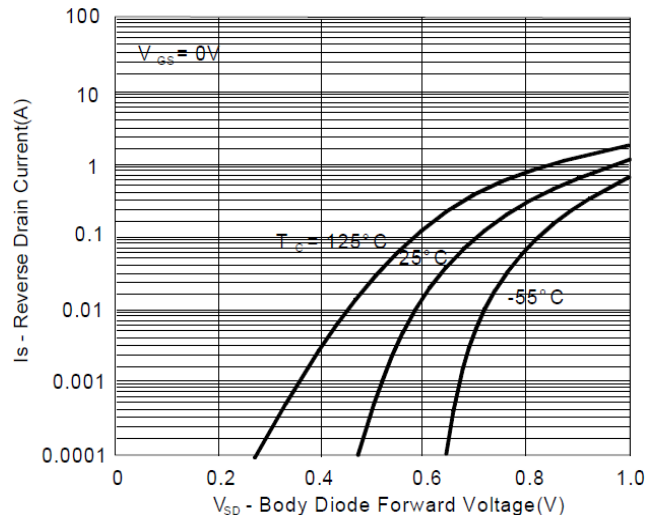

Figure 9: Maximum Safe Operating Area

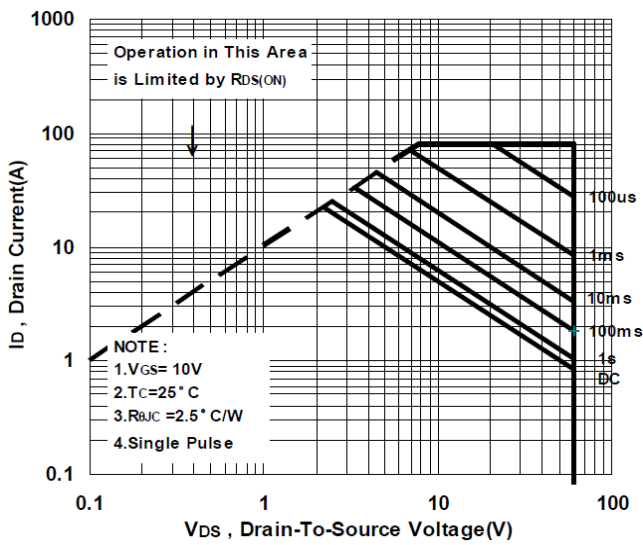

Figure 10: Pulse Maximum Power Dissipation

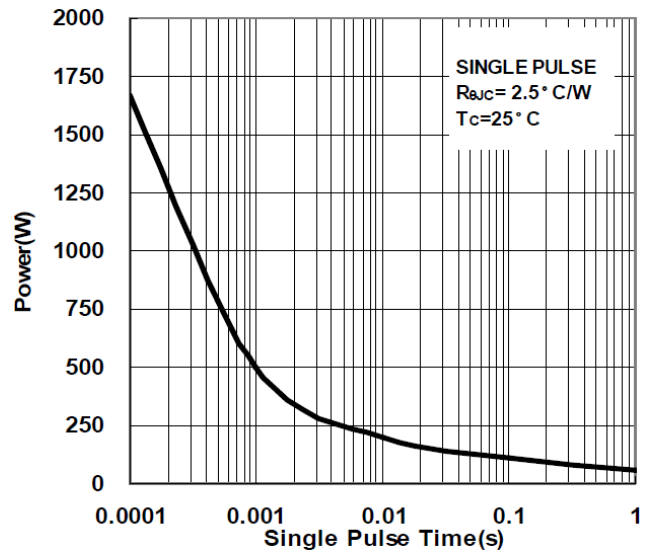
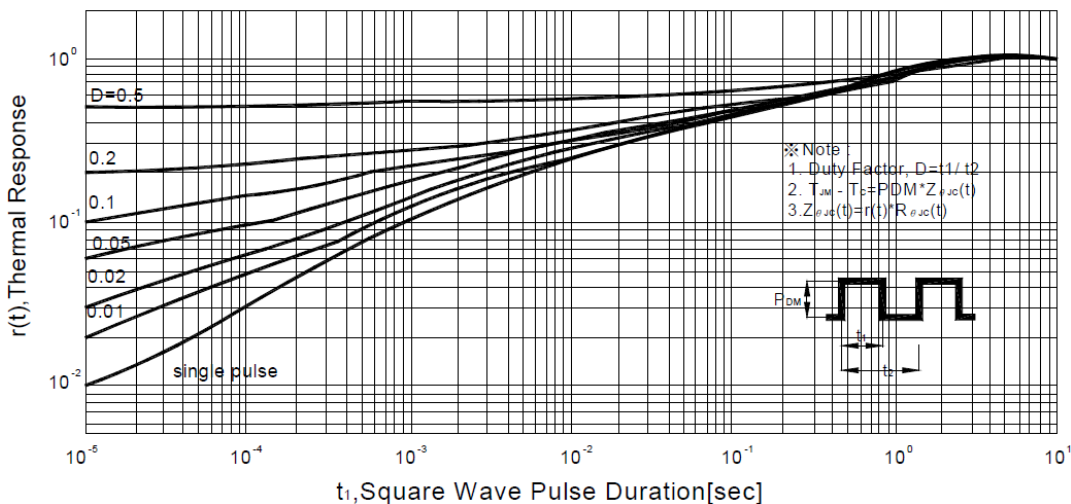
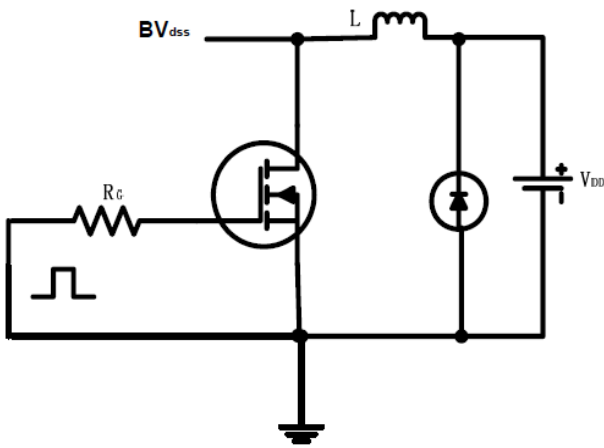

Figure 11: Transient Thermal Response Curve



Test circuits and Waveforms

EAS test circuits:



Gate charge test circuit:

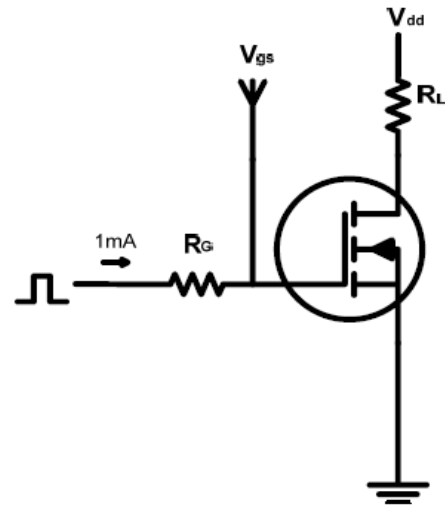

Switch Time Test Circuit:

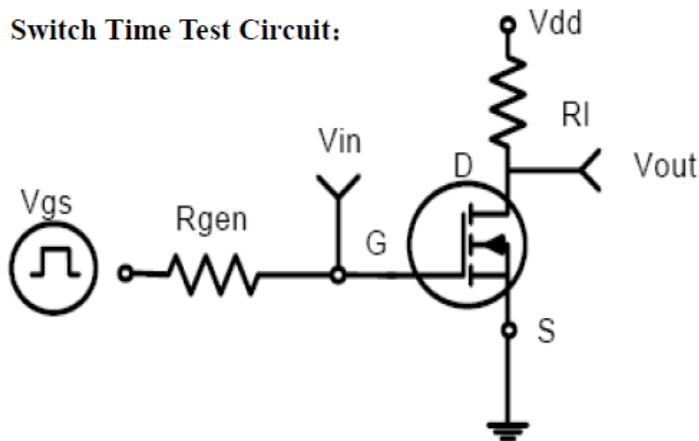

Switch Waveforms:

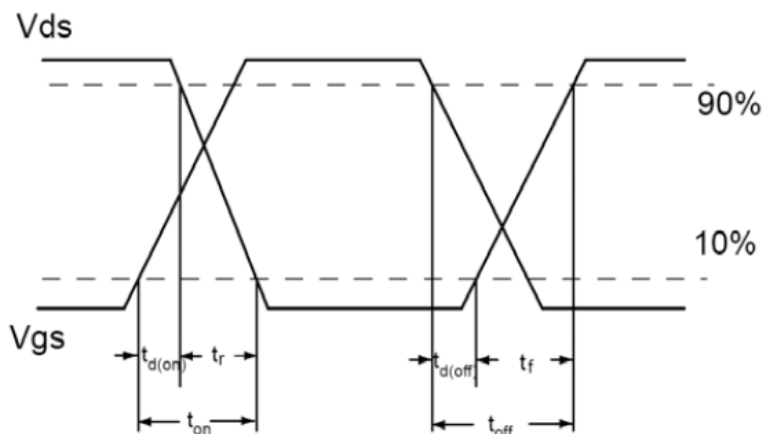

PACKAGE MECHANICAL DATA
TO-252 Package Dimension

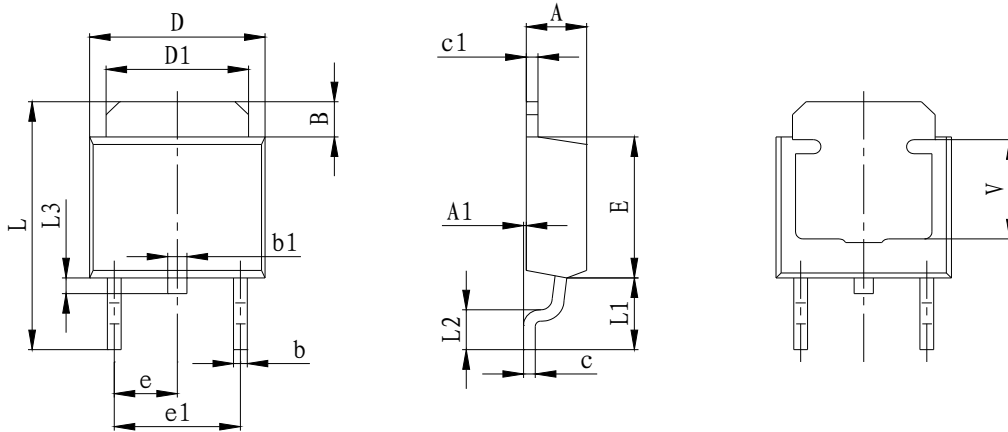

Symbol	Dimensions In Millimeters		Dimensions In Inches	
	Min.	Max.	Min.	Max.
A	2.200	2.400	0.087	0.094
A1	0.000	0.127	0.000	0.005
B	1.350	1.650	0.053	0.065
b	0.500	0.700	0.020	0.028
b1	0.700	0.900	0.028	0.035
c	0.430	0.580	0.017	0.023
c1	0.430	0.580	0.017	0.023
D	6.350	6.650	0.250	0.262
D1	5.200	5.400	0.205	0.213
E	5.400	5.700	0.213	0.224
e	2.300 TYP.		0.091 TYP.	
e1	4.500	4.700	0.177	0.185
L	9.500	9.900	0.374	0.390
L1	2.550	2.900	0.100	0.114
L2	1.400	1.780	0.055	0.070
L3	0.600	0.900	0.024	0.035
V	3.800 REF.		0.150 REF.	