

N-Channel Enhancement Mode Field Effect Transistor

PRODUCT SUMMARY

V_{DSS}	I_D	$R_{DS(ON)}$ (m Ω)
40V	252A	2.0m Ω

Features:

- Low Gate Charge for Fast Switching Application
- Low $R_{DS(ON)}$ to Minimize Conductive Loss
- 100% EAS Guaranteed
- Optimized $V_{(BR)DSS}$ Ruggedness
- Lead-Free, RoHS Compliant

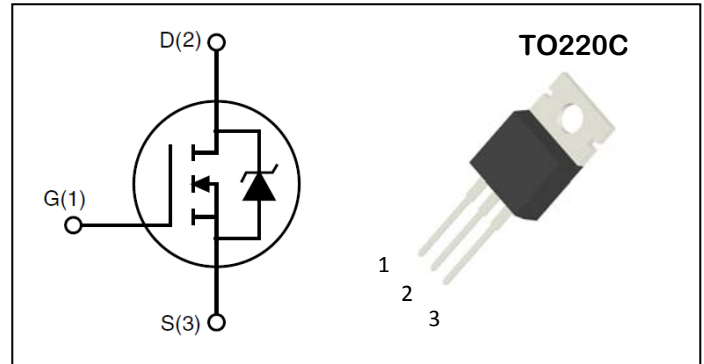

Description:

The ADM250N04 series MOSFETs is a new technology, which combines an innovative super junction technology and advance process. This new technology achieves low $R_{ds(on)}$, energy saving, high reliability and uniformity, superior power density and space saving.

Absolute Maximum Ratings ($T_A = 25^\circ\text{C}$ unless otherwise specified)

Symbol	Parameter		Ratings	Unit
Common Ratings				
V_{DSS}	Drain-Source Voltage		40	V
V_{GSS}	Gate-Source Voltage		± 20	
T_J	Maximum Junction Temperature		175	$^\circ\text{C}$
T_{STG}	Storage Temperature Range		-55 to 175	$^\circ\text{C}$
I_S	Diode Continuous Forward Current	$T_C = 25^\circ\text{C}$	252	A
Mounted on Large Heat Sink				
I_{DM}	300 μs Pulse Drain Current Tested ⁽²⁾	$T_C = 25^\circ\text{C}$	1009	A
I_D	Continuous Drain Current ⁽¹⁾	Silicon Limited	252	A
		Package Limited	80	A
P_D	Maximum Power Dissipation	$T_C = 25^\circ\text{C}$	242	W

Thermal Characteristics

Symbol	Parameter	Ratings	Unit
R_{thJC}	Thermal resistance junction-case max ⁽¹⁾	0.62	$^\circ\text{C}/\text{W}$
R_{thJA}	Thermal resistance junction-ambient max ⁽¹⁾	62	$^\circ\text{C}/\text{W}$

Electrical Characteristics (TA=25°C Unless Otherwise Noted)

Symbol	Parameter	Test conditions	Min.	Typ.	Max.	Unit
On/off Characteristics						
V _{(BR)DSS}	Drain-Source Breakdown Voltage	V _{GS} =0V, I _{DS} =250uA	40	--	--	V
I _{DSS}	Zero Gate Voltage Drain Current	V _{DS} =32V, V _{GS} =0V, T _J =25°C	--	--	1	uA
		V _{DS} =32V, V _{GS} =0V, T _J =125°C	--	--	100	
V _{GS(th)}	Gate Threshold Voltage	V _{DS} =V _{GS} , I _{DS} =250uA	2		4	V
I _{GSS}	Gate Leakage Current	V _{GS} =±20V, V _{DS} =0V	--	--	±100	nA
R _{DS(ON)}	Drain-Source On-state Resistance ⁽²⁾	V _{GS} =10V, I _{DS} =80A	--	1.6	2.0	mΩ
Dynamic Characteristics						
C _{iss}	Input Capacitance	V _{GS} =0V, V _{DS} =20V, Frequency=1MHz	--	8187.6	--	pF
C _{oss}	Output Capacitance		--	1182.8	--	
C _{rss}	Reverse Transfer Capacitance		--	651.6	--	
Switching Characteristics						
t _{d(ON)}	Turn-on Delay Time	V _{DS} =20V, I _D =40A, V _{GS} =10V, R _{GEN} =10Ω	--	30.7	--	ns
t _r	Turn-on Rise Time		--	81.1	--	
t _{d(OFF)}	Turn-off Delay Time		--	185.7	--	
t _f	Turn-off Fall Time		--	91.3	--	
Q _g	Total Gate Charge	V _{DS} =20V, V _{GS} =10V, I _{DS} =80A	--	136.3	--	nC
Q _{gs}	Gate-Source Charge		--	36	--	
Q _{gd}	Gate-Drain Charge		--	23.4	--	
Avalanche Characteristics						
EAS	Single Pulse Avalanche Energy ⁽³⁾	V _{DD} =20V, L=1mH, V _{GS} =10V, R _g =25Ω	200	--	--	mJ
Diode Characteristics						
V _{SD}	Diode Forward Voltage ⁽²⁾	I _{SD} =80A, V _{GS} =0	--	--	1.2	V
t _{rr}	Reverse Recovery Time	I _{SD} =80A, dI _{SD} /dt=100A/μs	--	69.3	--	ns
q _{rr}	Reverse Recovery Charge		--	66.2	--	nC

NOTES:

- 1.The data tested by surface mounted on a 1 inch² FR-4 board with 20Z copper.
- 2.The data tested by pulsed , pulse width ≤ 300us , duty cycle ≤ 2%
- 3.The Min. value is 100% EAS tested guarantee.

Typical Performance Characteristics

Figure 1: On-Region Characteristics

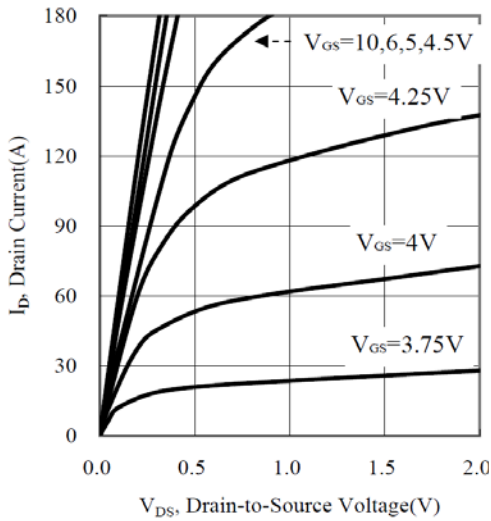

Figure 2: Power Dissipation

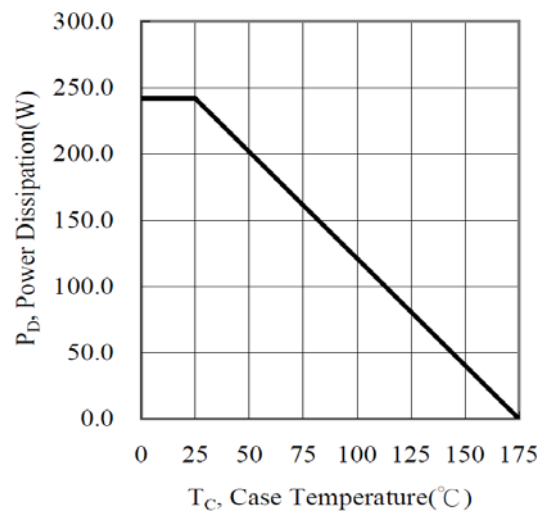

Figure 3: Drain Current

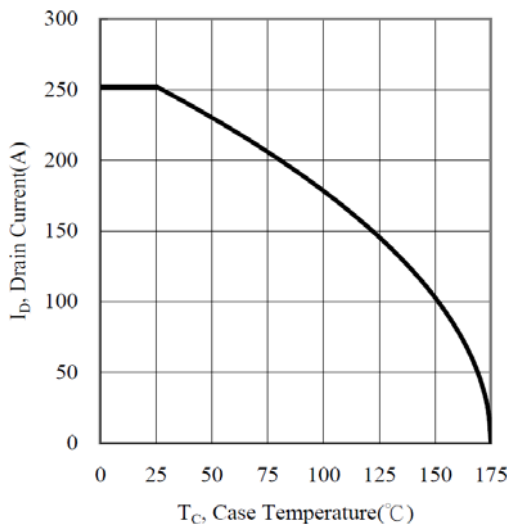

Figure 4: Drain-to-Source Breakdown Voltage

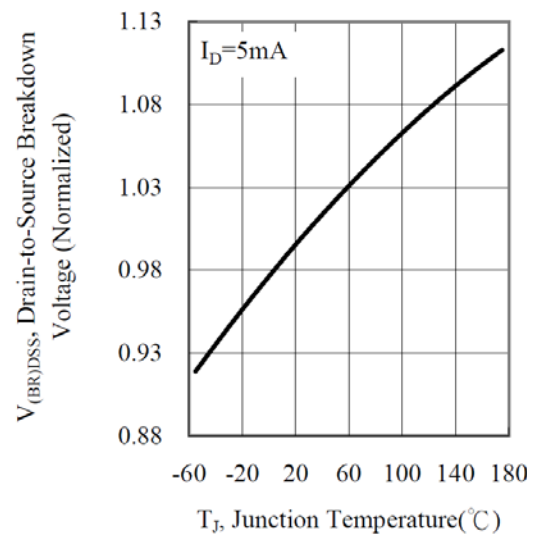

Figure 5: Capacitance Characteristics

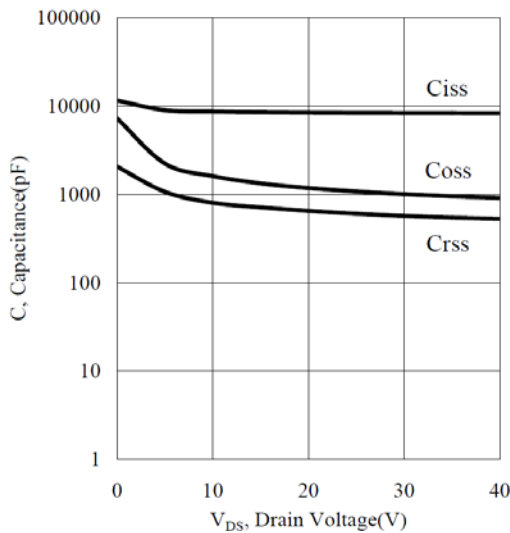

Figure 6: Gate Charge Characteristics

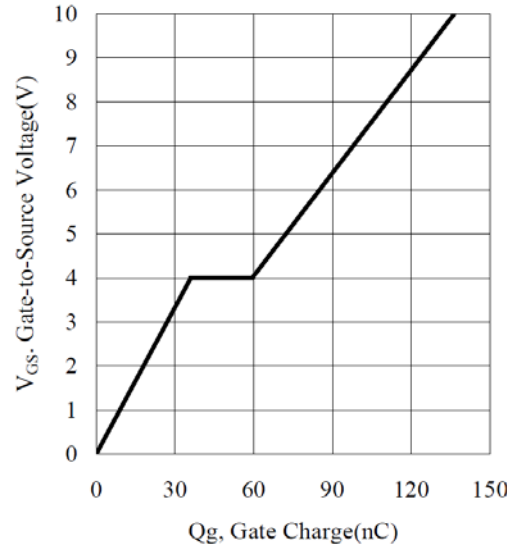

Figure 7: Gate Threshold Voltage

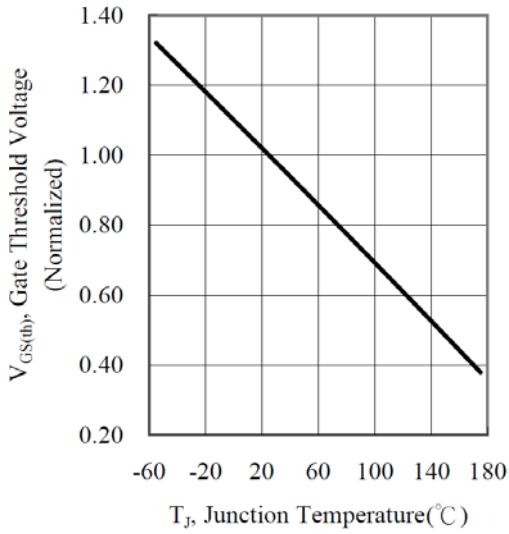

Figure 8: Drain-to-Source On-Resistance

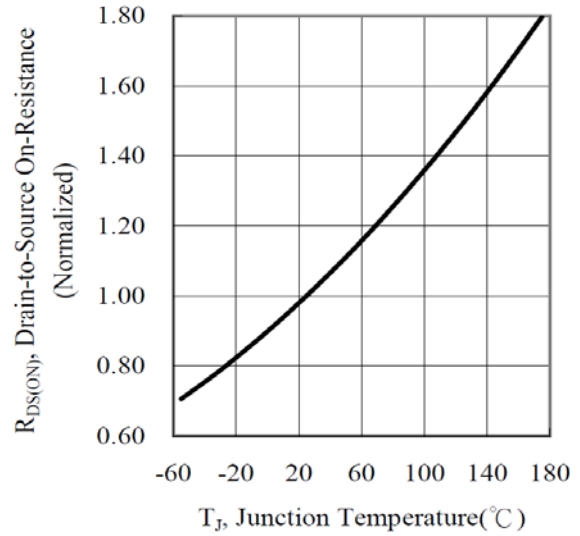

Figure 9: Avalanche Characteristics

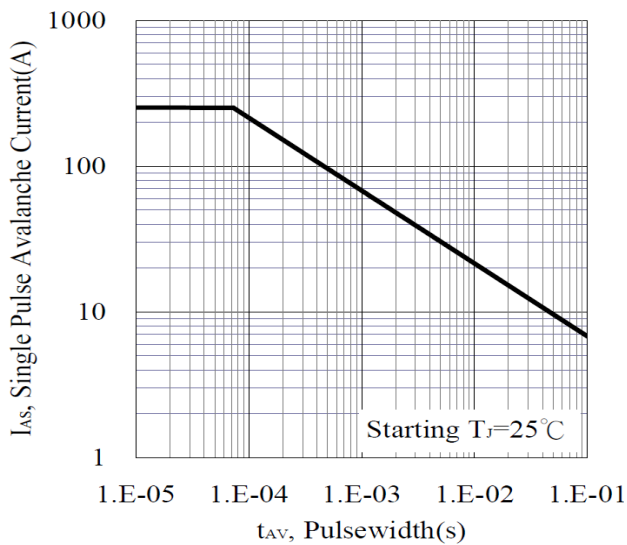
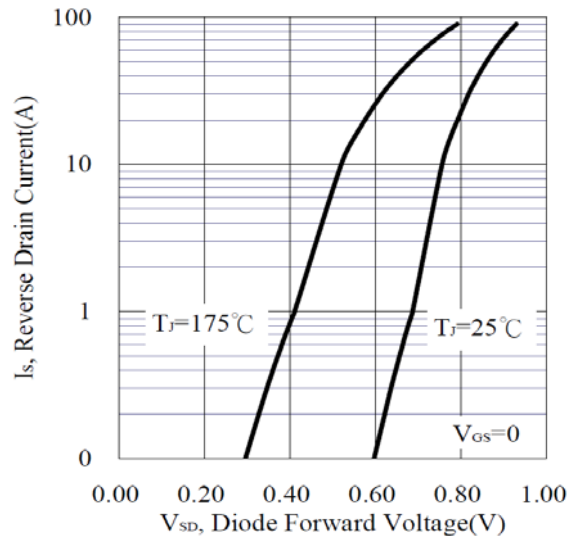
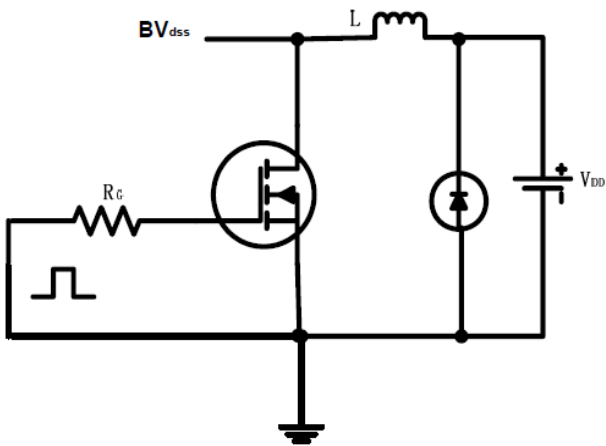

Figure 10: Forward Characteristics of reverse diode



Test circuits and Waveforms

EAS test circuits:



Gate charge test circuit:

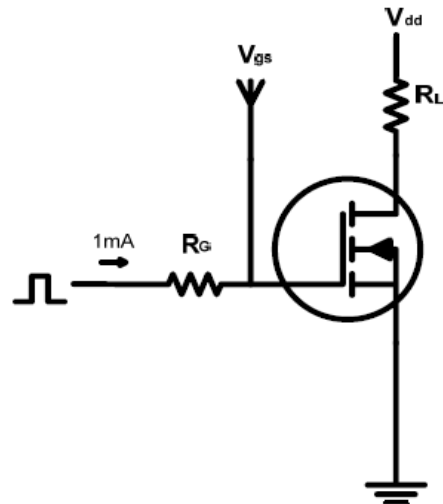

Switch Time Test Circuit:

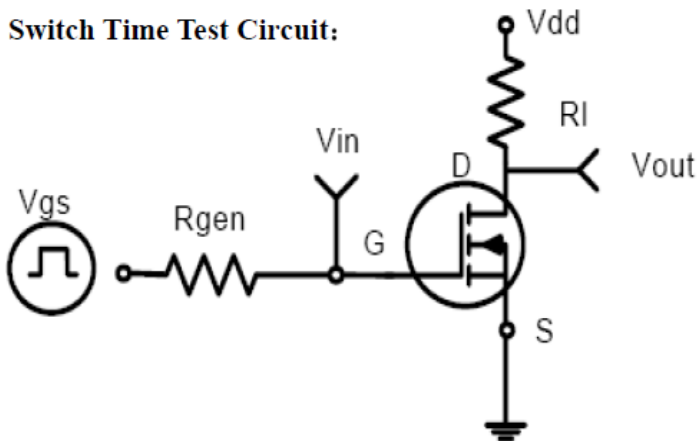

Switch Waveforms:

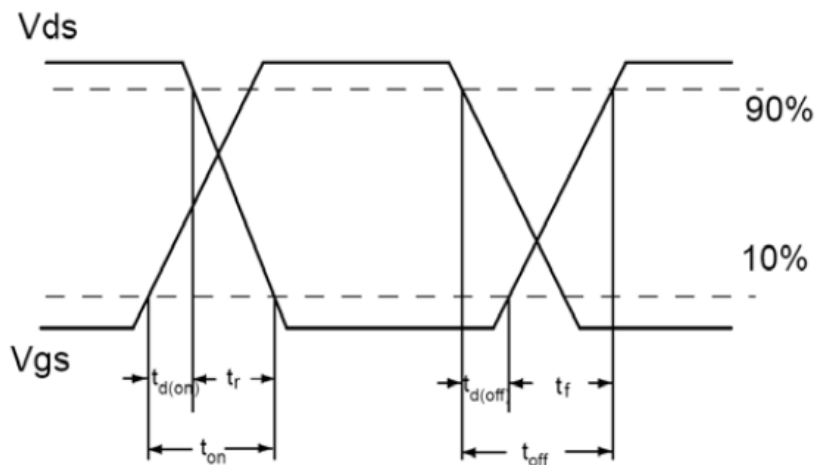

PACKAGE MECHANICAL DATA
TO-220C Package Dimension

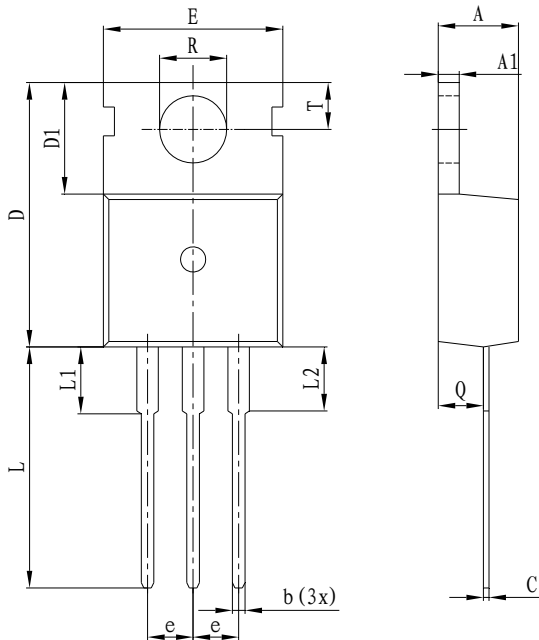

Symbol	Dimensions In Millimeters		Dimensions In Inches	
	Min	Max	Min	Max
e	2.54 TYP		0.099TYP	
A	4.10	4.70	0.161	0.185
A1	1.25	1.40	0.049	0.055
b	0.60	0.90	0.023	0.035
C	0.40	0.70	0.016	0.027
D	15.20	16.00	0.598	0.630
D1	5.90	6.60	0.232	0.259
E	9.70	10.30	0.382	0.405
L	12.80	15.00	0.504	0.590
L1	2.79	3.30	0.110	0.130
R	3.50	3.80	0.138	0.149
T	2.70	3.00	0.106	0.118
Q	2.20	2.60	0.086	0.102
L2		3.00		0.118

Ordering information

Part number	Package	Marking	Packing	Quantity
ADM250N04	TO-220C	ADM250N04	Tube	50pcs