ADNS-3050**ADNS-3050 Entry-level Gaming Optical Navigation Sensor**

Data Sheet**Description**

The Pixart ADNS-3050 is a small form factor entry-level gaming optical navigation sensor. It is housed in an 8-pin staggered dual in-line package (DIP). It is capable of high-speed motion detection typically at 60ips and acceleration up to 20g; suitable for both wired and wireless gaming navigation system. The low power management in wireless mode can be customized to suit user preferences. In addition, it has an on-chip oscillator and LED driver to minimize external components.

The ADNS-3050 sensor along with the ADNS-5110-001 lens, ad36@EŽ #\$\$ Ž" "\$ trim WeLED clip, and HLMP-EG3E red LED forms a complete and compact mouse tracking system. There are no moving parts, which translates to high reliability and less maintenance for the end user. Precision optical alignment is not required, thus facilitating high volume assembly.

Theory of Operation

The ADNS-3050 is based on Optical Navigation Technology, which measures changes in position by optically acquiring sequential surface images (frames) and mathematically determining the direction and magnitude of movement. The ADNS-3050 contains an Image Acquisition System (IAS), a Digital Signal Processor (DSP), and a four wire serial port. The IAS acquires microscopic surface images via the lens and illumination system. These images are processed by the DSP to determine the direction and distance of motion. The DSP calculates the ΔX and Δy relative displacement values. An external microcontroller reads and translates the ΔX and Δy information from the sensor serial port into PS2, USB, or RF signals before sending them to the host PC.

Features

- Small Form Factor Package - 8-pin DIP
- Operating Voltage: 2.8V-3.0V
- High Speed Motion Detection at typical of 60ips and acceleration up to 20g.
- Selectable Resolutions up to 2000cpi
- Four wire Serial Port Interface
- External Interrupt Output for Motion Detection
- Internal Oscillator — no clock input needed
- On-chip LED driver
- Minimal number of passive components
- Programmable power-saving modes for selectable wired or wireless application
- Customizable response time and downshift time for rest modes
- Configurable LED operating modes and drive current

Applications

- Wired and Wireless Optical gaming mice and trackballs
- Integrated input devices
- Battery-powered input devices

NOTE: The ADNS-3050 sensor is not designed for use with blue LED navigation system.

Pinout of ADNS-3050 Optical Mouse Sensor

Pin	Name	Input/Output	Description
1	MISO	O	Serial Data Output (Master In/Slave Out)
2	LED	I	LED Illumination Control Input
3	MOTION	O	Motion Interrupt Output (Active low _r)
4	NCS	I	Chip Select (Active low)
5	SCLK	I	Serial Clock Input
6	GND	I	Ground
7	VDD	I	Supply Voltage
8	MOSI	I	Serial Data Input (Master Out/Slave In)

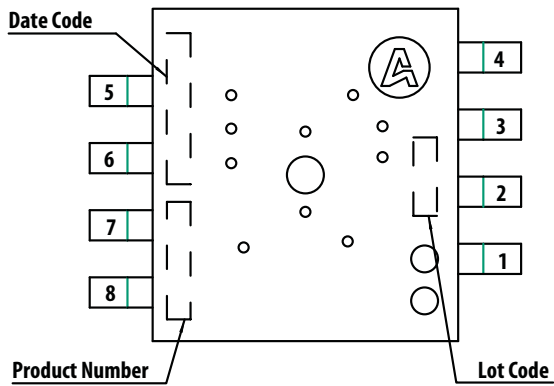

Item	Marking	Remarks
Product Number	A3050	
Date Code	XYWWZ	X = Subcon Code YYWW = Date Code Z = Sensor Die Source
Lot Code	VVV	Numeric

Figure 1. Package Outline Drawing (Top View)

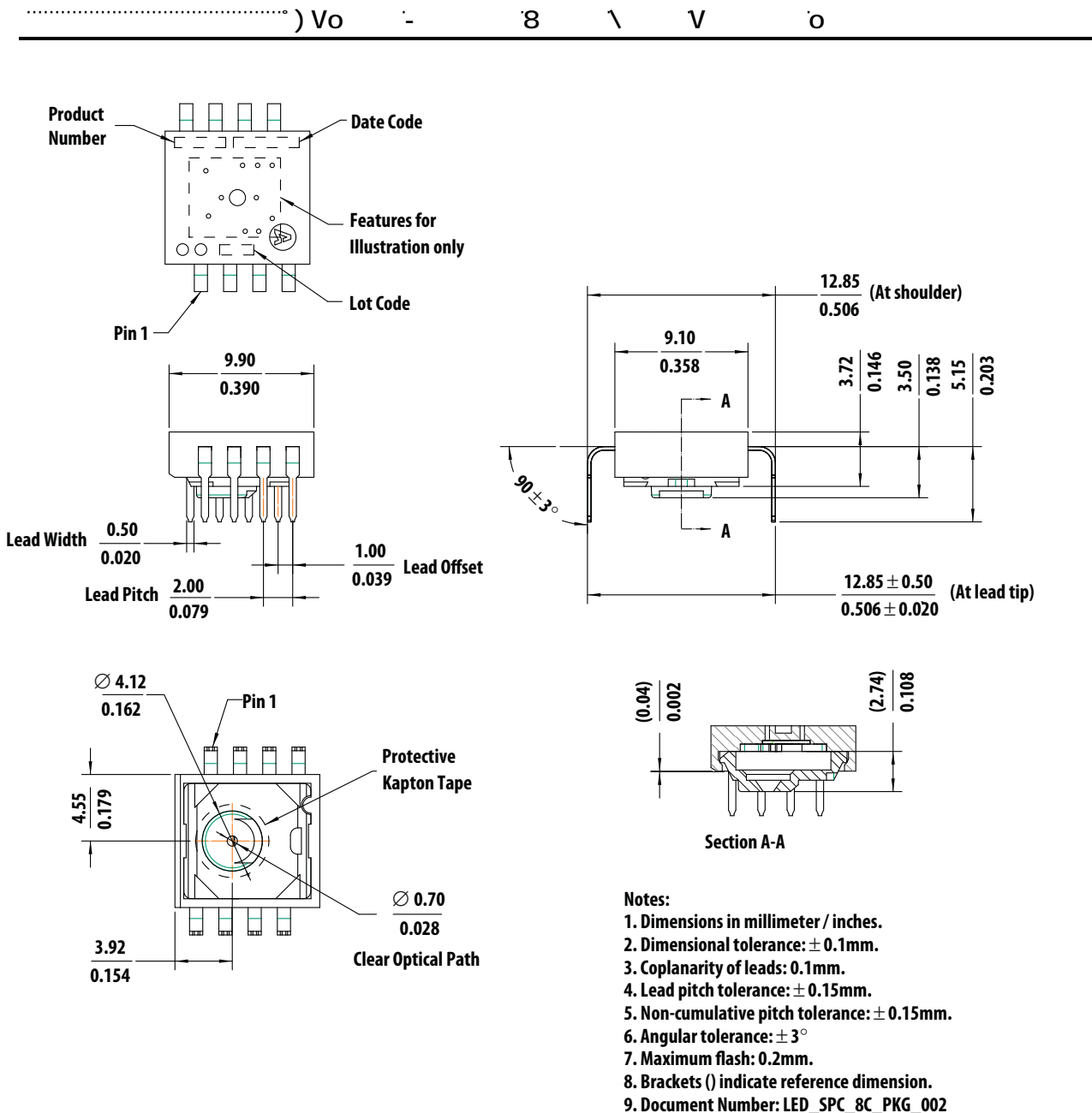
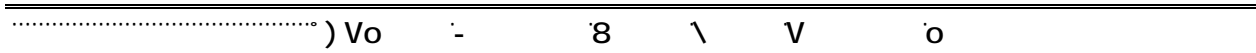

Figure 2. Package Outline Drawing

CAUTION: It is advised that normal static precautions be taken in handling and assembling of this component to prevent damage and/or degradation which may be induced by ESD.



Overview of Optical Mouse Sensor Assembly

Pixart provides an IGES file drawing describing the base plate molding features for lens and PCB alignment. The ADNS-3050 sensor is designed for mounting on a through-hole PCB. There is an aperture stop and features on the package that align to the lens. The ADNS-5110-001 lens S V ADNS-5120-002 trim lens provides optics for the imaging of the surface as well as illumination of the surface at the optimum angle. Features on the lens align it to the sensor, base plate, and clip with the LED. The LED clip holds the LED in relation to the lens. The LED must be inserted into the clip and the LED's leads formed prior to loading on the PCB.

The HLMP-EG3E red LED is recommended for illumination.

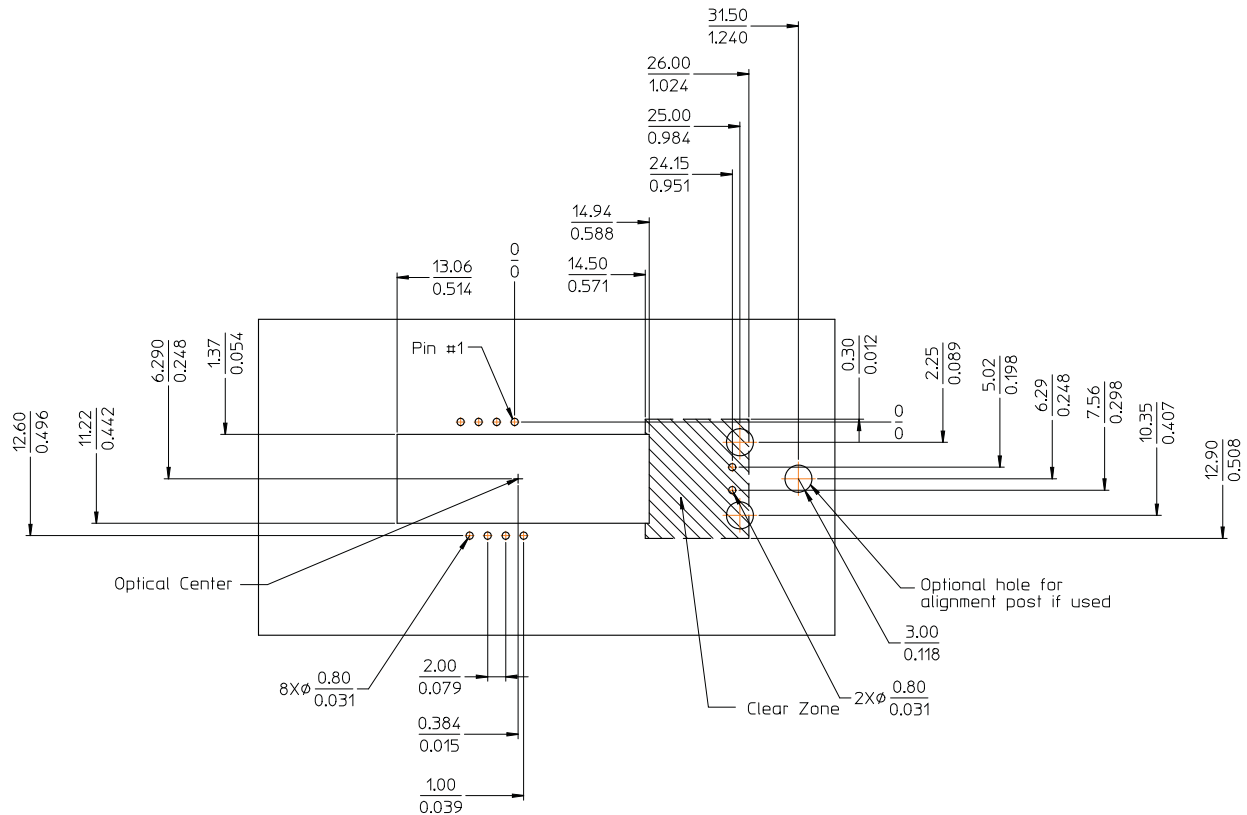

- Notes:
1. Dimensions in millimeter/inches
 2. View from component side of PCB (or top view of mouse)

Figure 3. Recommended PCB Mechanical Cutouts and Spacing

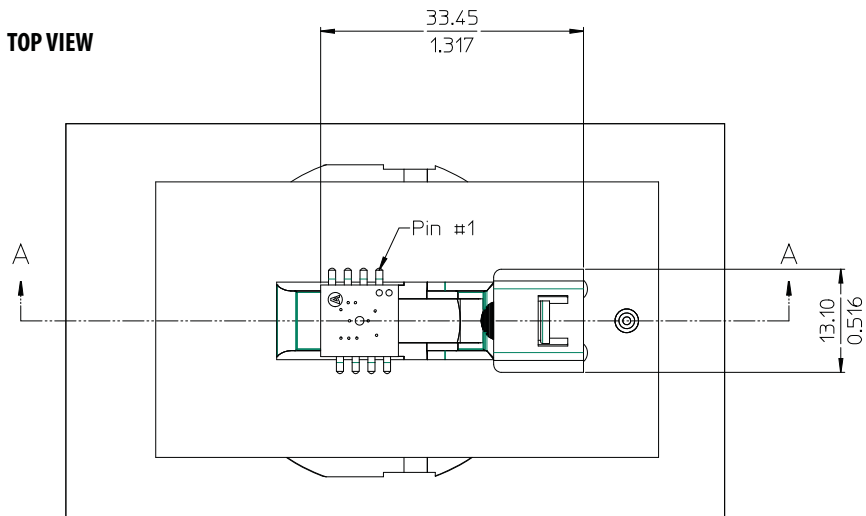

CROSS SECTION SIDEVIEW

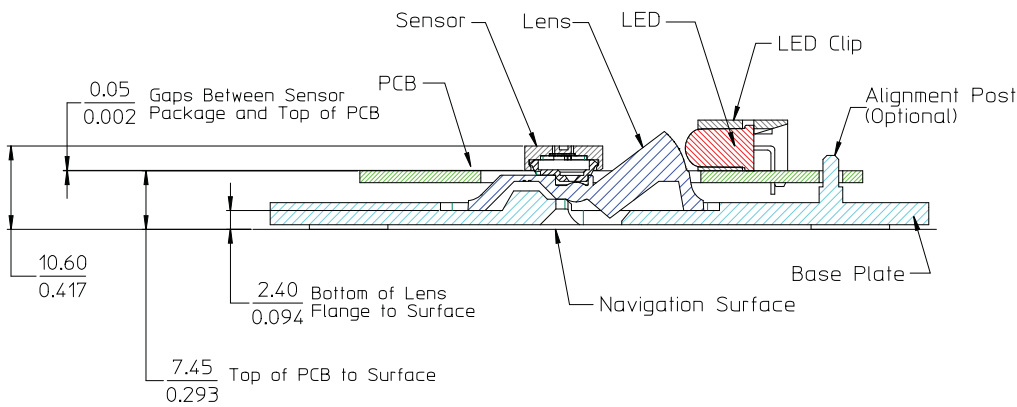

NOTE: Dimensions in mm/inches.
Important Note: Pin 1 of sensor should be located nearest to the LED.

Important Note: Pin 1 of sensor should be located nearest to the LED

Figure 4. 2D Assembly drawing of ADNS-3050 (Top and Side View)

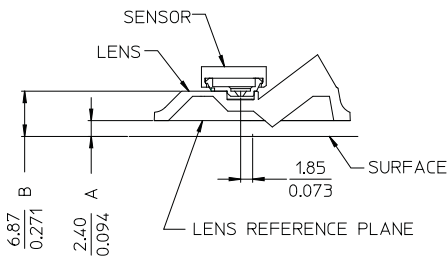

Note:
A – Distance from object surface to lens reference plane
B – Distance from object surface to sensor reference plane

Figure 5. Distance from lens reference plane to tracking surface (Z)

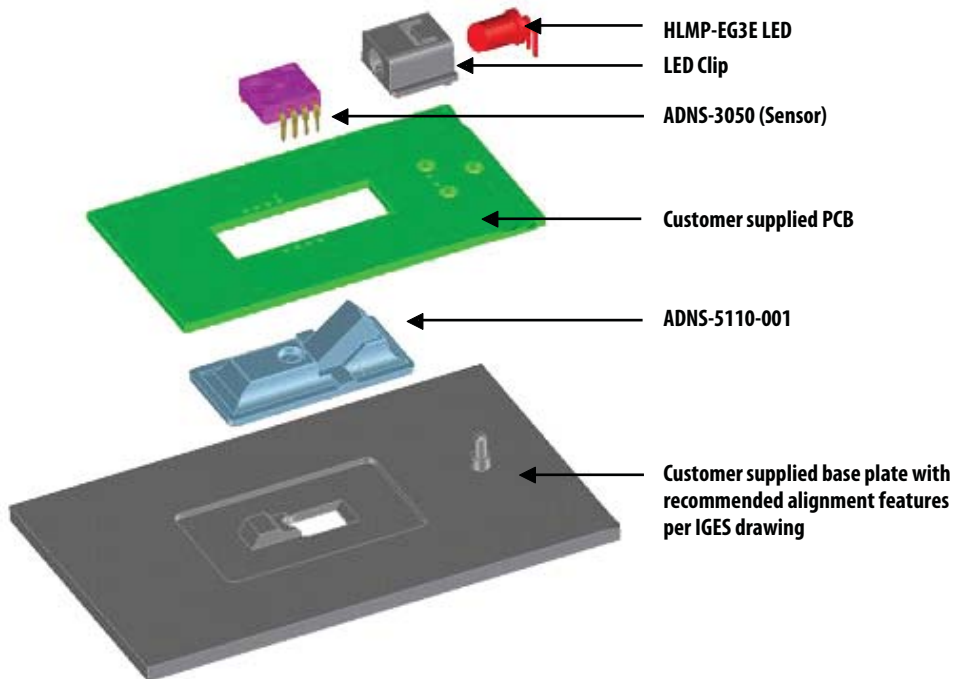
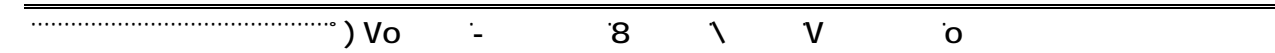

Important Note: IR LED is recommended for lower power consumption.

Figure 6. Exploded View of Assembly

PCB Assembly Considerations

1. Insert the sensor and all other electrical components into PCB.
2. Insert the LED into the assembly clip and bend the leads 90 degrees.
3. Insert the LED clip assembly into PCB.
4. This sensor package is only qualified for wave-solder process.
5. Wave solder the entire assembly in a no-wash solder process utilizing solder fixture. The solder fixture is needed to protect the sensor during the solder process. It also sets the correct sensor-to-PCB distance as the lead shoulders do not normally rest on the PCB surface. The fixture should be designed to expose the sensor leads to solder while shielding the optical aperture from direct solder contact.
6. Place the lens onto the base plate.
7. Remove the protective Kapton tape from optical aperture of the sensor. Care must be taken to keep contaminants from entering the aperture. Recommend not to place the PCB facing up during the entire mouse assembly process. Recommend to hold the PCB first vertically for the Kapton removal process.
8. Insert PCB assembly over the lens onto the base plate aligning post to retain PCB assembly. The sensor aperture ring should self-align to the lens.
9. The optical position reference for the PCB is set by the base plate and lens. Note that the PCB motion due to button presses must be minimized to maintain optical alignment.
10. Install mouse top case. There MUST be a feature in the top case to press down onto the PCB assembly to ensure all components are interlocked to the correct vertical height.

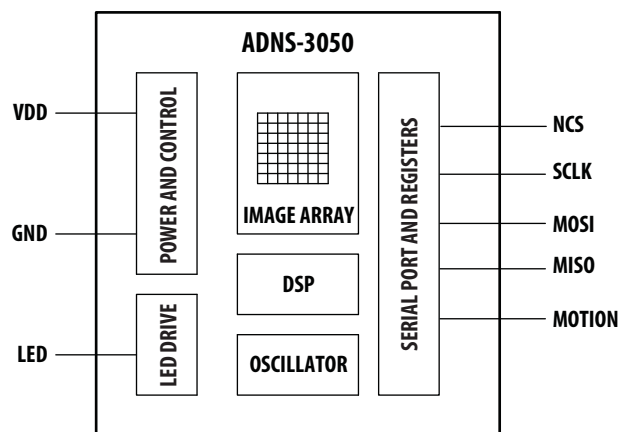

Figure 7. Block diagram of ADNS-3050 optical mouse

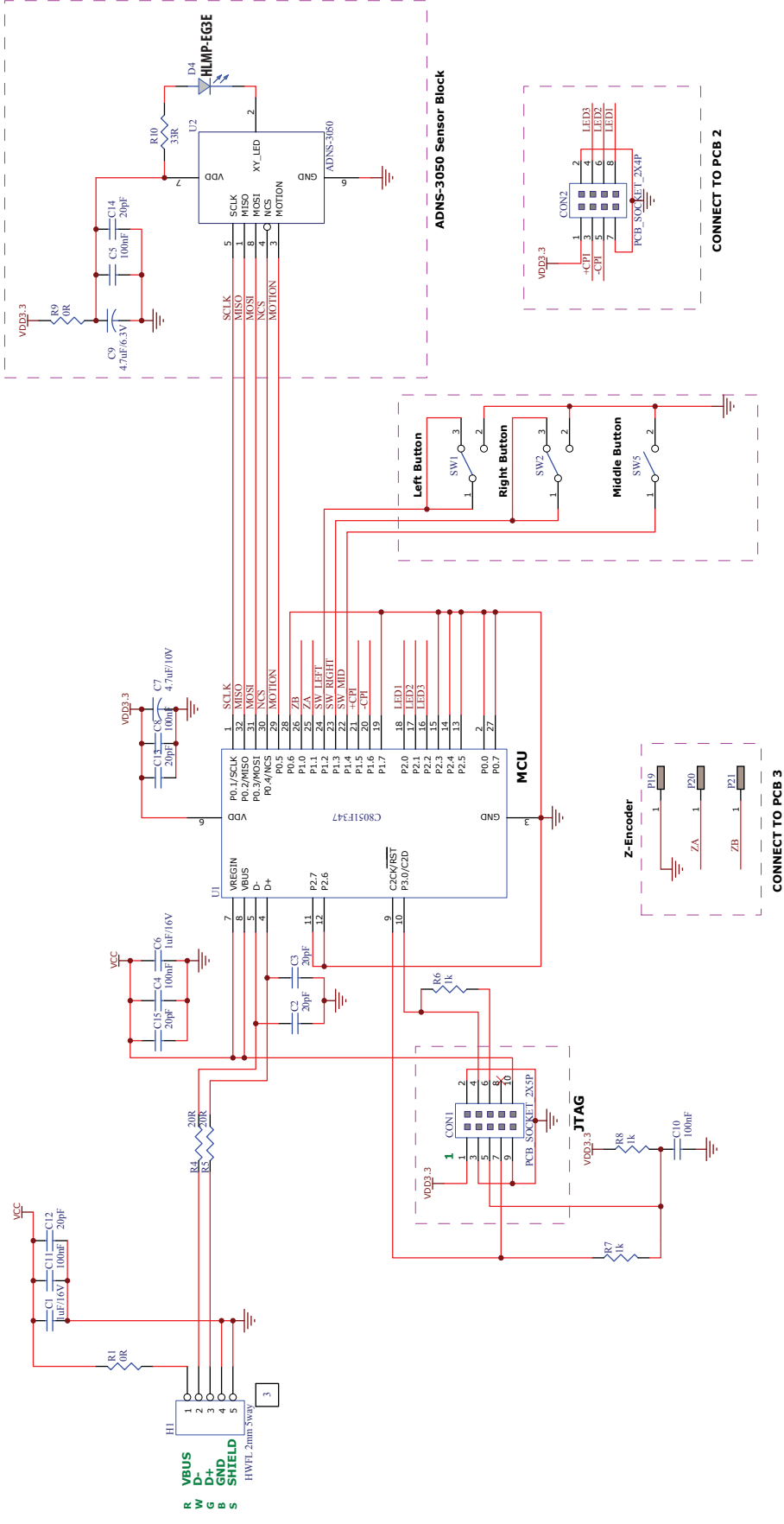

Figure 8. Schematic diagram for interface between ADNS-3050 and microcontroller with HLMPEG3E Red LED on a corded solution
 NOTE: The ADNS-3050 Optical Mouse Sensor is not designed for use with blue LED navigation system.

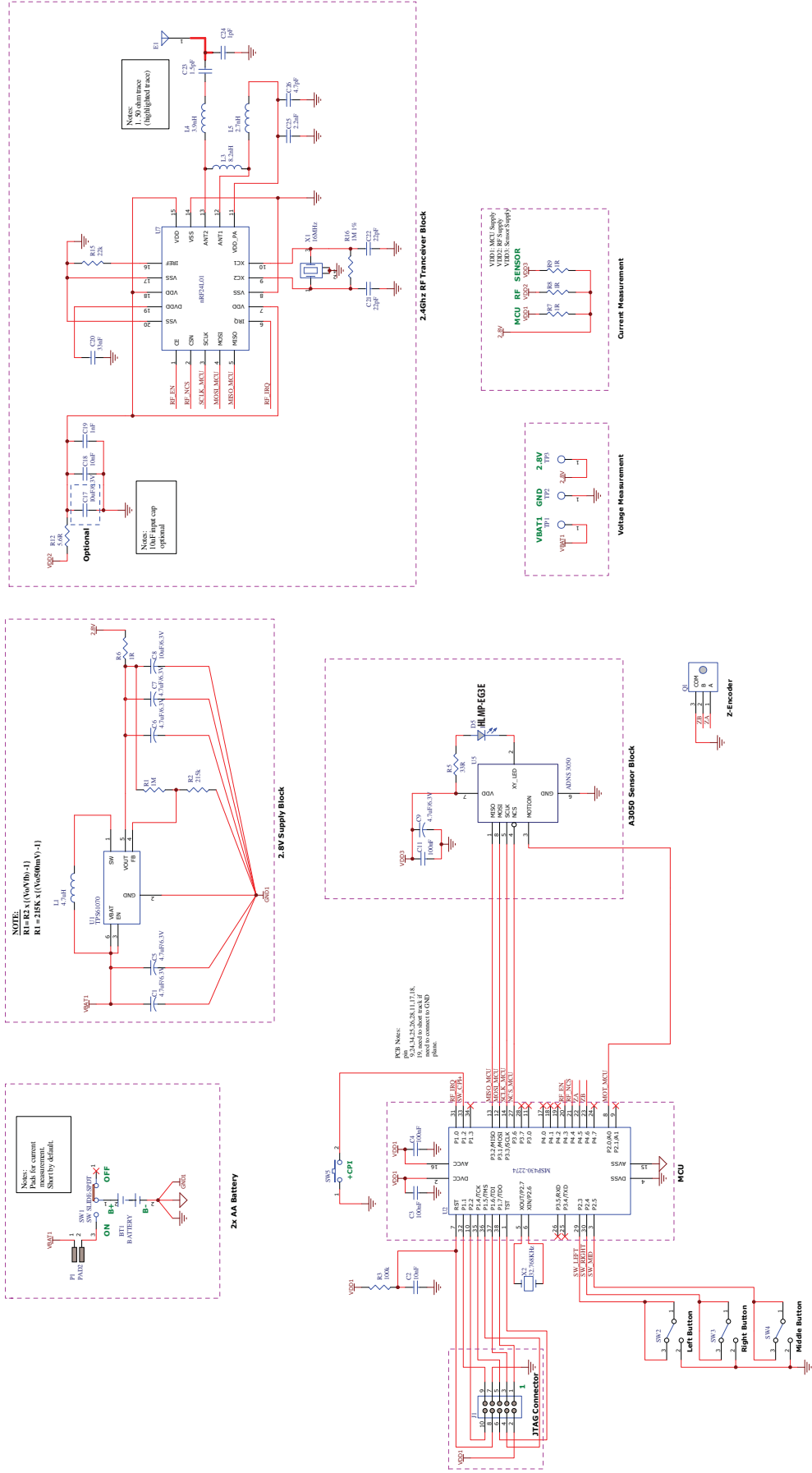
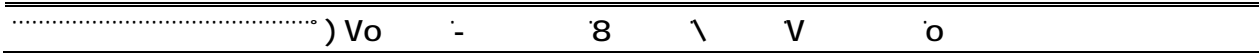

Figure 9. Schematic diagram for interface between ADNS-3050 and microcontroller with HLMPEG3E Red LED on a wireless solution
 NOTE: The ADNS-3050 Optical Mouse Sensor is not designed for use with blue LED navigation system.



Design Considerations for Improved ESD Performance

For improved electrostatic discharge performance, typical creepage and clearance distance are shown in the table below. Assumption: base plate construction is as per the Pixart supplied IGES file and ADNS-5110-001 or ADNS-5120-002 trim lens. Note that the lens material is polycarbonate or polystyrene HH30. Therefore, cyanoacrylate based adhesives or other adhesives that may damage the lens should NOT be used.

ADNS-5110-001 Lens	Typical Distance (mm)
Creepage	15.43
Clearance	7.77

Regulatory Requirements

- Passes FCC B and worldwide analogous emission limits when assembled into a mouse with shielded cable and following Pixart’s recommendations.
- Passes IEC-1000-4-3 radiated susceptibility level when assembled into a mouse with shielded cable and following Pixart’s recommendations.
- Passes EN61000-4-4/IEC801-4 EFT tests when assembled into a mouse with shielded cable and following Pixart recommendations.
- Provides sufficient ESD creepage/clearance distance to withstand discharge up to 15KV when assembled into a mouse according to usage instructions above.

Table 1. Absolute Maximum Ratings

Parameter	Symbol	Minimum	Maximum	Units	Notes
Storage Temperature	T _S	-40	85	°C	
Operating Temperature	T _A	-15	55	°C	
Lead Solder Temperature	T _{SOLDER}		260	°C	For 7 seconds, 1.6mm below seating plane.
Supply Voltage	V _{DD}	-0.5	3.7	V	
ESD (Human Body Model)			2	kV	All pins
Input Voltage	V _{IN}	-0.5	V _{DD} + 0.5	V	All I/O pins
Output Current	I _{out}		7	mA	MISO pin

Table 2. Recommended Operating Condition

Parameter	Symbol	Min	Typ.	Max	Units	Notes
Operating Temperature	T _A	0		40	°C	
Power Supply Voltage	V _{DD}	2.8		3.0	V	
Power Supply Rise Time	t _{RT}	0.005		100	ms	0 to V _{DD} min
Supply Noise (Sinusoidal)	V _{NA}			100	mVp-p	10kHz —50MHz
Serial Port Clock Frequency	f _{SCLK}			1	MHz	50% duty cycle
Distance from Lens Reference Plane to Tracking Surface	Z	2.3	2.4	2.5	mm	
Speed	S		60		ips	
Acceleration	A			20	g	In run mode
Load Capacitance	C _{out}			100	pF	MISO

Table 3. AC Electrical Specifications

Electrical characteristics over recommended operating conditions. Typical values at 25 °C, VDD = 2.8 V.

Parameter	Symbol	Min.	Typ.	Max.	Units	Notes
Motion Delay after Reset	t _{MOT-RST}			50	ms	From RESET register write to valid motion
Power Down	t _{PD}			50	ms	From PD active to low current
Wake from Power Down	t _{WAKEUP}	50		55	ms	From PD inactive to valid motion (when write 0x5a to register 0x3a)
MISO Rise Time	t _{r-MISO}		40	200	ns	CL = 100 pF
MISO Fall Time	t _{f-MISO}		40	200	ns	CL = 100 pF
MISO Delay after SCLK	t _{DLY-MISO}			120	ns	From SCLK falling edge to MISO data valid, no load condition
MISO Hold Time	t _{hold-MISO}	500		1/fSCLK	ns	Data held until next falling SCLK edge
MOSI Hold Time	t _{hold-MOSI}	200			ns	Amount of time data is valid after SCLK rising edge
MOSI Setup Time	t _{setup-MOSI}	120			ns	From data valid to SCLK rising edge
SPI Time between Write Commands	t _{SWW}	30			μs	From rising SCLK for last bit of the first data byte, Commands to rising SCLK for last bit of the second data byte
SPI Time between Write and Read Command	t _{SWR}	20			μs	From rising SCLK for last bit of the first data byte, to rising SCLK for last bit of the second address byte
SPI Time between Read and Subsequent Commands	t _{SRW} t _{SRR}	250			ns	From rising SCLK for last bit of the first data byte, to falling SCLK for the first bit of the next address
SPI Read Address-Data Delay	t _{SRAD}	4			μs	From rising SCLK for last bit of the address byte, to falling SCLK for first bit of data being read
NCS to SCLK Active	t _{NCS-SCLK}	120			ns	From NCS falling edge to first SCLK falling edge
SCLK to NCS Inactive (for Read Operation)	t _{SCLK-NCS}	120			ns	From last SCLK rising edge to NCS rising edge, for valid MISO data transfer
SCLK to NCS Inactive (for Write Operation)	t _{SCLK-NCS}	20			μs	From last SCLK rising edge to NCS rising edge, for valid MOSI data transfer
NCS to MISO high-Z	t _{NCS-MISO}			250	ns	From NCS rising edge to MISO high-Z state
Transient Supply Current	I _{DDT}			60	mA	Max supply current during a VDD ramp from 0 to VDD

Table 4. DC Electrical Specifications

Electrical characteristics over recommended operating conditions. Typical values at 25° C, VDD_{LED} = 2.8 V, IRLED HLMP-EG3E, R_{LED} = 33 Ω.

Parameter	Symbol	Min	Typ.	Max	Units	Notes
DC Supply Current	I _{DD_RUN_DC}		26.604		mA	Including LED current.
	I _{DD_RUN_WIRELESS}		14.236			No load on MISO
	I _{DD_REST1}		0.817			Default sensor setting for Rest 1,
	I _{DD_REST2}		0.105			Rest 2 and Rest 3 modes
	I _{DD_REST3}		0.022			
Power Down Current	I _{PD}		10		μA	
Input Low Voltage	V _{IL}			0.5	V	SCLK, MOSI, NCS
Input High Voltage	V _{IH}	V _{DD} -0.5			V	SCLK, MOSI, NCS
Input Hysteresis	V _{L_HYS}		200		mV	SCLK, MOSI, NCS
Input Leakage Current	I _{leak}		±1	±10	μA	V _{in} =V _{DD} -0.6V, SCLK, MOSI, NCS
Output Low Voltage	V _{OL}			0.7	V	I _{out} =1mA, MISO, MOTION
Output High Voltage	V _{OH}	V _{DD} -0.7			V	I _{out} =-1mA, MISO, MOTION
Input Capacitance	C _{in}		50		pF	MOSI, NCS, SCLK

Synchronous Serial Port

The synchronous serial port is used to set and read parameters in the ADNS-3050, and to read out the motion information. The port is a four wire serial port. The host micro-controller always initiates communication; the ADNS-3050 never initiates data transfers. SCLK, MOSI, and NCS may be driven directly by a micro-controller. The port pins may be shared with other SPI slave devices. When the NCS pin is high, the inputs are ignored and the output is at tri-state.

The lines that comprise the SPI port:

SCLK: Clock input. It is always generated by the master (the micro-controller).

MOSI: Input data. (Master Out/Slave In)

MISO: Output data. (Master In/Slave Out)

NCS: Chip select input (active low). NCS needs to be low to activate the serial port; otherwise, MISO will be high Z, and MOSI & SCLK will be ignored. NCS can also be used to reset the serial port in case of an error.

Chip Select Operation

The serial port is activated after NCS goes low; otherwise, MISO will be high-Z, while MOSI and SCLK will be ignored. If NCS is raised during a transaction, the entire transaction is aborted and the serial port will be reset. This is true for all transactions. After a transaction is aborted, the normal address-to-data or transaction-to-transaction delay is still required before beginning the next transaction. To improve communication reliability, all serial transactions should be framed by NCS. NCS can also be used to reset the serial port in case of an error occurs.

Write Operation

Write operation, defined as data going from the micro-controller to the ADNS-3050, is always initiated by the micro-controller and consists of two bytes. The first byte contains the address (seven bits) and has a "1" as its MSB to indicate write sequence. The second byte contains the data. The ADNS-3050 reads MOSI on rising edges of SCLK.

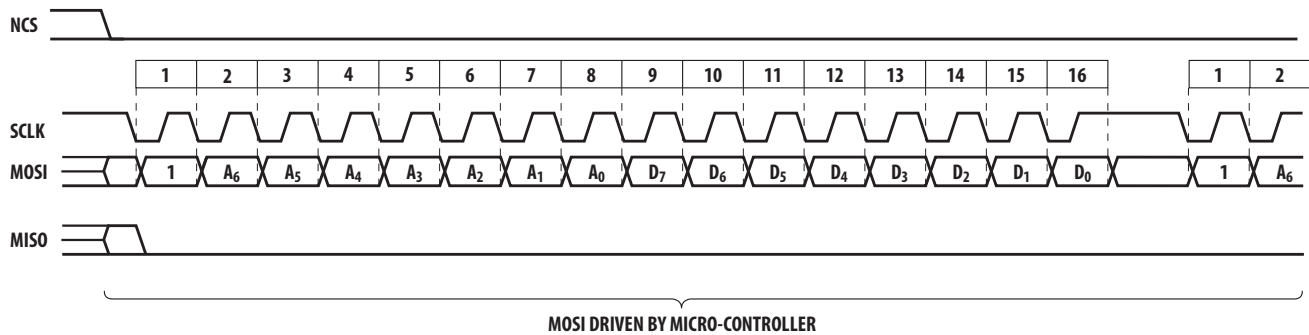

Figure 12. Write Operation

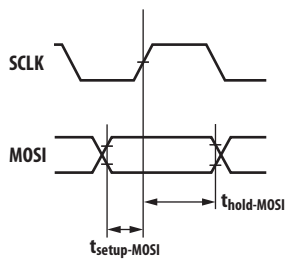

Figure 13. MOSI setup

Read Operation

A read operation, defined as data going from the ADNS-3050 to the micro-controller, is always initiated by the micro-controller and consists of two bytes. The first byte contains the address, is sent by the micro-controller over MOSI, and has a "0" as its MSB to indicate data direction. The second byte contains the data and is driven by the ADNS-3050 over MISO. The sensor outputs MISO bits on falling edges of SCLK and samples MOSI bits on every rising edge of SCLK.

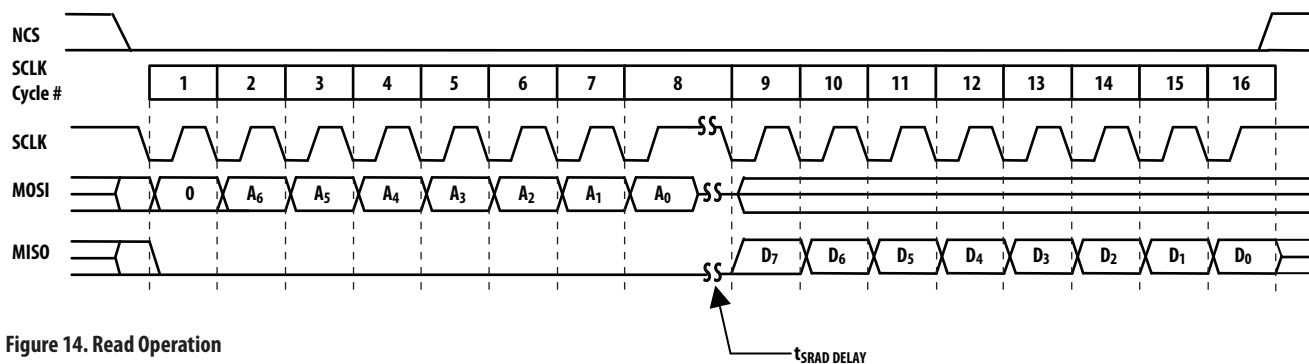

Figure 14. Read Operation

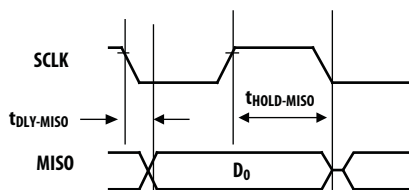

Figure 15. MISO delay

Note: The 500 ns minimum high state of SCLK is also the minimum MISO data hold time of the ADNS-3050. Since the falling edge of SCLK is actually the start of the next read or write command, the ADNS-3050 will hold the state of data on MISO until the falling edge of SCLK.

Required Timing between Read and Write Commands

There are minimum timing requirements between read and write commands on the serial port.

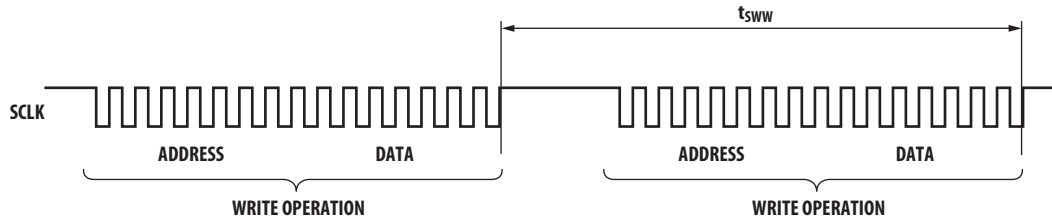

Figure 16. Timing between Two Write Commands

Timing between Two Write Commands

If the rising edge of the SCLK for the last data bit of the second write command occurs before the required delay (t_{SWW}), then the first write command may not complete correctly.

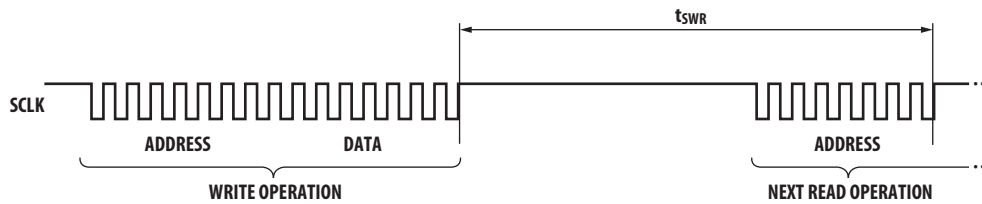

Figure 17. Timing between Write and Read Commands

Timing between Write and Read Commands

If the rising edge of SCLK for the last address bit of the read command occurs before the required delay (t_{SWR}), the write command may not complete correctly.

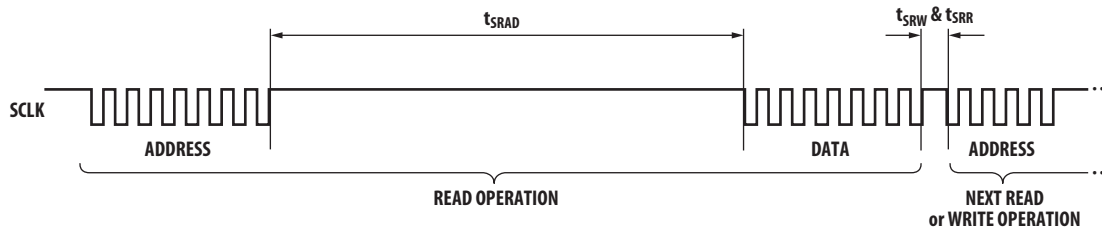

Figure 18. Timing between Read and Subsequent Write or Read Commands

Timing between Read and Subsequent Write or Read Commands

During a read operation SCLK should be delayed at least t_{SRAD} after the last address data bit to ensure that the ADNS-3050 has time to prepare the requested data. The falling edge of SCLK for the first address bit of either the read or write command must be at least t_{SRW} or t_{SRR} after the last SCLK rising edge of the last data bit of the previous read operation.

Mode	Motion Detection Routine	
	Motion Polling	MOTION Interrupt
Wired	Yes	Yes
Wireless	Not Supported	Yes

Motion Polling

The micro-controller will poll the sensor for valid motion data by checking on the MOTION_ST bit of MOTION_ST register in a periodic cycle. If MOTION_ST bit is set, motion data in DELTA_X and DELTA_Y registers are valid and ready to be read out by the micro-controller.

Motion polling sequence:

1. Read MOTION_ST bit of MOTION_ST register. If MOTION_ST bit = 1, go to step 2.
2. Read DELTA_X and DELTA_Y registers consecutively
3. Optional: Read PROD_ID register to check for communication link or sensor functionality. This Product ID verification MUST be done only after reading MOTION_ST, DELTA_X and DELTA_Y registers.

Motion polling is recommended to be used in the corded application like USB gaming mouse that requires fast motion response. This feature is not supported in wireless mode.

MOTION Interrupt

MOTION output signal (pin 3) can be used as interrupt input to the micro-controller of the mouse triggering the read command of motion data from the sensor whenever there is motion detected by the sensor. The MOTION signal is active low level-triggered output. The MOTION pin level will be driven low as long the MOTION_ST bit in register 0x02 is set and motion data in DELTA_X and DELTA_Y registers ready to be read out by the micro-controller. Once all the motion data has been read, DELTA_X and DELTA_Y values become zero, MOTION bit is reset and the MOTION pin level is driven high again.

MOTION Interrupt sequence:

1. When MOTION pin = Low, Read DELTA_X and DELTA_Y registers consecutively.
2. Optional: Read PROD_ID register to check for communication link or sensor functionality. This Product ID verification MUST be done only after reading MOTION_ST, DELTA_X and DELTA_Y registers.

MOTION interrupt should be implemented in wireless application to lengthen battery life. It is very useful as the main control of power management to wake up micro-controller and radio in the wireless system from rest modes.

Power Up Reset

Although ADNS-3050 does have an internal power up self reset circuitry, it is still highly recommended to follow the power up sequence below every time power is applied.

- i. Apply power
- ii. Drive NCS high, then low to reset the SPI port
- iii. Write 0x5a to register 0x3a
- iv. Wait for at least tSWW (or tWAKEUP when performing reset to wake up from Power Down)
- v. Write 0x20 to register 0x0d
- vi. Write 0x00 to register 0x41
- vii. Configure the desired sensor settings accordingly

Reset

ADNS-3050 can be reset by following power up reset sequence. A full reset will thus be executed and any register settings must be reloaded. The table below shows the state of the various pins during reset.

State of Signal Pins after VDD is Valid

Pin	During Reset	After Reset
NCS	Ignored	Functional
MISO	Low	Depends on NCS
SCLK	Ignored	Depends on NCS
MOSI	Ignored	Depends on NCS
LED	High	Functional

Power Down

The ADNS-3050 can be set to power down mode by writing 0xE7 to register 0x3B to disable the sensor. The SPI port should not be accessed during power down. Other ICs on the same SPI bus can be accessed, as long as the sensor's NCS pin is not asserted. The table below shows the state of various pins during power down. To exit Power Down, reset the sensor in order to wake it up. A full reset will thus be executed. Wait tWAKEUP before accessing the SPI port. Any register settings must then be reloaded.

Pin	During Power Down
MOTION	Undefined
NCS	Functional*
MOSI	Functional*
SCLK	Functional*
MISO	Undefined*

*Notes:

- NCS pin must be held to 1(HIGH) if SPI Bus is shared with other devices, it can be in either state if the sensor is the only device to connect to the host micro controller
- Reading on register should only be performed after existing from the power down mode. Any read operation during power down will not reflect the actual data of the register.

Low Power Management for Wireless Mode

The ADNS-3050 has three power-saving modes: Rest 1, Rest 2 and Rest 3 when wireless mode is enabled. Each mode can be configured to a different motion detection period, affecting response time to mouse motion (Response Time). The sensor automatically changes to the appropriate mode, depending on the time since the last reported motion (Downshift Time). The Response Time and Downshift Time for each mode are configurable via register addresses, 0x0e to 0x13.

To enable wireless mode for low power management with optimized tracking performance, implement the following steps after sensor power up reset sequence.

- i. Enable power-saving modes by setting F_AWAKE bit = 0 in NAV_CTRL2 register.
- ii. Write 0x26 to register 0x35
- iii. Write 0x30 to register 0x14
- iv. Write 0x30 to register 0x18
- v. Write 0x01 to register 0x43
- vi. Write 0x01 to register 0x40

Lift Detection Cutoff Algorithm

When the mouse is raised from the tracking surface which is also known as lifted condition, there is a specific z-height whereby the tracking of the sensor will cease. However the tracking cutoff height of the ADNS-3050 sensor varies with the different tracking surfaces. In general to have a lower tracking cutoff height than the default settings, the algorithm illustrated in the form of a pseudo code is recommended as Z-height monitoring routine in the micro-controller firmware.

Example of pseudo code in C language:

```

If (MOTION)
{
    //Read sensor motion data and pixel statistic
    EA = 0;
    SHUTTER_HI = spi_read_sensor(ADNS3050_SHUT_HI_ADDR);
    SHUTTER_LO = spi_read_sensor(ADNS3050_SHUT_LO_ADDR);
    SQUAL = spi_read_sensor(ADNS3050_SQUAL_ADDR);
    PIXEL_ACCUM = spi_read_sensor(ADNS3050_PIX_ACCUM_ADDR);
    EA = 1;
    SHUTTER = (double)SHUTTER_HI*256+(double)SHUTTER_LO;
    AVERAGE_SHUTTER = 1024*(double)PIXEL_ACCUM/SHUTTER;
    // Lift detection monitoring
    if(AVERAGE_SHUTTER<440 && SQUAL<55)
    {
        SYS_deltaX = 0; //Motion data suppression
        SYS_deltaY = 0; //Motion data suppression
    }
}

```

Registers

The ADNS-3050 registers are accessible via the serial port. The registers are used to read motion data and status as well as to set the device configuration.

Address	Register Name	Register Description	Read/Write	Default Value
0x00	PROD_ID	Product ID	R	0x09
0x01	REV_ID	Revision ID	R	0x00
0x02	MOTION_ST	Motion Status	R/W	0x00
0x03	DELTA_X	Delta_X	R	0x00
0x04	DELTA_Y	Delta_Y	R	0x00
0x05	SQUAL	Squal Quality	R	0x00
0x06	SHUT_HI	Shutter Open Time (Upper 8-bit)	R	0x01
0x07	SHUT_LO	Shutter Open Time (Lower 8-bit)	R	0x00
0x08	PIX_MAX	Maximum Pixel Value	R	0x00
0x09	PIX_ACCUM	Average Pixel Value	R/W	0x00
0x0a	PIX_MIN	Minimum Pixel Value	R	0x00
0x0b	PIX_GRAB	Pixel Grabber	R/W	0x00
0x0d	MOUSE_CTRL	Mouse Control	R/W	0x01
0x0e	RUN_DOWNSHIFT	Downshift Time from Run to Rest 1	R/W	0x46
0x0f	REST1_PERIOD	Time Period of Rest 1	R/W	0x00
0x10	REST1_DOWNSHIFT	Downshift Time from Rest 1 to Rest 2	R/W	0x4f
0x11	REST2_PERIOD	Time Period of Rest 2	R/W	0x09
0x12	REST2_DOWNSHIFT	Downshift Time from Rest 2 to Rest 3	R/W	0x2f
0x13	REST3_PERIOD	Time Period of Rest 3	R/W	0x31
0x1c	SHUT_THR	Shutter Threshold	R/W	0x41
0x1d	SQUAL_THRESHOLD	Squal Threshold	R/W	0x3d
0x22	NAV_CTRL2	LED Mode Configuration	R/W	0x00
0x25	MISC_SETTINGS	DCR and wakeup settings Register	R/W	0x61
0x33	RESOLUTION	Full Resolution Register	R/W	0x04
0x34	LED_PRECHARGE	LED precharge time Register	R/W	0xa0
0x3a	RESET	Reset	W	0x00
0x3b	SHUTDOWN	Shutdown Register	W	0x00
0x3f	NOT_REV_ID	Inverted Revision ID	R	0xff
0x45	REST_MODE_CONFIG	Rest Mode Configuration	R/W	0x00

PROD_ID Address: 0x00
 Access: Read Reset Value: 0x09

Bit	7	6	5	4	3	2	1	0
Field	PID7	PID6	PID5	PID4	PID3	PID2	PID1	PID0

Data Type: 8-Bit unsigned integer

USAGE: This register contains a unique identification assigned to the ADNS-3050. The value in this register does not change; it can be used to verify that the serial communications link is functional. If using this register to verify serial communications link during rest modes, please read following registers in this sequence: 0x00, 0x02, 0x03, 0x04, 0x00 (regardless of register 0x02's status). If both or either one of the read 0x00 value is correct, no additional action is required as the serial communication link is good. Only if both read 0x00 value attempts are wrong, perform a reset operation to the sensor to restore the serial communications link.

Note: Highly recommended to use Motion pin function during rest modes for motion detection in wireless mode.

REV_ID Address: 0x01
 Access: Read Reset Value: 0x00

Bit	7	6	5	4	3	2	1	0
Field	RID7	RID6	RID5	RID4	RID3	RID2	RID1	RID0

Data Type: 8-Bit unsigned integer

USAGE: This register contains the IC revision. It is subject to change when new IC versions are released.

MOTION_ST Address: 0x02
 Access: Read/Write Reset Value: 0x00

Bit	7	6	5	4	3	2	1	0
Field	MOTION_ST	RSVD	RSVD	RSVD	RSVD	RSVD	RSVD	RSVD

Data Type: Bit field.

USAGE: Register 0x02 allows the user to determine if motion has occurred since the last time it was read. If the MOTION_ST bit is set, then the user should read registers 0x03 (DELTA_X) and 0x04 (DELTA_Y) to get the accumulated motion data. Read this register before reading the DELTA_X and DELTA_Y registers. Writing any data into this register clears MOTION_ST bit, DELTA_X and DELTA_Y registers. However the written data byte will not be saved.

Bit	Field Name	Description
7	MOTION_ST	Motion detected since last report 0 = No motion (default) 1 = Motion occurred, data in DELTA_X and DELTA_Y registers ready to be read
6-0	RSVD	Reserved

) Vo - 8 \ V o

DELTA_X Address: 0x03

Access: Read Reset Value: 0x00

Bit	7	6	5	4	3	2	1	0
Field	X7	X6	X5	X4	X3	X2	X1	X0

Data Type: Eight bit 2's complement number.

USAGE: X-axis movement in counts since last report. Absolute value is determined by resolution. Reading this register clears the content of this register.

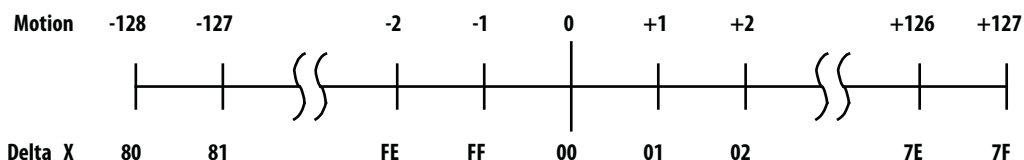

NOTE: Pixart Recommend that register 0x03 and 0x04 to be read consecutively

DELTA_Y Address: 0x04

Access: Read Reset Value: 0x00

Bit	7	6	5	4	3	2	1	0
Field	Y7	Y6	Y5	Y4	Y3	Y2	Y1	Y0

Data Type: Eight bit 2's complement number.

USAGE: Y-axis movement in counts since last report. Absolute value is determined by resolution. Reading this register clears the content of this register.

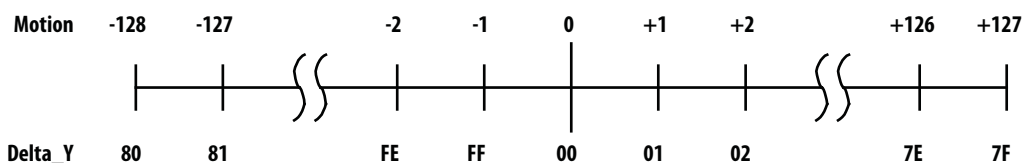

NOTE: Pixart Recommend that register 0x03 and 0x04 to be read consecutively

.....) Vo - 8 \ V o

SQUAL Address: 0x05
 Access: Read Reset Value: 0x00

Bit	7	6	5	4	3	2	1	0
Field	SQ7	SQ6	SQ5	SQ4	SQ3	SQ2	SQ1	SQ0

Data Type: Upper 8 bits of a 9-bit unsigned integer.

USAGE: SQUAL (Surface Quality) is a measure of the number of valid features visible by the sensor in the current frame. The maximum SQUAL register value is 128. Since small changes in the current frame can result in changes in SQUAL, variations in SQUAL when looking at a surface are expected. The graph below shows 800 sequentially acquired SQUAL values, while a sensor was moved slowly over white paper. SQUAL is nearly equal to zero, if there is no surface below the sensor. SQUAL is typically maximized when the navigation surface is at the optimum distance from the imaging lens (the nominal Z-height).

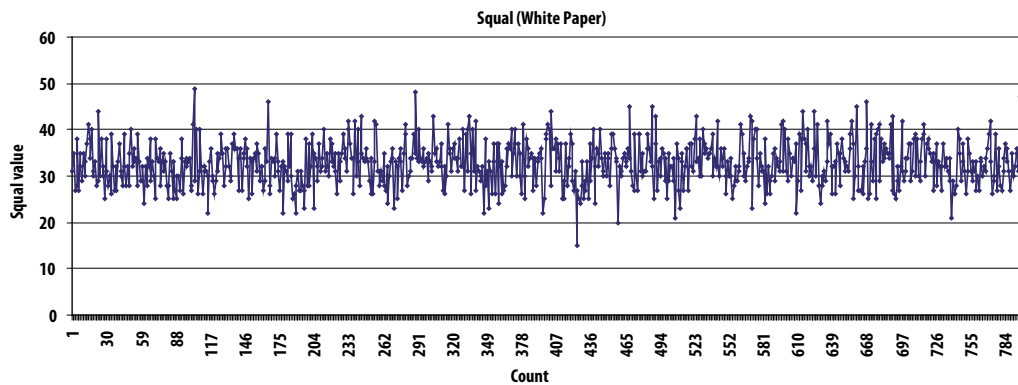

Figure 20. Squal values (white paper)

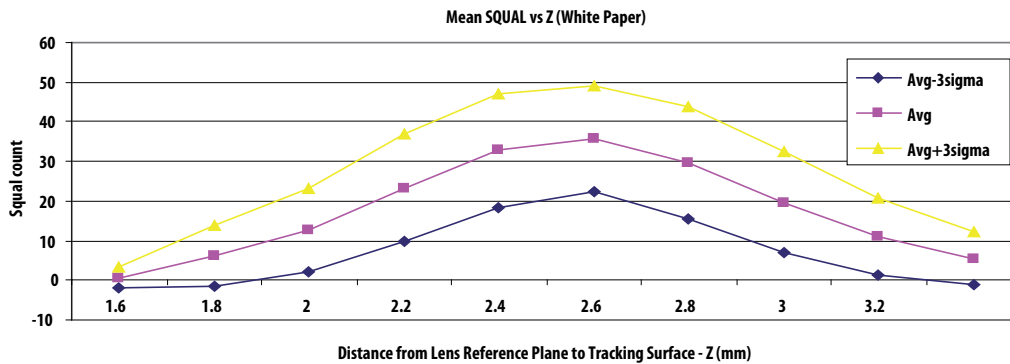

Figure 21. Mean squal vs. Z (White Paper)

.....) Vo - 8 \ V o

SHUT_HI Address: 0x06
 Access: Read Reset Value: 0x01

Bit	7	6	5	4	3	2	1	0
Field	S15	S14	S13	S12	S11	S10	S9	S8

SHUT_LO Address: 0x07
 Access: Read Reset Value: 0x00

Bit	7	6	5	4	3	2	1	0
Field	S7	S6	S5	S4	S3	S2	S1	S0

Data Type: Sixteen bit unsigned integer.

USAGE: Units are in clock cycles. Read SHUT_HI first, then SHUT_LO. They should be read consecutively. The shutter is adjusted to keep the average and maximum pixel values within normal operating ranges. The shutter value is automatically adjusted.

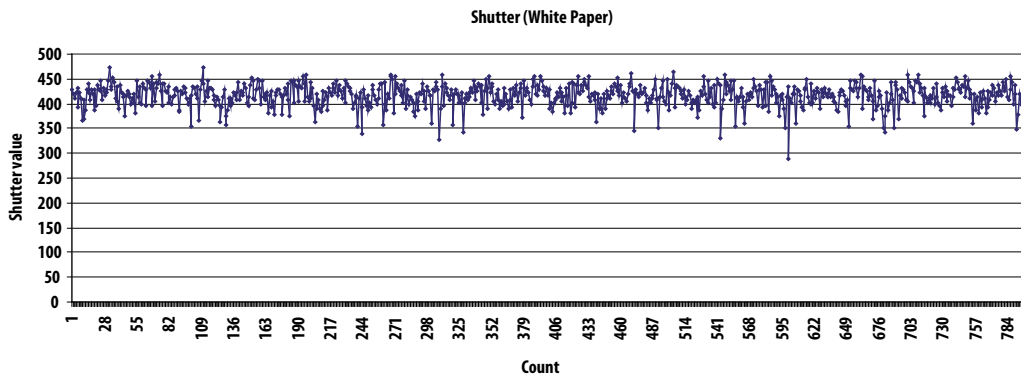

Figure 22. Shutter (white paper).

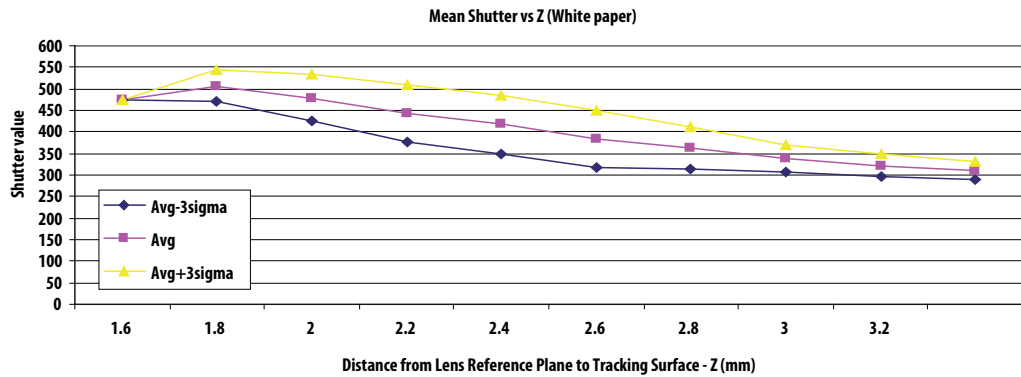

Figure 23. Mean shutter vs. Z (white paper).

PIX_MAX Address: 0x08
 Access: Read Reset Value: 0x00

Bit	7	6	5	4	3	2	1	0
Field	MP7	MP6	MP5	MP4	MP3	MP2	MP1	MP0

Data Type: Eight-bit number.

USAGE: Store the highest pixel value in current frame. Minimum value = 0, maximum value = 254.
 The highest pixel value may vary with different frame.

PIX_ACCUM Address: 0x09
 Access: Read/Write Reset Value: 0x00

Bit	7	6	5	4	3	2	1	0
Field	AP7	AP6	AP5	AP4	AP3	AP2	AP1	AP0

Data Type: High 8-bits of an unsigned 17-bit integer.

USAGE: This register stores the accumulated pixel value of the last image taken. This register can be used to find the average pixel value, where Average Pixel = (register value AP[7:0])* 1.058
 The maximum accumulated value is 122936 but only bits [16:9] are reported, therefore the maximum register value is 240. The minimum is 0. The PIX_ACCUM value may vary with different frame.

PIX_MIN Address: 0x0a
 Access: Read Reset Value: 0x00

Bit	7	6	5	4	3	2	1	0
Field	MP7	MP6	MP5	MP4	MP3	MP2	MP1	MP0

Data Type: Eight-bit number.

USAGE: Store the lowest pixel value in current frame. Minimum value = 0, maximum value = 254.
 The minimum pixel value may vary with different frame.

.....) Vo - 8 \ V o

PIX_GRAB Address: 0x0b
 Access: Read/Write Reset Value: 0x00

Bit	7	6	5	4	3	2	1	0
Field	PG_VALID	PG6	PG5	PG4	PG3	PG2	PG1	PG0

Data Type: Eight bit word.

USAGE: The pixel grabber captures 1 pixel per frame. Bit-7 (MSB) of this register will be set to indicate that the 7-bit pixel data (PG[6:0]) is valid for grabbing. In a 19x19 pixel array, it will take 361 read operations to grab all the pixels to form the complete image.

Bit(s)	Field Name	Description
7	PG_VALID	Pixel Grabber Valid
6:0	PG[6:0]	Pixel Data

NOTE: Any write operation into this register will reset the grabber to origin (pixel 0 position). The sensor should not be moved before the 361 read operations are completed to ensure original data is grabbed to produce good (uncorrupted) image.

19 x 19 Pixel Array Address Map – (Surface reference view from top of mouse)

342	323	304	285	266	247	228	209	190	171	152	133	114	95	76	57	38	19	0	First
343	324	305	286	267	248	229	210	191	172	153	134	115	96	77	58	39	20	1	
344	325	306	287	268	249	230	211	192	173	154	135	116	97	78	59	40	21	2	
345	326	307	288	269	250	231	212	193	174	155	136	117	98	79	60	41	22	3	
346	327	308	289	270	251	232	213	194	175	156	137	118	99	80	61	42	23	4	
347	328	309	290	271	252	233	214	195	176	157	138	119	100	81	62	43	24	5	
348	329	310	291	272	253	234	215	196	177	158	139	120	101	82	63	44	25	6	
349	330	311	292	273	254	235	216	197	178	159	140	121	102	83	64	45	26	7	
350	331	312	293	274	255	236	217	198	179	160	141	122	103	84	65	46	27	8	
351	332	313	294	275	256	237	218	199	180	161	142	123	104	85	66	47	28	9	
352	333	314	295	276	257	238	219	200	181	162	143	124	105	86	67	48	29	10	
353	334	315	296	277	258	239	220	201	182	163	144	125	106	87	68	49	30	11	
354	335	316	297	278	259	240	221	202	183	164	145	126	107	88	69	50	31	12	
355	336	317	298	279	260	241	222	203	184	165	146	127	108	89	70	51	32	13	
356	337	318	299	280	261	242	223	204	185	166	147	128	109	90	71	52	33	14	
357	338	319	300	281	262	243	224	205	186	167	148	129	110	91	72	53	34	15	
358	339	320	301	282	263	244	225	206	187	168	149	130	111	92	73	54	35	16	
359	340	321	302	283	264	245	226	207	188	169	150	131	112	93	74	55	36	17	
360	341	322	303	284	265	246	227	208	189	170	151	132	113	94	75	56	37	18	Last

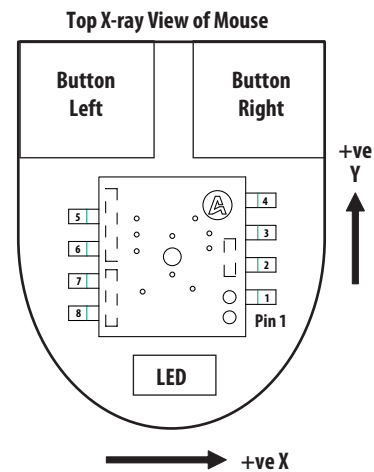

) Vo - 8 \ V o

MOUSE_CTRL Address: 0x0d
 Access: Read/Write Reset Value: 0x01

Bit	7	6	5	4	3	2	1	0
Field	RSVD	RSVD	1	RES2	RES1	RES0	PD	0

Data Type: Bit field.

USAGE: Resolution and chip reset information can be accessed or to be edited by this register.

Bit	Field Name	Description
5	1	Must set to 1
4:2	RES [2:0]	Set the resolution of sensor 000: 1000 dpi (default) 001: 250 dpi 010: 500 dpi 011: 1250 dpi 100: 1500 dpi 101: 1750 dpi 110: 2000 dpi
Reserved	Reserved	Reserved
0	0	Must set to 0

Note: As the sensor resolution increases, slight performance degradation on certain surfaces may be observed. For higher than 500 dpi setting, use 12-bit motion reporting to achieve the maximum speed.

RUN_DOWNSHIFT Address: 0x0e
 Access: Read/Write Reset Value: 0x46

Bit	7	6	5	4	3	2	1	0
Field	RUD7	RUD6	RUD5	RUD4	RUD3	RUD2	RUD1	RUD0

Data Type: Eight bit number.

USAGE: This register sets the Run to Rest1 mode downshift time. The configurable value is range from 0x46 to 0xff. Min value for this register must be 0x46 or 70 in decimal. Units are 16 frames (about 430ms@2600fps)

REST1_PERIOD Address: 0x0f

Access: Read/Write Reset Value: 0x00

Bit	7	6	5	4	3	2	1	0
Field	RIP7	RIP6	RIP5	RIP4	RIP3	RIP2	RIP1	RIP0

Data Type: Eight bit number.

USAGE: This register sets the Rest1 time period in seconds. Min value for this register is 0. Max value is 0xFD.
 Rest 1 Period = (Register value (decimal) +1) x 0.007

NOTE: Writing into this register when the sensor itself is operating in this rest mode may result in unexpected behavior of the sensor. To avoid this from happening, below commands should be incorporated prior and after the write command into this register.

- i. Write 0x80 to register 0x22H prior to writing into this register
- ii. Writing the desired value to this REST1_PERIOD register
- iii. Write 0x00 to register 0x22H after to writing into this register

REST1_DOWNSHIFT Address: 0x10

Access: Read/Write Reset Value: 0x4f

Bit	7	6	5	4	3	2	1	0
Field	R1D7	R1D6	R1D5	R1D4	R1D3	R1D2	R1D1	R1D0

Data Type: Eight bit number.

USAGE: This register sets the Rest1 to Rest2 mode downshift time.
 Rest 1 Downshift Time = (Register value (decimal) x (Rest1 period) x 16. Min value for this register is 0.

REST2_PERIOD Address: 0x11

Access: Read/Write Reset Value: 0x09

Bit	7	6	5	4	3	2	1	0
Field	R2P7	R2P6	R2P5	R2P4	R2P3	R2P2	R2P1	R2P0

Data Type: Eight bit number.

USAGE: This register sets the Rest2 period in seconds. Min value for this register is 0. Max value is 0xFD.
 Rest 2 Period = (Register value (decimal) +1) x 0.007

NOTE: Writing into this register when the sensor itself is operating in this rest mode may result in unexpected behavior of the sensor. To avoid this from happening, below commands should be incorporated prior and after the write command into this register.

- i. Write 0x80 to register 0x22H prior to writing into this register
- ii. Writing the desired value to this REST2_PERIOD register
- iii. Write 0x00 to register 0x22H after to writing into this register

REST2_DOWNSHIFT Address: 0x12

Access: Read/Write Reset Value: 0x2f

Bit	7	6	5	4	3	2	1	0
Field	R2D7	R2D6	R2D5	R2D4	R2D3	R2D2	R2D1	R2D0

Data Type: Eight bit number

USAGE: This register sets the Rest1 to Rest2 mode downshift time. Min value for this register is 0.

$$\text{Rest 2 Downshift Time} = (\text{Register value (decimal)} \times (\text{Rest2 period}) \times 128$$

REST3_PERIOD Address: 0x13

Access: Read/Write Reset Value: 0x31

Bit	7	6	5	4	3	2	1	0
Field	R3P7	R3P6	R3P5	R3P4	R3P3	R3P2	R3P1	R3P0

Data Type: Eight bit number.

USAGE: This register sets the Rest3 period in seconds. Min value for this register is 0. Max value is 0xFD.

$$\text{Rest 3 Period} = (\text{Register Value (decimal)} + 1) \times 0.007$$

NOTE: Writing into this register when the sensor itself is operating in this rest mode may result in unexpected behavior of the sensor. To avoid this from happening, below commands should be incorporated prior and after the write command into this register.

- i. Write 0x80 to register 0x22H prior to writing into this register
- ii. Writing the desired value to this REST3_PERIOD register
- iii. Write 0x00 to register 0x22H after to writing into this register

PREFLASH_RUN Address: 0x14

Access: Read/Write Reset Value: 0x80

Bit	7	6	5	4	3	2	1	0
Field	PREFLASH_CTRL	PREFLASH_T	PREFLASH_T	PREFLASH_T	PREFLASH_T	PREFLASH_T	PREFLASH_T	PREFLASH_T

Data Type: Bit field

USAGE: This register usage is to turn on LED to saturate sensor array before electronic shutter is open.

Bit	Field Name	Description
7	PREFLASH_CTRL	0: Preflash control during idle state. 1: Preflash control during processing state.
6:0	PREFLASH_T	PREFLASH_T PREFLASH_CTRL=1: Preflash time = Processing time - PREFLASH_T*32*clk_period + Idle time PREFLASH_CTRL=0: Preflash time = PREFLASH_T*64*clk_period

PREFLASH_RUN_DARK Address: 0x18

Access: Read/Write Reset Value: 0x80

Bit	7	6	5	4	3	2	1	0
Field	PREFLASH_CTRL_D	PREFLASH_T_D	PREFLASH_T_D	PREFLASH_T_D	PREFLASH_T_D	PREFLASH_T_D	PREFLASH_T_D	PREFLASH_T_D

Data Type: Bit field

USAGE: This register usage is to turn on LED to saturate sensor array before electronic shutter is open on dark surface.

Bit	Field Name	Description
7	PREFLASH_CTRL_D	0: Preflash control during idle state. 1: Preflash control during processing state.
6:0	PREFLASH_T_D	PREFLASH_T_D PREFLASH_CTRL=1: Preflash time = Processing time - PREFLASH_T_D*32*clk_period + Idle time PREFLASH_CTRL=0: Preflash time = PREFLASH_T_D*64*clk_period [if PREFLASH_T_D > Processing time/32 (~110 counts), Preflash time = Idle time]

MOTION_EXT Address: 0x1b

Access: Read Reset Value: 0x00

Bit	7	6	5	4	3	2	1	0
Field	MOT_EXT	PG_VALID	PG_FIRST	DEL_Y_OVERFLOW	DEL_X_OVERFLOW	RSVD	RSVD	RSVD

Data Type: Bit field

USAGE: This register is store the status of current motion that occurred.

Bit	Field Name	Description
7	MOTION_EXT	0: No Motion default 1: Motion occurred
6	PG_VALID	1: Pixel Grabber Valid
5	PG_FIRST	1: Pixel Grabber First
4	Delta Y overflow	0: No Overflow 1: Delta Y overflow
3	Delta X overflow	0: No Overflow 1: Delta Y overflow
2:0	Reserved	Reserved

SHUT_THR Address: 0x1c
 Access: Read/Write Reset Value: 0x41

Bit	7	6	5	4	3	2	1	0
Field	SHT_THR	SHT_THR	SHT_THR	SHT_THR	SHT_THR	SHT_THR	SHT_THR	SHT_THR

Data Type: Bit field

USAGE: This register is used to configure the rest mode run downshift frame operation of the sensor with the shutter time.

Bit	Field Name	Description
7:0	SHUT_THRESH	Shutter Threshold

SQUAL_THRESHOLD Address: 0x1d
 Access: Read/Write Reset Value: 0x3d

Bit	7	6	5	4	3	2	1	0
Field	ST	ST	ST	ST	ST	PT	PT	PT

Data Type: Bit field

USAGE: This register is used to configure the surface quality limit of the sensor.

Bit	Field Name	Description
7:3	ST	Minimum number of features to navigate
2:0	PT	Minimum size of feature to be usable.

NAV_CTRL2 Address: 0x22
 Access: Read/Write Reset Value: 0x00

Bit	7	6	5	4	3	2	1	0
Field	F_AWAKE	0	0	RSVD	RSVD	RSVD	RSVD	RSVD

Data Type: Bit field

USAGE: This register is used to configure the rest mode operation of the sensor.

Bit	Field Name	Description
7	F_AWAKE	Enable/Disable rest mode 0: Enabled rest mode 1: Disabled rest mode. (Default)
6:5	0	Must be set to 0

MISC_SETTINGS Address: 0x25

Access: Read/Write Reset Value: 0x61

Bit	7	6	5	4	3	2	1	0
Field	MSR	RSVD	RSVD	RSVD	MSR	DS	DS	DS

Data Type: Bit field

USAGE: This register is used to configure the DCR and wakeup settings register.

Bit	Field Name	Description
7	Reserved	Reserved
6:4	MSR	Minimum number of feature to wakeup from rest unit in multiple of min_sq_run
3	Reserved	Reserved
2:0	DS	Number of bits to shift off dcr (decorrelation if correlation threshold < auto correlation)

RESOLUTION Address: 0x33

Access: Read/Write Reset Value: 0x04

Bit	7	6	5	4	3	2	1	0
Field	RSVD	RSVD	RSVD	RES_EN	DPI	DPI	DPI	DPI

Data Type: Bit field

USAGE: This register is used to configure the resolution of the sensor.

Bit	Field Name	Description
7:5	Reserved	Reserved
4	RES_EN	0: Disable resolution setting 1: Enable resolution setting
3:0	DPI	0x00: 400dpi 0x01: 250dpi 0x02: 500dpi 0x03: 750dpi 0x04: 1000dpi 0x05: 1250dpi 0x06: 1500dpi 0x07: 1750dpi 0x08: 2000dpi

LED_PRECHARGE Address: 0x34

Access: Read/Write Reset Value: 0xa0

Bit	7	6	5	4	3	2	1	0
Field	LED_PRE	LED_PRE	LED_PRE	LED_PRE	LED_PRE	LED_PRE	LED_PRE	LED_PRE

Data Type: Bit field

USAGE: This register is used to configure the LED precharge of the sensor. The default pre flash is about 190uS for nominal clock of 26MHz~28Mhz.

Bit	Field Name	Description
7:0	LED_PRECHARGE	precharge time (in clock counts) = LED_PRECHARGE" *32 + 30

FRAME_IDLE Address: 0x35

Access: Read/Write Reset Value: 0x00

Bit	7	6	5	4	3	2	1	0
Field	FRAME_IDLE	FRAME_IDLE	FRAME_IDLE	FRAME_IDLE	FRAME_IDLE	FRAME_IDLE	FRAME_IDLE	FRAME_IDLE

Data Type: Eight Bit Unsigned Integer

USAGE: This register is used to control the frame rate. The value in this register is used to add frame idling time, which effectively reduces the frame rate.

$$\text{frame_idle_time (in clock counts)} = (\text{register value}) * 32$$

$$\text{Frame period (in clock counts)} = \text{shutter_time (reg 0x06 and reg 0x07)} + (3400 \text{ clocks}) + \text{frame_idle_time}$$

When this register is set to 0x00, the maximum frame rate is about 6666 fps @26MHz internal clock frequency

Bit	Field Name	Description
7:0	FRAME_IDLE	Frame Idling time(in clock counts)=FRAME_IDLE*32

POWER_UP_RESET Address: 0x3a

Access: Write Reset Value: 0x00

Bit	7	6	5	4	3	2	1	0
Field	RESET	RESET	RESET	RESET	RESET	RESET	RESET	RESET

Data Type: Bit field

USAGE: This register is used to configure the resolution of the sensor.

Bit	Field Name	Description
7:0	POWER_UP_RESET	Power up reset. 0x5a/0x5b for full reset. 0x96/0x97 for partial reset.

SHUTDOWN Address: 0x3b

Access: Write Reset Value: 0x00

Bit	7	6	5	4	3	2	1	0
Field	SD	SD	SD	SD	SD	SD	SD	SD

Data Type: Bit field

USAGE: This register is used to shut down the sensor

Bit	Field Name	Description
7:0	SHUTDOWN	Chip Shutdown Write 0xe7 to power down sensor. Write 0x5a to register 0x3a to reset the sensor in order to wake-up

INV_REV_ID Address: 0x3f
 Access: Read Reset Value: 0xff

Bit	7	6	5	4	3	2	1	0
Field	RRID7	RRID6	RRID5	RRID4	RRID3	RRID2	RRID1	RRID0

Data Type: Eight bit unsigned integer

USAGE: This register contains the inverse of the revision ID which is located at register 0x01.

LED_CTRL Address: 0x40
 Access: Read/Write Reset Value: 0x00

Bit	7	6	5	4	3	2	1	0
Field	RSVD	RSVD	RSVD	RSVD	LED_CONT_OFF	LED_CONT_OFF	LED_SEL	LED_SEL

Data Type: Eight bit unsigned integer.

USAGE: This register is used to control the LED operating mode and current to optimization the power consumption.

Bit	Field Name	Description
7:4	Reserved	Reserved
3	LED_CONT_OFF	0: Normal operation (Default) 1: LED continuous off
2	LED_CONT_ON	0: Normal operation (Default) 1: LED continuous on
1:0	LED_SEL	0x00: LED current set to 20mA 0x01: LED current set to 15mA 0x02: LED current set to 36mA 0x03: LED current set to 30mA

Note: if LED operating in Automatic current switching mode (AUTO_LED_CONTROL [0] at address 0x43 is cleared, LED current setting (LED_CONTROL) [1:0]) will be ignored. Only when AUTO current switching is disabled through setting AUTO_LED_CONTROL [0], the LED driver current is determine by LED_CONTROL [1:0].

MOTION_CTRL Address: 0x41
 Access: Read/Write Reset Value: 0x40

Bit	7	6	5	4	3	2	1	0
Field	MOT_ACT_HI	MOT_SENS	RSVD	RSVD	RSVD	RSVD	RSVD	RSVD

Data Type: Eight bit unsigned integer.

USAGE: This register is used to configure sensor motion control.

Bit	Field Name	Description
7	MOTION_ACTIVE_HI	0: Motion active low (default) 1: Motion active high
6	MOTION_SENSITIVITY	0: Motion pin is level sensitive 1: Motion pin is edge sensitive(default)
5:0	Reserved	Reserved

AUTO_LED_CONTROL Address: 0x43
 Access: Read/Write Reset Value: 0x08

Bit	7	6	5	4	3	2	1	0
Field	RSVD	RSVD	RSVD	RSVD	LED_HI	LED_HI	AUTO_LED_DS	AUTO_LED_DS

Data Type: Bit field

USAGE: This is a “smart” LED drive feature whereby the LED current is self adjusting between the low and high current settings (bit 3:1) according to the brightness of the tracking surface if this feature is enable (via clearing bit 0). The brighter the surface, the lower the LED current will be. If A_LED_DIS (bit 0) is set, this means AUTO_LED mode is disable, then the LED current determine by LSEL[1:0] setting in LED_CTRL register (0x40).

Bit	Field Name	Description
7:4	Reserved	Reserved
3:2	LED_HI	0x0: Auto LED high current is 15mA 0x1: Auto LED high current is 20mA 0x2: Auto LED high current is 30mA 0x3: Auto LED high current is 36mA
1	LED_LO	0x0: Auto LED low current is 15mA 0x1: Auto LED low current is 20mA
0	AUTO_LED_DIS	0x0: Enable Auto LED current switching 0x1: Disable Auto LED current switching

NOTE: When AUTO LED is enable, the AUTO_LED current will be switched between low and high current setting determined by LED_LO and LED_HI [1:0]. If LED_LO current setting is higher than the LED_HI, the current will be based on the higher setting. For example if the LED_LO is 20mA and LED_HI is 15mA, the AUTOLED current will be fixed at 20mA.

REST_MODE_CONFIG Address: 0x45
 Access: Read/Write Reset Value: 0x00

Bit	7	6	5	4	3	2	1	0
Field	RM1	RM0	RSVD	RSVD	RSVD	RSVD	RSVD	RSVD

Data Type: Eight bit unsigned integer.

USAGE: This register is used to set the operating mode of the ADNS-3050.

Bit(s)	Field Name	Description
7:6	RM[1:0]	Sensor Operating Mode 0x00: Normal (default) 0x01: Rest 1 0x02: Rest 2 0x03: Rest 3
5:0	RSVD	Reserved

Read operation to REST_MODE_CONFIG indicates which mode the sensor is in. Write operation into this register will force the sensor into rest modes (Rest 1, 2 or 3). Write the value 0x40 into 0x45 register to force sensor into Rest 1, 0x80 to Rest 2 or 0xC0 to Rest 3. To get out of any forced rest mode, write 0x00 into this register to set back to normal mode.