

ADNS-5700-XXXX

Optical Mouse Sensor



Data Sheet



Lead (Pb) Free
RoHS 6 fully
compliant



Description

The ADNS-5700-XXXX is a compact, one chip USB optical mouse sensor for implementing a non-mechanical tracking engine for computer mice.

It is based on optical navigation technology that measures changes in position by optically acquiring sequential surface images (frames) and mathematically determining the direction and magnitude of movement.

The sensor is in a 18 -pin optical package that is designed to be used with the ADNS-5100 round lens , ADNS-5100-001 trim lens or ADNS-5100-002 truncated round lens, the ADNS-5200 Clip and the HLMP-ED80 LED-XX000. These parts provide a complete and compact mouse sensor. There are no moving parts, and precision optical alignment is not required, facilitating high volume assembly.

The output format is USB. This device meets HID Revision 1.11 specification and is compatible with USB Revision 2.0 specification.

Frame rate is varied internally to the sensor to achieve tracking and speed performance, eliminating the need for the use of many registers.

Default resolution is specified as 1000 counts per inch, with rates of motion up to 30 inches per second. Buttons and tilt wheel features are also available.

A complete mouse can be built with the addition of a PC board, switches and mechanical Z-wheel, plastic case and cable.

Theory of Operation

The ADNS-5700-XXXX is based on Optical Navigation Technology. It contains an Image Acquisition System (IAS), a Digital Signal Processor (DSP) and USB stream output.

The IAS acquires microscopic surface images via the lens and illumination system provided by the ADNS-5100 round lens , ADNS-5100-001 trim lens or ADNS-5100-002 truncated round lens, ADNS-5200 clip and HLMP-ED80-XX000. These images are processed by the DSP to determine the direction and distance of motion. The DSP generates the x and y relative displacement values which are converted to USB motion data.

Features

- Optical navigation technology
- Default resolution 1000cpi, selectable resolution 800cpi or 1200cpi through different part number
- High speed motion detection up to 30 inches per second (ips) and acceleration of 8g
- Accurate navigation over a wide variety of surfaces
- No precision optical alignment needed
- Wave Solderable
- Single 5.0 volt power supply
- Meets USB Revision 2.0 specification
- Meets HID Revision 1.11
- Tilt Wheel function
- Optical or Mechanical Z-Wheel function
- 12bits motion reporting
- 2 axis sensor rotation : 0° or 270°

Applications

- Mice for desktop PC's, Workstations, and portable PC's
- Trackballs
- Integrated input devices

Pinout 18pin PDIP

ADNS-5700-XXXX

Pin Number	3 button				5 button	
	H3PB, H3QB	H4PB, H4QB	H3MB, H3NB	H4MB, H4NB	H5PD, H5QD	H5MD, H5ND
1	D +	D +	D +	D +	D +	D +
2	D -	D -	D -	D -	D -	D -
3	ZA	ZA	ZA	ZA	ZA	ZA
4	ZB	ZB	ZB	ZB	ZB	ZB
5	LED_GND	LED_GND	LED_GND	LED_GND	LED_GND	LED_GND
6	XY_LED	XY_LED	XY_LED	XY_LED	XY_LED	XY_LED
7	V _{DD5}	V _{DD5}	V _{DD5}	V _{DD5}	V _{DD5}	V _{DD5}
8	GND	GND	GND	GND	GND	GND
9	ZLED	ZLED	REG0	REG0	ZLED	REG0
10	REG0 / V _{DD3}	REG0 / V _{DD3}	V _{DD3}	V _{DD3}	REG0 / V _{DD3}	V _{DD3}
11	NC	TL	NC	TL	B4	B4
12	NC	TR	NC	TR	OSC_IN	OSC_IN
13	GND	GND	GND	GND	GND	GND
14	OSC_IN	OSC_IN	OSC_IN	OSC_IN	OSC_OUT	OSC_OUT
15	OSC_OUT	OSC_OUT	OSC_OUT	OSC_OUT	B3	B3
16	B3	B3	B3	B3	B2	B2
17	B2	B2	B2	B2	B1	B1
18	B1	B1	B1	B1	B5	B5

Pin description table

Pin Name	Description
D +	USB D+ line
D -	USB D- line
ZA	ZA Optical wheel quadrature input
ZB	ZB Optical wheel quadrature input
LED_GND	LED ground
XY_LED	XY_LED Input
V _{DD5}	5 Volt Power (USB VBUS)
GND	System ground
ZLED	Z-Wheel LED input
REG0 / V _{DD3}	3 Volt Power V _{DD3}
NC	No Connect
OSC_IN	Ceramic resonator input
OSC_OUT	Ceramic resonator output
B5	Fifth Button
B4	Fourth Button
B3	Middle button input
B2	Right button input
B1	Left button input

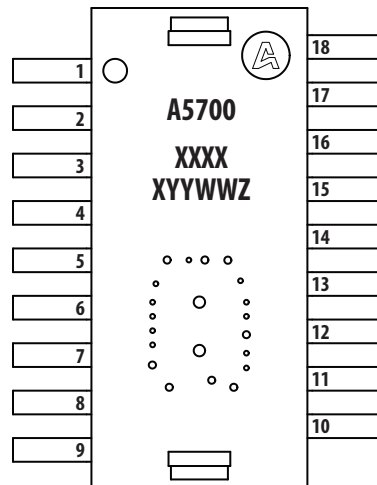

Figure 1a. Package pinout

Note : See table for Part number marking

DISCLAIMER: ALL DESIGNERS AND MANUFACTURERS OF THIS DESIGN MUST ASSURE THAT THEY HAVE ALL NECESSARY INTELLECTUAL PROPERTY RIGHTS.

Strap (Jumper) Table

The PID/string strap matrix is the following:

Part Number	Description	Resolution (dpi)	Buttons	Tilt Wheel	Z-Wheel	Sensor Position	VID	PID	Mfg String	Product String
ADNS-5700-H3MB	Standard 3 buttons	1000	3	No	Mechanical	0°	0x192F	0x0416	Null	USB Optical Mouse
ADNS-5700-H3PB	Standard 3 buttons	1000	3	No	Optical	0°	0x192F	0x0416	Null	USB Optical Mouse
ADNS-5700-H4MB	Standard 3 buttons	1000	3	TW	Mechanical	0°	0x192F	0x0416	Null	USB Optical Mouse
ADNS-5700-H4PB	Standard 3 buttons	1000	3	TW	Optical	0°	0x192F	0x0416	Null	USB Optical Mouse
ADNS-5700-H5MD	Standard 5 buttons	1000	5	No	Mechanical	0°	0x192F	0x0616	Null	USB Optical Mouse
ADNS-5700-H5PD	Standard 5 buttons	1000	5	No	Optical	0°	0x192F	0x0616	Null	USB Optical Mouse
ADNS-5700-H3NB	Standard 3 buttons	1000	3	No	Mechanical	270°	0x192F	0x0416	Null	USB Optical Mouse
ADNS-5700-H3QB	Standard 3 buttons	1000	3	No	Optical	270°	0x192F	0x0416	Null	USB Optical Mouse
ADNS-5700-H4NB	Standard 3 buttons	1000	3	TW	Mechanical	270°	0x192F	0x0416	Null	USB Optical Mouse
ADNS-5700-H4QB	Standard 3 buttons	1000	3	TW	Optical	270°	0x192F	0x0416	Null	USB Optical Mouse
ADNS-5700-H5ND	Standard 5 buttons	1000	5	No	Mechanical	270°	0x192F	0x0616	Null	USB Optical Mouse
ADNS-5700-H5QD	Standard 5 buttons	1000	5	No	Optical	270°	0x192F	0x0616	Null	USB Optical Mouse

DISCLAIMER: ALL DESIGNERS AND MANUFACTURERS OF THIS DESIGN MUST ASSURE THAT THEY HAVE ALL NECESSARY INTELLECTUAL PROPERTY RIGHTS.

The XY motion reporting direction when is lens is attached to the sensor is shown in Fig 1b for 0° and Fig 1c for 270° sensor orientation.

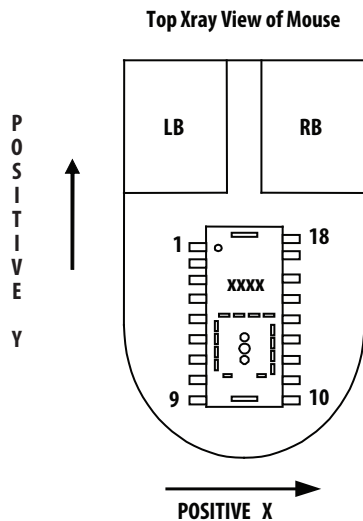

Figure 1b. Package pinout at 0°

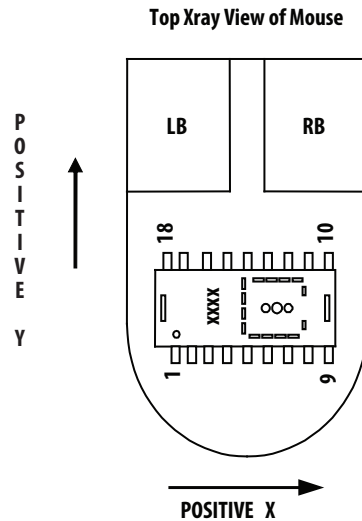

Figure 1c. Package pinout at 270°

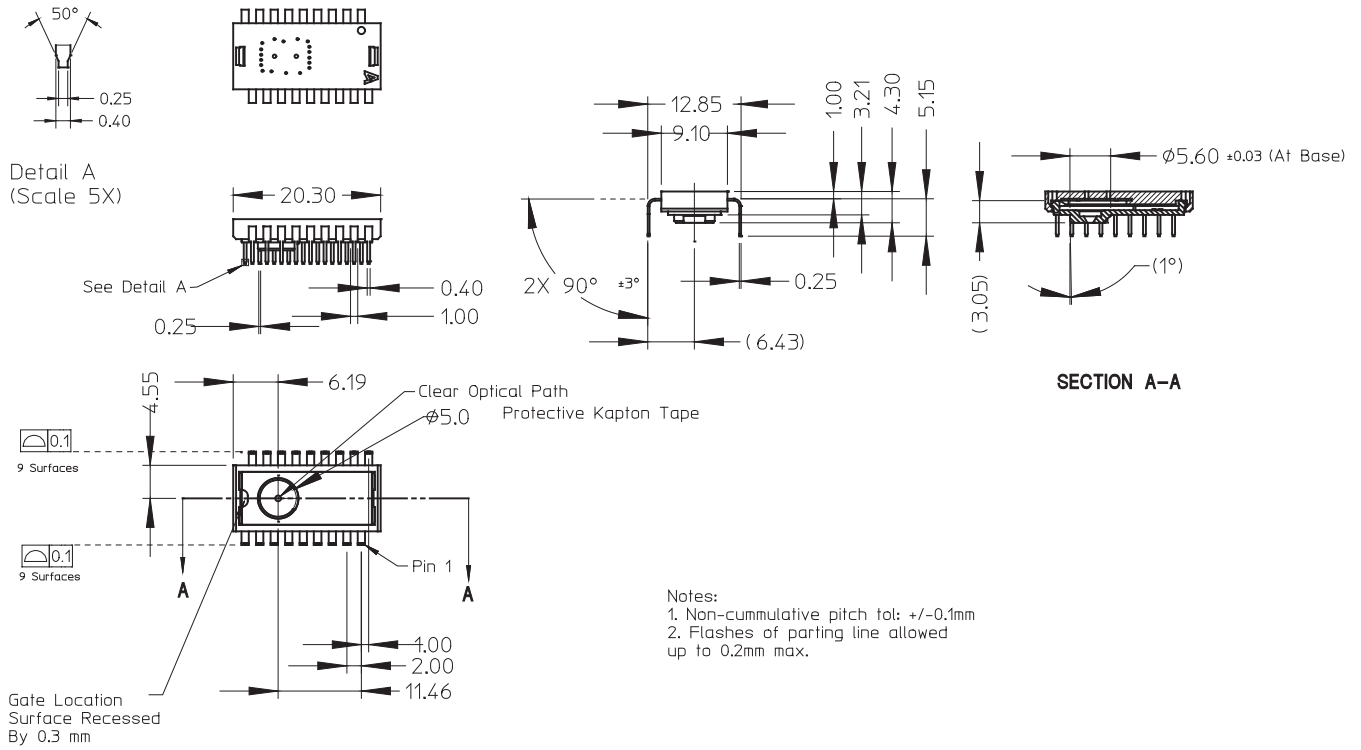
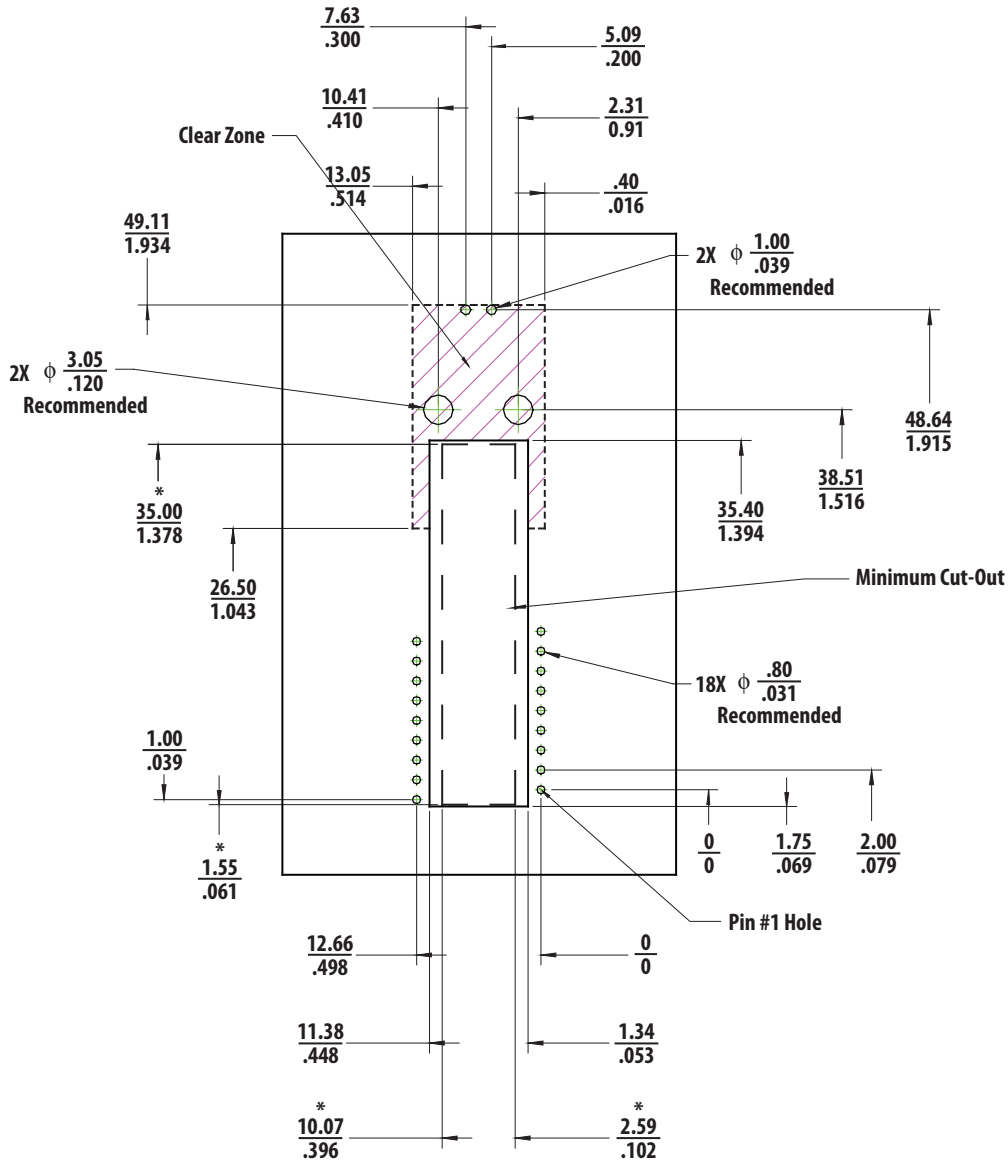

Figure 2. Package outline drawing

CAUTION: It is advised that normal static precautions be taken in handling and assembly of this component to prevent damage and/or degradation which may be induced by ESD.



Notes:

1. Dimensions in mm/inches.
2. *Indicates dimension for minimum cut-out.

Figure 3. Recommended PCB mechanical cutouts and spacing (Top view)

Note: The recommended pin hole dimension of the sensor is 0.7 mm. Shown with ADNS-5100 round lens, ADNS-5100-001 trim lens or ADNS-5100-002 truncated round lens, ADNS-5200 clip and HLMP-ED80-XX000

Avago Technologies provides an IGES file drawing describing the base plate molding features for lens and PCB alignment. Stand-off of the base plate shall not be larger than 5mm.

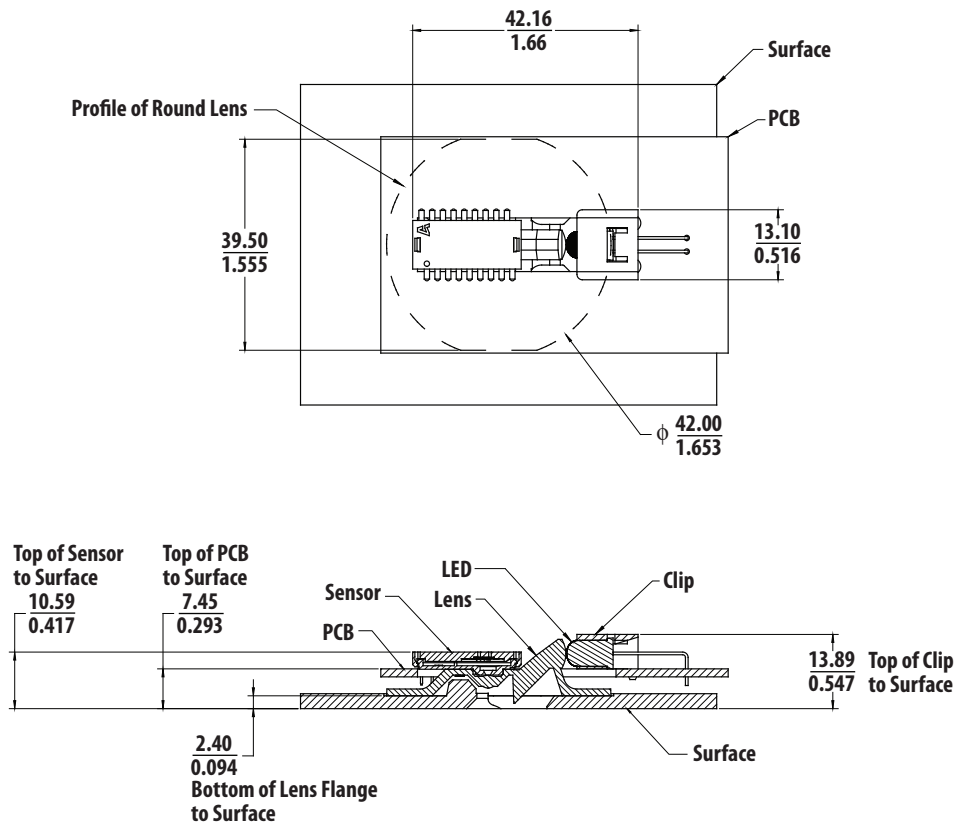

- Notes:
1. All dimensions in millimeters/inches.
 2. All tolerance ± 0.1 mm.

Figure 4. 2D assembly drawing of ADNS-5700-XXXX

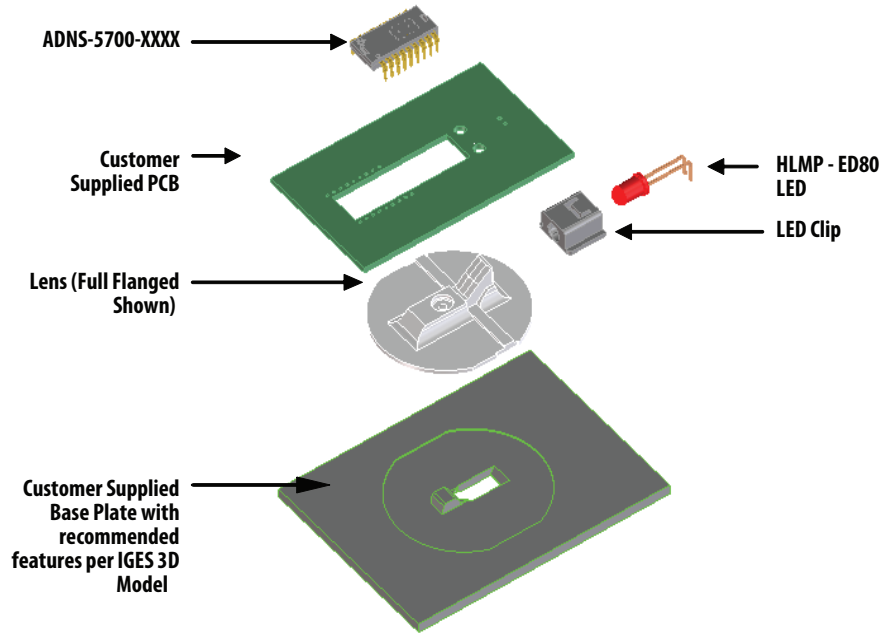

Figure 5. Exploded view drawing

The components interlock as they are mounted onto defined features on the base plate.

The ADNS-5700-XXXX sensor is designed for mounting on a through hole PCB, looking down. The aperture stop and features on the package align it to the lens (See figure 3).

The ADNS-5100 round lens, ADNS-5100-001 trim lens or ADNS-5100-002 truncated round lens provides optics for the imaging of the surface as well as illumination of the surface at the optimum angle. Lens features align it to the sensor, base plate, and clip with the LED.

The ADNS-5200 clip holds the LED in relation to the lens. The LED must be inserted into the clip and the LED's leads formed prior to loading on the PCB. The clip interlocks the sensor to the lens, and through the lens to the alignment features on the base plate.

The HLMP-ED80-XX000 LED is recommended for illumination.

Block Diagram

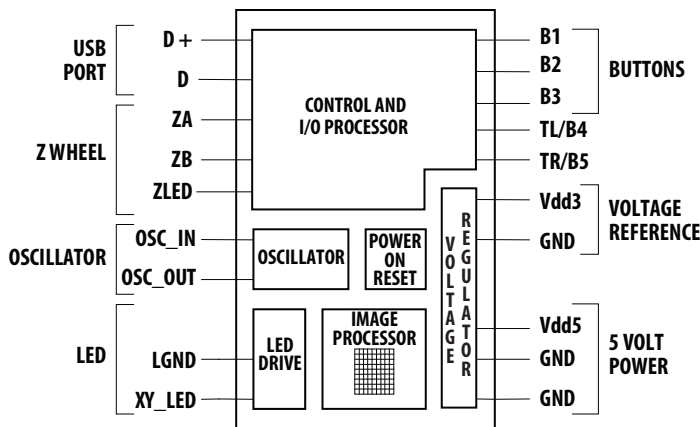

Figure 6. Block Diagram

PCB Assembly Considerations

1. Insert the sensor and all other electrical components into PCB.
2. Bend the LED leads 90 degrees and then insert the LED into the assembly clip until the snap feature locks the LED base.
3. Insert the LED/clip assembly into PCB.
4. Wave Solder the entire assembly in a no-wash solder process utilizing solder fixture. The solder fixture is needed to protect the sensor during the solder process. It also sets the correct sensor to PCB distance, as the lead shoulders do not normally rest on the PCB surface. The fixture should be designed to expose the sensor leads to solder while shielding the optical aperture from direct solder contact. A solder fixture **MUST** be used to set the correct sensor to PCB distance.
5. Place the lens onto the base plate.
6. Remove the protective Kapton tape from optical aperture of the sensor. Care must be taken to keep contaminants from entering the aperture. Recommend not placing the PCB facing up during the entire mouse assembly process. Recommend to hold the PCB first vertically for the Kapton removal process.
7. Insert PCB assembly over the lens onto base plate aligning post to retain PCB assembly. The sensor aperture ring should self-align to the lens.
8. The optical position reference for the PCB is set by the base plate and lens. Note that the PCB motion due to button presses must be minimized to maintain optical alignment.
9. Install mouse top case. There **MUST** be feature in the top case to press down onto the clip to ensure all components are interlocked to correct vertical height

Design considerations for improving ESD Performance

The table below shows typical values assuming base plate construction per the Avago Technologies supplied IGES file and ADNS-5100 round lens, ADNS-5100-001 trim lens and ADNS-5100-002 truncated round lens. Stand-off of the base plate shall not be larger than 5mm.

Typical Distance	ADNS-5100	ADNS-5100-001	ADNS-5100-002
Creepage	40.5mm	17.9mm	31.5mm
Clearance	32.6mm	9.2mm	17.9mm

Note that the lens material is polycarbonate or polystyrene HH30, therefore, cyanoacrylate based adhesives should not be used as they will cause lens material deformation

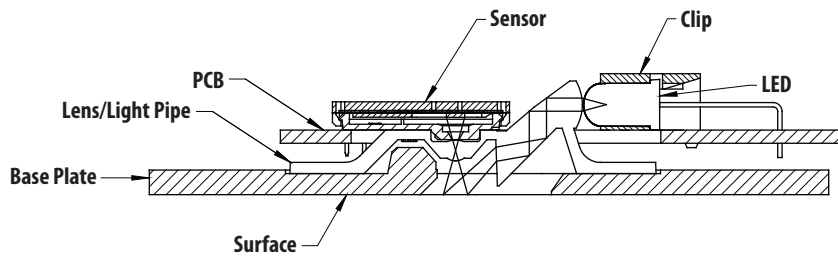

Figure 7. Typical Application

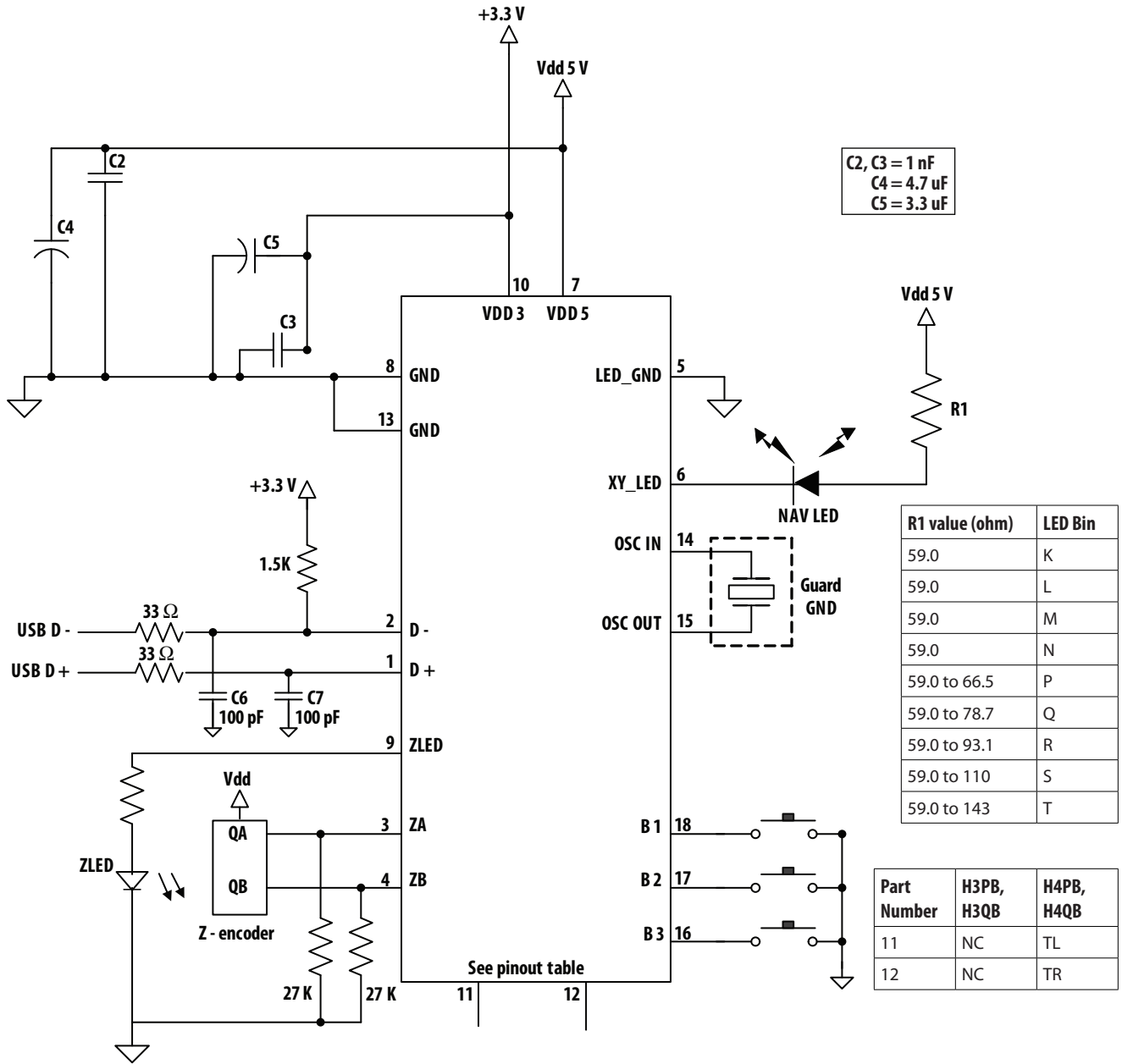

Figure 8a. Application Circuit with ADNS-5700-HxxB with Optical Z-Wheel

DISCLAIMER: ALL DESIGNERS AND MANUFACTURERS OF THIS DESIGN MUST ASSURE THAT THEY HAVE ALL NECESSARY INTELLECTUAL PROPERTY RIGHTS.

Notes:

- All caps (except C4) MUST be as close to the sensor pins as possible.
- C3 and C5 connected to pin 10 must be terminated at pin 13.
- Caps should be ceramic.
- Caps should have less than 5 nH of self inductance.
- Caps connected to VDD3 MUST have less than 0.2Ω ESR.
- 1.5k resistor should be ± 1% tolerance.

Surface mount parts are recommended.

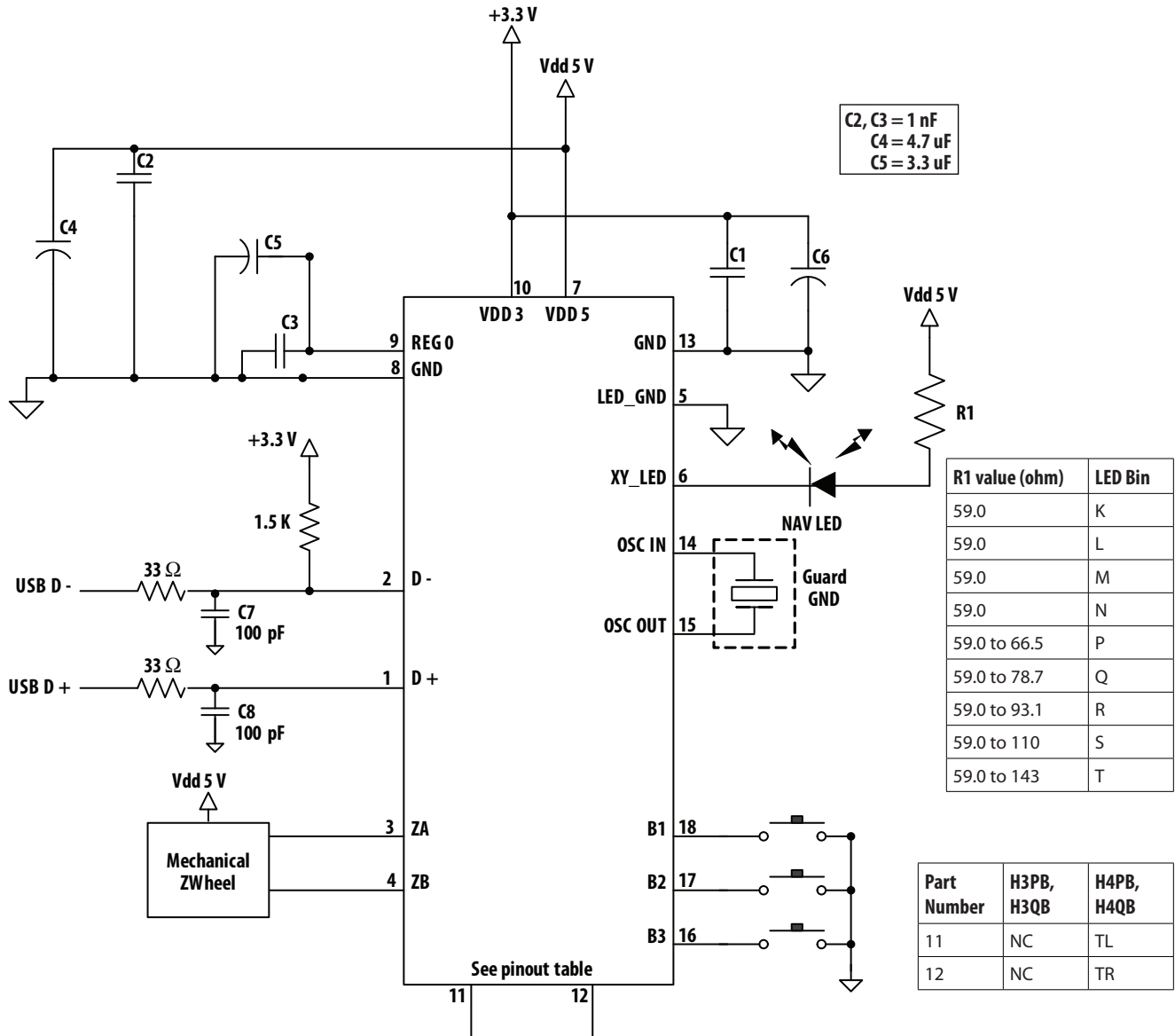

Figure 8b. Application Circuit with ADNS-5700-HxxB with Mechanical Z-Wheel

DISCLAIMER: ALL DESIGNERS AND MANUFACTURERS OF THIS DESIGN MUST ASSURE THAT THEY HAVE ALL NECESSARY INTELLECTUAL PROPERTY RIGHTS.

Notes:

- All caps (except C4) MUST be as close to the sensor pins as possible.
- C1 and C6 connected to pin 10 must be terminated at pin 13.
- C3 and C5 connected to pin 9 must be terminated at pin 8.
- Caps should be ceramic.
- Caps should have less than 5 nH of self inductance.
- Caps connected to VDD3 MUST have less than 0.2Ω ESR.
- 1.5k resistor should be ± 1% tolerance.

Surface mount parts are recommended.

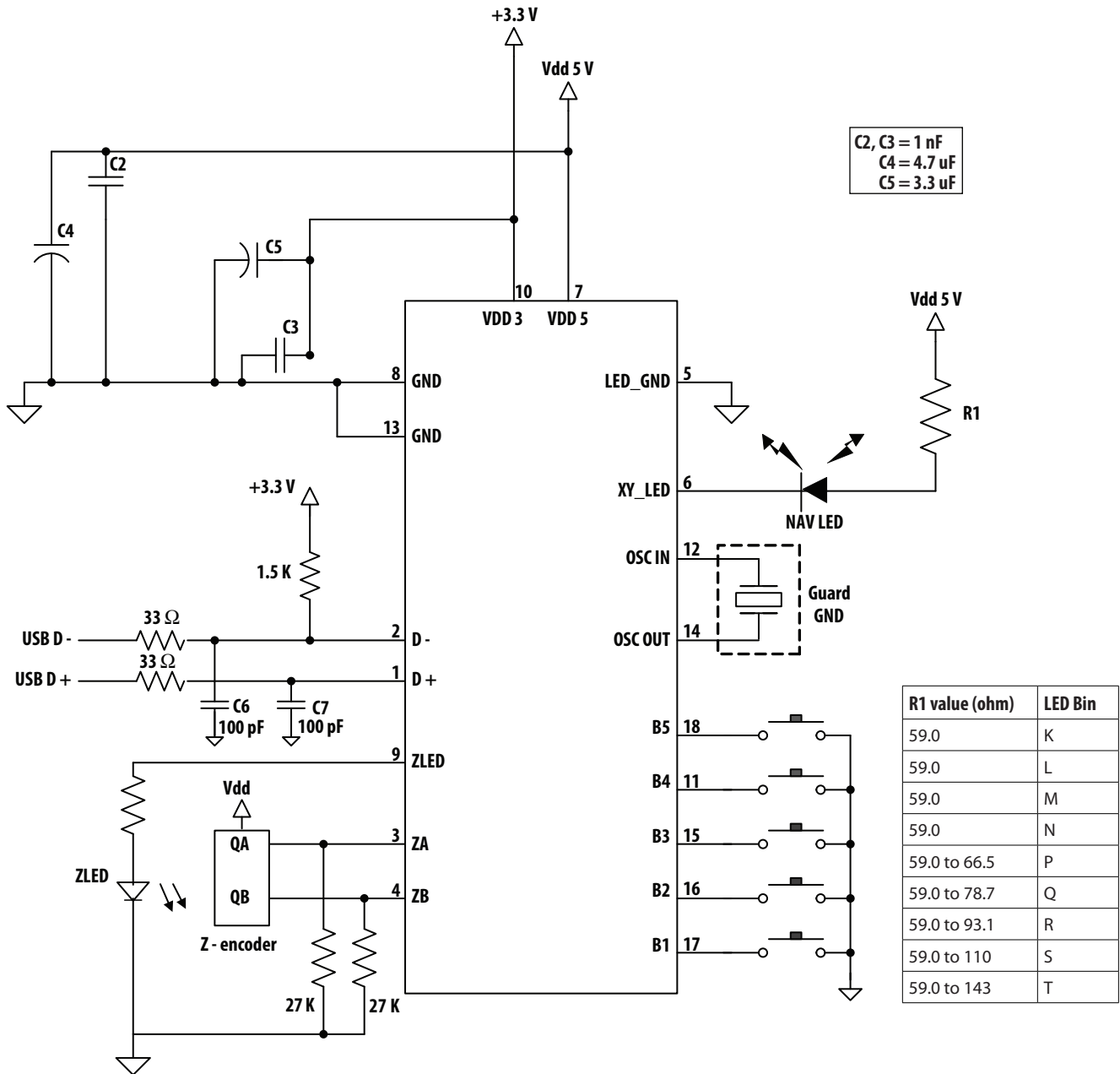

Figure 8c. Application Circuit ADNS-5700-HSPD and ADNS-5700-H5QD With 5 Button and Optical Z-Wheel

DISCLAIMER: ALL DESIGNERS AND MANUFACTURERS OF THIS DESIGN MUST ASSURE THAT THEY HAVE ALL NECESSARY INTELLECTUAL PROPERTY RIGHTS.

Notes:

- All caps (except C4) MUST be as close to the sensor pins as possible.
- C3 and C5 connected to pin 10 must be terminated at pin 8.
- Caps should be ceramic.
- Caps should have less than 5 nH of self inductance.
- Caps connected to V_{DD3} MUST have less than 0.2Ω ESR.
- 1.5k resistor should be ± 1% tolerance.

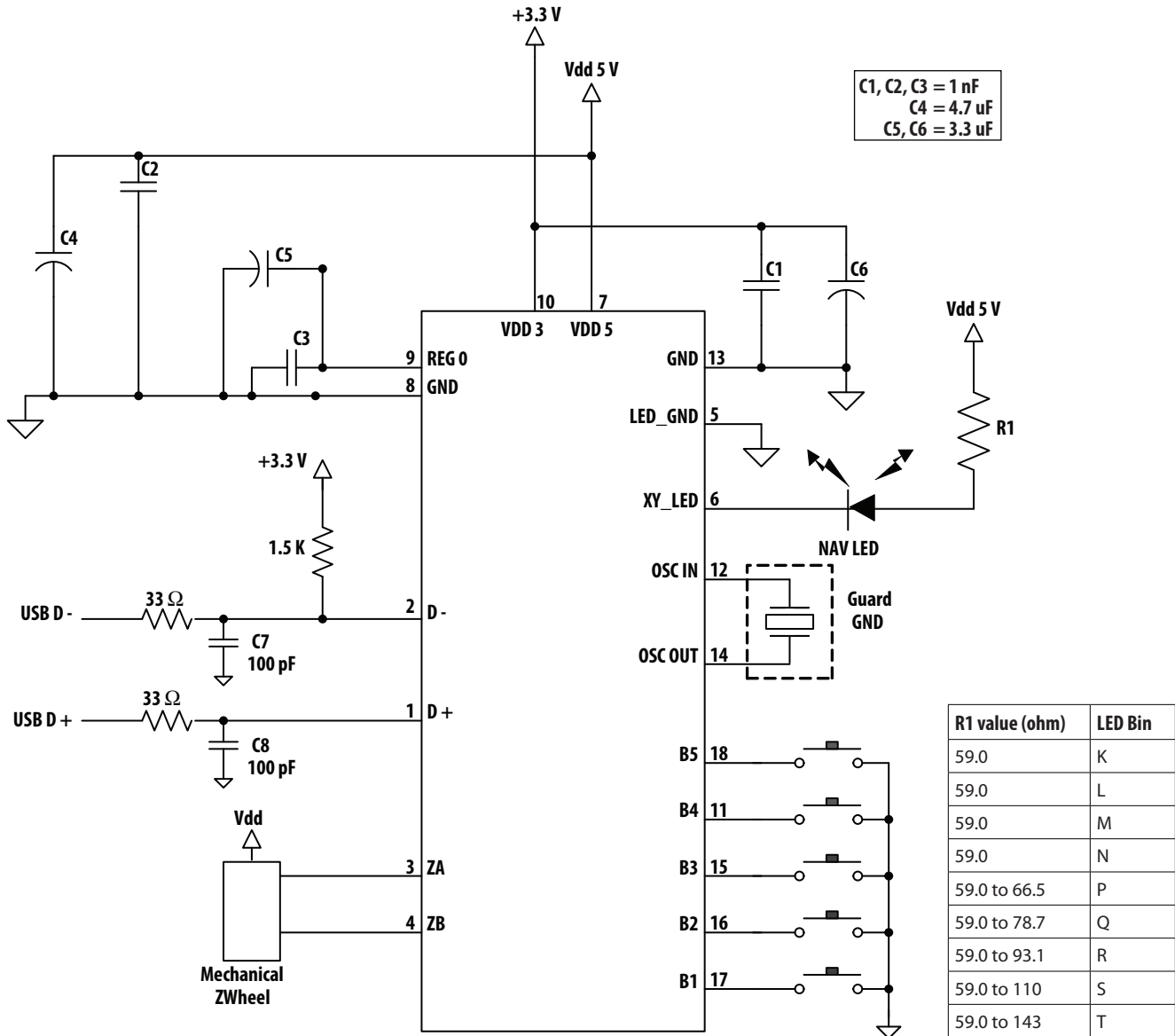

Figure 8d. Application Circuit with ADNS-5700-H5MD and ADNS-5700-H5ND with 5 Button and Mechanical Z-Wheel

DISCLAIMER: ALL DESIGNERS AND MANUFACTURERS OF THIS DESIGN MUST ASSURE THAT THEY HAVE ALL NECESSARY INTELLECTUAL PROPERTY RIGHTS.

Notes:

- All caps (except C4) MUST be as close to the sensor pins as possible.
- C1 and C6 connected to pin 10 must be terminated at pin 13.
- C3 and C5 connected to pin 9 must be terminated at pin 8.
- Caps should be ceramic.
- Caps should have less than 5 nH of self inductance.
- Caps connected to VDD3 MUST have less than 0.2Ω ESR.
- 1.5k resistor should be ± 1% tolerance.

Regulatory Requirements

- Passes FCC B and worldwide analogous emission limits when assembled into a mouse with shielded cable and following Avago Technologies recommendations.
- Passes EN61000-4-4/IEC801-4 EFT tests when assembled into a mouse with shielded cable and following Avago Technologies recommendations.
- UL flammability level UL94 V-0.
- Provides sufficient ESD creepage/clearance distance to withstand discharge up to 15kV when assembled into a mouse with ADNS-5100 round lens according to usage instructions above.

Absolute Maximum Ratings

Parameter	Symbol	Minimum	Maximum	Units	Notes
Storage Temperature	T _S	-40	85	°C	
Operating Temperature	T _A	-15	55	°C	
Lead Solder Temp			260	°C	For 7 seconds, 1.6mm below seating plane.
Supply Voltage	V _{DD}	-0.5	5.5	V	
ESD			2	kV	All pins, JESD22-A114
Input Voltage	V _{IN}	-0.5	V _{DD} +0.5	V	All I/O pins except OSC_IN and OSC_OUT, D+, D-
Input Voltage	V _{IN}	-1.0	4.6	V	D+, D-, AC waveform, see USB specification (7.1.1)
Input Voltage	V _{IN}	-0.5	3.6	V	OSC_IN and OSC_OUT
Input Short Circuit Voltage	V _{SC}	0	V _{DD}	V	D+, D-, see USB specification (7.1.1)

Recommended Operating Conditions

Parameter	Symbol	Minimum	Typical	Maximum	Units	Notes
Operating Temperature	T _A	0		40	°C	
Power supply voltage	V _{DD}	4.25	5.0	5.25	Volts	For accurate navigation and proper USB operation
Power supply voltage	V _{ddm}	4	5.0	5.25	Volts	Maintains communication to USB host and internal register contents.
Power supply rise time	V _{RT}	0.003		100	ms	
Supply noise	V _N			100	mV	Peak to peak within 0-80 MHz bandwidth
Velocity	Vel		30		ips	
Acceleration	Acc			8	g	0.5g from Rest
Clock Frequency	f _{clk}	23.64	24	24.36	MHz	Due to USB timing constraints
Resonator Impedance	X _{RES}			55	Ω	
Distance from lens reference plane to surface	Z	2.3	2.4	2.5	mm	See Figure 9
Frame Rate			4000		fps	Internally adjusted by sensor

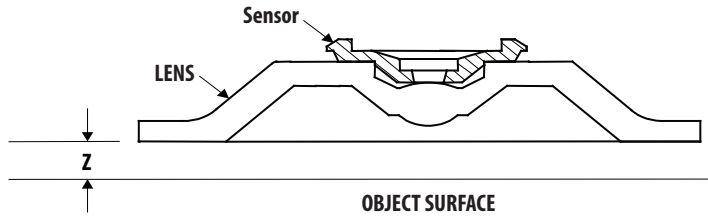

Figure 9. Distance from lens reference plane to object surface

AC Electrical Specifications

Electrical Characteristics over recommended operating conditions. Typical values at 25°C, $V_{DD}=5.0\text{ V}$

Parameter	Symbol	Min.	Typical	Max.	Units	Notes
Wakeup delay from rest mode due to motion.	T_{WUPP}			2	ms	
Power up delay	T_{PUP}			50	ms	
Debounce delay on button inputs	T_{DBB}	5	10	17	ms	“Maximum” specified at 8ms polling rate.
Scroll wheel sampling period	T_{SW}	150	200	300	μs	ZA PIN for optical scroll wheel
		1.9	2.0	2.8	ms	ZA PIN for mechanical scroll wheel
Transient Supply Current	I_{DDT}			60	mA	Max. supply current during a V_{DD} ramp from 0 to 5.0 V with > 500 μs rise time. Does not include charging currents for bypass capacitors.
Input Capacitance (OSC Pins)	C_{OSC_IN}		50		pF	OCS_IN, OSC_OUT to GND

USB Electrical Specifications

Electrical Characteristics over recommended operating conditions.

Parameter	Symbol	Min.	Max.	Units	Notes
Output Signal Crossover Voltage	V_{CRS}	1.5	2.0	V	$C_L = 200$ to 600 pF (see Figure 10)
Input Signal Crossover Voltage	V_{ICRS}	1.2	2.1	V	$C_L = 200$ to 600 pF (see Figure 10)
Output High	V_{OH}	2.8	3.6	V	with 15 kohm to Ground and 7.5 k Ω to Vbus on D- (see Figure 11)
Output Low	V_{OL}	0.0	0.3	V	with 15 kohm to Ground and 7.5 k Ω to Vbus on D- (see Figure 11)
Single Ended Input	V_{SEI}		0.8	V	
Input High (Driven)	V_{IH}	2.0		V	
Input High (Floating)	V_{IHZ}	2.7	3.6	V	
Input Low	V_{IL}		0.8	V	7.5k Ω to V_{DD5}
Differential Input Sensitivity	V_{DI}	0.2		V	$ (D+)-(D-) $ See Figure 12
Differential Input Common Mode Range	V_{CM}	0.8	2.5	V	Includes V_{DI} , See Figure 12
Single Ended Receiver Threshold	V_{SE}	0.8	2.0	V	
Transceiver Input Capacitance	C_{IN}		12	pF	D+ to V_{BUS} , D- to V_{BUS}

USB Timing Specifications

Timing Specifications over recommended operating conditions.

Parameter	Symbol	Min.	Max.	Units	Notes
D+/D- Transition rise time	T_{LR}	75		ns	$C_L = 200$ pF (10% to 90%), see Figure 10
D+/D- Transition rise time	T_{LR}		300	ns	$C_L = 600$ pF (10% to 90%), see Figure 10
D+/D- Transition fall time	T_{LF}	75		ns	$C_L = 200$ pF (90% to 10%), see Figure 10
D+/D- Transition fall time	T_{LF}		300	ns	$C_L = 600$ pF (90% to 10%), see Figure 10
Rise and Fall time matching	T_{LRFM}	80	125	%	T_R/T_F ; $C_L = 200$ pF; Excluding the first transition from the Idle State
Wakeup delay from USB suspend mode due to buttons push	T_{WUPB}		17	ms	Delay from button push to USB operation Only required if remote wakeup enabled
Wakeup delay from USB suspend mode due to buttons push until accurate navigation	T_{WUPN}		50	ms	Delay from button push to navigation operation Only required if remote wakeup enabled
USB reset time	T_{reset}	18.7		μ s	
Data Rate	t_{LDRATE}	1.4775	1.5225	Mb/s	Average bit rate, 1.5 Mb/s +/- 1.5%
Receiver Jitter Tolerance	t_{DJR1}	-75	75	ns	To next transition, see Figure 13
Receiver Jitter Tolerance	t_{DJR2}	-45	45	ns	For paired transitions, see Figure 13
Differential to EOP Transition Skew	t_{LDEOP}	-40	100	ns	See Figure 14
EOP Width at Receiver	t_{LEOPR}	670		ns	Accepts EOP, see Figure 14
Source EOP Width	t_{LEOPT}	1.25	1.50	μ s	
Width of SE0 interval during Differential Transition	t_{LST}		210	ns	See Figure 11
Differential Output Jitter	t_{UDJ1}	-95	95	ns	To next transition, see Figure 15
Differential Output Jitter	t_{UDJ2}	-150	150		For paired transitions, see Figure 15

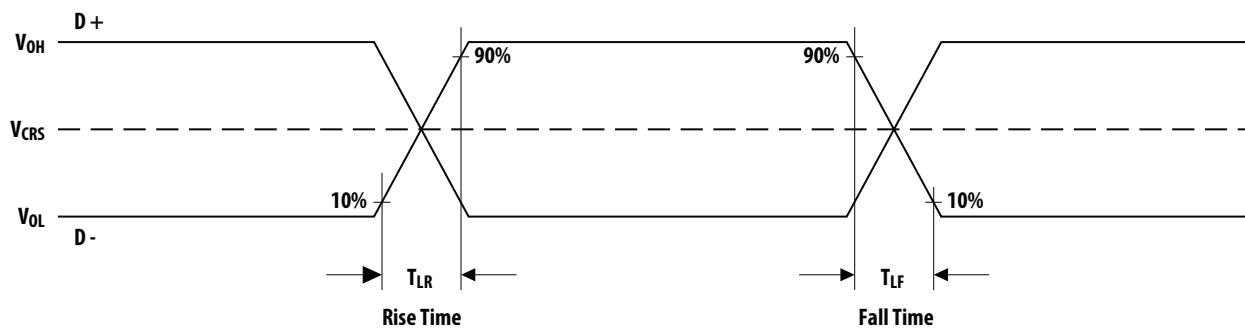

Figure 10. Data Signal Rise and Fall Times

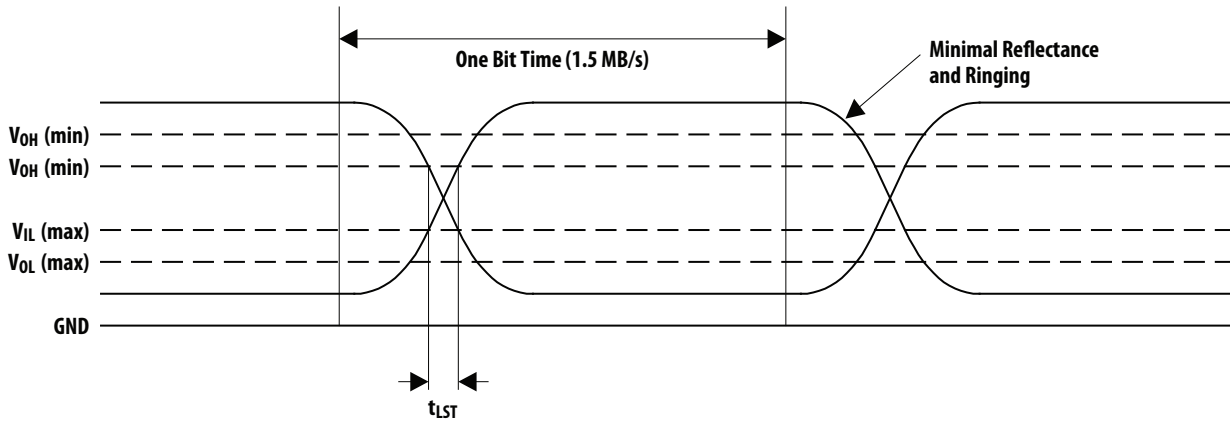

Figure 11. Data Signal Voltage Levels

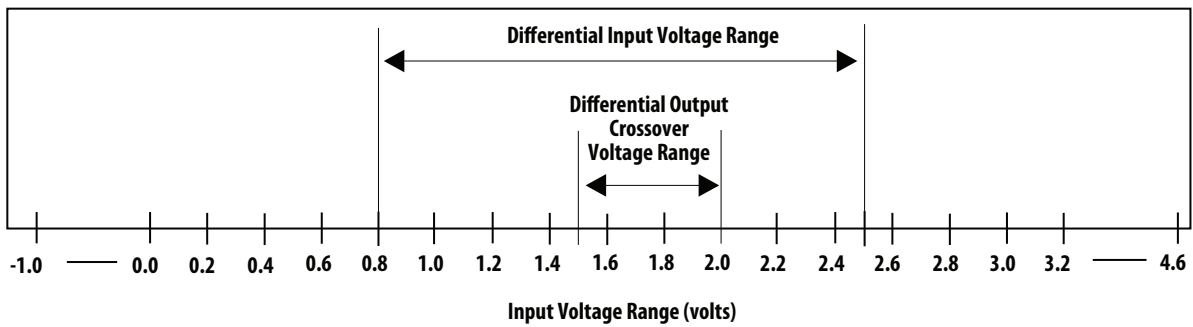

Figure 12. Differential Receiver Input Sensitivity vs. Common Mode Input Range

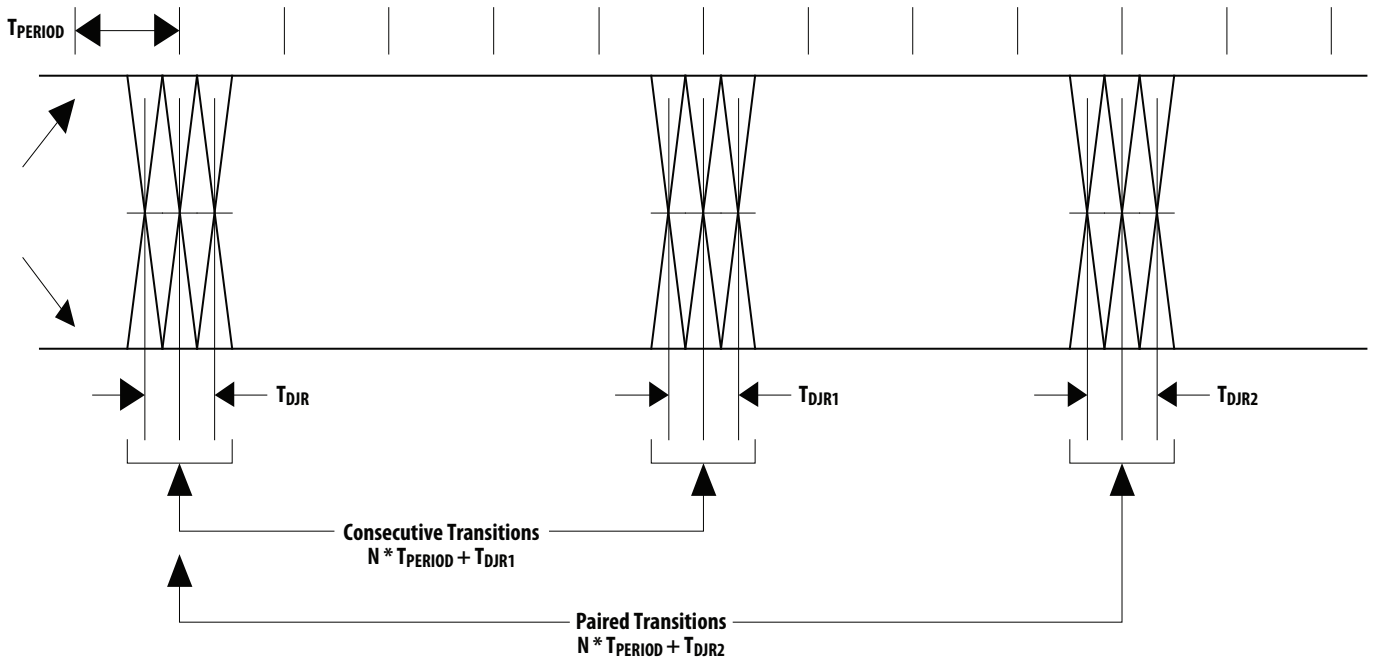

Figure 13. Receiver Jitter Tolerance

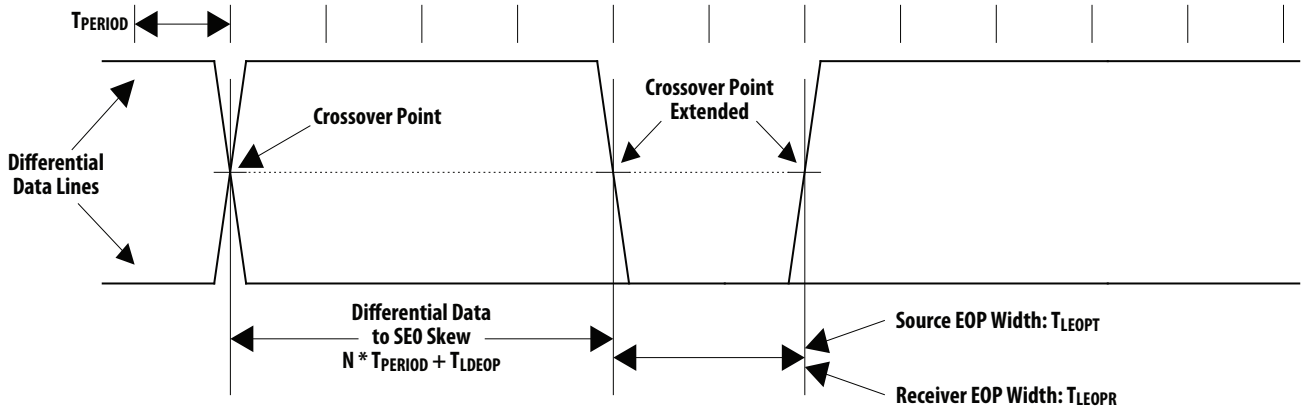

Figure 14. Differential to EOP Transition Skew and EOP Width

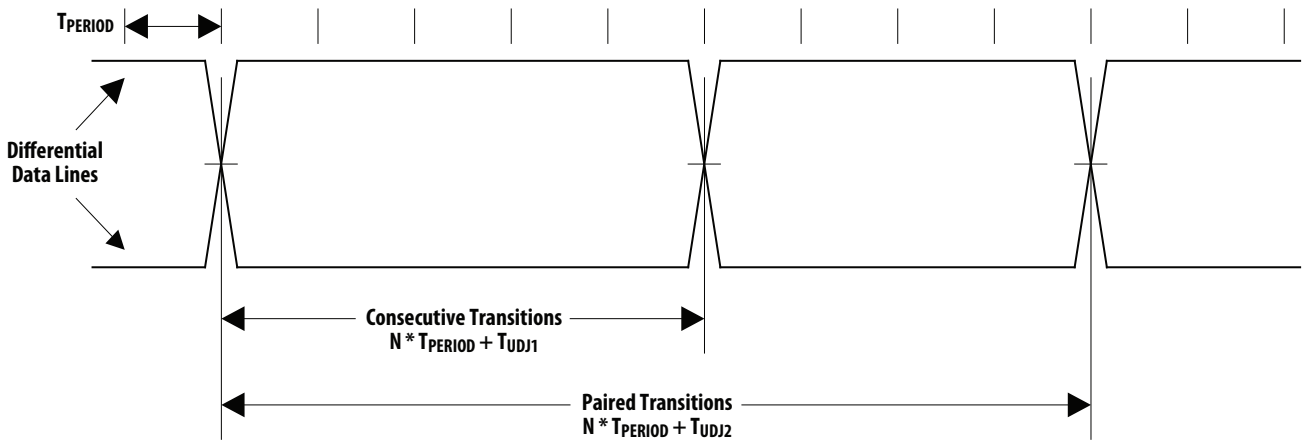

Figure 15. Differential Output Jitter

DC Electrical Specifications

Electrical Characteristics over recommended operating conditions. Typical values at 25°C, V_{DD}=5.0 V.

Parameter	Symbol	Minimum	Typical	Maximum	Units	Notes
System Current, mouse moving	I _{DD5}			100	mA	Includes XY_LED current
System Current, mouse not moving	I _{DD5N}			100	mA	Includes XY_LED current
System current, USB suspend mode, Remote Wakeup Enabled	I _{DD5S}			500	μA	Includes XY_LED current and D- pullup resistor.
Supply current (Sensor only), mouse moving	I _{DD5}		12	15	mA	No load on B1-B5, XY-LED, ZA, ZB, D+, D-
Supply current (Sensor only), mouse not moving	I _{DD5N}		11	14	mA	No load on B1-B5, XY-LED, ZA, ZB, D+, D-
Sensor supply current, USB suspend mode	I _{DD5S}			260	μA	No load on B1-B5, XY-LED, ZA, ZB, D+,D-
XY_LED current	I _{LED}		40	49	mA	Typical at R _{bin} 59ohm with binP LED. Maximum DC current allowed through XY_LED pin and LED.
XY_LED Output Low Voltage	V _{OL}			1.1	V	Refer to Figure 16
Input Low Voltage	V _{IL}			0.5	V	Pins: ZA, ZB, B1-B5, V _{IL} max of 0.5V _{DC} is at V _{DD} min of 4V _{DC} , with a typical of 0.8V _{DC} at V _{DD} of 5V _{DC}
Input High Voltage	V _{IH}	0.6*V _{DD}			V	Pins: ZA, ZB, B1-B5
Input Hysteresis	V _{HYST}		285		mV	Pins: B1-B5, OPT 0, OPT 1
Button Pull Up Current	B _{IOUT}	125	275	500	μA	Pins: B1-B5, OPT 0, OPT 1

Buttons

The minimum time between button presses is T_{DBB}. Buttons B1 through B5 are connected to a Schmidt trigger input with 100 uA current sources pulling up to +3 volts during normal, sleep and USB suspend modes.

Debounce Algorithm

- Button inputs B1, B2, B3, B4, B5 are sampled every 2ms.
- Three consecutive low create a button press event.
- Three consecutive high create a button release event.

Typical Performance Characteristics

Performance Characteristics over recommended operating conditions. Typical values at 25 °C, V_{DD}=5.0 V, 24MHz

Parameter	Symbol	Minimum	Typical	Maximum	Units	Notes
Path Error (Deviation)	P _{Error}		0.5		%	Average path error as percent of total 2.5" travel on various standard surfaces

The following graphs are the typical performance of the ADNS-5700-XXXX sensor, assembled as shown in the 2D assembly drawing with the ADNS-5100 round Lens or ADNS-5100-001 trim lens/Prism, the ADNS-5200 clip, and the HLMP-ED80-XX000 LED.

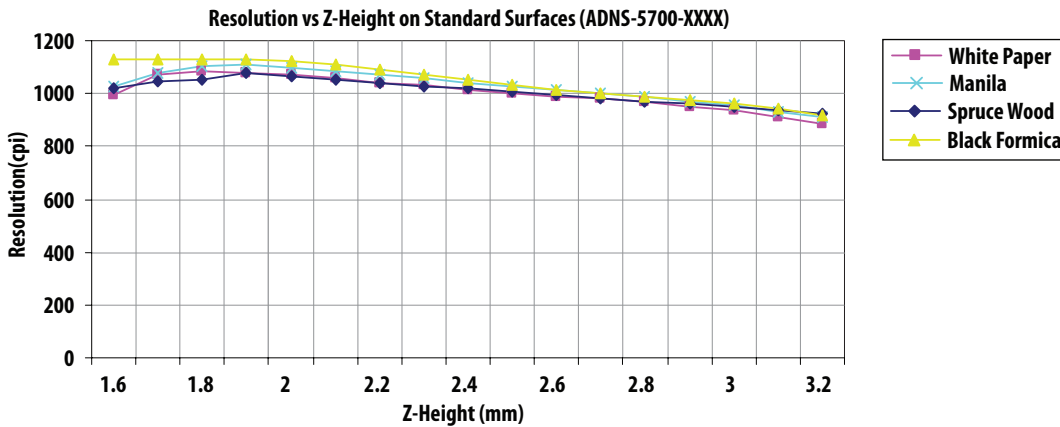

Figure 16. Typical Resolution vs. Z Height

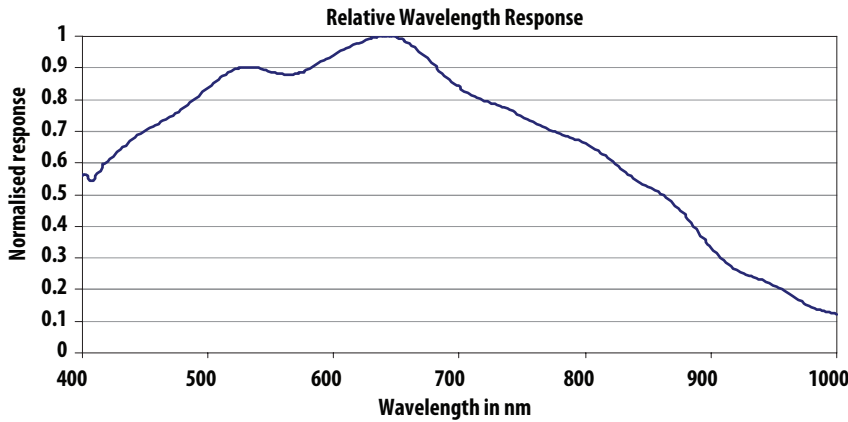

Figure 17. Wavelength responsivity,^[1] (Comparative Surfaces)

Note:

1. The ADNS-5700-XXXX is designed for optimal performance when used with the HLMP-ED80-XX000 (Red LED 639nm).
2. Z = distance from Lens Reference Plane to Surface.
3. DOF = Depth of Field

Configuration after Power up (Data Values)

Signal Function	State from Figure 9-1 of USB spec: Powered or Default Address or Configured	State from Figure 9-1 of USB spec: Suspended from any other state
B1	V _{DD3} or GND if used as VID/PID jumper else pullup active for button use	V _{DD3} or GND if used as VID/PID jumper else pullup active for button use
B2	V _{DD3} or GND if used as VID/PID jumper	V _{DD3} or GND if used as VID/PID jumper
B3	V _{DD3} or GND if used as VID/PID jumper	V _{DD3} or GND if used as VID/PID jumper
B4	V _{DD3} or GND if used as VID/PID jumper else pullup active for button use	V _{DD3} or GND if used as VID/PID jumper else pullup active for button use
B5	V _{DD3} or GND if used as VID/PID jumper else pullup active for button use	V _{DD3} or GND if used as VID/PID jumper else pullup active for button use
D-	USB I/O	Hi-Z input
D+	USB I/O	Hi-Z input
OSC_IN	24MHz	Logic '1'
OSC_OUT	24MHz	Logic '1'
XY_LED	Always ON / Pulsing	Pulled high (off)
ZB	Hi-Z input	Hi-Z input
ZA	Hi-Z if ZA tied to GND	Hi-Z input
Z_LED	Hi-Z input	Hi-Z input

USB Commands

Mnemonic	Command	Notes
USB_RESET	D+/D- low > 18.7us	Device Resets; Address=0
USB_SUSPEND	Idle state > 3mS	Device enters USB low-power mode
USB_RESUME	Non-idle state	Device exits USB low-power mode
Get_Status_Device	80 00 00 00 00 00 02 00	Normally returns 00 00, Self powered 00 00, Remote wakeup 02 00
Get_Status_Interface	81 00 00 00 00 00 02 00	Normally returns 00 00
Get_Status_Endpt0	82 00 00 00 xx 00 02 00	OUT: xx=00, IN: xx=80 Normally returns 00 00
Get_Status_Endpt1	82 00 00 00 81 00 02 00	Normally returns 00 00, Halt 00 01
Get_Configuration	80 08 00 00 00 00 01 00	Return: 00=not config., 01=configured
Get_Interface	81 0A 00 00 00 00 01 00	Normally returns 00
Get_Protocol	A1 03 00 00 00 00 01 00	Normally returns 01, Boot protocol 00
Get_Desc_Device	80 06 00 01 00 00 nn 00	See USB command details
Get_Desc_Config	80 06 00 02 00 00 nn 00	See USB command details
Get_Desc_String	80 06 xx 03 00 00 nn 00	See USB command details
Get_Desc_HID	81 06 00 21 00 00 09 00	See USB command details
Get_Desc_HID_Report	81 06 00 22 00 00 nn 00	See USB command details
Get_HID_Input	A1 01 00 01 00 00 nn 00	Return depends on motion & config
Get_Idle	A1 02 00 00 00 00 01 00	Returns rate in multiples of 4ms
Get_Vendor_Test	C0 01 00 00 xx 00 01 00	Read register xx
Set_Address	00 05 xx 00 00 00 00 00	xx = address
Set_Configuration	00 09 xx 00 00 00 00 00	Not configured: xx=00 Configured: xx=01
Set_Interface	01 0B 00 00 00 00 00 00	Only one interface supported
Set_Protocol	21 0B xx 00 00 00 00 00	Boot: xx=00, Report: xx=01
Set_Feature_Device	00 03 01 00 00 00 00 00	Enable remote wakeup
Set_Feature_Endpt0	02 03 00 00 xx 00 00 00	Halt. OUT: xx=00, IN: xx=80
Set_Feature_Endpt1	02 03 00 00 81 00 00 00	Halt
Clear_Feature_Device	00 01 01 00 00 00 00 00	Disable Remote wakeup
Clear_Feature_Endpt0	02 01 00 00 xx 00 00 00	Clear Halt; OUT: xx=00, IN: xx=80
Clear_Feature_Endpt1	02 01 00 00 81 00 00 00	Clear Halt
Set_Idle	21 0A 00 rr 00 00 00 00	rr = report rate in multiples of 4ms
Set_Vendor_Test	40 01 00 00 xx yy 00 00	Write yy to address xx
Poll_Endpt1		Read buttons, motion, & Z-wheel

Note:

The last two bytes in a command shown as "nn 00" specify the 16-bit data size in the order of "LowByte HighByte." For example a two-byte data size would be specified as "02 00." ADNS-5700-XXXX will not provide more bytes than the number requested in the command, but it will only supply up to a maximum of 8 bytes at a time. The ADNS-5700-XXXX will re-send the last packet if the transfer is not acknowledged properly.

USB COMMAND DETAILS

USB_RESET	D+/D- low for an extended period
USB Spec:	A device may reset after seeing an SE0 for more than 18.7 uS, and definitely after 10mS.
Notes:	After power up and prior to Reset, the device will not respond to any USB commands. After the device has been given a USB Reset, the device's address will be reset to zero and the device will be in the Default state. The chip will default to Report protocol and any pending output will be flushed. All registers will be reset to a state that matches power-on-reset with the following exceptions: USB State register will be "Default" instead of "Attached".
USB_SUSPEND	Idle state for an extended period
USB Spec:	A device may suspend after seeing an idle for more than 3mS, and definitely after 10mS.
Notes:	The chip will take a minimum of 5mS to start Suspend, though will definitely start after 6mS. The chip may finish the current frame if necessary before stopping the clock. Thus, an additional frame time may be used to reach Suspend mode.
USB_RESUME	Non-idle state
USB Spec:	Remote Resume signalling from a device must be between 1mS and 15mS. The host is required to send Resume signaling for 20mS plus 10mS of resume recovery time in which it does not access any devices. This allows devices enough time to wake back up.
Notes:	The chip can cause a Resume if Remote Wakeup is enabled and a button has been pressed. Remote resume signalling from the chip will last 11.45mS to 12.45mS.
Get_Status_Device	80 00 00 00 00 00 02 00
Returns:	xx yy xx[0] = Self Powered xx[1] = Remote Wakeup xx[7:2] = 0 yy = 00 (Reserved)
Default:	Accept (undefined in USB Spec)
Addressed:	Accept
Configured:	Accept
Notes:	Use Set_Feature_Device/Clear_Feature_Device to set/clear remote wakeup.
Get_Status_Interface	81 00 00 00 00 00 02 00
Returns:	00 00
Default:	Stall (undefined in USB Spec)
Addressed:	Stall
Configured:	Accept
Notes:	Both return bytes are reserved and currently 00.

Get_Status_Endpt0	82 00 00 00 xx 00 02 00 82 00 00 00 00 00 02 00 82 00 00 00 80 00 02 00 xx = 00 = Endpt0 OUT xx = 80 = Endpt0 IN
Returns:	xx yy xx[0] = Halt xx[7:1] = 0 yy = 00 (Reserved)
Default:	Accept (undefined in USB Spec)
Addressed:	Accept
Configured:	Accept
Notes:	Use Set_Feature_Endpt0/Clear_Feature_Endpt0 to (try to) set/clear Halt bit. According to USB, "It is neither required or recommended that the Halt feature be implemented for the Default Control Pipe." Since a new SETUP command will clear any Endpt0 halt bit, it is impossible to tell if there really is a halt bit.

Get_Status_Endpt1	82 00 00 00 81 00 02 00
Returns:	xx yy xx[0] = Halt xx[7:1] = 0 yy = 00 (Reserved)
Default:	Stall (undefined in USB Spec)
Addressed:	Stall
Configured:	Accept
Notes:	Use Set_Feature_Endpt1/Clear_Feature_Endpt1 to set/clear Halt bit.

Get_Configuration	80 08 00 00 00 00 01 00
Returns:	xx xx = config value
Default:	Accept (undefined in USB Spec) – returns 00
Addressed:	Accept – returns 00
Configured:	Accept – returns 01
Notes:	Use Set_Configuration to change.

Get_Interface	81 0A 00 00 00 00 01 00
Returns:	00
Default:	Stall (undefined in USB Spec)
Addressed:	Stall
Configured:	Accept – returns 00
Notes:	Command has no alternate interfaces, so only valid value is 00

Get_Protocol	A1 03 00 00 00 00 01 00
Returns:	xx xx = 00 = Boot protocol xx = 01 = Report protocol
Default:	Accept
Addressed:	Accept
Configured:	Accept
Notes:	Defaults to Report protocol after USB Reset. Use Set_Protocol to change.

Get_Desc_Device	80 06 00 01 00 00 nn 00 80 06 00 01 00 00 12 00
Returns:	12 01 00 02 00 00 00 08 vv vv pp pp dd dd mm PP ss 01 vv vv = vendor id pp pp = product id (vendor specified) dd dd = device id (vendor specified) (bcd rev_id byte) mm = iManufacturer PP = iProduct ss = iSerialNumber (00 - no string)
Default:	Accept
Addressed:	Accept
Configured:	Accept Get_Desc_String will return "stall" if Manufacturer string is queried when iManufacturer = 0x00.

```

Get_Desc_Config 80 06 00 02 00 00 nn 00
                80 06 00 02 00 00 22 00

Returns:        09 02 22 00 01 01 00 A0
                32 09 04 00 00 01 03 01
                02 00 09 21 11 01 00 01
                22 rr 00 07 05 81 03 05
                00 0A
                rr = HID Report descriptor length
                47 = 12 bit motion reporting

With Z-Wheel:  09 02 22 00 01 01 00 A0
                32 09 04 00 00 01 03 01
                02 00 09 21 11 01 00 01
                22 3D 00 07 05 81 03 04
                00 0A
                // Config Descriptor
                | 09 // bLength
                | 02 // bDescriptorType
                | 22 // wTotalLength (34 decimal)
                | 00 // high byte of WTotalLength
                | 01 // bNumInterfaces
                | 01 // bConfigurationValue
                | 00 // iConfiguration
                | A0 // bmAttributes (bus powered/remote wakeup)
                | 32 // MaxPower (in 100mA in 2mA units)
                // Interface Descriptor
                | 09 // bLength
                | 04 // bDescriptorType
                | 00 // bInterfaceNumber
                | 00 // bAlternateSetting
                | 01 // bNumEndpoints
                | 03 // bInterfaceClass (HID Class)
                | 01 // bInterfaceSubClass
                | 02 // bInterfaceProtocol
                | 00 // iInterface
                // HID Descriptor
                | 09 // bLength
                | 21 // bDescriptorType
                | 11 // bcdHID ( HID Release ###.###; HID 1.11 compliant )
                | 01 //
                | 00 // bCountry
                | 01 // bAvailable
                | 22 // bType
                | 34 // wLength (Length of HID Report below)
                | 00 //
                // Endpoint Descriptor
                | 07 // bLength
                | 05 // bDescriptorType
                | 81 // bEndpointAddress (IN & #=1)
                | 03 // bmAttributes (Interrupt)
                | 05 // wMaxPacketSize
                | 00 // 12bit 0x06
                | 0A // bInterval (10mS)

```

Default: Accept
 Addressed: Accept
 Configured: Accept
 Notes: This is the concatenation of 4 descriptors:
 Configuration
 Interface
 HID
 Endpt

Get_Desc_String 80 06 xx 03 00 00 nn 00
 xx= 00 Language String
 01 Manufacturer String
 02 Product String

Returns: ss 03 „unicode string“
 ss = String descriptor length

These values are determined by jumper configuration on page xx:

For xx=00: 04 03 09 04 // Language ID

For xx=01: return "stall" if Manufacturer string is queried when iManufacturer = 0x00. See Get_Desc_Device section

For xx=02: 24 03 55 00 53 00 42 00 // "USB"
 20 00 4f 00 70 00 74 00 // "Opt"
 69 00 63 00 61 00 6c 00 // " ical"
 20 00 4d 00 6f 00 75 00 // "Mou"
 73 00 65 00 // "se"

Default: Accept
 Addressed: Accept
 Configured: Accept
 Notes: A request for any other string will STALL.

Get_Desc_HID 81 06 00 21 00 00 09 00

Returns: 09 21 11 01 00 01 22 rr 00
 rr = HID Report descriptor length
 47 = 12 bit motion

Default: Accept
 Addressed: Accept
 Configured: Accept

Get_Desc_HID_Report 81 06 00 22 00 00 nn 00

Returns: This returns a report descriptor that describes how many buttons and x, y, z data.

These values are determined by jumper configuration see table on page 4:

With Tilt wheel and 12bit reporting: 05 01 09 02 A1 01 09 01
A1 00 05 09 19 01 29 05
15 00 25 01 75 01 95 05
81 02 75 03 95 01 81 01
05 01 09 30 09 31 16 01
F8 26 FF 07 75 0C 95 02
81 06 09 38 15 81 25 7F
75 08 95 01 81 06 05 0C
0A 38 02 81 06 C0 C0
// HID Report
| 05 01 // USAGE_PAGE (Generic Desktop)
| 09 02 // USAGE (Mouse)
| A1 01 // COLLECTION (Application)
| 09 01 // USAGE (Pointer)
| A1 00 // COLLECTION (Physical)
| 05 09 // USAGE_PAGE (Button)
| 19 01 // USAGE_MINIMUM (Button 1)
| 29 05 // USAGE_MAXIMUM (Button #)
| 15 00 // LOGICAL_MINIMUM (0)
| 25 01 // LOGICAL_MAXIMUM (1)
| 75 01 // REPORT_SIZE (1)
| 95 05 // REPORT_COUNT (Button #)
| 81 02 // INPUT (Data,Var,Abs)
| 75 03 // REPORT_SIZE (8 - Button #)
| 95 01 // REPORT_COUNT (1)
| 81 01 // INPUT (Cnst,Ary,Abs)
| 05 01 // USAGE_PAGE (Generic Desktop)
| 09 30 // USAGE (X)
| 09 31 // USAGE (Y)
| 16 01 F8 // LOGICAL_MINIMUM (-127)
| 26 FF 07 // LOGICAL_ MAXIMUM (127)
| 75 0C // REPORT_SIZE (8)
| 95 01 // REPORT_COUNT (3)
| 81 06 // INPUT (Data,Var,Rel)
| 09 38 // USAGE (Zwheel)
| 15 81 // LOGICAL_MINIMUM (-127)
| 25 7F // LOGICAL_ MAXIMUM (127)
| 75 08 // REPORT_SIZE (8)
| 95 01 // REPORT_COUNT (1)
| 81 06 // INPUT (Data,Var,Rel)
| 05 0C // USAGE_PAGE (Consumer)
| 0A 38 02 // USAGE (AC Pan)
| 81 06 // INPUT (Data,Var,Rel)
| C0 // END_COLLECTION
| C0 // END_COLLECTION

With without Tilt wheel and 12bit reporting: 05 01 09 02 A1 01 09 01
 A1 00 05 09 19 01 29 05
 15 00 25 01 75 01 95 05
 81 02 75 03 95 01 81 01
 05 01 09 30 09 31 16 01
 F8 26 FF 07 75 0C 95 02
 81 06 09 38 15 81 25 7F
 75 08 95 01 81 06 C0 C0

```
// HID Report
| 05 01 // USAGE_PAGE (Generic Desktop)
| 09 02 // USAGE (Mouse)
| A1 01 // COLLECTION (Application)
| 09 01 // USAGE (Pointer)
| A1 00 // COLLECTION (Physical)
| 05 09 // USAGE_PAGE (Button)
| 19 01 // USAGE_MINIMUM (Button 1)
| 29 05 // USAGE_MAXIMUM (Button #)
| 15 00 // LOGICAL_MINIMUM (0)
| 25 01 // LOGICAL_MAXIMUM (1)
| 75 01 // REPORT_SIZE (1)
| 95 05 // REPORT_COUNT (Button #)
| 81 02 // INPUT (Data,Var,Abs)
| 75 03 // REPORT_SIZE (8 - Button #)
| 95 01 // REPORT_COUNT (1)
| 81 01 // INPUT (Cnst,Ary,Abs)
| 05 01 // USAGE_PAGE (Generic Desktop)
| 09 30 // USAGE (X)
| 09 31 // USAGE (Y)
| 16 01 F8 // LOGICAL_MINIMUM (-127)
| 26 FF 07 // LOGICAL_MAXIMUM (127)
| 75 0C // REPORT_SIZE (8)
| 95 01 // REPORT_COUNT (3)
| 81 06 // INPUT (Data,Var,Rel)
| 09 38 // USAGE (Zwheel)
| 15 81 // LOGICAL_MINIMUM (-127)
| 25 7F // LOGICAL_MAXIMUM (127)
| 75 08 // REPORT_SIZE (8)
| 95 01 // REPORT_COUNT (1)
| 81 06 // INPUT (Data,Var,Rel)
| C0 // END_COLLECTION
| C0 // END_COLLECTION
```

Default: Accept

Addressed: Accept

Configured: Accept

Notes: The length of this report is needed in the HID descriptor.

Get_HID_Input	A1 01 00 01 00 00 nn 00 nn = 06 (with tilt wheel and 12 bit motion reporting) nn = 05 (without tilt wheel and 12 bit reporting)
Returns:	bb xx yy zz tw (tilt wheel) OR bb xx yy zz (Z-wheel) OR bb xx yy (if no Z-wheel present) bb = button byte xx = X motion byte yy = Y motion byte zz = Z motion byte tw = tilt wheel byte
Default:	Stall
Addressed:	Stall
Configured:	Accept
Notes:	If the device is configured, it will always respond with a report for this command, even if no motion or button changes have occurred. In this case, it would report 00 for motion and simply report the current button state. If a report is pending on endpt1, the data there will be reported and the report on endpt1 cleared. The mouse will only create new button/motion packets when it is in the Configured state See USB byte format end of this section for more detail

Get_Idle	A1 02 xx 00 00 00 01 00 xx = 00 All reports xx = 01 First report
Returns:	rr rr = rate in multiples of 4mS
Default:	Accept
Addressed:	Accept
Configured:	Accept
Notes:	The third byte of the command is to select the Report ID. There is only one for the mouse -- so, using 00 or 01 will work. See also Set_Idle.

Get_Vendor_Test	C0 01 00 00 xx 00 01 00 ii = ignore xx = address of register to read
Returns:	rr (depends on register read)
Default:	Accept
Addressed:	Accept
Configured:	Accept
Notes:	Address range (xx) is datasheet register range

Set_Address	00 05 xx 00 00 00 00 00 xx = new device address, from 00 to 7F
Default:	Accept
Addressed:	Accept
Configured:	Accept (undefined in USB Spec) Chip gets new address, but stays in "Configured" mode.
Notes:	If device is not configured, the device will be given the new address and put in the addressed state (or default if new address=00). If the device is already configured, the device will be given the new address state and remain configured.

Set_Configuration	00 09 xx 00 00 00 00 00 xx = 00 = not configured xx = 01 = configured
Default:	Accept (undefined in USB Spec)
Addressed:	Accept
Configured:	Accept
Notes:	Invalid config values will cause stall. Chip will stall invalid value in configured mode, and leave device in old (configured) mode.

Set_Interface	01 0B 00 00 00 00 00 00
Default:	Stall (undefined in USB Spec)
Addressed:	Stall
Configured:	Accept
Notes:	Mouse has only one valid interface (00) and alternate setting (00). Invalid values will cause stall. Chip retains previous (valid) interface state after executing this command in configured mode even if invalid values are given and command was stalled.

Set_Protocol	21 0B xx 00 00 00 00 00 xx = 00 = Boot protocol xx = 01 = Report protocol
Default:	Accept (Not in USB Spec)
Addressed:	Accept (Not in USB Spec)
Configured:	Accept
Notes:	3 byte data packets will be reported in boot mode. These bytes are button, XX data, and YY data. Tilt wheel botton 7,8 will not be reported

Set_Feature_Device	00 03 01 00 00 00 00 00
Default:	Accept (undefined in USB Spec)
Addressed:	Accept
Configured:	Accept
Notes:	This sets the remote wakeup bit.

Set_Feature_Endpt0	02 03 00 00 xx 00 00 00 02 03 00 00 00 00 00 00 02 03 00 00 80 00 00 00 xx = 00 = Endpt0 OUT xx = 80 = Endpt0 IN
Default:	Stall (undefined in USB Spec)
Addressed:	Stall
Configured:	Stall
Notes:	This (tries to) sets the halt bit. The chip always stalls the status stage for this command. The chip never reports the halt bit set for Endpt0 with the Get_Status_Endpt0 command, as any new SETUP command will clear Endpt0 stall.

Set_Feature_Endpt1	02 03 00 00 81 00 00 00
Default:	Stall (undefined in USB Spec)
Addressed:	Stall
Configured:	Accept
Notes:	Sets the halt bit for Endpt1.

Clear_Feature_Device	00 01 01 00 00 00 00 00
Default:	Accept (undefined in USB Spec)
Addressed:	Accept
Configured:	Accept
Notes:	This clears the remote wakeup bit.

Clear_Feature_Endpt0	02 01 00 00 xx 00 00 00 02 01 00 00 00 00 00 00 02 01 00 00 80 00 00 00 xx = 00 = Endpt0 OUT xx = 80 = Endpt0 IN
Default:	Accept (undefined in USB Spec)
Addressed:	Accept
Configured:	Accept
Notes:	The chip does NOT stall like it does for Set_Feature_Endpt0.

Clear_Feature_Endpt1	02 01 00 00 81 00 00 00
Default:	Stall (undefined in USB Spec)
Addressed:	Stall
Configured:	Accept
Notes:	See Set_Feature_Endpt1.

Set_Idle	21 0A xx rr 00 00 00 00 xx = 00 All reports xx = 01 First report rr = rate in multiples of 4mS
Default:	Accept
Addressed:	Accept
Configured:	Accept
Notes:	<p>The third byte of the command is to select the Report ID. There is only one for the mouse – so, using either 00 or 01 will work.</p> <p>The fourth byte of the command sets the rate in multiples of 4mS. The initial value for mice will be x00 which means “infinite” – that is packets only come out when there is a change in data.</p> <p>Data will only be allowed to come out when the device is configured. However, the chip will accept the command in Default or Addressed mode and use that value when the device is later configured.</p>

Set_Vendor_Test	40 01 00 00 xx yy 00 00 xx = address yy = data
Default:	Accept
Addressed:	Accept
Configured:	Accept
Notes:	Address range for “xx” should be 0x00 to 0x3F. Addresses above this are reserved for possible future use. See also Get_Vendor_Test.

Poll_Endpt1

Returns: bb xx yy zz tw
bb = button byte
xx = X motion byte
yy = Y motion byte
zz = Z motion byte (if Z-Wheel)
tw = tilt wheel byte

Default: Ignore request

Addressed: Ignore request

Configured: Accept (NAK if no data; Send packet if available)

Notes: See also Get_HID_Input. Endpt will only stall if halt bit is set by Set_Feature_Endpt1. Details of data packet are below

Endpt1 should be polled at least every 10 frames (mS). It is typically polled every 8 frames on Windows machines. For internal testing, Endpt1 can be continuously polled if desired.

The chip will not generate any report packets unless in the Configured state.

If Endpt1 is currently empty, any motion or button change will be loaded into the Endpt1 buffers. Once the Endpt1 buffers are full, any further motion events will get accumulated. When the Endpt1 buffers are later polled and emptied, the current accumulated X/Y/Z values will be loaded into the Endpt1 buffers. After transferring their data, the accumulation registers are reset so they are ready to start accumulating new motion events.

Button information is handled a bit differently. If the Endpt1 buffers are empty, and a button change event occurs, the new button state is put into the Endpt1 buffers. At the same time, the button state that is put in Endpt1 is copied for later use. While Endpt1 is full, changes in button state are essentially ignored. When Endpt1 is emptied, if the current button state is different than that which was last loaded into Endpt1, then the new state will be loaded and a new copy saved. Basically, the button state that is loaded into Endpt1 is always the current button state at that point in time. It should also be noted that there is hardware on the chip to help de-bounce the buttons.

Special note on wLength: The wLength parameter in commands specifies the maximum number of bytes a device should send back. The commands listed below are not able to handle a wLength of 0 correctly.

Get_Status_Device
Get_Status_Interface
Get_Status_Endpt0
Get_Status_Endpt1
Get_Configuration
Get_Interface

This chip will send one byte of data rather than none when wLength=0 is requested for the above commands.

USB Data Packet Format of mouse with tilt wheel

Bit	7	6	5	4	3	2	1	0
Byte 1	0	0	0	0	0	B3(MB)	B2(RB)	B1(LB)
Byte 2	X7	X6	X5	X4	X3	X2	X1	X0
Byte 3	Y3	Y2	Y1	Y0	X11	X10	X9	X8
Byte 4	Y11	Y10	Y9	Y8	Y7	Y6	Y5	Y4
Byte 5	Z7	Z6	Z5	Z4	Z3	Z2	Z1	Z0
Byte 6	TW7	TW6	TW5	TW4	TW3	TW2	TW1	TW0

USB Data Packet Format of mouse without tilt wheel

Bit	7	6	5	4	3	2	1	0
Byte 1	0	0	0	0	0	B3(MB)	B2(RB)	B1(LB)
Byte 2	X7	X6	X5	X4	X3	X2	X1	X0
Byte 3	Y3	Y2	Y1	Y0	X11	X10	X9	X8
Byte 4	Y11	Y10	Y9	Y8	Y7	Y6	Y5	Y4
Byte 5	Z7	Z6	Z5	Z4	Z3	Z2	Z1	Z0
Byte 6	0	0	0	0	0	0	0	0

USB Data Packet Format of 5 button mouse

Bit	7	6	5	4	3	2	1	0
Byte 1	0	0	0	B5	B4	B3(MB)	B2(RB)	B1(LB)
Byte 2	X7	X6	X5	X4	X3	X2	X1	X0
Byte 3	Y3	Y2	Y1	Y0	X11	X10	X9	X8
Byte 4	Y11	Y10	Y9	Y8	Y7	Y6	Y5	Y4
Byte 5	Z7	Z6	Z5	Z4	Z3	Z2	Z1	Z0
Byte 6	0	0	0	0	0	0	0	0

Registers

The sensor can be programmed through registers, via the USB port, and configuration and motion data can be read from these registers. Certain registers must be

“enabled” after power up but before first read or write to that register. The registers will be “disabled” by VDD going low or sending a USB reset command.

Address	Register
0x00	Product_ID
0x01	Revision_ID
0x02	MouseStat
0x03	Delta_X_L
0x04	Delta_Y_L
0x05	Delta_XY_H
0x06	SQUAL
0x07	Shut_Hi

Address	Register
0x08	Shut_Low
0x09	Pix_Max
0x0a	Pix_Accum
0x0b	Pix_Min
0x0c	Pix_Grabber
0x0d	Dz
0x0e-3f	Reserved
0x40	InvRevID

Product_ID Address: 0x00
Access: Read Reset Value: 0x27

Bit	7	6	5	4	3	2	1	0
Field	PID ₇	PID ₆	PID ₅	PID ₄	PID ₃	PID ₂	PID ₁	PID ₀

Data Type: Eight bit number with the product identifier.

USAGE: The value in this register does not change; it can be used to verify that the sensor communications link is OK.

Revision_ID Address: 0x01
Access: Read Reset Value: 0x01

Bit	7	6	5	4	3	2	1	0
Field	RID ₇	RID ₆	RID ₅	RID ₄	RID ₃	RID ₂	RID ₁	RID ₀

Data Type: Eight bit number with current revision of the IC.

USAGE: This register contains the IC revision. It is subject to change when new IC versions are released.

MouseStat Address: 0x02
 Access: Read Reset Value: Undefined

Bit	7	6	5	4	3	2	1	0
Field	MOT	Reserved	Reserved	BUT ₅	BUT ₄	BUT ₃	BUT ₂	BUT ₁

Data Type: Bit field

USAGE: A "1" in the motion bit indicates that the USB endpoint has valid data. This register is included for test purposes only. For navigation use, use the USB HID defined commands. The button status bits reported are for the debounce signals.

Field Name	Description
MOT	For Internal test purposes only
Reserved	Reserved
BUT ₅	Reports the status of B5 0 = pin at logic 1 (Vdd3) 1 = pin at logic 0 (GND)
BUT ₄	Reports the status of B4 0 = pin at logic 1 (Vdd3) 1 = pin at logic 0 (GND)
BUT ₃	Reports the status of B3 0 = pin at logic 1 (Vdd3) 1 = pin at logic 0 (GND)
BUT ₂	Reports the status of B2 0 = pin at logic 1 (Vdd3) 1 = pin at logic 0 (GND)
BUT ₁	Reports the status of B1 0 = pin at logic 1 (Vdd3) 1 = pin at logic 0 (GND)

Delta_X_L Address: 0x03
Access: Read Reset Value: 0x00

Bit	7	6	5	4	3	2	1	0
Field	X ₇	X ₆	X ₅	X ₄	X ₃	X ₂	X ₁	X ₀

Data Type: Bit field

USAGE: The value in this register reflects the last USB delta X (lower 8 bits) data output or data queued for output. This register is included for test purposes only. For navigation use, use the HID defined commands. Data is 2's complement. Absolute value is determined by the currently set resolution.

Register 0x03 must be read before register 0x04 (Delta_Y_L) and 0x05 (Delta_XY_H)

Delta_Y_L Address: 0x04
Access: Read Reset Value: 0x00

Bit	7	6	5	4	3	2	1	0
Field	Y ₇	Y ₆	Y ₅	Y ₄	Y ₃	Y ₂	Y ₁	Y ₀

Data Type: Bit field

USAGE: The value in this register reflects the last USB delta Y (lower 8 bits) data output or data queued for output. This register is included for test purposes only. Register 0x03 should be read before register 0x04 (Delta_Y_L) and 0x05 (Delta_XY_H), else Delta_Y_L will return 0. For navigation use, use the HID defined commands. Data is 2's complement. Absolute value is determined by the currently set resolution.

Delta_XY_H Address: 0x05
Access: Read Reset Value: 0x00

Bit	7	6	5	4	3	2	1	0
Field	X ₁₁	X ₁₀	X ₉	X ₈	Y ₁₁	Y ₁₀	Y ₉	Y ₈

Data Type: Bit field

USAGE: The value in this register reflects the last USB delta X and Y (upper 4 bits) data output or data queued for output. This register is included for test purposes only. Register 0x03 should be read before register 0x04 (Delta_Y_L) and 0x05 (Delta_XY_H), else Delta_XY_H will return 0. For navigation use, use the HID defined commands. Data is 2's complement. Absolute value is determined by the currently set resolution.

SQUAL Address: 0x06
Access: Read Reset Value: 0x00

Bit	7	6	5	4	3	2	1	0
Field	SQ ₇	SQ ₆	SQ ₅	SQ ₄	SQ ₃	SQ ₂	SQ ₁	SQ ₀

Data Type: Eight bit number.

USAGE: SQUAL is a measure of the number of features visible by the sensor in the current frame. The maximum value is 128. Since small changes in the current frame can result in changes in SQUAL, slight variations in SQUAL on one surface is expected.

Shut_Hi Address: 0x07
Access: Read Reset Value: 0x00

Bit	7	6	5	4	3	2	1	0
Field	S ₁₅	S ₁₄	S ₁₃	S ₁₂	S ₁₁	S ₁₀	S ₁₉	S ₁₈

Data Type: Eight bit number.

USAGE: The combination of Shut_Hi and Shut_Low is a 16-bit number. This is the number of clocks the shutter was open for the last image taken. The units are in main clocks ticks (nominally 24MHz). To avoid split read issues, read Shut_Hi first.

Shut_Low Address: 0x08
Access: Read Reset Value: 0x64

Bit	7	6	5	4	3	2	1	0
Field	S ₇	S ₆	S ₅	S ₄	S ₃	S ₂	S ₁	S ₀

Data Type: Eight bit number.

USAGE: The combination of Shut_Hi and Shut_Low is a 16-bit number. This is the number of clocks the shutter was open for the last image taken. The units are in main clocks ticks (nominally 24MHz). To avoid split read issues, read Shut_Hi first (0x06).

Pix_Max Address: 0x09
Access: Read Reset Value: 0x00

Bit	7	6	5	4	3	2	1	0
Field	0	MX ₆	MX ₅	MX ₄	MX ₃	MX ₂	MX ₁	MX ₀

Data Type: Eight bit number.

USAGE: This is the maximum pixel value from the last image taken.

Pix_Accum Address: 0x0a
Access: Read Reset Value: 0x00

Bit	7	6	5	4	3	2	1	0
Field	AC ₇	AC ₆	AC ₅	AC ₄	AC ₃	AC ₂	AC ₁	AC ₀

Data Type: Eight bit number.

USAGE: This is the accumulated pixel value from the last image taken. For the 19x19 raw image only the 8 most interesting bits are reported ([15:8]). To get the true average pixel value, divide this register value by 1.41.

Pix_Min Address: 0x0b
Access: Read Reset Value: 0x7f

Bit	7	6	5	4	3	2	1	0
Field	0	MN ₆	MN ₅	MN ₄	MN ₃	MN ₂	MN ₁	MN ₀

Data Type: Eight bit number.

USAGE: This is the minimum pixel value from the last image taken.

Pix_Grab Address: 0x0c
Access: Read Reset Value: 0x00

Bit	7	6	5	4	3	2	1	0
Field	VALID	PG ₆	PG ₅	PG ₄	PG ₃	PG ₂	PG ₁	PG ₀

Data Type: Eight bit number.

USAGE: The pixel grabber captures 1 pixel per frame. If there is a valid pixel in the grabber when this is read, the MSB will be set, an internal counter will incremented to captured the next pixel and the grabber will be armed to capture the next pixel. It will take 361 reads to upload the completed image.

Any write to this register will reset and arm the grabber to grab pixel 0 on the next image. See pixel array numbering in Figure 19.

Pixel Address Map (Looking through the sensor at the surface)

0	19	38	57	76	95	114	133	152	171	190	209	228	247	266	285	304	323	342
1	20	39	58	77	96	115	134	153	172	191	210	229	248	267	286	305	324	343
2	21	40	59	78	97	116	135	154	173	192	211	230	249	268	287	306	325	344
3	22	41	60	79	98	117	136	155	174	193	212	231	250	269	288	307	326	345
4	23	42	61	80	99	118	137	156	175	194	213	232	251	270	289	308	327	346
5	24	43	62	81	100	119	138	157	176	195	214	233	252	271	290	309	328	347
6	25	44	63	82	101	120	139	158	177	196	215	234	253	272	291	310	329	348
7	26	45	64	83	102	121	140	159	178	197	216	235	254	273	292	311	330	349
8	27	46	65	84	103	122	141	160	179	198	217	236	255	274	293	312	331	350
9	28	47	66	85	104	123	142	161	180	199	218	237	256	275	294	313	332	351
10	29	48	67	86	105	124	143	162	181	200	219	238	257	276	295	314	333	352
11	30	49	68	87	106	125	144	163	182	201	220	239	258	277	296	315	334	353
12	31	50	69	88	107	126	145	164	183	202	221	240	259	278	297	316	335	354
13	32	51	70	89	108	127	146	165	184	203	222	241	260	279	298	317	336	355
14	33	52	71	90	109	128	147	166	185	204	223	242	261	280	299	318	337	356
15	34	53	72	91	110	129	148	167	186	205	224	243	262	281	300	319	338	357
16	35	54	73	92	111	130	149	168	187	206	225	244	263	282	301	320	339	358
17	36	55	74	93	112	131	150	169	188	207	226	245	264	283	302	321	340	359
18	37	56	75	94	113	132	151	170	189	208	227	246	265	284	303	322	341	360

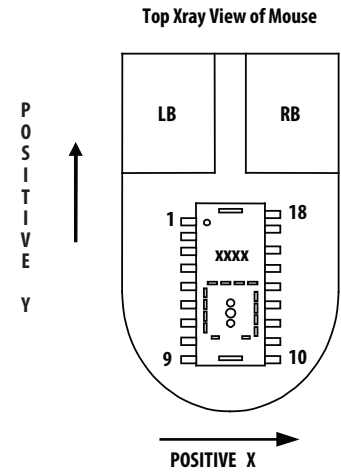

Figure 19. Pixel Map

The figure above shows the readout order of the array. Rows are read top to bottom and columns are from right to left.

Dz	Address: 0x0d							
Access: Read	Reset Value: 0x00							
Bit	7	6	5	4	3	2	1	0
Field	Z ₇	Z ₆	Z ₅	Z ₄	Z ₃	Z ₂	Z ₁	Z ₀

Data Type: Bit field

USAGE: If mouse is configured to contain a Z-wheel, this register contains the Z-wheel count. Range is from -127 to 127 decimal.

Reserved	Address: 0x0e – 0x3f
-----------------	----------------------

InvRevID
Access: Read

Address: 0x040
Reset Value: 0xfe

Bit	7	6	5	4	3	2	1	0
Field	RRID ₇	RRID ₆	RRID ₅	RRID ₄	RRID ₃	RRID ₂	RRID ₁	RRID ₀

Data Type: Eight bit number with current revision of the IC.

USAGE: Contains the inverse of the revision ID which is located in register 0x01.

IC Register state after Reset (power up)

Address	Register	Default Value	Meaning
0x00	Product_ID	0x27	Product ID = 27 (Fixed value)
0x01	Revision_ID	0x01	Revision of IC (Fixed value). (For each device design revision).
0x02	MouseStat	–	
0x03	Delta_X_L	0x00	
0x04	Delta_Y_L	0x00	
0x05	Delta_XY_H	0x00	
0x06	SQUAL	0x00	
0x07	Shut_Hi	0x00	
0x08	Shut_Low	0x64	
0x09	Pix_Max	0x00	
0x0a	Pix_Accum	0x00	
0x0b	Pix_Min	0x00	
0x0c	Pix_Grabber	0x00	
0x0d	Dz	0x00	
0x0e-3f	Reserved	–	
0x40	InverseRevision ID	0xFE	

For product information and a complete list of distributors, please go to our web site: www.avagotech.com

Avago, Avago Technologies, and the A logo are trademarks of Avago Technologies in the United States and other countries.
Data subject to change. Copyright © 2005-2009 Avago Technologies. All rights reserved.
AV02-1655EN - April 7, 2009

