

FEATURES

- 1 Watt Output Power
- 850 to 2200 MHz Operation
- Bias Control Input for Linearity Adjustment
- 12.5 dB Gain at 2160 MHz
- +43 dBm Output IP3 at 2160 MHz
- 4 dB Noise Figure at 880 MHz
- Single +5 V Supply
- -40 to +85 °C Operation

APPLICATIONS

- Driver Amplifiers for Multi-Carrier and Single Carrier Power Amplifiers in W-CDMA and PCS Base Stations
- ISM, Fixed Wireless and Satellite Systems



PRODUCT DESCRIPTION

The ADR3410 is a high performance, single-stage InGaP HBT amplifier designed for use in wireless infrastructure systems as a highly linear 1 Watt driver. Packaged in a surface mount 8 pin SOIC, the die is mounted to a heat slug, offering excellent thermal

dissipation and high reliability. The device may be biased through an external inductor directly to a +5 V supply, and uses an internal active bias circuit with a current adjust input for linearity control.

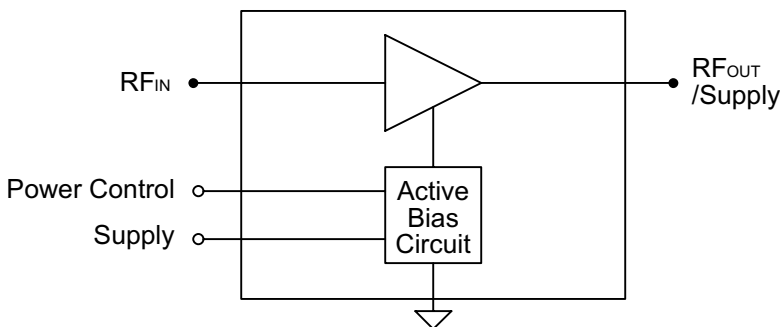

Figure 1: Block Diagram

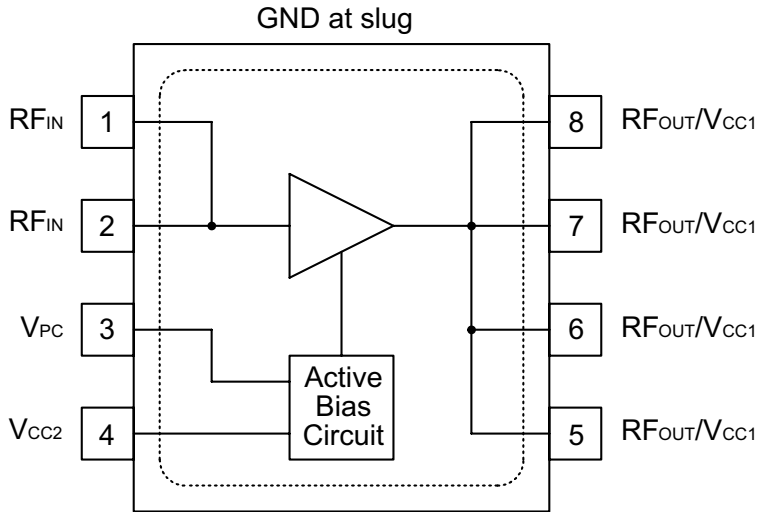

Figure 2: Pinout (X-ray Top View)

Table 1: Pin Description

PIN	NAME	DESCRIPTION
1, 2	RF _{IN}	RF Inputs.
3	V _{PC}	Power control input. This voltage input to the active bias circuit has a direct linear relationship to the amplifier current.
4	V _{CC2}	Supply voltage to active bias circuit.
5, 6, 7, 8	RF _{OUT} / V _{CC1}	RF Outputs, biased to supply voltage.
slug	GND	Ground

ELECTRICAL CHARACTERISTICS

Table 2: Absolute Minimum and Maximum Ratings

PARAMETER	MIN	MAX	UNIT	COMMENTS
Supply Voltage (V_{CC1}, V_{CC2})	0	+6	VDC	
Power Control Voltage (V_{PC})	0	+5	VDC	
RF Input Power	- -	+15 +20	dBm	at 880 MHz at 2160 MHz
Storage Temperature	-40	+150	°C	
Junction Temperature	-	+200	°C	

Stresses in excess of the absolute ratings may cause permanent damage. Functional operation is not implied under these conditions. Exposure to absolute ratings for extended periods of time may adversely affect reliability.

Table 3: Operating Ranges

PARAMETER	MIN	TYP	MAX	UNIT
Operating Frequency (f)	850	-	2200	MHz
Supply Voltage ($V_{CC1, CC2}$)	+3.6	+5.0	+6	VDC
Power Control Voltage (V_{PC})	+2.0	-	+4.5	VDC
Case Temperature	-40	-	+85	°C

The device may be operated safely over these conditions; however, parametric performance is guaranteed only over the conditions defined in the electrical specifications.

Table 4: Electrical Specifications
 (T_A = +25 °C, V_{CC} = +5 VDC, see Applications Circuits ⁽¹⁾)

PARAMETER	MIN	TYP	MAX	UNIT	COMMENTS
Gain: (S ₂₁)					
880 MHz	-	18.0	-	dB	V _{PC} = +3.8 V
2160 MHz	-	12.5	-		V _{PC} = +3.5 V
Output 1dB Compression (P1dB) ⁽²⁾					
880 MHz	-	+29	-	dBm	V _{PC} = +3.8 V
2160 MHz	-	+29	-		V _{PC} = +3.5 V
Output Third-Order Intercept (OIP3)					
880 MHz	-	+43	-	dBm	V _{PC} = +3.8 V
2160 MHz	-	+43	-		V _{PC} = +3.5 V
Noise Figure					
880 MHz	-	4	-	dB	V _{PC} = +3.8 V
Adjacent Channel Power Ratio ⁽³⁾	-	-75	-	dBc	f = 880 MHz, V _{PC} = +3.8 V
Thermal Resistance (θ _{JC})	-	30	-	°C/W	
Total Supply Current					
	-	280	-	mA	f = 880 MHz, V _{PC} = +3.8 V
	-	240	-		f = 2160 MHz, V _{PC} = +3.5 V
Power Control Current	-	60	220	µA	At V _{PC} pin

Notes:

- (1) Performance as measured on ANADIGICS test fixture, using the appropriate Application Circuit (see figures 3 & 4)
- (2) OIP3 is measured with two tones at 1 MHz spacing, +13 dBm output power per tone.
- (3) IS-95 modulation, +13 dBm channel power, ±885 KHz offset.

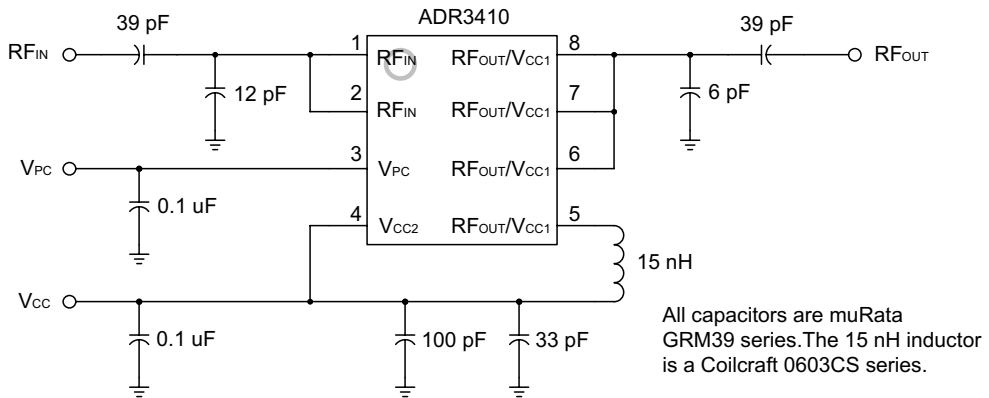

Figure 3: 869 - 894 MHz Application Circuit (50 Ω Terminations)

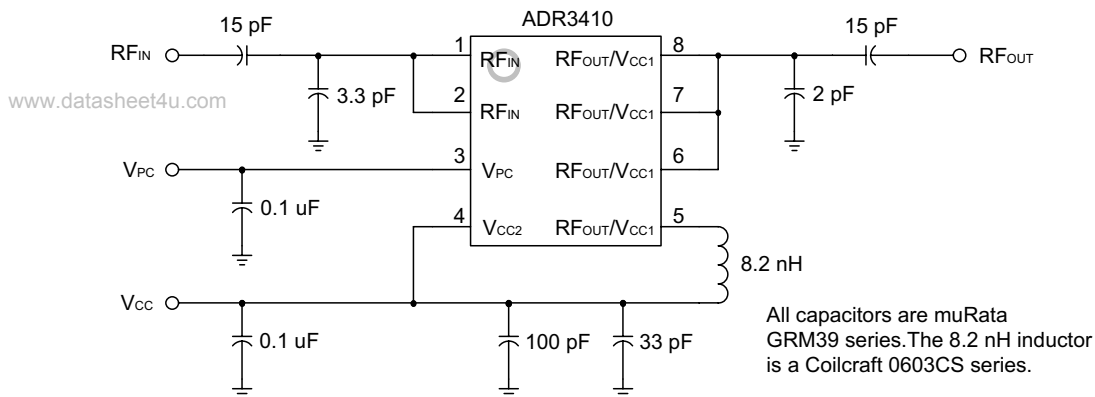

Figure 4: 2110 - 2170 MHz Application Circuit (50 Ω Terminations)

ADR3410

NOTES

www.datasheet4u.com

NOTES

www.datasheet4u.com

www.datasheet4u.com



ANADIGICS, Inc.

141 Mount Bethel Road

Warren, New Jersey 07059, U.S.A.

Tel: +1 (908) 668-5000

Fax: +1 (908) 668-5132

URL: <http://www.anadigics.com>

E-mail: Mktg@anadigics.com

IMPORTANT NOTICE

ANADIGICS, Inc. reserves the right to make changes to its products or to discontinue any product at any time without notice. The product specifications contained in Advanced Product Information sheets and Preliminary Data Sheets are subject to change prior to a product's formal introduction. Information in Data Sheets have been carefully checked and are assumed to be reliable; however, ANADIGICS assumes no responsibilities for inaccuracies. ANADIGICS strongly urges customers to verify that the information they are using is current before placing orders.

WARNING

ANADIGICS products are not intended for use in life support appliances, devices or systems. Use of an ANADIGICS product in any such application without written consent is prohibited.

www.DataSheet4U.com