

ADS4245-EP Dual-Channel, 14-Bit, 125MSPS Ultralow-Power ADC

1 Features

- Ultralow Power with Single 1.8V Supply, CMOS Output:
 - 277mW total power at 125MSPS
- High Dynamic Performance:
 - 88dBc SFDR at 170MHz
 - 71.4dBFS SNR at 170MHz
- Crosstalk: > 90dB at 185MHz
- Programmable Gain up to 6dB for SNR/SFDR Trade-off
- DC Offset Correction
- Output Interface Options:
 - 1.8V parallel CMOS interface
 - Double data rate (DDR) LVDS with programmable swing:
 - Standard swing: 350mV
 - Low swing: 200mV
- Supports Low Input Clock Amplitude Down to 200mV_{PP}
- Supports Defense, Aerospace, and Medical Applications
 - Controlled Baseline
 - One Assembly and Test Site
 - One Fabrication Site
 - Available in Military (–55°C to 125°C) Temperature Range
 - Extended Product Life Cycle
 - Extended Product-Change Notification
 - Product Traceability

2 Applications

- Wireless Communications Infrastructure
- Software Defined Radio
- Power Amplifier Linearization

3 Description

The ADS4245 is a low-speed variant of the ADS42xx ultralow-power family of dual-channel, 14-bit analog-to-digital converters (ADCs). Innovative design techniques are used to achieve high-dynamic performance, while consuming extremely low power with 1.8V supply. This topology makes the ADS4245 well-suited for multi-carrier, wide-bandwidth communications applications.

The ADS4245 has gain options that can be used to improve SFDR performance at lower full-scale input ranges. This device includes a dc offset correction loop that can be used to cancel the ADC offset. Both DDR (double data rate) LVDS and parallel CMOS digital output interfaces are available in a compact VQFN-64 PowerPAD™ package.

The device includes internal references while the traditional reference pins and associated decoupling capacitors have been eliminated. The ADS4245 is specified over the military temperature range (–55°C to 125°C).

Device Information

| ORDER NUMBER | PACKAGE | BODY SIZE |
|-----------------|-----------|-----------|
| ADS4245MRGC25EP | VQFN (64) | 9mm × 9mm |

Block Diagram

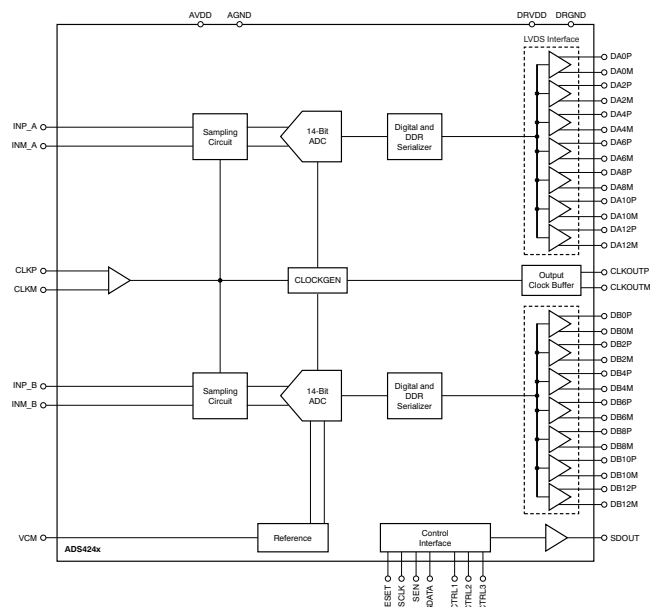

Table of Contents

| | | | |
|---|-----------|--|-----------|
| 1 Features | 1 | 7.3 Feature Description | 25 |
| 2 Applications | 1 | 7.4 Device Functional Modes | 25 |
| 3 Description | 1 | 7.5 Device Configuration | 32 |
| 4 Revision History | 2 | 7.6 Serial Register Map | 37 |
| 5 Pin Configuration and Functions | 3 | 7.7 Description Of Serial Registers | 38 |
| 6 Specifications | 7 | 8 Application and Implementation | 46 |
| 6.1 Absolute Maximum Ratings | 7 | 8.1 Application Information | 46 |
| 6.2 ESD Ratings | 7 | 8.2 Typical Applications | 47 |
| 6.3 Recommended Operating Conditions | 8 | 9 Power Supply Recommendations | 51 |
| 6.4 Thermal Information | 8 | 10 Layout | 51 |
| 6.5 Electrical Characteristics | 9 | 10.1 Layout Guidelines | 51 |
| 6.6 Electrical Characteristics: General | 10 | 10.2 Layout Example | 52 |
| 6.7 Digital Characteristics | 11 | 11 Device and Documentation Support | 53 |
| 6.8 Timing Characteristics: LVDS And CMOS Modes | 13 | 11.1 Device Support | 53 |
| 6.9 Typical Characteristics: | 17 | 11.2 Receiving Notification of Documentation Updates | 54 |
| 6.10 Typical Characteristics: General | 22 | 11.3 Community Resources | 55 |
| 6.11 Typical Characteristics: Contour | 23 | 11.4 Trademarks | 55 |
| 7 Detailed Description | 24 | 11.5 Electrostatic Discharge Caution | 55 |
| 7.1 Overview | 24 | 11.6 Glossary | 55 |
| 7.2 Functional Block Diagram | 24 | 12 Mechanical, Packaging, and Orderable Information | 55 |

4 Revision History

| Changes from Original (April 2014) to Revision A | Page |
|---|------|
| • Changed <i>Handling Rating To: ESD Ratings</i> | 7 |
| • Moved Storage temperature, T_{stg} From the <i>ESD Ratings</i> table to the <i>Absolute Maximum Ratings</i> table | 7 |
| • Added a MIN value of 1 MSPS to Low-speed mode enabled in the <i>Recommended Operating Conditions</i> | 8 |
| • Added NOTE to the <i>Application and Implementation</i> | 46 |

5 Pin Configuration and Functions

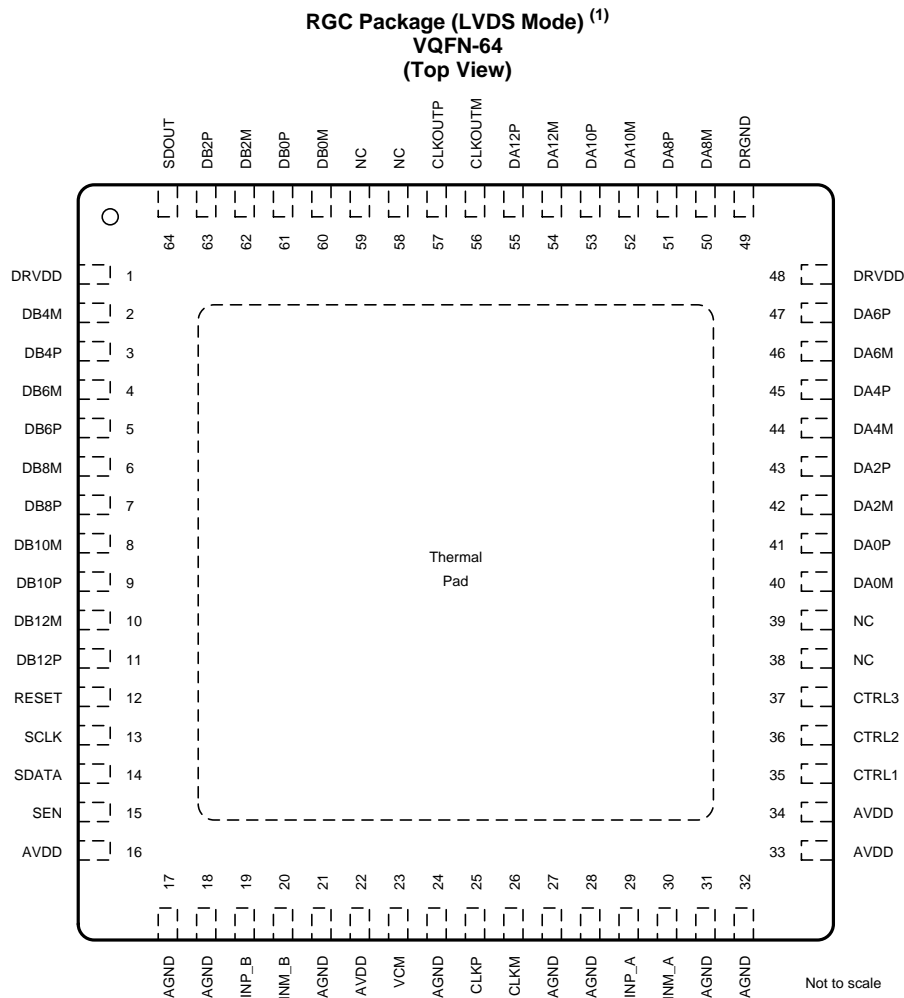

(1) The PowerPAD™ is connected to DRGND.

NOTE: NC = do not connect; must float.

Pin Functions: LVDS Mode

| NO. | NAME | # OF PINS | FUNCTION | DESCRIPTION |
|--------------------------------|-------|-----------|----------|---|
| 1, 48 | DRVDD | 2 | Input | Output buffer supply |
| 12 | RESET | 1 | Input | Serial interface RESET input. When using the serial interface mode, the internal registers must be initialized through a hardware RESET by applying a high pulse on this terminal or by using the software reset option; refer to the Serial Interface Configuration section. In parallel interface mode, the RESET terminal must be permanently tied high. SCLK and SEN are used as parallel control terminals in this mode. This terminal has an internal 150kΩ pull-down resistor. |
| 13 | SCLK | 1 | Input | This terminal functions as a serial interface clock input when RESET is low. It controls the low-speed mode selection when RESET is tied high; see Table 9 for detailed information. This terminal has an internal 150kΩ pull-down resistor. |
| 14 | SDATA | 1 | Input | Serial interface data input; this terminal has an internal 150kΩ pull-down resistor. |
| 15 | SEN | 1 | Input | This terminal functions as a serial interface enable input when RESET is low. It controls the output interface and data format selection when RESET is tied high; see Table 10 for detailed information. This terminal has an internal 150kΩ pull-up resistor to AVDD. |
| 16, 22, 33, 34 | AVDD | 4 | Input | Analog power supply |
| 17, 18, 21, 24, 27, 28, 31, 32 | AGND | 8 | Input | Analog ground |
| 19 | INP_B | 1 | Input | Differential analog positive input, channel B |

Pin Functions: LVDS Mode (continued)

| NO. | NAME | # OF PINS | FUNCTION | DESCRIPTION |
|----------------|---------|-----------|----------|---|
| 20 | INM_B | 1 | Input | Differential analog negative input, channel B |
| 23 | VCM | 1 | Output | This terminal outputs the common-mode voltage (0.95V) that can be used externally to bias the analog input terminals |
| 25 | CLKP | 1 | Input | Differential clock positive input |
| 26 | CLKM | 1 | Input | Differential clock negative input |
| 29 | INP_A | 1 | Input | Differential analog positive input, channel A |
| 30 | INM_A | 1 | Input | Differential analog negative input, channel A |
| 35 | CTRL1 | 1 | Input | Digital control input terminals. Together, they control the various power-down modes. |
| 36 | CTRL2 | 1 | Input | Digital control input terminals. Together, they control the various power-down modes. |
| 37 | CTRL3 | 1 | Input | Digital control input terminals. Together, they control the various power-down modes. |
| 49 | DRGND | 2 | Input | Output buffer ground |
| 56 | CLKOUTM | 1 | Output | Differential output clock, complement |
| 57 | CLKOUTP | 1 | Output | Differential output clock, true |
| 64 | SDOUT | 1 | Output | This terminal functions as a serial interface register readout when the READOUT bit is enabled. When READOUT = 0, this terminal is in high-impedance state. |
| 40 | DA0M | 2 | Output | Channel A differential output data pair, D0 and D1 multiplexed |
| 41 | DA0P | | | |
| 42 | DA2M | 2 | Output | Channel A differential output data D2 and D3 multiplexed |
| 43 | DA2P | | | |
| 44 | DA4M | 2 | Output | Channel A differential output data D4 and D5 multiplexed |
| 45 | DA4P | | | |
| 46 | DA6M | 2 | Output | Channel A differential output data D6 and D7 multiplexed |
| 47 | DA6P | | | |
| 50 | DA8M | 2 | Output | Channel A differential output data D8 and D9 multiplexed |
| 51 | DA8P | | | |
| 52 | DA10M | 2 | Output | Channel A differential output data D10 and D11 multiplexed |
| 53 | DA10P | | | |
| 54 | DA12M | 2 | Output | Channel A differential output data D12 and D13 multiplexed |
| 55 | DA12P | | | |
| 60 | DB0M | 2 | Output | Channel B differential output data pair, D0 and D1 multiplexed |
| 61 | DB0P | | | |
| 62 | DB2M | 2 | Output | Channel B differential output data D2 and D3 multiplexed |
| 63 | DB2P | | | |
| 2 | DB4M | 2 | Output | Channel B differential output data D4 and D5 multiplexed |
| 3 | DB4P | | | |
| 4 | DB6M | 2 | Output | Channel B differential output data D6 and D7 multiplexed |
| 5 | DB6P | | | |
| 6 | DB8M | 2 | Output | Channel B differential output data D8 and D9 multiplexed |
| 7 | DB8P | | | |
| 8 | DB10M | 2 | Output | Channel B differential output data D10 and D11 multiplexed |
| 9 | DB10P | | | |
| 10 | DB12M | 2 | Output | Channel B differential output data D12 and D13 multiplexed |
| 11 | DB12P | | | |
| 38, 39, 58, 59 | NC | 4 | — | Do not connect, must be floated |

RGC Package (CMOS Mode) ⁽¹⁾
VQFN-64
 (Top View)

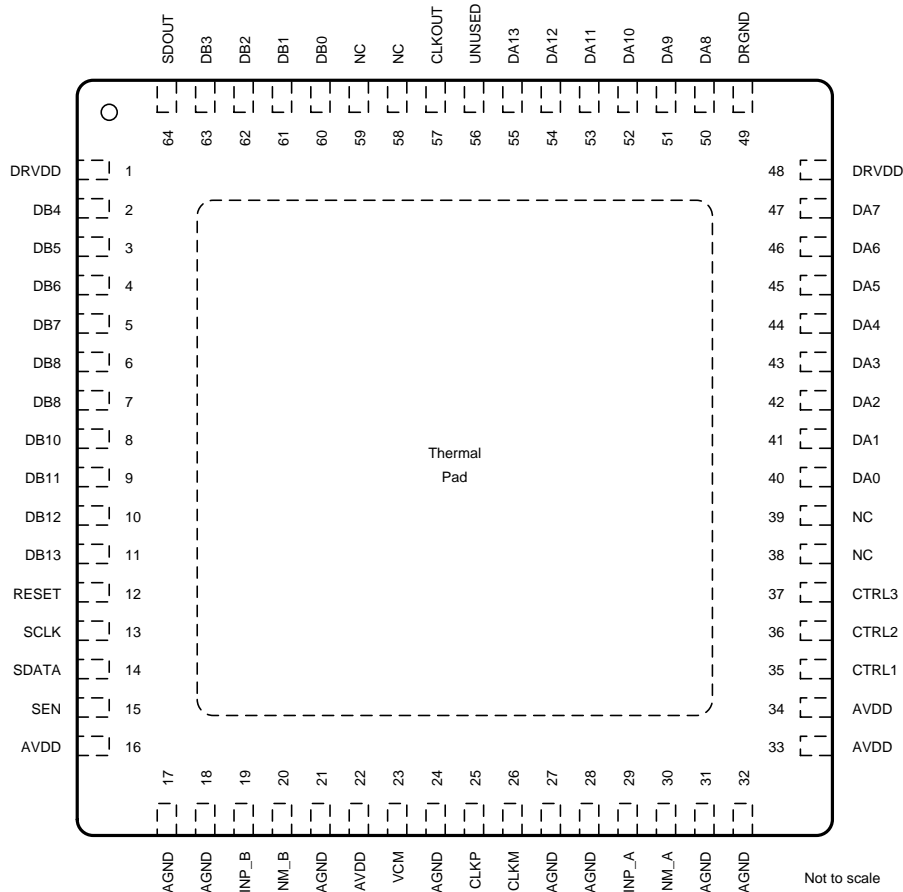

(1) The PowerPAD™ is connected to DRGND.

NOTE: NC = do not connect; must float.

Pin Functions: CMOS Mode

| NO. | NAME | # OF PINS | FUNCTION | DESCRIPTION |
|--------------------------------|-------|-----------|----------|--|
| 1, 48 | DRVDD | 2 | Input | Output buffer supply |
| 12 | RESET | 1 | Input | Serial interface RESET input. When using the serial interface mode, the internal registers must be initialized through a hardware RESET by applying a high pulse on this terminal or by using the software reset option; refer to the Serial Interface Configuration section. In parallel interface mode, the RESET terminal must be permanently tied high. SDATA and SEN are used as parallel control terminals in this mode. This terminal has an internal 150kΩ pull-down resistor. |
| 13 | SCLK | 1 | Input | This terminal functions as a serial interface clock input when RESET is low. It controls the low-speed mode when RESET is tied high; see Table 9 for detailed information. This terminal has an internal 150kΩ pull-down resistor. |
| 14 | SDATA | 1 | Input | Serial interface data input; this terminal has an internal 150kΩ pull-down resistor. |
| 15 | SEN | 1 | Input | This terminal functions as a serial interface enable input when RESET is low. It controls the output interface and data format selection when RESET is tied high; see Table 10 for detailed information. This terminal has an internal 150kΩ pull-up resistor to AVDD. |
| 16, 22, 33, 34 | AVDD | 4 | Input | Analog power supply |
| 17, 18, 21, 24, 27, 28, 31, 32 | AGND | 8 | Input | Analog ground |
| 19 | INP_B | 1 | Input | Differential analog positive input, channel B |
| 20 | INM_B | 1 | Input | Differential analog negative input, channel B |

Pin Functions: CMOS Mode (continued)

| NO. | NAME | # OF PINS | FUNCTION | DESCRIPTION |
|----------------|--------|-----------|----------|---|
| 23 | VCM | 1 | Output | This terminal outputs the common-mode voltage (0.95V) that can be used externally to bias the analog input terminals |
| 25 | CLKP | 1 | Input | Differential clock positive input |
| 26 | CLKM | 1 | Input | Differential clock negative input |
| 29 | INP_A | 1 | Input | Differential analog positive input, channel A |
| 30 | INM_A | 1 | Input | Differential analog negative input, channel A |
| 35 | CTRL1 | 1 | Input | Digital control input terminals. Together, they control various power-down modes. |
| 36 | CTRL2 | 1 | Input | Digital control input terminals. Together, they control various power-down modes. |
| 37 | CTRL3 | 1 | Input | Digital control input terminals. Together, they control various power-down modes. |
| 49 | DRGND | 2 | Input | Output buffer ground |
| 56 | UNUSED | 1 | — | This terminal is not used in the CMOS interface |
| 57 | CLKOUT | 1 | Output | CMOS output clock |
| 64 | SDOUT | 1 | Output | This terminal functions as a serial interface register readout when the READOUT bit is enabled. When READOUT = 0, this terminal is in high-impedance state. |
| 40 | DA0 | 12 | Output | Channel A ADC output data bits, CMOS levels |
| 41 | DA1 | | | |
| 42 | DA2 | | | |
| 43 | DA3 | | | |
| 44 | DA4 | | | |
| 45 | DA5 | | | |
| 46 | DA6 | | | |
| 47 | DA7 | | | |
| 50 | DA8 | | | |
| 51 | DA9 | | | |
| 52 | DA10 | | | |
| 53 | DA11 | | | |
| 54 | DA12 | 2 | Output | Channel A ADC output data bits, CMOS levels |
| 55 | DA13 | | | |
| 60 | DB0 | 12 | Output | Channel B ADC output data bits, CMOS levels |
| 61 | DB1 | | | |
| 62 | DB2 | | | |
| 63 | DB3 | | | |
| 2 | DB4 | | | |
| 3 | DB5 | | | |
| 4 | DB6 | | | |
| 5 | DB7 | | | |
| 6 | DB8 | | | |
| 7 | DB8 | | | |
| 8 | DB10 | | | |
| 9 | DB11 | | | |
| 10 | DB12 | 2 | Output | Channel B ADC output data bits, CMOS levels |
| 11 | DB13 | | | |
| 38, 39, 58, 59 | NC | 1 | — | Do not connect, must be floated |

6 Specifications

6.1 Absolute Maximum Ratings⁽¹⁾

| | | MIN | MAX | UNIT |
|---|---|------|------------------------------|------|
| Supply voltage, AVDD | | -0.3 | 2.1 | V |
| Supply voltage, DRVDD | | -0.3 | 2.1 | V |
| Voltage between AGND and DRGND | | -0.3 | 0.3 | V |
| Voltage between AVDD to DRVDD (when AVDD leads DRVDD) | | -2.4 | 2.4 | V |
| Voltage between DRVDD to AVDD (when DRVDD leads AVDD) | | -2.4 | 2.4 | V |
| Voltage applied to input terminals | INP_A, INM_A, INP_B, INM_B | -0.3 | Minimum (1.9, AVDD + 0.3) | V |
| | CLKP, CLKM ⁽²⁾ | -0.3 | AVDD + 0.3 | V |
| | RESET, SCLK, SDATA, SEN, CTRL1, CTRL2, CTRL3 | -0.3 | 3.9 | V |
| Junction temperature, T _J | | -55 | +150 | °C |
| Storage temperature, T _{stg} | | -65 | +150 | °C |

- (1) Stresses above these ratings may cause permanent damage. Exposure to absolute maximum conditions for extended periods may degrade device reliability. These are stress ratings only, and functional operation of the device at these or any other conditions beyond those specified is not implied.
- (2) When AVDD is turned off, it is recommended to switch off the input clock (or ensure the voltage on CLKP, CLKM is less than |0.3V|). This configuration prevents the ESD protection diodes at the clock input terminals from turning on.

6.2 ESD Ratings

| | | VALUE | UNIT |
|---------------------------------|---------------------------------------|-------|------|
| V _{ESD} ⁽¹⁾ | Human body model (HBM) ⁽²⁾ | ±2000 | V |

- (1) Electrostatic discharge (ESD) to measure device sensitivity and immunity to damage caused by assembly line electrostatic discharges in to the device.
- (2) Level listed above is the passing level per ANSI, ESDA, and JEDEC JS-001. JEDEC document JEP155 states that 500-V HBM allows safe manufacturing with a standard ESD control process.

6.3 Recommended Operating Conditions

Over operating free-air temperature range, unless otherwise noted.

| PARAMETER | MIN | NOM | MAX | UNIT |
|---|-----------|-----|------|-----------------|
| SUPPLIES | | | | |
| Analog supply voltage, AVDD | 1.7 | 1.8 | 1.9 | V |
| Digital supply voltage, DRVDD | 1.7 | 1.8 | 1.9 | V |
| ANALOG INPUTS | | | | |
| Differential input voltage | 2 | | | V _{PP} |
| Input common-mode voltage | VCM ±0.05 | | | V |
| Maximum analog input frequency with 2V _{PP} input amplitude ⁽¹⁾ | 400 | | | MHz |
| Maximum analog input frequency with 1V _{PP} input amplitude ⁽¹⁾ | 600 | | | MHz |
| CLOCK INPUT | | | | |
| Input clock sample rate | | | | |
| Low-speed mode enabled ⁽²⁾ | 1 | | 80 | MSPS |
| Low-speed mode disabled ⁽²⁾ (by default after reset) | 80 | | 125 | MSPS |
| Input clock duty cycle | | | | |
| Low-speed mode disabled ⁽³⁾ | 35% | 50% | 65% | |
| Low-speed mode enabled ⁽³⁾ | 40% | 50% | 60% | |
| DIGITAL OUTPUTS | | | | |
| Maximum external load capacitance from each output terminal to DRGND, C _{LOAD} | 5 | | | pF |
| Differential load resistance between the LVDS output pairs (LVDS mode), R _{LOAD} | 100 | | | Ω |
| Operating junction temperature, T _J | -55 | | +125 | °C |

(1) See the [Theory of Operation](#) section in the Application Information.

(2) See the [Serial Interface Configuration](#) section for details on programming the low-speed mode.

(3) Ensured by design for temperature range -40°C to 85°C.

6.4 Thermal Information

| THERMAL METRIC ⁽¹⁾ | | ADS4245-EP | UNIT |
|-------------------------------|--|-------------|------|
| | | RGC | |
| | | 64 TERMINAL | |
| R _{θJA} | Junction-to-ambient thermal resistance | 23.9 | °C/W |
| R _{θJctop} | Junction-to-case (top) thermal resistance | 10.9 | |
| R _{θJB} | Junction-to-board thermal resistance | 4.3 | |
| ψ _{JT} | Junction-to-top characterization parameter | 0.1 | |
| ψ _{JB} | Junction-to-board characterization parameter | 4.4 | |
| R _{θJcbot} | Junction-to-case (bottom) thermal resistance | 0.6 | |

(1) For more information about traditional and new thermal metrics, see the *Semiconductor and IC Package Thermal Metrics* application report ([SPRA953](#)).

Table 1. High-Performance Modes⁽¹⁾⁽²⁾

| PARAMETER | DESCRIPTION |
|-----------------------|--|
| High-performance mode | Set the HIGH PERF MODE register bit to obtain best performance across sample clock and input signal frequencies. Register address = 03h, data = 03h |
| High-frequency mode | Set the HIGH FREQ MODE CH A and HIGH FREQ MODE CH B register bits for high input signal frequencies greater than 200MHz. Register address = 4Ah, data = 01h Register address = 58h, data = 01h |

(1) It is recommended to use these modes to obtain best performance.

(2) See the [Serial Interface Configuration](#) section for details on register programming.

6.5 Electrical Characteristics:

Typical values are at +25°C, AVDD = 1.8V, DRVDD = 1.8V, 50% clock duty cycle, –1dBFS differential analog input, LVDS interface, and 0dB gain (unless otherwise noted). Minimum and maximum values are across the recommended operating condition (unless otherwise noted), AVDD = 1.8V, and DRVDD = 1.8V.

| PARAMETER | TEST CONDITIONS | MIN | TYP | MAX | UNIT |
|---|---|--|------|------|-------------|
| Resolution | | | | 14 | Bits |
| Signal-to-noise ratio | SNR | $f_{IN} = 20\text{MHz}$ | 73.4 | | dBFS |
| | | $f_{IN} = 70\text{MHz}$ | 68 | 72.9 | dBFS |
| | | $f_{IN} = 100\text{MHz}$ | | 72.6 | dBFS |
| | | $f_{IN} = 170\text{MHz}$ | | 71.4 | dBFS |
| | | $f_{IN} = 300\text{MHz}$ | | 69.3 | dBFS |
| Signal-to-noise and distortion ratio | SINAD | $f_{IN} = 20\text{MHz}$ | 73.2 | | dBFS |
| | | $f_{IN} = 70\text{MHz}$ | 68 | 72.6 | dBFS |
| | | $f_{IN} = 100\text{MHz}$ | | 72.3 | dBFS |
| | | $f_{IN} = 170\text{MHz}$ | | 71.2 | dBFS |
| | | $f_{IN} = 300\text{MHz}$ | | 68.5 | dBFS |
| Spurious-free dynamic range | SFDR | $f_{IN} = 20\text{MHz}$ | | 88 | dBc |
| | | $f_{IN} = 70\text{MHz}$ | 71 | 86 | dBc |
| | | $f_{IN} = 100\text{MHz}$ | | 85 | dBc |
| | | $f_{IN} = 170\text{MHz}$ | | 88 | dBc |
| | | $f_{IN} = 300\text{MHz}$ | | 78 | dBc |
| Total harmonic distortion | THD | $f_{IN} = 20\text{MHz}$ | | 86 | dBc |
| | | $f_{IN} = 70\text{MHz}$ | 68 | 84 | dBc |
| | | $f_{IN} = 100\text{MHz}$ | | 83 | dBc |
| | | $f_{IN} = 170\text{MHz}$ | | 84 | dBc |
| | | $f_{IN} = 300\text{MHz}$ | | 75 | dBc |
| Second-harmonic distortion | HD2 | $f_{IN} = 20\text{MHz}$ | | 88 | dBc |
| | | $f_{IN} = 70\text{MHz}$ | 66.5 | 86 | dBc |
| | | $f_{IN} = 100\text{MHz}$ | | 85 | dBc |
| | | $f_{IN} = 170\text{MHz}$ | | 88 | dBc |
| | | $f_{IN} = 300\text{MHz}$ | | 78 | dBc |
| Third-harmonic distortion | HD3 | $f_{IN} = 20\text{MHz}$ | | 93 | dBc |
| | | $f_{IN} = 70\text{MHz}$ | 72.5 | 89 | dBc |
| | | $f_{IN} = 100\text{MHz}$ | | 89 | dBc |
| | | $f_{IN} = 170\text{MHz}$ | | 90 | dBc |
| | | $f_{IN} = 300\text{MHz}$ | | 81 | dBc |
| Worst spur (other than second and third harmonics) | | $f_{IN} = 20\text{MHz}$ | | 95 | dBc |
| | | $f_{IN} = 70\text{MHz}$ | 73 | 94 | dBc |
| | | $f_{IN} = 100\text{MHz}$ | | 93 | dBc |
| | | $f_{IN} = 170\text{MHz}$ | | 91 | dBc |
| | | $f_{IN} = 300\text{MHz}$ | | 89 | dBc |
| Two-tone intermodulation distortion | IMD | $f_1 = 46\text{MHz}$, $f_2 = 50\text{MHz}$, each tone at –7dBFS | | 96 | dBFS |
| | | $f_1 = 185\text{MHz}$, $f_2 = 190\text{MHz}$, each tone at –7dBFS | | 92 | dBFS |
| Crosstalk | 20-MHz full-scale signal on channel under observation; 170-MHz full-scale signal on other channel | | 95 | | dB |
| Input overload recovery | Recovery to within 1% (of full-scale) for 6dB overload with sine-wave input | | 1 | | Clock cycle |
| AC power-supply rejection ratio | PSRR For 100mV _{pp} signal on AVDD supply, up to 10MHz | | > 30 | | dB |
| Effective number of bits | ENOB $f_{IN} = 70\text{MHz}$ | | 11.5 | | LSBs |
| Differential nonlinearity | DNL $f_{IN} = 70\text{MHz}$ | –0.97 | ±0.5 | 1.9 | LSBs |
| Integrated nonlinearity | INL $f_{IN} = 70\text{MHz}$ | | ±2 | ±5 | LSBs |

6.6 Electrical Characteristics: General

Typical values are at +25°C, AVDD = 1.8V, DRVDD = 1.8V, 50% clock duty cycle, and –1dBFS differential analog input (unless otherwise noted). Minimum and maximum values are across the recommended operating condition (unless otherwise noted), AVDD = 1.8V, and DRVDD = 1.8V.

| PARAMETER | MIN | TYP | MAX | UNIT |
|--|--------------------|-------|-----|-----------------|
| ANALOG INPUTS | | | | |
| Differential input voltage range (0dB gain) | | 2 | | V _{PP} |
| Differential input resistance (at 200MHz) | | 0.75 | | kΩ |
| Differential input capacitance (at 200MHz) | | 3.7 | | pF |
| Analog input bandwidth (with 50Ω source impedance, and 50Ω termination) | | 550 | | MHz |
| Analog input common-mode current (per input terminal of each channel) | | 1.5 | | μA/MSPS |
| Common-mode output voltage | VCM | 0.95 | | V |
| VCM output current capability | | 4 | | mA |
| DC ACCURACY | | | | |
| Offset error | –25 | 2.5 | 25 | mV |
| Temperature coefficient of offset error | | 0.003 | | mV/°C |
| Gain error as a result of internal reference inaccuracy alone | E _{GREF} | –4 | 4 | %FS |
| Gain error of channel alone | E _{GCHAN} | ±0.1 | | %FS |
| Temperature coefficient of E _{GCHAN} | | 0.002 | | Δ%/°C |
| POWER SUPPLY | | | | |
| IAVDD Analog supply current | | 105 | 130 | mA |
| IDRVDD Output buffer supply current LVDS interface, 350mV swing with 100Ω external termination, f _{IN} = 2.5MHz | | 99 | 120 | mA |
| IDRVDD Output buffer supply current CMOS interface, no load capacitance ⁽¹⁾ f _{IN} = 2.5MHz | | 49 | | mA |
| Analog power | | 189 | | mW |
| Digital power LVDS interface, 350mV swing with 100Ω external termination, f _{IN} = 2.5MHz | | 179 | | mW |
| Digital power CMOS interface, no load capacitance ⁽¹⁾ f _{IN} = 2.5MHz | | 88 | | mW |
| Global power-down | | | 25 | mW |

(1) In CMOS mode, the DRVDD current scales with the sampling frequency, the load capacitance on output terminals, input frequency, and the supply voltage (see the [CMOS Interface Power Dissipation](#) section in the [Application Information](#)).

6.7 Digital Characteristics

At AVDD = 1.8V and DRVDD = 1.8V (unless otherwise noted). DC specifications refer to the condition where the digital outputs do not switch, but are permanently at a valid logic level '0' or '1'.

| PARAMETER | | TEST CONDITIONS | MIN | TYP | MAX | UNIT |
|--|----------------------------|--|-------------|-------|------|------|
| DIGITAL INPUTS (RESET, SCLK, SDATA, SEN, CTRL1, CTRL2, CTRL3)⁽¹⁾ | | | | | | |
| High-level input voltage | | All digital inputs support 1.8V and 3.3V CMOS logic levels | 1.3 | | | V |
| Low-level input voltage | | | 0.4 | | | V |
| High-level input current | SDATA, SCLK ⁽²⁾ | V _{HIGH} = 1.8V | 10 | | | μA |
| | SEN ⁽³⁾ | V _{HIGH} = 1.8V | 0 | | | μA |
| Low-level input current | SDATA, SCLK | V _{LOW} = 0V | 0 | | | μA |
| | SEN | V _{LOW} = 0V | 10 | | | μA |
| DIGITAL OUTPUTS, CMOS INTERFACE (DA[13:0], DB[13:0], CLKOUT, SDOUT) | | | | | | |
| High-level output voltage | | | DRVDD – 0.1 | DRVDD | | V |
| Low-level output voltage | | | | 0 | 0.1 | V |
| Output capacitance (internal to device) | | | | | | pF |
| DIGITAL OUTPUTS, LVDS INTERFACE | | | | | | |
| High-level output differential voltage | V _{ODH} | With an external 100Ω termination | 220 | 350 | 490 | mV |
| Low-level output differential voltage | V _{ODL} | With an external 100Ω termination | –490 | –350 | –220 | mV |
| Output common-mode voltage | V _{OCM} | | 0.9 | 1.05 | 1.25 | V |

- (1) SCLK, SDATA, and SEN function as digital input terminals in serial configuration mode.
- (2) SDATA, SCLK have internal 150kΩ pull-down resistor.
- (3) SEN has an internal 150kΩ pull-up resistor to AVDD. Because the pull-up is weak, SEN can also be driven by 1.8V or 3.3V CMOS buffers.

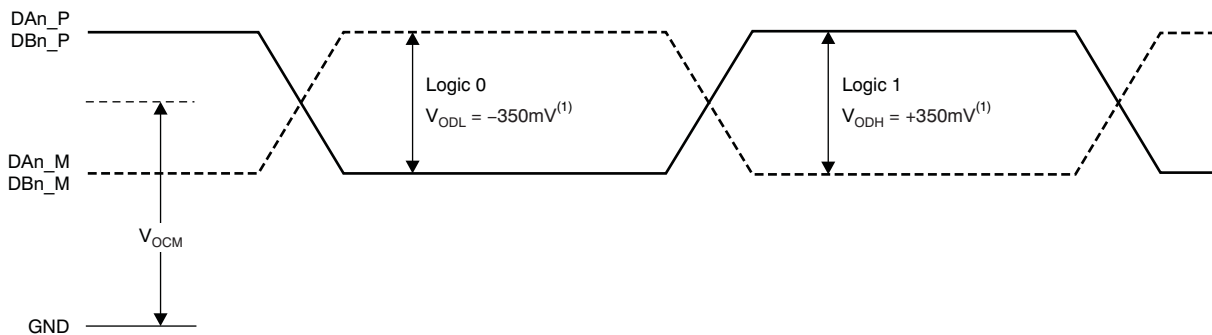

- (1) With external 100Ω termination.

Figure 1. LVDS Output Voltage Levels

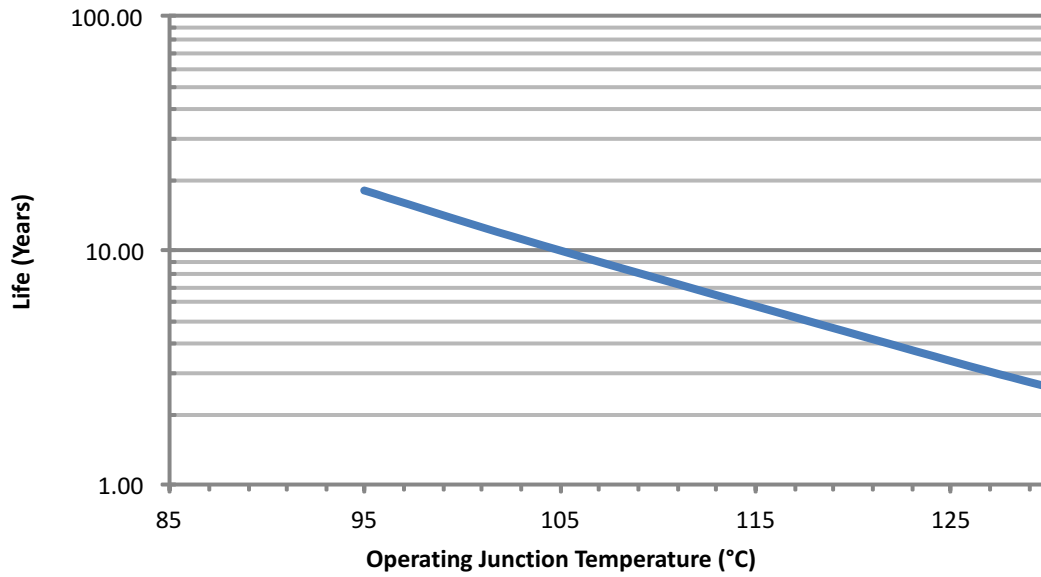

- (1) See datasheet for absolute maximum and minimum recommended operating conditions.
- (2) Silicon operating life design goal is 10 years at 105°C junction temperature (does not include package interconnect life).
- (3) Enhanced plastic product disclaimer applies.

Figure 2. ADS4245-EP Electromigration Fail Mode Chart

6.8 Timing Characteristics: LVDS And CMOS Modes⁽¹⁾

Typical values are at +25°C, AVDD = 1.8 V, DRVDD = 1.8V, sampling frequency = 160MSPS, sine wave input clock, 1.5V_{pp} clock amplitude, C_{LOAD} = 5pF⁽²⁾, and R_{LOAD} = 100Ω⁽³⁾, unless otherwise noted. Minimum and maximum values are across the full temperature range: T_{MIN} = –55°C to T_{MAX} = +125°C, AVDD = 1.8V, and DRVDD = 1.7V to 1.9V.

| PARAMETER | DESCRIPTION | MIN | TYP | MAX | UNIT | | |
|--|---|--|-----|------|--------------------|-----|----|
| t _A | Aperture delay | | 0.8 | | ns | | |
| | Aperture delay matching | Between the two channels of the same device | | ±70 | ps | | |
| | Variation of aperture delay | Between two devices at the same temperature and DRVDD supply | | ±150 | ps | | |
| t _J | Aperture jitter | | 140 | | f _S rms | | |
| | Wakeup time | Time to valid data after coming out of STANDBY mode | | 50 | 100 | μs | |
| | | Time to valid data after coming out of GLOBAL power-down mode | | 100 | 500 | μs | |
| ADC latency ⁽⁴⁾ | Default latency after reset | | 16 | | Clock cycles | | |
| | Digital functions enabled (EN DIGITAL = 1) | | 24 | | Clock cycles | | |
| DDR LVDS MODE⁽⁵⁾ | | | | | | | |
| t _{SU} | Data setup time | Data valid ⁽⁶⁾ to zero-crossing of CLKOUTP | | 1.5 | 2.0 | ns | |
| t _H | Data hold time | Zero-crossing of CLKOUTP to data becoming invalid ⁽⁶⁾ | | 0.35 | 0.6 | ns | |
| t _{PDI} | Clock propagation delay | Input clock rising edge cross-over to output clock rising edge cross-over | | 5.0 | 6.1 | 7.5 | ns |
| | LVDS bit clock duty cycle | Duty cycle of differential clock, (CLKOUTP-CLKOUTM) | | 49 | | % | |
| t _{RISE} , t _{FALL} | Data rise time, Data fall time | Rise time measured from –100mV to +100mV Fall time measured from +100mV to –100mV 1MSPS ≤ Sampling frequency ≤ 160MSPS | | 0.13 | | ns | |
| t _{CLKRISE} , t _{CLKFALL} | Output clock rise time, Output clock fall time | Rise time measured from –100mV to +100mV Fall time measured from +100mV to –100mV 1MSPS ≤ Sampling frequency ≤ 160MSPS | | 0.13 | | ns | |
| PARALLEL CMOS MODE | | | | | | | |
| t _{SU} | Data setup time | Data valid ⁽⁷⁾ to zero-crossing of CLKOUT | | 1.6 | 2.5 | ns | |
| t _H | Data hold time | Zero-crossing of CLKOUT to data becoming invalid ⁽⁷⁾ | | 2.3 | 2.7 | ns | |
| t _{PDI} | Clock propagation delay | Input clock rising edge cross-over to output clock rising edge cross-over | | 4.5 | 6.4 | 8.5 | ns |
| | Output clock duty cycle | Duty cycle of output clock, CLKOUT 1MSPS ≤ Sampling frequency ≤ 160MSPS | | 46 | | % | |
| t _{RISE} , t _{FALL} | Data rise time, Data fall time | Rise time measured from 20% to 80% of DRVDD Fall time measured from 80% to 20% of DRVDD 1MSPS ≤ Sampling frequency ≤ 160MSPS | | 1 | | ns | |
| t _{CLKRISE} , t _{CLKFALL} | Output clock rise time Output clock fall time | Rise time measured from 20% to 80% of DRVDD Fall time measured from 80% to 20% of DRVDD 1MSPS ≤ Sampling frequency ≤ 160MSPS | | 1 | | ns | |

(1) Timing parameters are ensured by design and characterization and not tested in production.

(2) C_{LOAD} is the effective external single-ended load capacitance between each output terminal and ground

(3) R_{LOAD} is the differential load resistance between the LVDS output pair.

(4) At higher frequencies, t_{PDI} is greater than one clock period and overall latency = ADC latency + 1.

(5) Measurements are done with a transmission line of 100Ω characteristic impedance between the device and the load. Setup and hold time specifications take into account the effect of jitter on the output data and clock.

(6) Data valid refers to a logic high of +100mV and a logic low of –100mV.

(7) Data valid refers to a logic high of 1.26V and a logic low of 0.54V

Table 2. LVDS Timings At Lower Sampling Frequencies

| SAMPLING FREQUENCY (MSPS) | SETUP TIME (ns) | | | HOLD TIME (ns) | | | t_{PDI} , CLOCK PROPAGATION DELAY (ns) | | |
|---------------------------|-----------------|-----|-----|----------------|-----|-----|--|-----|-----|
| | MIN | TYP | MAX | MIN | TYP | MAX | MIN | TYP | MAX |
| 65 | 5.9 | 6.6 | | 0.35 | 0.6 | | 5.0 | 6.1 | 7.5 |
| 80 | 4.5 | 5.2 | | 0.35 | 0.6 | | 5.0 | 6.1 | 7.5 |
| 125 | 2.3 | 2.9 | | 0.35 | 0.6 | | 5.0 | 6.1 | 7.5 |

Table 3. CMOS Timings At Lower Sampling Frequencies

| SAMPLING FREQUENCY (MSPS) | TIMINGS SPECIFIED WITH RESPECT TO CLKOUT | | | | | | | | |
|---------------------------|--|-----|-----|----------------|-----|-----|--|-----|-----|
| | SETUP TIME (ns) | | | HOLD TIME (ns) | | | t_{PDI} , CLOCK PROPAGATION DELAY (ns) | | |
| | MIN | TYP | MAX | MIN | TYP | MAX | MIN | TYP | MAX |
| 65 | 6.1 | 7.2 | | 6.7 | 7.1 | | 4.5 | 6.4 | 8.5 |
| 80 | 4.7 | 5.8 | | 5.3 | 5.8 | | 4.5 | 6.4 | 8.5 |
| 125 | 2.7 | 3.6 | | 3.1 | 3.6 | | 4.5 | 6.4 | 8.5 |

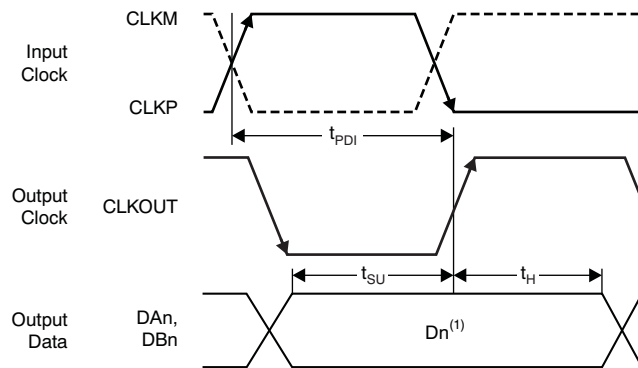

(1) Dn = bits D0, D1, D2, etc. of channels A and B.

Figure 3. CMOS Interface Timing Diagram

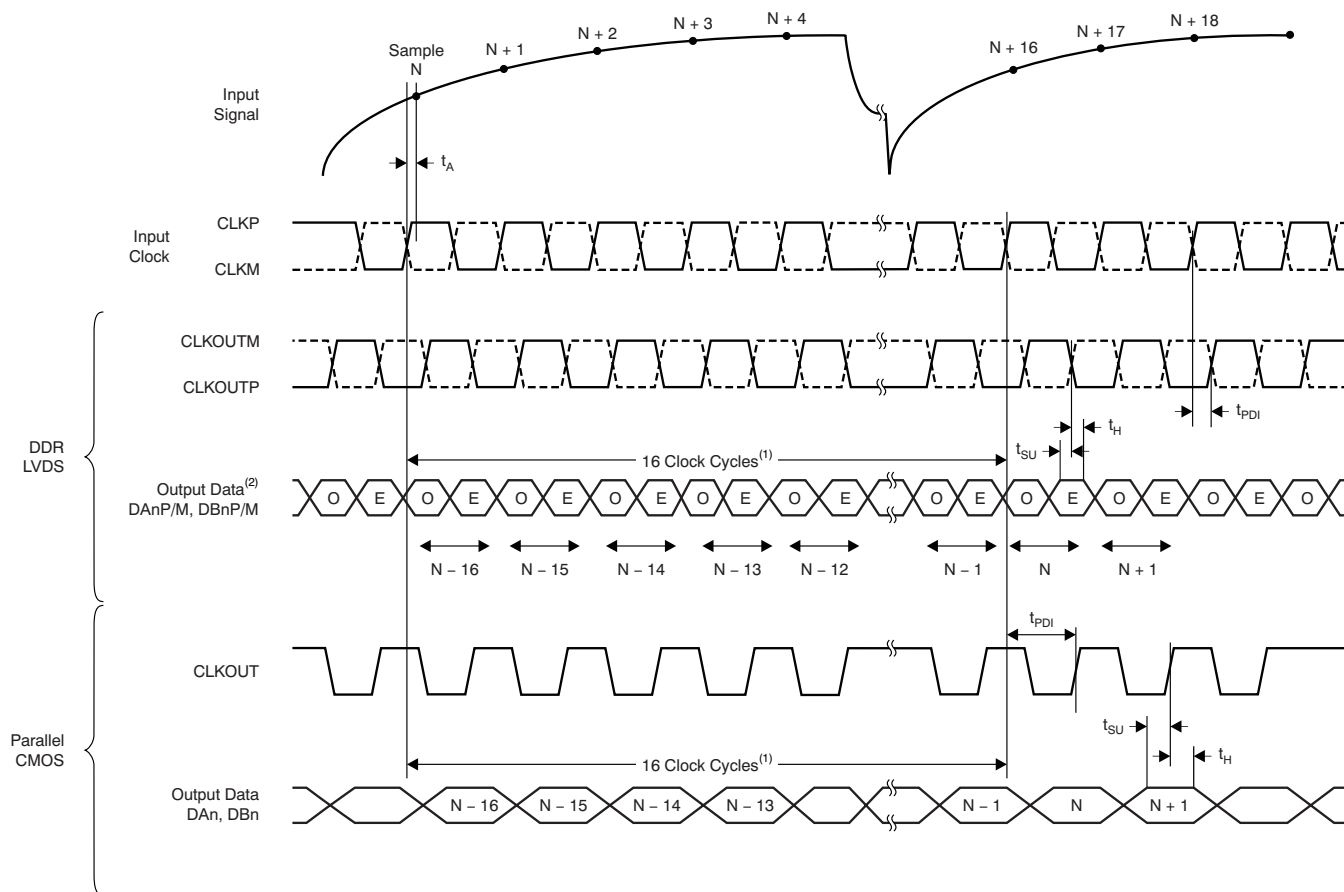

(1) ADC latency after reset. At higher sampling frequencies, t_{PDI} is greater than one clock cycle, which then makes the overall latency = ADC latency + 1.

(2) E = even bits (D0, D2, D4, etc.); O = odd bits (D1, D3, D5, etc.).

Figure 4. Latency Timing Diagram

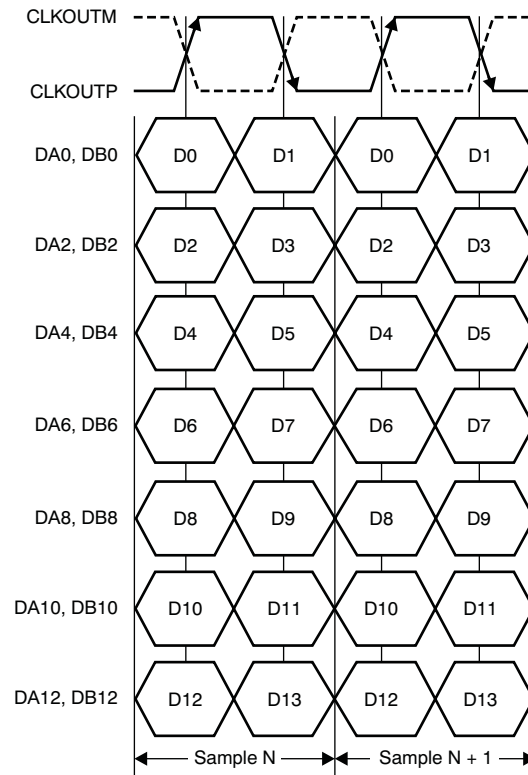
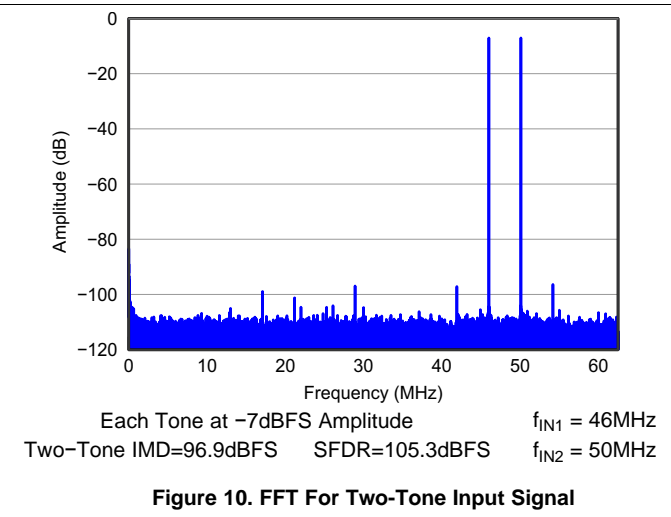
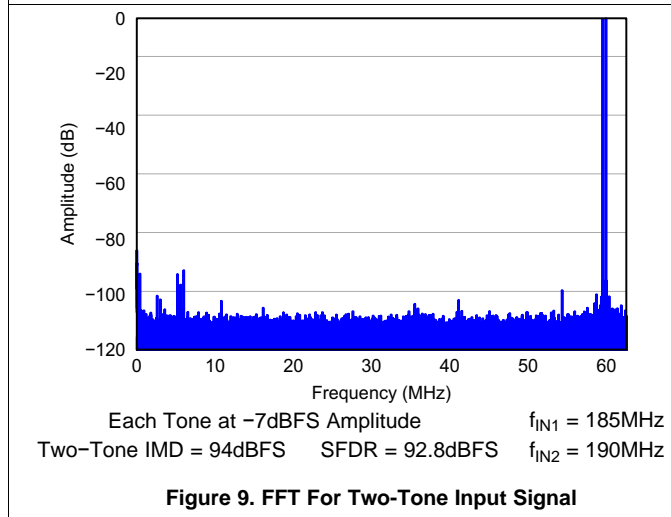
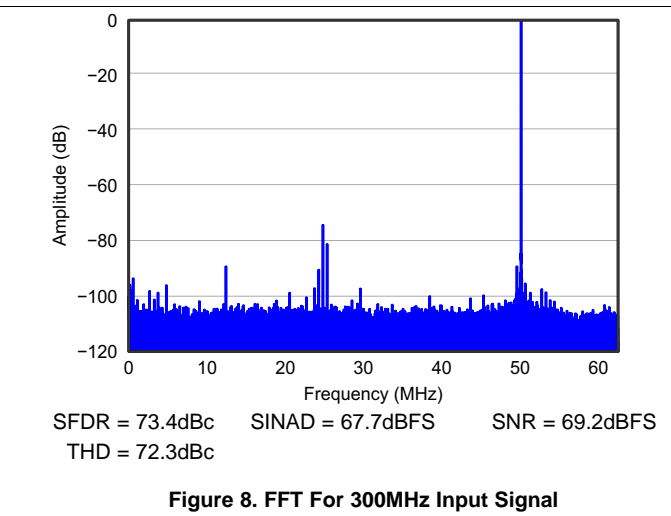
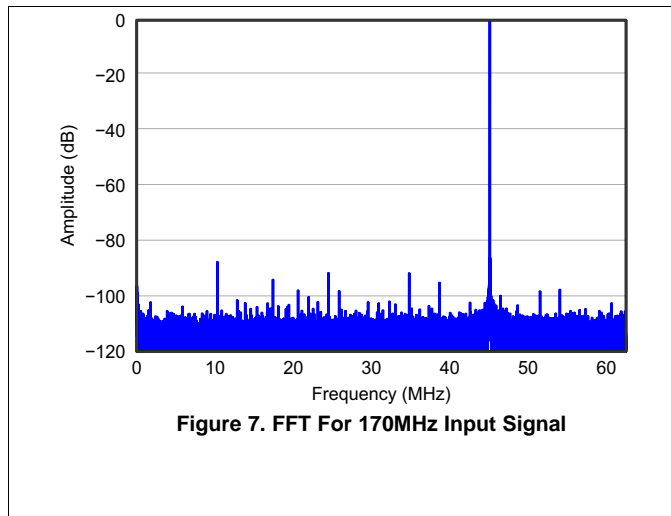
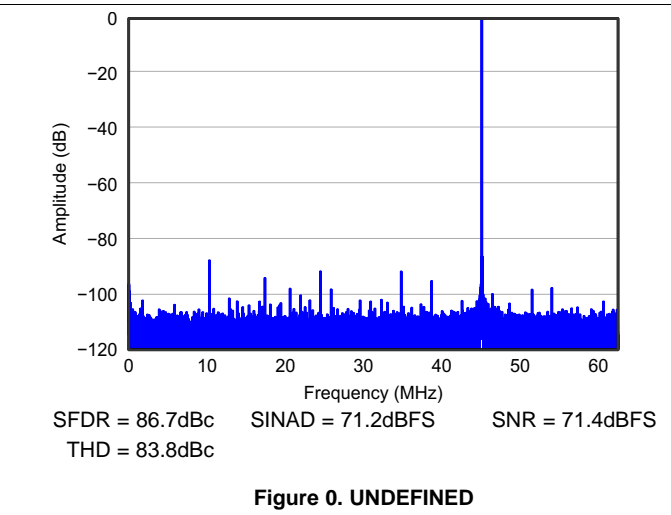
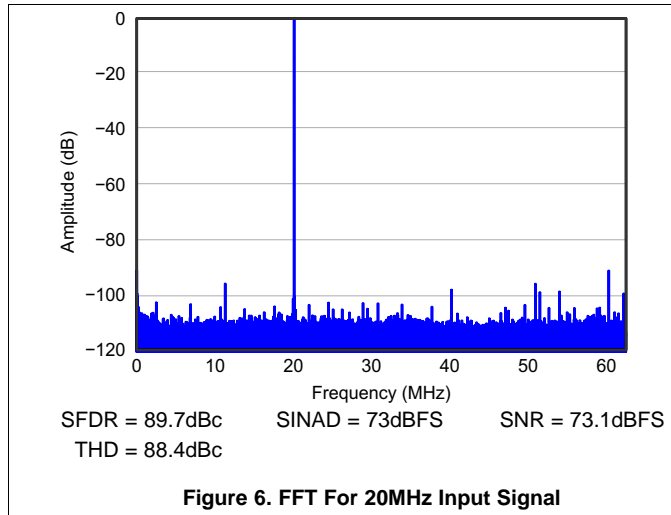

Figure 5. ADS4245 LVDS Interface Timing Diagram

6.9 Typical Characteristics:

At $T_A = +25^\circ\text{C}$, $AVDD = 1.8\text{V}$, $DRVDD = 1.8\text{V}$, maximum rated sampling frequency, sine wave input clock, 1.5V_{PP} differential clock amplitude, 50% clock duty cycle, -1dBFS differential analog input, High-Performance Mode disabled, 0dB gain, DDR LVDS output interface, and 32k point FFT, unless otherwise noted.



Typical Characteristics: (continued)

At $T_A = +25^\circ\text{C}$, $AVDD = 1.8\text{V}$, $DRVDD = 1.8\text{V}$, maximum rated sampling frequency, sine wave input clock, 1.5V_{PP} differential clock amplitude, 50% clock duty cycle, -1dBFS differential analog input, High-Performance Mode disabled, 0dB gain, DDR LVDS output interface, and 32k point FFT, unless otherwise noted.

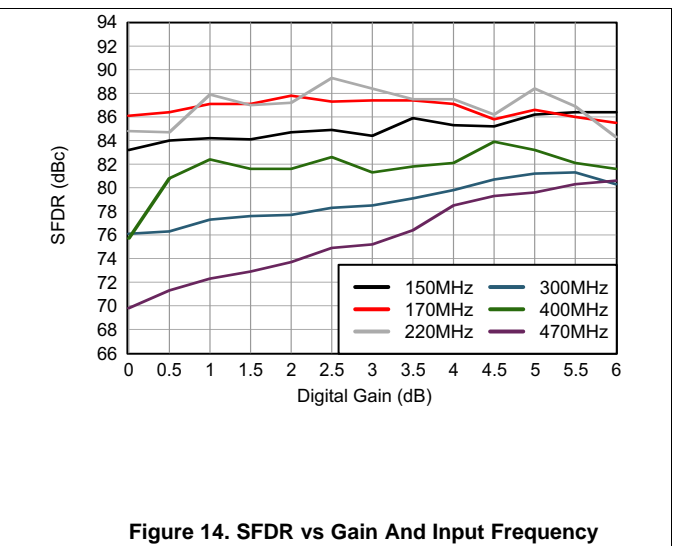
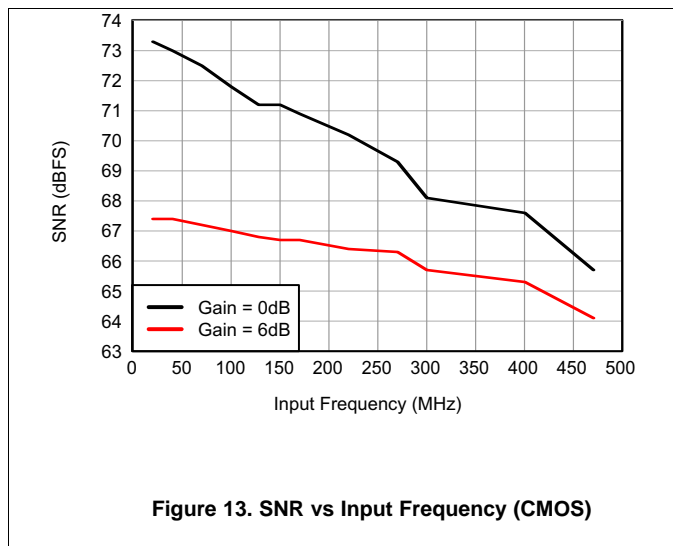
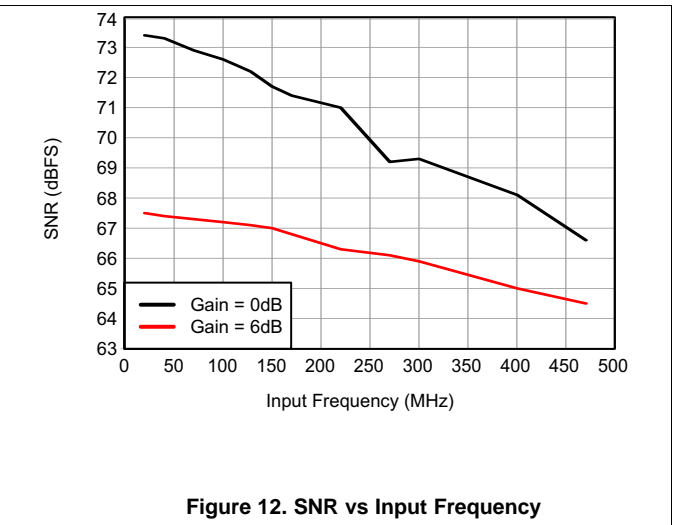
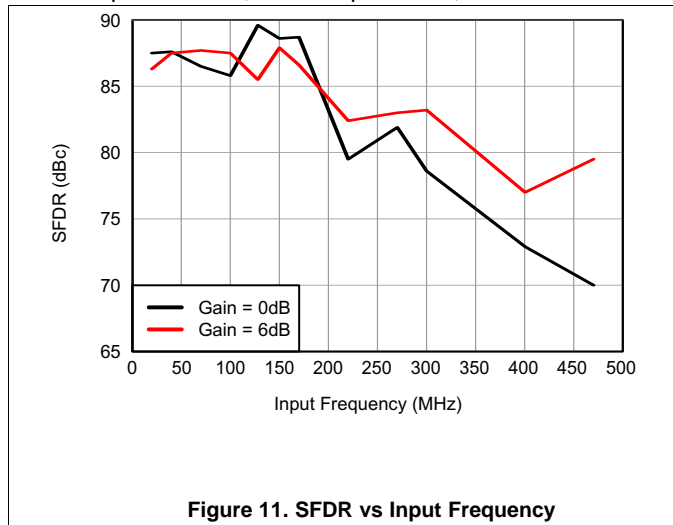

Typical Characteristics: (continued)

At $T_A = +25^\circ\text{C}$, $\text{AVDD} = 1.8\text{V}$, $\text{DRVDD} = 1.8\text{V}$, maximum rated sampling frequency, sine wave input clock, 1.5V_{PP} differential clock amplitude, 50% clock duty cycle, -1dBFS differential analog input, High-Performance Mode disabled, 0dB gain, DDR LVDS output interface, and 32k point FFT, unless otherwise noted.

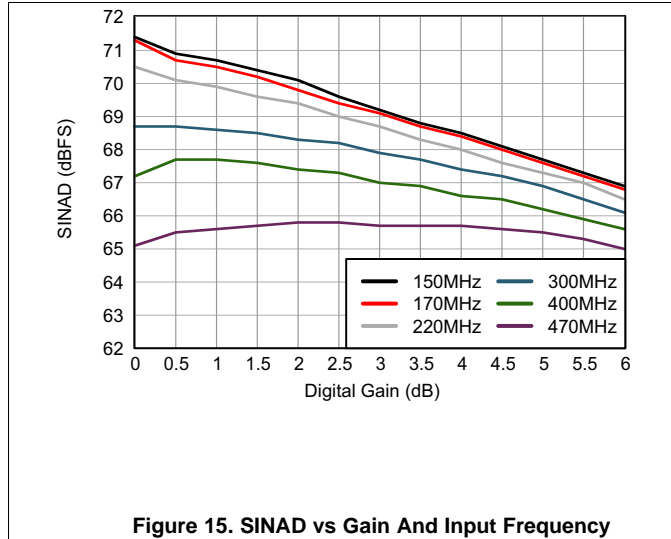

Figure 15. SINAD vs Gain And Input Frequency

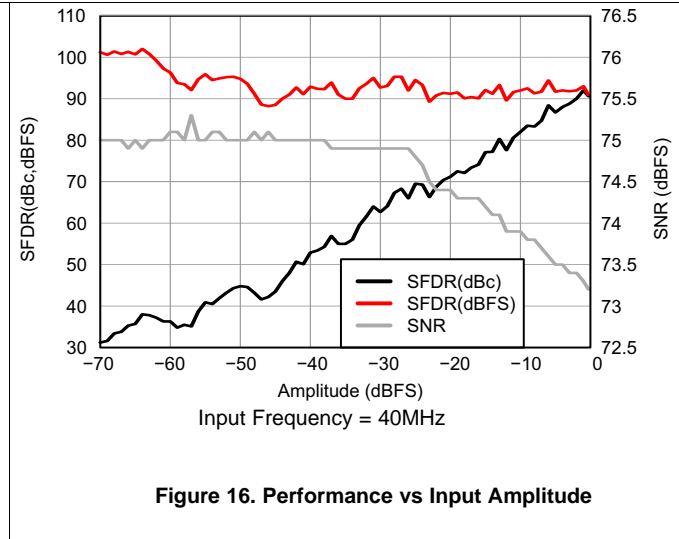

Figure 16. Performance vs Input Amplitude

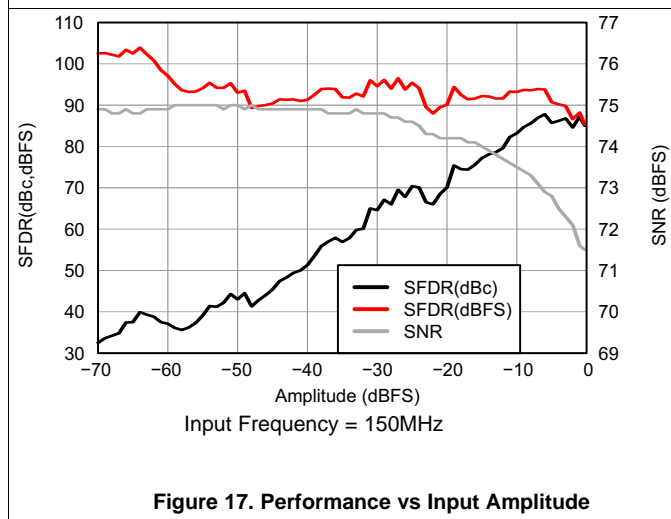

Figure 17. Performance vs Input Amplitude

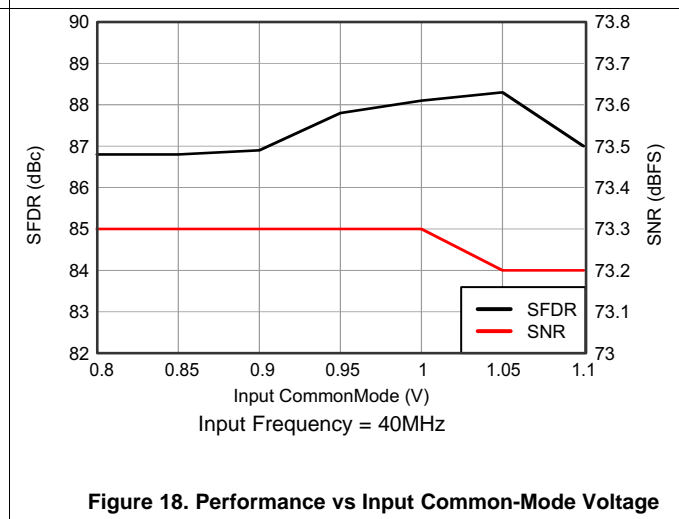

Figure 18. Performance vs Input Common-Mode Voltage

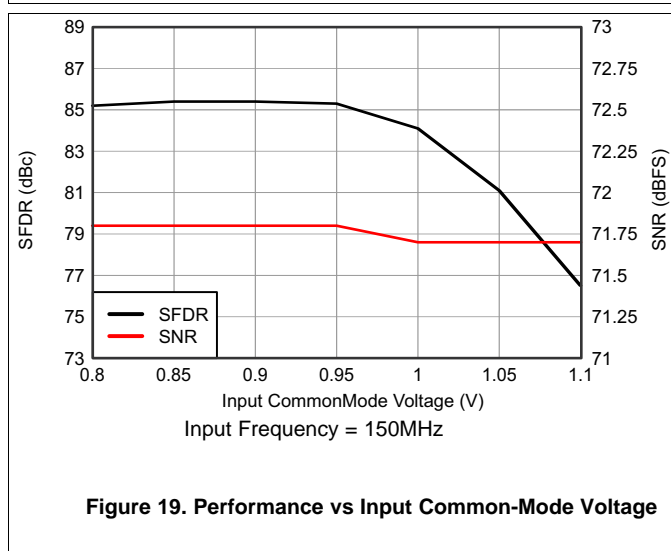

Figure 19. Performance vs Input Common-Mode Voltage

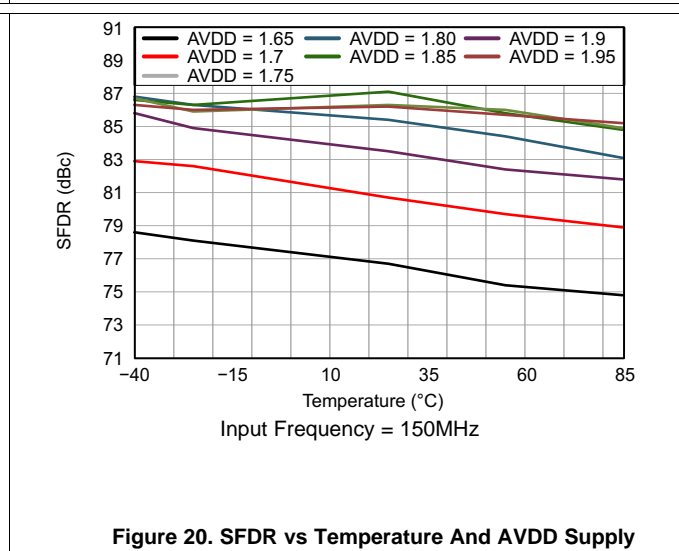

Figure 20. SFDR vs Temperature And AVDD Supply

Typical Characteristics: (continued)

At $T_A = +25^\circ\text{C}$, AVDD = 1.8V, DRVDD = 1.8V, maximum rated sampling frequency, sine wave input clock, 1.5V_{PP} differential clock amplitude, 50% clock duty cycle, -1dBFS differential analog input, High-Performance Mode disabled, 0dB gain, DDR LVDS output interface, and 32k point FFT, unless otherwise noted.

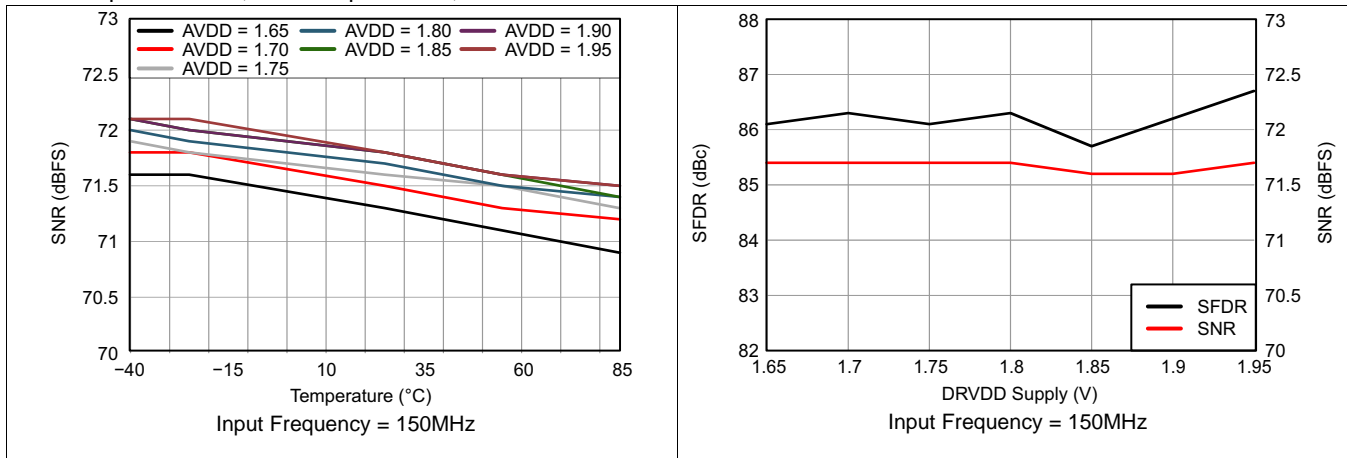

Figure 21. SNR vs Temperature And AVDD Supply

Figure 22. Performance vs DRVDD Supply Voltage

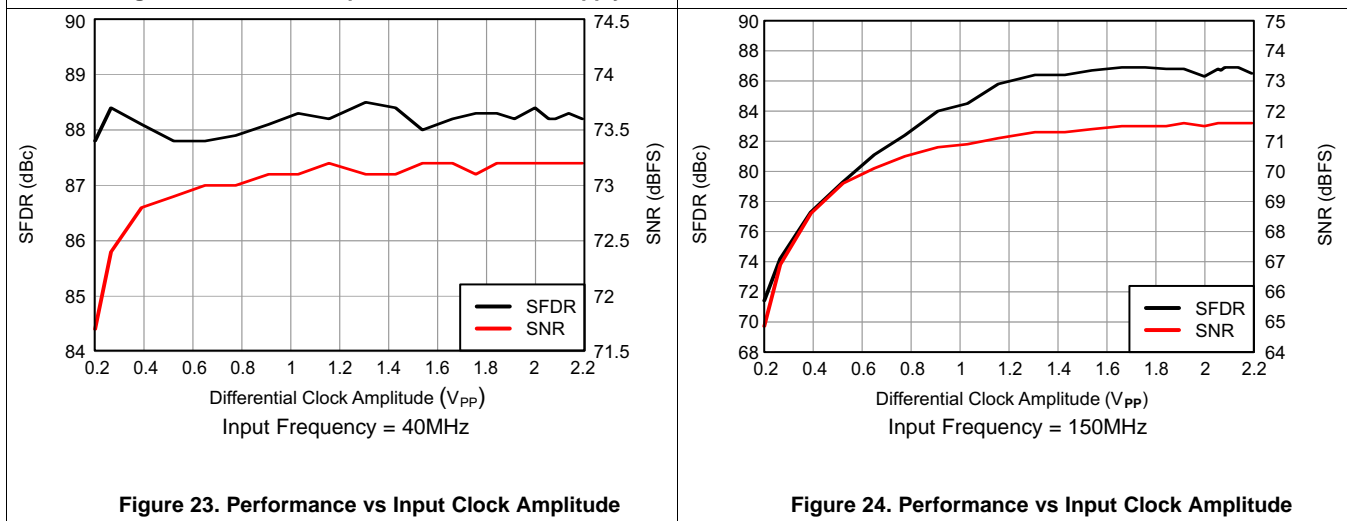

Figure 23. Performance vs Input Clock Amplitude

Figure 24. Performance vs Input Clock Amplitude

Typical Characteristics: (continued)

At $T_A = +25^\circ\text{C}$, $AVDD = 1.8\text{V}$, $DRVDD = 1.8\text{V}$, maximum rated sampling frequency, sine wave input clock, 1.5V_{PP} differential clock amplitude, 50% clock duty cycle, -1dBFS differential analog input, High-Performance Mode disabled, 0dB gain, DDR LVDS output interface, and 32k point FFT, unless otherwise noted.

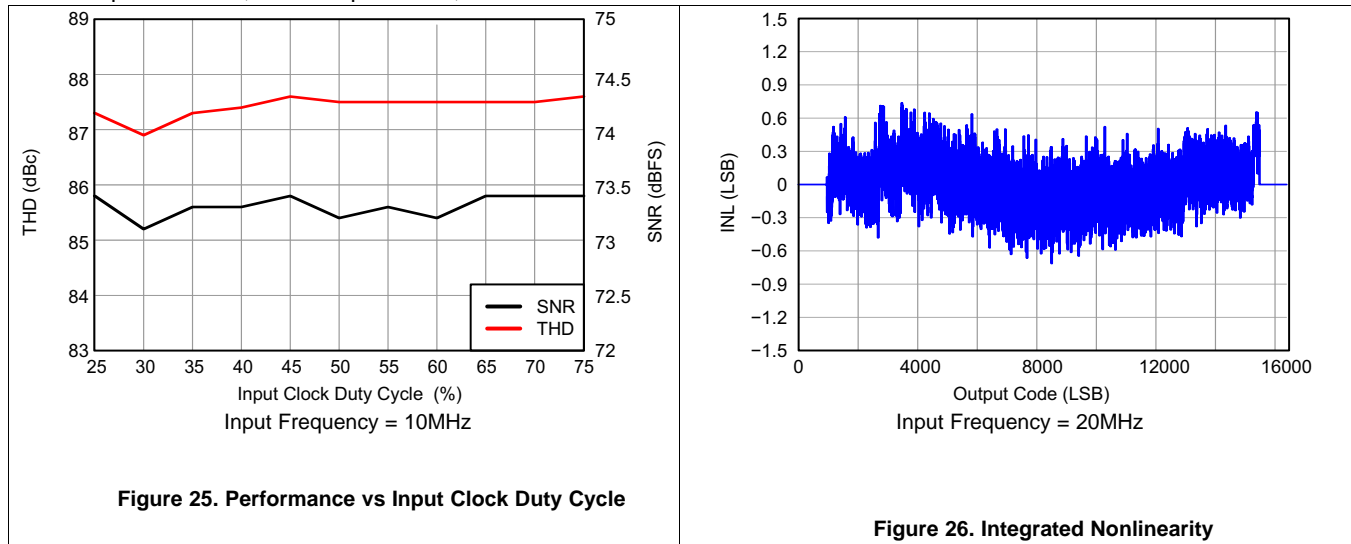

Figure 25. Performance vs Input Clock Duty Cycle

Figure 26. Integrated Nonlinearity

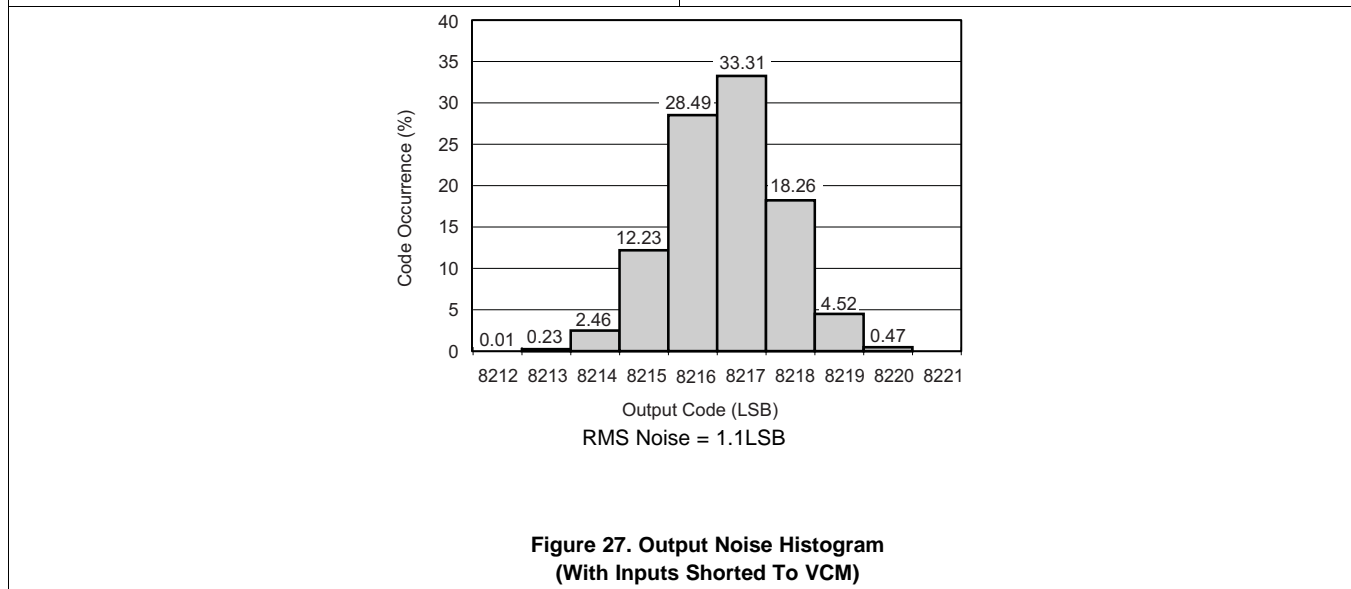
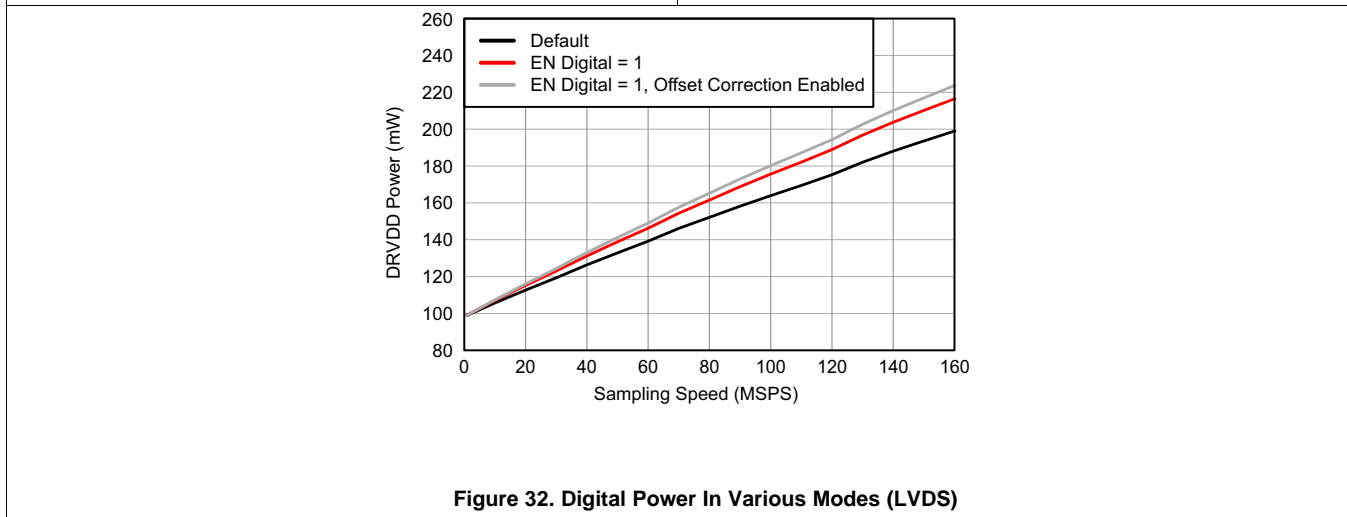
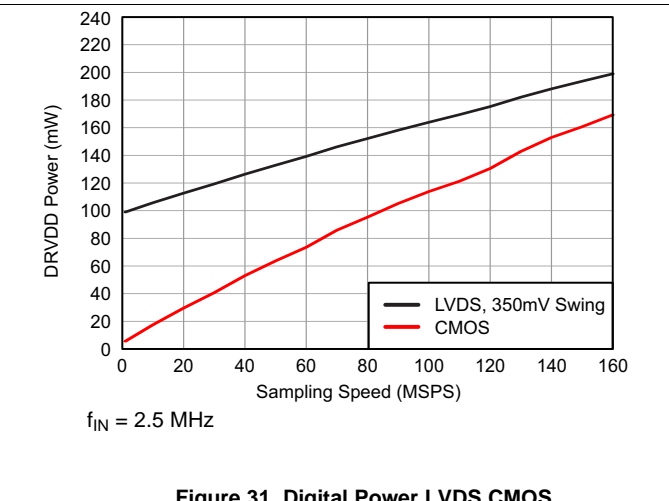
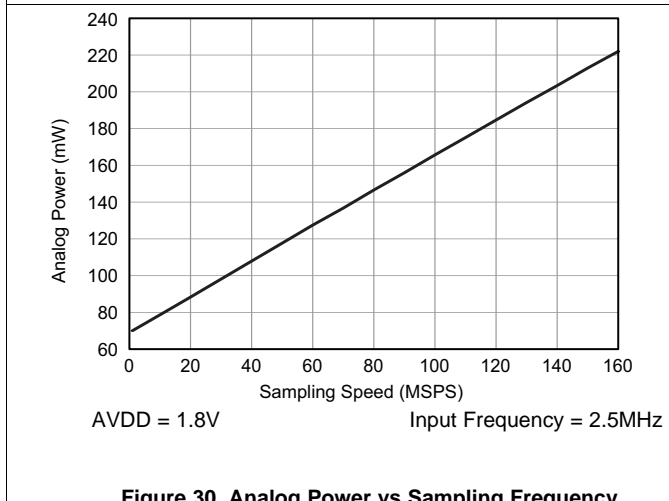
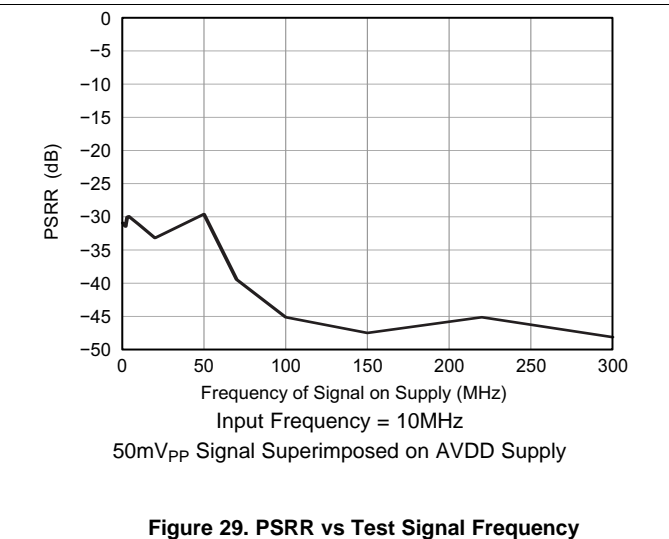
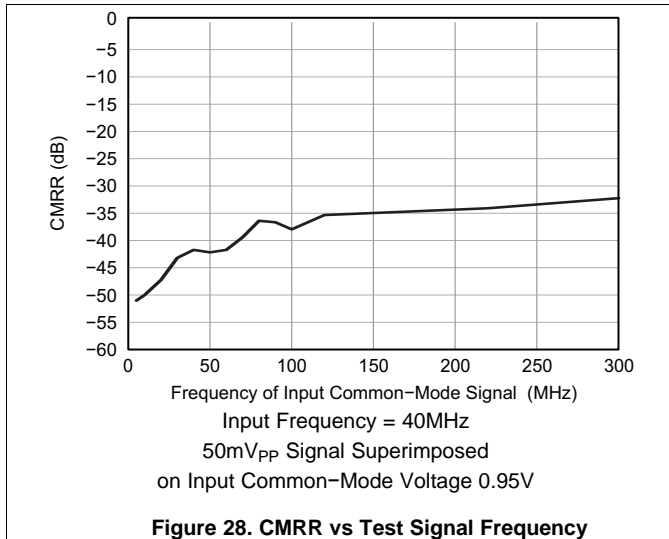

Figure 27. Output Noise Histogram (With Inputs Shorted To VCM)

6.10 Typical Characteristics: General

At $T_A = +25^\circ\text{C}$, $AVDD = 1.8\text{V}$, $DRVDD = 1.8\text{V}$, maximum rated sampling frequency, sine wave input clock, 1.5V_{PP} differential clock amplitude, 50% clock duty cycle, -1dBFS differential analog input, High-Performance Mode disabled, 0dB gain, DDR LVDS output interface, and 32k point FFT, unless otherwise noted.



6.11 Typical Characteristics: Contour

All graphs are at +25°C, AVDD = 1.8V, DRVDD = 1.8V, maximum rated sampling frequency, sine wave input clock. 1.5V_{pp} differential clock amplitude, 50% clock duty cycle, -1dBFS differential analog input, High-Performance Mode disabled, 0dB gain, DDR LVDS output interface, and 32k point FFT, unless otherwise noted.

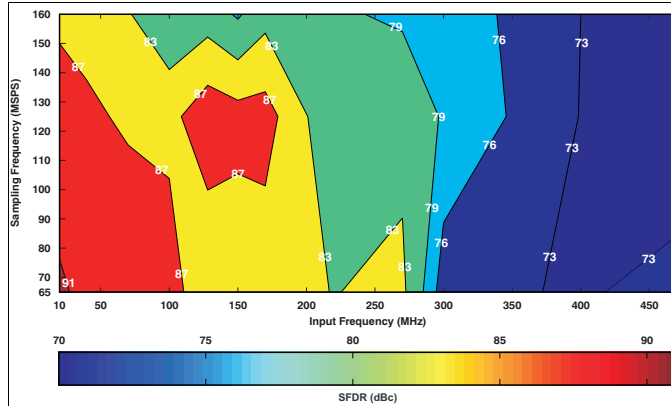

Figure 33. Spurious-Free Dynamic Range (0dB Gain)

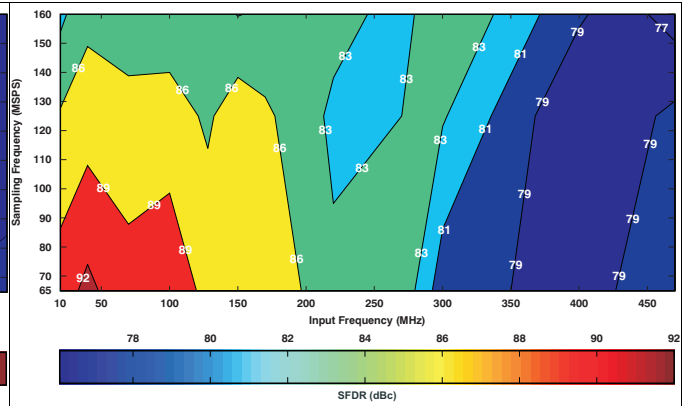

Figure 34. Spurious-Free Dynamic Range (6dB Gain)

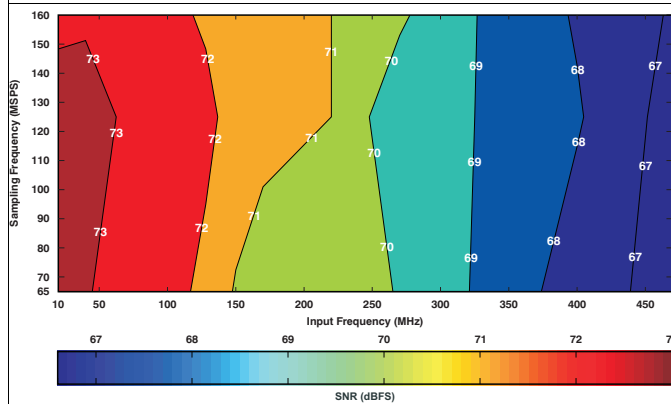

Figure 35. Signal-To-Noise Ratio (0dB Gain)

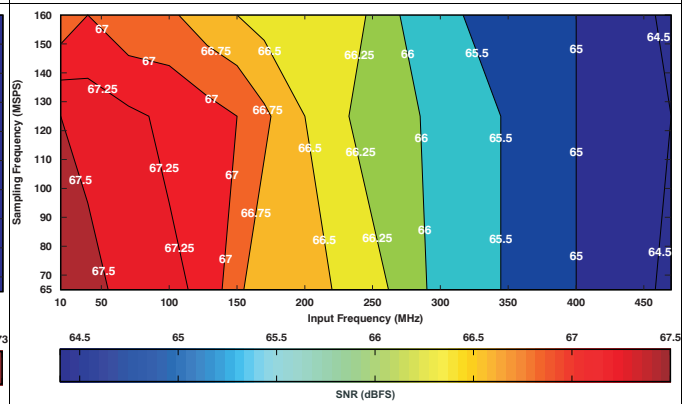

Figure 36. Signal-To-Noise Ratio (6dB Gain)

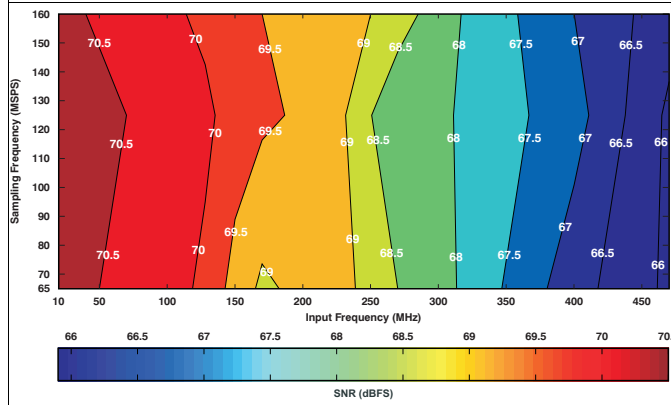

Figure 37. Signal-To-Noise Ratio (0dB Gain)

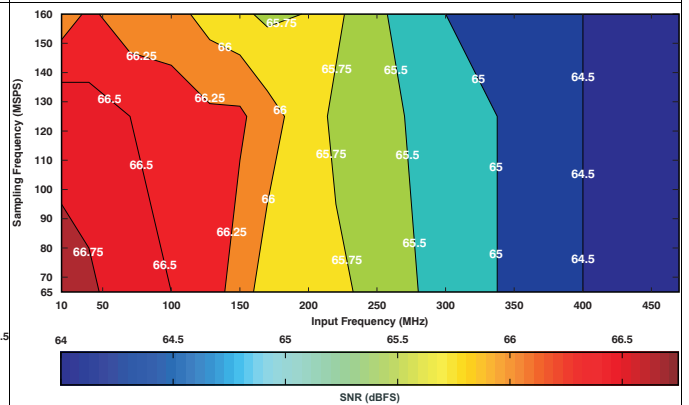

Figure 38. Signal-To-Noise Ratio (6dB Gain)

7 Detailed Description

7.1 Overview

The ADS4245 is a low-speed variant of the ADS42xx ultralow-power family of dual-channel, 14-bit analog-to-digital converters (ADCs). Innovative design techniques are used to achieve high-dynamic performance, while consuming extremely low power with 1.8V supply.

The ADS4245 has gain options that can be used to improve SFDR performance at lower full-scale input ranges. This device includes a dc offset correction loop that can be used to cancel the ADC offset.

7.2 Functional Block Diagram

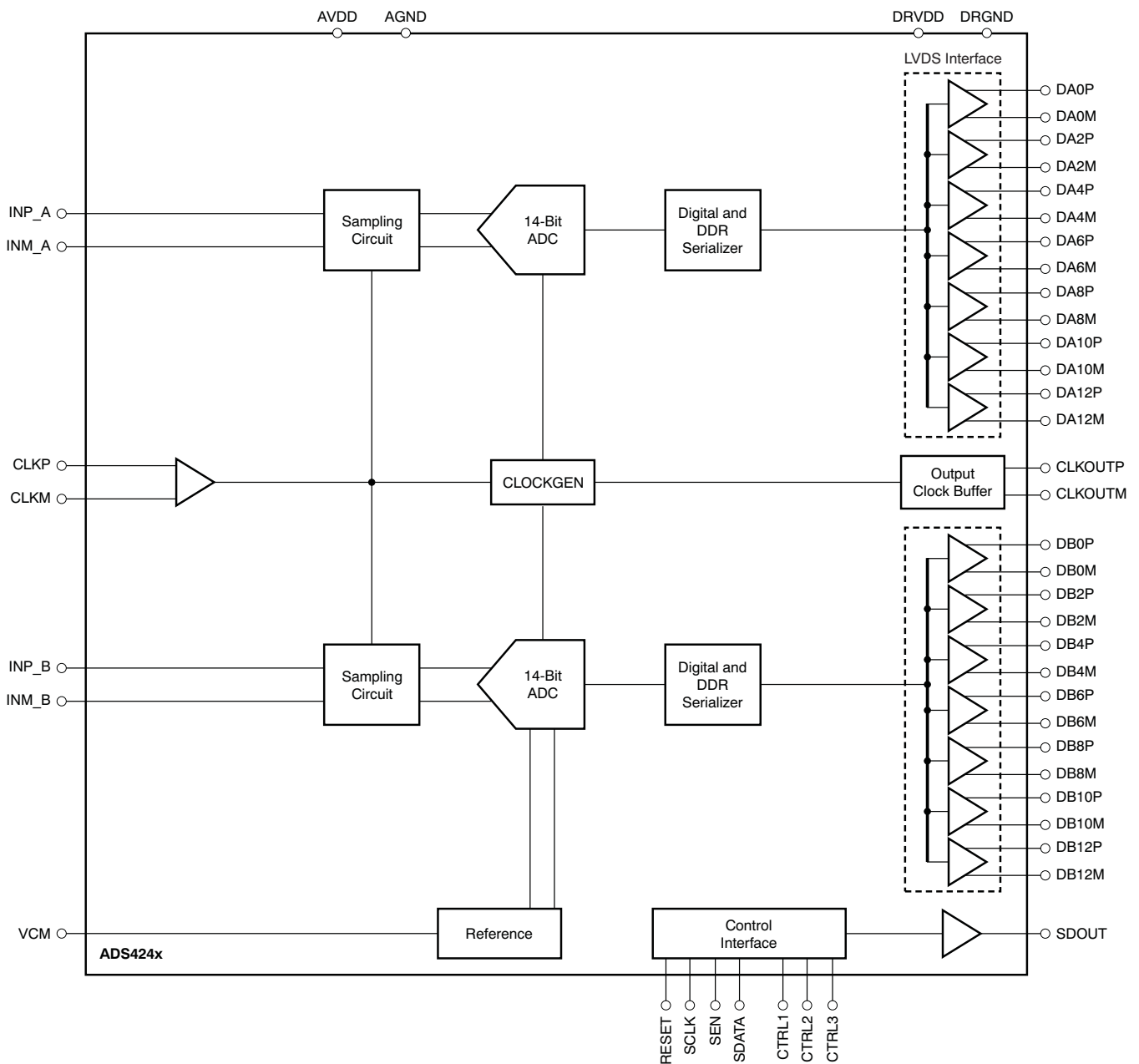

7.3 Feature Description

The ADS4245 is terminal-compatible with the previous generation ADS62P49 family of data converters; this architecture enables easy migration. However, there are some important differences between the two device generations, summarized in [Table 4](#).

Table 4. Migrating From The ADS62P49

| ADS62P49 FAMILY | ADS4245 FAMILY |
|--|--|
| TERMINALS | |
| Terminal 22 is NC (not connected) | Terminal 22 is AVDD |
| Terminals 38 and 58 are DRVDD | Terminals 38 and 58 are NC (do not connect, must be floated) |
| Terminals 39 and 59 are DRGND | Terminals 39 and 59 are NC (do not connect, must be floated) |
| SUPPLY | |
| AVDD is 3.3V | AVDD is 1.8V |
| DRVDD is 1.8V | No change |
| INPUT COMMON-MODE VOLTAGE | |
| VCM is 1.5V | VCM is 0.95V |
| SERIAL INTERFACE | |
| Protocol: 8-bit register address and 8-bit register data | No change in protocol New serial register map |
| EXTERNAL REFERENCE | |
| Supported | Not supported |

7.4 Device Functional Modes

7.4.1 Digital Functions

The device has several useful digital functions (such as test patterns, gain, and offset correction). These functions require extra clock cycles for operation and increase the overall latency and power of the device. These digital functions are disabled by default after reset and the raw ADC output is routed to the output data terminals with a latency of 16 clock cycles. [Figure 39](#) shows more details of the processing after the ADC. In order to use any of the digital functions, the EN DIGITAL bit must be set to '1'. After this, the respective register bits must be programmed as described in the following sections and in the [Serial Register Map](#) section.

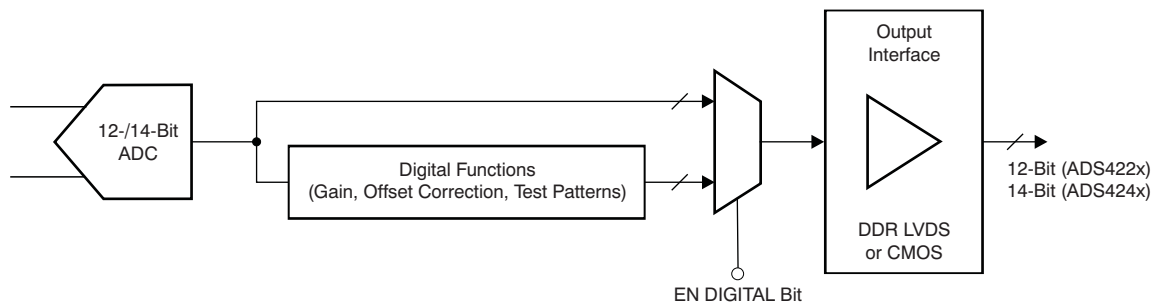

Figure 39. Digital Processing Block

7.4.2 Gain For SFDR/SNR Trade-Off

The ADS4245 includes gain settings that can be used to get improved SFDR performance (compared to no gain). The gain is programmable from 0dB to 6dB (in 0.5dB steps). For each gain setting, the analog input full-scale range scales proportionally, as shown in [Table 5](#).

The SFDR improvement is achieved at the expense of SNR; for each gain setting, the SNR degrades approximately between 0.5dB and 1dB. The SNR degradation is reduced at high input frequencies. As a result, the gain is very useful at high input frequencies because the SFDR improvement is significant with marginal degradation in SNR. Therefore, the gain can be used as a trade-off between SFDR and SNR. Note that the default gain after reset is 0dB.

Device Functional Modes (continued)
Table 5. Full-Scale Range Across Gains

| GAIN (dB) | TYPE | FULL-SCALE (V_{PP}) |
|-----------|---------------------|-------------------------|
| 0 | Default after reset | 2 |
| 1 | Fine, programmable | 1.78 |
| 2 | Fine, programmable | 1.59 |
| 3 | Fine, programmable | 1.42 |
| 4 | Fine, programmable | 1.26 |
| 5 | Fine, programmable | 1.12 |
| 6 | Fine, programmable | 1 |

7.4.3 Offset Correction

The ADS4245 has an internal offset correction algorithm that estimates and corrects dc offset up to $\pm 10\text{mV}$. The correction can be enabled using the ENABLE OFFSET CORR serial register bit. Once enabled, the algorithm estimates the channel offset and applies the correction every clock cycle. The time constant of the correction loop is a function of the sampling clock frequency. The time constant can be controlled using the OFFSET CORR TIME CONSTANT register bits, as described in [Table 6](#).

After the offset is estimated, the correction can be frozen by setting FREEZE OFFSET CORR = 0. Once frozen, the last estimated value is used for the offset correction of every clock cycle. Note that offset correction is disabled by default after reset.

Table 6. Time Constant Of Offset Correction Algorithm

| OFFSET CORR TIME CONSTANT | TIME CONSTANT, TC_{CLK} (Number of Clock Cycles) | TIME CONSTANT, $TC_{CLK} \times 1/f_S$ (ms) ⁽¹⁾ |
|---------------------------|---|--|
| 0000 | 1M | 7 |
| 0001 | 2M | 13 |
| 0010 | 4M | 26 |
| 0011 | 8M | 52 |
| 0100 | 16M | 105 |
| 0101 | 32M | 210 |
| 0110 | 64M | 419 |
| f0111 | 128M | 839 |
| 1000 | 256M | 1678 |
| 1001 | 512M | 3355 |
| 1010 | 1G | 6711 |
| 1011 | 2G | 13422 |
| 1100 | Reserved | — |
| 1101 | Reserved | — |
| 1110 | Reserved | — |
| 1111 | Reserved | — |

(1) Sampling frequency, $f_S = 160\text{MSPS}$.

7.4.4 Power-Down

The ADS4245 has two power-down modes: global power-down and channel standby. These modes can be set using either the serial register bits or using the control terminals CTRL1 to CTRL3 (as shown in [Table 7](#)).

Table 7. Power-Down Settings

| CTRL1 | CTRL2 | CTRL3 | DESCRIPTION |
|-------|-------|-------|---|
| Low | Low | Low | Default |
| Low | Low | High | Not available |
| Low | High | Low | Not available |
| Low | High | High | Not available |
| High | Low | Low | Global power-down |
| High | Low | High | Channel A powered down, channel B is active |
| High | High | Low | Not available |
| High | High | High | MUX mode of operation, channel A and B data is multiplexed and output on DB[10:0] terminals |

7.4.4.1 Global Power-Down

In this mode, the entire chip (including ADCs, internal reference, and output buffers) are powered down, resulting in reduced total power dissipation of approximately 20mW when the CTRL terminals are used and 3mW when the PDN GLOBAL serial register bit is used. The output buffers are in high-impedance state. The wake-up time from global power-down to data becoming valid in normal mode is typically 100µs.

7.4.4.2 Channel Standby

In this mode, each ADC channel can be powered down. The internal references are active, resulting in a quick wake-up time of 50µs. The total power dissipation in standby is approximately 200mW at 160MSPS.

7.4.4.3 Input Clock Stop

In addition to the previous modes, the converter enters a low-power mode when the input clock frequency falls below 1MSPS. The power dissipation is approximately 160mW.

7.4.5 Digital Output Information

The ADS4245 provides 14-bit digital data for each channel and an output clock synchronized with the data.

7.4.5.1 Output Interface

Two output interface options are available: double data rate (DDR) LVDS and parallel CMOS. They can be selected using the serial interface register bit or by setting the proper voltage on the SEN terminal in parallel configuration mode.

7.4.5.2 DDR LVDS Outputs

In this mode, the data bits and clock are output using low-voltage differential signal (LVDS) levels. Two data bits are multiplexed and output on each LVDS differential pair, as shown in [Figure 40](#).

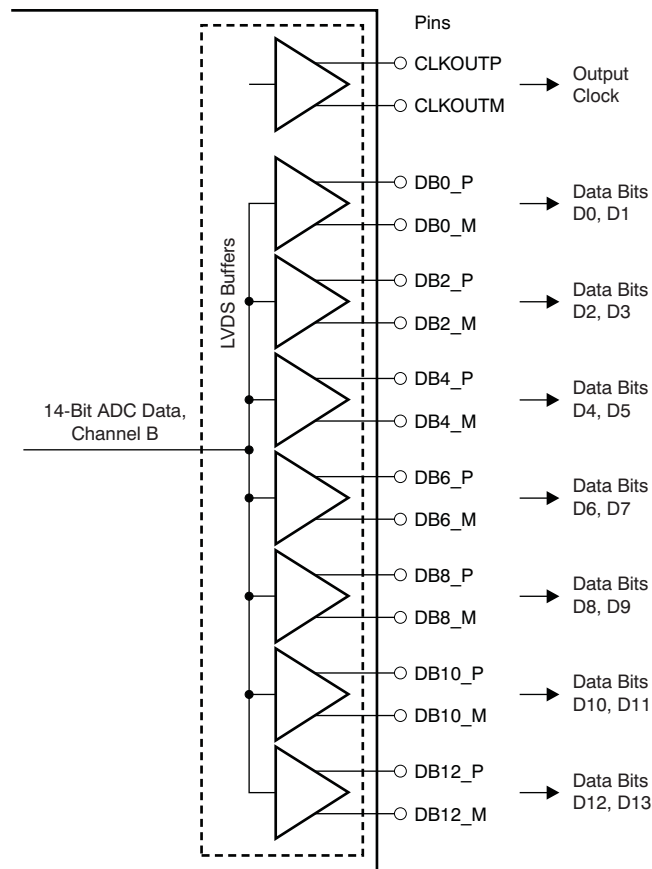

Figure 40. LVDS Interface

Even data bits (D0, D2, D4, etc.) are output at the CLKOUTP rising edge and the odd data bits (D1, D3, D5, etc.) are output at the CLKOUTP falling edge. Both the CLKOUTP rising and falling edges must be used to capture all the data bits, as shown in Figure 41.

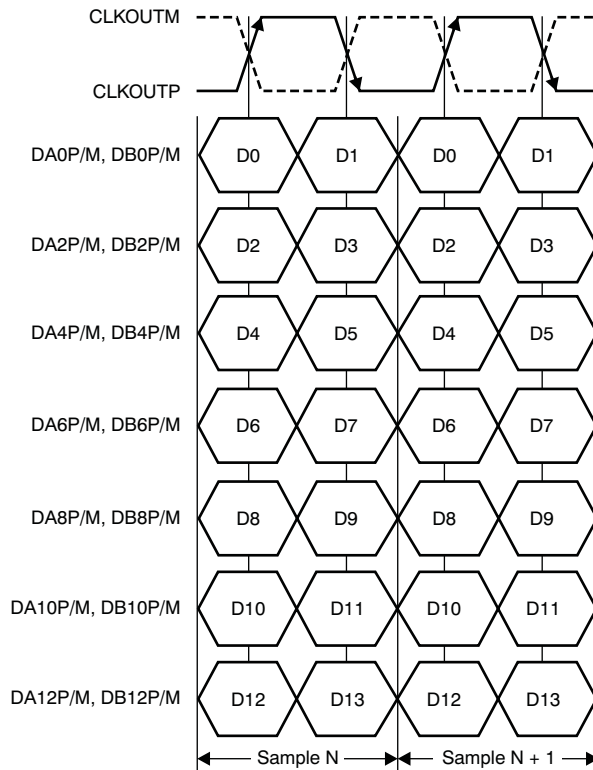
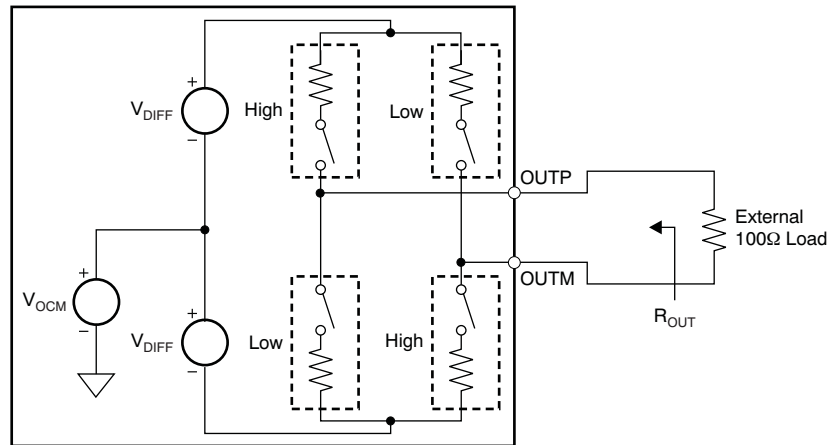

Figure 41. DDR LVDS Interface Timing

7.4.5.3 LVDS Buffer

The equivalent circuit of each LVDS output buffer is shown in Figure 42. After reset, the buffer presents an output impedance of 100Ω to match with the external 100Ω termination.



NOTE: Default swing across 100Ω load is ±350mV. Use the LVDS SWING bits to change the swing.

Figure 42. LVDS Buffer Equivalent Circuit

The V_{DIFF} voltage is nominally 350mV, resulting in an output swing of ±350mV with 100Ω external termination. The V_{DIFF} voltage is programmable using the LVDS SWING register bits from ±125mV to ±570mV.

Additionally, a mode exists to double the strength of the LVDS buffer to support 50Ω differential termination, as shown in Figure 43. This mode can be used when the output LVDS signal is routed to two separate receiver chips, each using a 100Ω termination. The mode can be enabled using the LVDS DATA STRENGTH and LVDS CLKOUT STRENGTH register bits for data and output clock buffers, respectively.

The buffer output impedance behaves in the same way as a source-side series termination. By absorbing reflections from the receiver end, it helps to improve signal integrity.

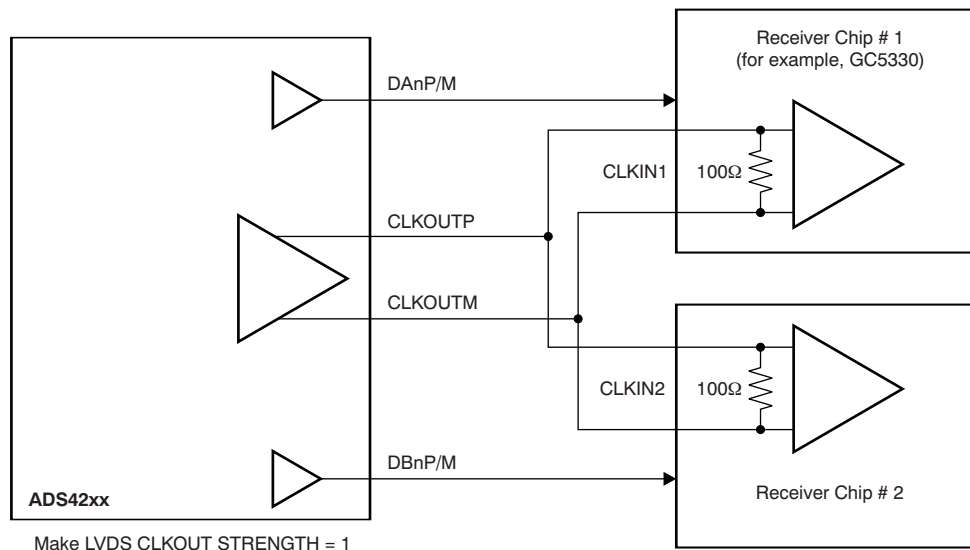

Figure 43. LVDS Buffer Differential Termination

7.4.5.4 Parallel CMOS Interface

In the CMOS mode, each data bit is output on separate terminals as CMOS voltage level, every clock cycle, as Figure 44 shows. The rising edge of the output clock CLKOUT can be used to latch data in the receiver. It is recommended to minimize the load capacitance of the data and clock output terminals by using short traces to the receiver. Furthermore, match the output data and clock traces to minimize the skew between them.

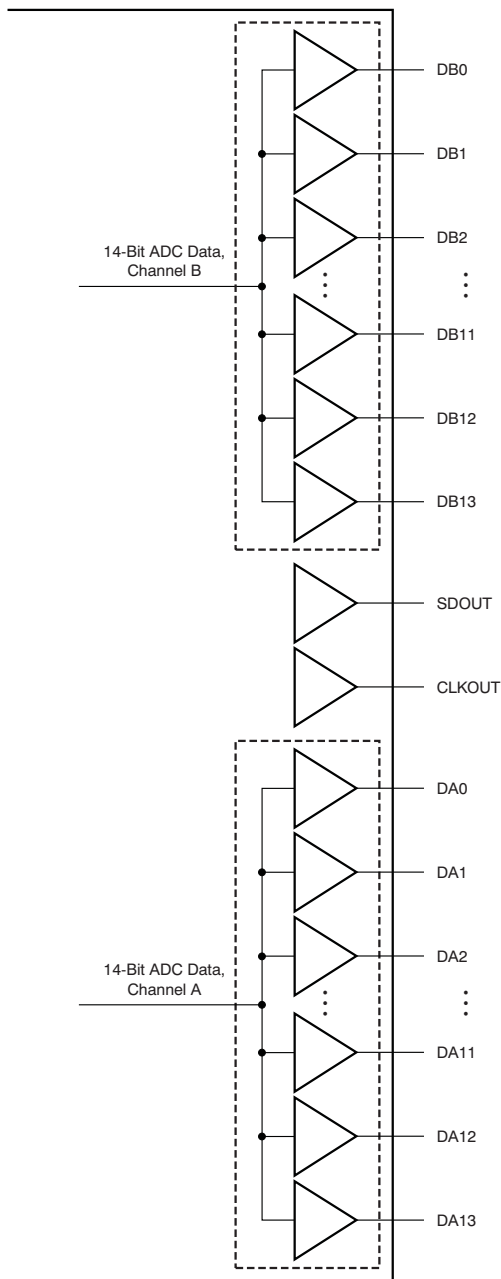

Figure 44. CMOS Outputs

7.4.5.5 CMOS Interface Power Dissipation

With CMOS outputs, the DRVDD current scales with the sampling frequency and the load capacitance on every output terminal. The maximum DRVDD current occurs when each output bit toggles between 0 and 1 every clock cycle. In actual applications, this condition is unlikely to occur. The actual DRVDD current would be determined by the average number of output bits switching, which is a function of the sampling frequency and the nature of the analog input signal. This relationship is shown by the formula:

$$\text{Digital current as a result of CMOS output switching} = C_L \times \text{DRVDD} \times (N \times F_{\text{AVG}}),$$

where C_L = load capacitance, $N \times F_{\text{AVG}}$ = average number of output bits switching.

7.4.5.6 Multiplexed Mode Of Operation

In this mode, the digital outputs of both channels are multiplexed and output on a single bus (DB[13:0] terminals), as shown in Figure 45. The channel A output terminals (DA[13:0]) are in 3-state. Because the output data rate on the DB bus is effectively doubled, this mode is recommended only for low sampling frequencies (less than 80MSPS). This mode can be enabled using the POWER-DOWN MODE register bits or using the CTRL[3:1] parallel terminals.

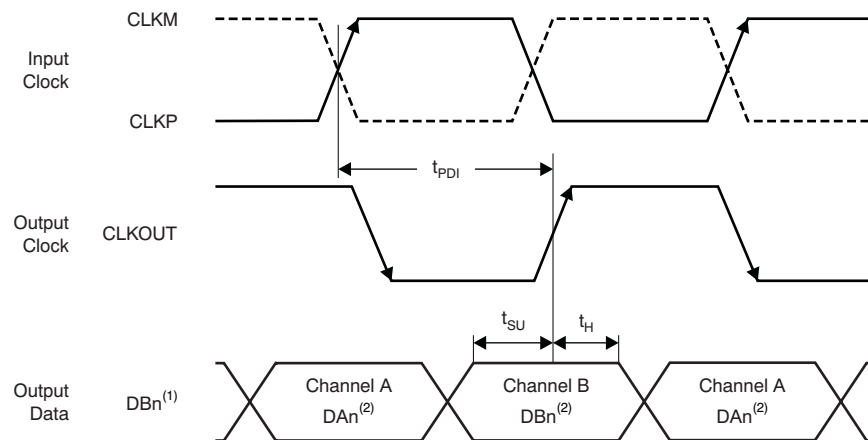

(1) In multiplexed mode, both channels outputs come on the channel B output terminals.

(2) Dn = bits D0, D1, D2, etc.

Figure 45. Multiplexed Mode Timing Diagram

7.4.5.7 Output Data Format

Two output data formats are supported: twos complement and offset binary. The format can be selected using the DATA FORMAT serial interface register bit or by controlling the DFS terminal in parallel configuration mode.

In the event of an input voltage overdrive, the digital outputs go to the appropriate full-scale level. For a positive overdrive, the output code is FFFh for the ADS422x and 3FFFh for the ADS424x in offset binary output format; the output code is 7FFh for the ADS422x and 1FFFh for the ADS424x in twos complement output format. For a negative input overdrive, the output code is 0000h in offset binary output format and 800h for the ADS422x and 2000h for the ADS424x in twos complement output format.

7.5 Device Configuration

The ADS4245 can be configured independently using either parallel interface control or serial interface programming.

7.5.1 Parallel Configuration Only

To put the device into parallel configuration mode, keep RESET tied high (AVDD). Then, use the SEN, SCLK, CTRL1, CTRL2, and CTRL3 terminals to directly control certain modes of the ADC. The device can be easily configured by connecting the parallel terminals to the correct voltage levels (as described in Table 8 to Table 11). There is no need to apply a reset and SDATA can be connected to ground.

Device Configuration (continued)

In this mode, SEN and SCLK function as parallel interface control terminals. Some frequently-used functions can be controlled using these terminals. [Table 8](#) describes the modes controlled by the parallel terminals.

Table 8. Parallel Terminal Definition

| TERMINAL | CONTROL MODE |
|----------|--|
| SCLK | Low-speed mode selection |
| SEN | Output data format and output interface selection |
| CTRL1 | Together, these terminals control the power-down modes |
| CTRL2 | |
| CTRL3 | |

7.5.2 Serial Interface Configuration Only

To enable this mode, the serial registers must first be reset to the default values and the RESET terminal must be kept low. SEN, SDATA, and SCLK function as serial interface terminals in this mode and can be used to access the internal registers of the ADC. The registers can be reset either by applying a pulse on the RESET terminal or by setting the RESET bit high. The [Serial Register Map](#) section describes the register programming and the register reset process in more detail.

7.5.3 Using Both Serial Interface And Parallel Controls

For increased flexibility, a combination of serial interface registers and parallel terminal controls (CTRL1 to CTRL3) can also be used to configure the device. To enable this option, keep RESET low. The parallel interface control terminals CTRL1 to CTRL3 are available. After power-up, the device is automatically configured according to the voltage settings on these terminals (see [Table 11](#)). SEN, SDATA, and SCLK function as serial interface digital terminals and are used to access the internal registers of the ADC. The registers must first be reset to the default values either by applying a pulse on the RESET terminal or by setting the RESET bit to '1'. After reset, the RESET terminal must be kept low. The [Serial Register Map](#) section describes register programming and the register reset process in more detail.

7.5.4 Parallel Configuration Details

The functions controlled by each parallel terminal are described in [Table 9](#), [Table 10](#), and [Table 11](#). A simple way of configuring the parallel terminals is shown in [Figure 46](#).

Table 9. SCLK Control Terminal

| VOLTAGE APPLIED ON SCLK | DESCRIPTION |
|-------------------------|--|
| Low | Low-speed mode is disabled |
| High | Low-speed mode is enabled ⁽¹⁾ |

(1) Low-speed mode is enabled in the ADS4222/42 by default.

Table 10. SEN Control Terminal

| VOLTAGE APPLIED ON SEN | DESCRIPTION |
|------------------------|--|
| 0 (+50mV/0mV) | Twos complement and parallel CMOS output |
| (3/8) AVDD (±50mV) | Offset binary and parallel CMOS output |
| (5/8) 2AVDD (±50mV) | Offset binary and DDR LVDS output |
| AVDD (0mV/–50mV) | Twos complement and DDR LVDS output |

Table 11. CTRL1, CTRL2, And CTRL3 Terminals

| CTRL1 | CTRL2 | CTRL3 | DESCRIPTION |
|-------|-------|-------|---|
| Low | Low | Low | Normal operation |
| Low | Low | High | Not available |
| Low | High | Low | Not available |
| Low | High | High | Not available |
| High | Low | Low | Global power-down |
| High | Low | High | Channel A standby, channel B is active |
| High | High | Low | Not available |
| High | High | High | MUX mode of operation, channel A and B data are multiplexed and output on the DB[13:0] terminals. |

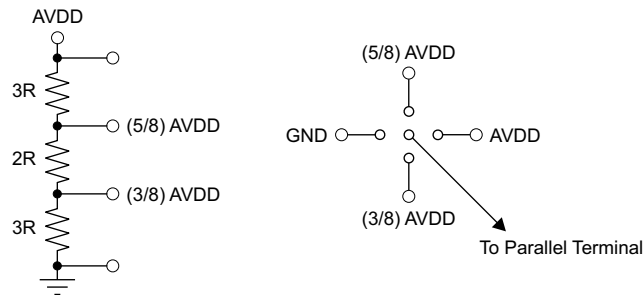

Figure 46. Simple Scheme To Configure The Parallel Terminals

7.5.5 Serial Interface Details

The ADC has a set of internal registers that can be accessed by the serial interface formed by the SEN (serial interface enable), SCLK (serial interface clock), and SDATA (serial interface data) terminals. Serial shift of bits into the device is enabled when SEN is low. Serial data SDATA are latched at every SCLK falling edge when SEN is active (low). The serial data are loaded into the register at every 16th SCLK falling edge when SEN is low. When the word length exceeds a multiple of 16 bits, the excess bits are ignored. Data can be loaded in multiples of 16-bit words within a single active SEN pulse. The first eight bits form the register address and the remaining eight bits are the register data. The interface can work with SCLK frequencies from 20MHz down to very low speeds (of a few hertz) and also with non-50% SCLK duty cycle.

7.5.5.1 Register Initialization

After power-up, the internal registers must be initialized to the default values. Initialization can be accomplished in one of two ways:

1. Either through hardware reset by applying a high pulse on the RESET terminal (of width greater than 10ns), as shown in Figure 47; or
2. By applying a software reset. When using the serial interface, set the RESET bit high. This setting initializes the internal registers to the default values and then self-resets the RESET bit low. In this case, the RESET terminal is kept low.

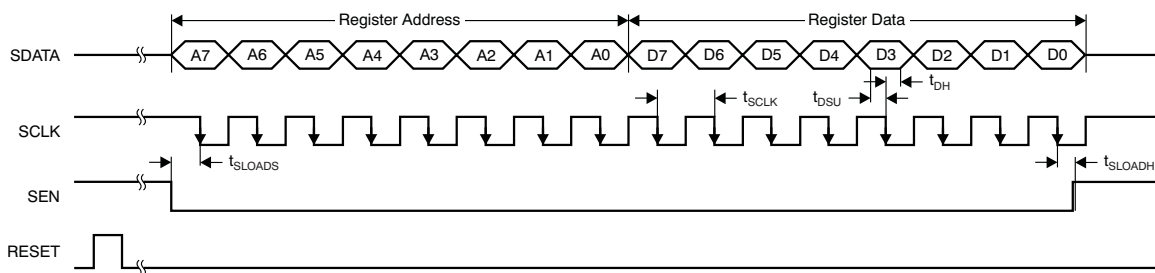

Figure 47. Serial Interface Timing

Table 12. Serial Interface Timing Characteristics⁽¹⁾

| PARAMETER | | MIN | TYP | MAX | UNIT |
|--------------|---|------|-----|-----|------|
| f_{SCLK} | SCLK frequency (equal to $1/t_{SCLK}$) | > DC | | 20 | MHz |
| t_{SLOADS} | SEN to SCLK setup time | 30 | | | ns |
| t_{SLOADH} | SCLK to SEN hold time | 30 | | | ns |
| t_{DSU} | SDATA setup time | 30 | | | ns |
| t_{DH} | SDATA hold time | 30 | | | ns |

(1) Typical values at +25°C; minimum and maximum values across the full temperature range: $T_{MIN} = -55^{\circ}C$ to $T_{MAX} = +125^{\circ}C$, $AVDD = 1.8V$, and $DRVDD = 1.8V$, unless otherwise noted.

7.5.5.2 Serial Register Readout

The device includes a mode where the contents of the internal registers can be read back. This readback mode may be useful as a diagnostic check to verify the serial interface communication between the external controller and the ADC. To use readback mode, follow this procedure:

1. Set the READOUT register bit to '1'. This setting disables any further writes to the registers.
2. Initiate a serial interface cycle specifying the address of the register (A7 to A0) whose content has to be read.
3. The device outputs the contents (D7 to D0) of the selected register on the SDOUT terminal (terminal 64).
4. The external controller can latch the contents at the SCLK falling edge.
5. To enable register writes, reset the READOUT register bit to '0'.

The serial register readout works with both CMOS and LVDS interfaces on terminal 64.

When READOUT is disabled, the SDOUT terminal is in high-impedance state. If serial readout is not used, the SDOUT terminal must float.

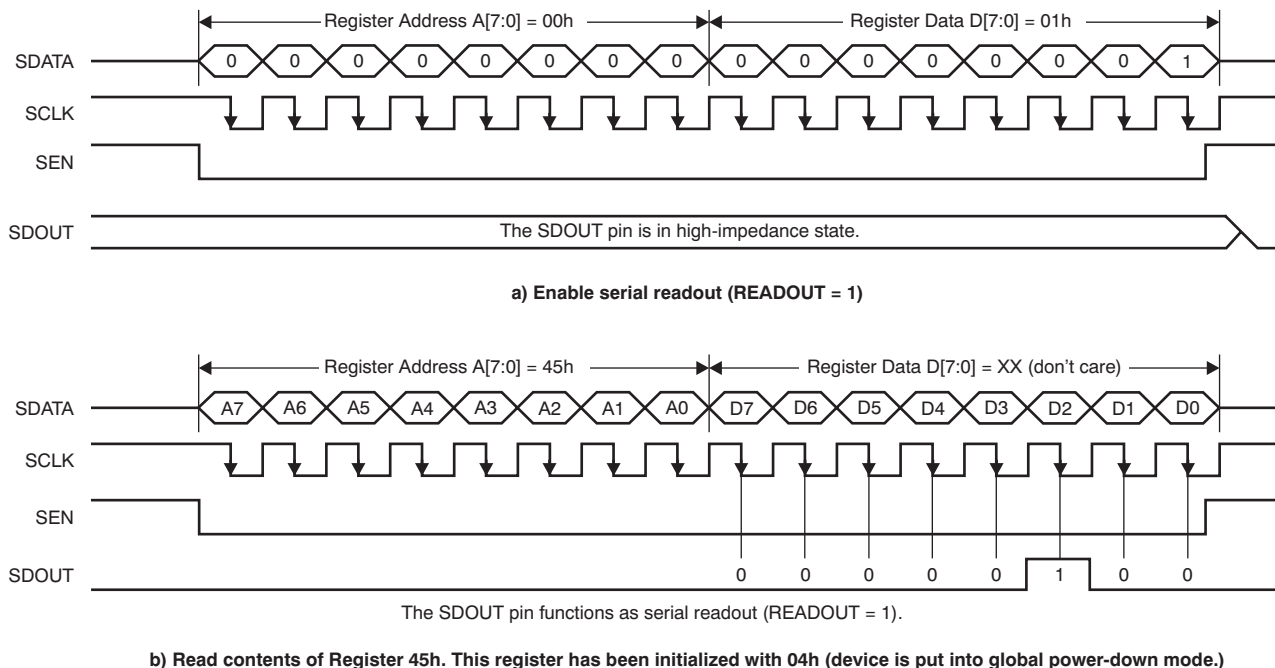
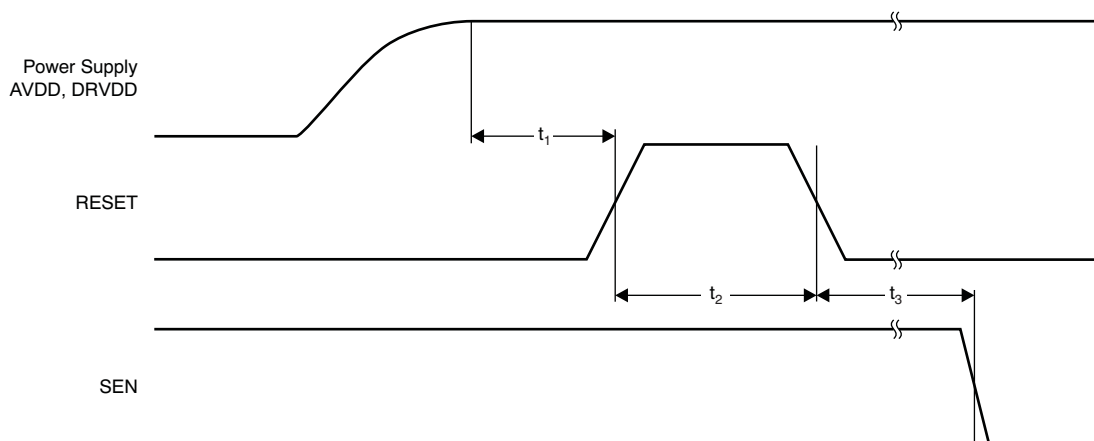

Figure 48. Serial Readout Timing Diagram

Table 13. Reset Timing (Only When Serial Interface Is Used)⁽¹⁾

| PARAMETER | | CONDITIONS | MIN | TYP | MAX | UNIT |
|----------------|----------------------|--|-----|-----|-----|------|
| t ₁ | Power-on delay | Delay from AVDD and DRVDD power-up to active RESET pulse | 1 | | | ms |
| t ₂ | Reset pulse width | Active RESET signal pulse width | 100 | | | ns |
| | | | | | 1 | µs |
| t ₃ | Register write delay | Delay from RESET disable to SEN active | 350 | | | ns |

(1) Typical values at +25°C; minimum and maximum values across the full temperature range: T_{MIN} = -55°C to T_{MAX} = +125°C, unless otherwise noted.



NOTE: A high pulse on the RESET terminal is required in the serial interface mode when initialized through a hardware reset. For parallel interface operation, RESET must be permanently tied high.

Figure 49. Reset Timing Diagram

7.6 Serial Register Map

Table 14 summarizes the functions supported by the serial interface.

Table 14. Serial Interface Register Map⁽¹⁾

| REGISTER ADDRESS | REGISTER DATA | | | | | | | |
|------------------|-----------------------|----------------------|---------------------------|-------------------|---------------------|--------------------|----------------|------------------------------------|
| A[7:0] (Hex) | D7 | D6 | D5 | D4 | D3 | D2 | D1 | D0 |
| 00 | 0 | 0 | 0 | 0 | 0 | 0 | RESET | READOUT |
| 01 | LVDS SWING | | | | | | 0 | 0 |
| 03 | 0 | 0 | 0 | 0 | 0 | 0 | HIGH PERF MODE | |
| 25 | CH A GAIN | | | | 0 | CH A TEST PATTERNS | | |
| 29 | 0 | 0 | 0 | DATA FORMAT | | 0 | 0 | 0 |
| 2B | CH B GAIN | | | | 0 | CH B TEST PATTERNS | | |
| 3D | 0 | 0 | ENABLE OFFSET CORR | 0 | 0 | 0 | 0 | 0 |
| 3F | 0 | 0 | CUSTOM PATTERN D[13:8] | | | | | |
| 40 | CUSTOM PATTERN D[7:0] | | | | | | | |
| 41 | LVDS CMOS | | CMOS CLKOUT STRENGTH | | 0 | 0 | DIS OBUF | |
| 42 | CLKOUT FALL POSN | | CLKOUT RISE POSN | | EN DIGITAL | 0 | 0 | 0 |
| 45 | STBY | LVDS CLKOUT STRENGTH | LVDS DATA STRENGTH | 0 | 0 | PDN GLOBAL | 0 | 0 |
| 4A | 0 | 0 | 0 | 0 | 0 | 0 | 0 | HIGH FREQ MODE CH B ⁽²⁾ |
| 58 | 0 | 0 | 0 | 0 | 0 | 0 | 0 | HIGH FREQ MODE CH A ⁽²⁾ |
| BF | CH A OFFSET PEDESTAL | | | | | | 0 | 0 |
| C1 | CH B OFFSET PEDESTAL | | | | | | 0 | 0 |
| CF | FREEZE OFFSET CORR | 0 | OFFSET CORR TIME CONSTANT | | | | 0 | 0 |
| DB | 0 | 0 | 0 | 0 | 0 | 0 | 0 | LOW SPEED MODE CH B |
| EF | 0 | 0 | 0 | EN LOW SPEED MODE | 0 | 0 | 0 | 0 |
| F1 | 0 | 0 | 0 | 0 | 0 | 0 | EN LVDS SWING | |
| F2 | 0 | 0 | 0 | 0 | LOW SPEED MODE CH A | 0 | 0 | 0 |

(1) Multiple functions in a register can be programmed in a single write operation. All registers default to '0' after reset.

(2) These bits improve SFDR on high frequencies. The frequency limit is 200MHz.

7.7 Description Of Serial Registers

| 7 | 6 | 5 | 4 | 3 | 2 | 1 | 0 |
|---|---|---|---|---|---|-------|---------|
| 0 | 0 | 0 | 0 | 0 | 0 | RESET | READOUT |

Bits[7:2] Always write '0'

Bit 1 RESET: Software reset applied

This bit resets all internal registers to the default values and self-clears to 0 (default = 1).

Bit 0 READOUT: Serial readout

This bit sets the serial readout of the registers.

0 = Serial readout of registers disabled; the SDOOUT terminal is placed in high-impedance state.

1 = Serial readout enabled; the SDOOUT terminal functions as a serial data readout with CMOS logic levels running from the DRVDD supply. See the [Serial Register Readout](#) section.

| 7 | 6 | 5 | 4 | 3 | 2 | 1 | 0 |
|------------|---|---|---|---|---|---|---|
| LVDS SWING | | | | | | 0 | 0 |

Bits[7:2] LVDS SWING: LVDS swing programmability

These bits program the LVDS swing. Set the EN LVDS SWING bit to '1' before programming swing.

000000 = Default LVDS swing; $\pm 350\text{mV}$ with external 100Ω termination

011011 = LVDS swing increases to $\pm 410\text{mV}$

110010 = LVDS swing increases to $\pm 465\text{mV}$

010100 = LVDS swing increases to $\pm 570\text{mV}$

111110 = LVDS swing decreases to $\pm 200\text{mV}$

001111 = LVDS swing decreases to $\pm 125\text{mV}$

Bits[1:0] Always write '0'

| 7 | 6 | 5 | 4 | 3 | 2 | 1 | 0 |
|---|---|---|---|---|---|----------------|---|
| 0 | 0 | 0 | 0 | 0 | 0 | HIGH PERF MODE | |

Bits[7:2] Always write '0'

Bits[1:0] HIGH PERF MODE: High-performance mode

00 = Default performance

01 = Do not use

10 = Do not use

11 = Obtain best performance across sample clock and input signal frequencies

| 7 | 6 | 5 | 4 | 3 | 2 | 1 | 0 |
|-----------|---|---|---|---|--------------------|---|---|
| CH A GAIN | | | | 0 | CH A TEST PATTERNS | | |

Bits[7:4] CH A GAIN: Channel A gain programmability

These bits set the gain programmability in 0.5dB steps for channel A.

0000 = 0dB gain (default after reset)

0001 = 0.5dB gain

0010 = 1dB gain

0011 = 1.5dB gain

0100 = 2dB gain

0101 = 2.5dB gain

0110 = 3dB gain

0111 = 3.5dB gain

1000 = 4dB gain

1001 = 4.5dB gain

1010 = 5dB gain

1011 = 5.5dB gain

1100 = 6dB gain

Bit 3 Always write '0'
Bits[2:0] CH A TEST PATTERNS: Channel A data capture

These bits verify data capture for channel A.

000 = Normal operation

001 = Outputs all 0s

010 = Outputs all 1s

011 = Outputs toggle pattern.

Output data D[13:0] are an alternating sequence of *10101010101010* and *01010101010101*.

100 = Outputs digital ramp.

Output data increment by one LSB (14-bit) every clock cycle from code 0 to code 16383.

101 = Outputs custom pattern; use registers 3Fh and 40h to set the custom pattern

110 = Unused

111 = Unused

| 7 | 6 | 5 | 4 | 3 | 2 | 1 | 0 |
|---|---|---|-------------|---|---|---|---|
| 0 | 0 | 0 | DATA FORMAT | | 0 | 0 | 0 |

Bits[7:5] Always write '0'
Bits[4:3] DATA FORMAT: Data format selection

00 = Twos complement

01 = Twos complement

10 = Twos complement

11 = Offset binary

Bits[2:0] Always write '0'

| 7 | 6 | 5 | 4 | 3 | 2 | 1 | 0 |
|-----------|---|---|---|---|--------------------|---|---|
| CH B GAIN | | | | 0 | CH B TEST PATTERNS | | |

Bits[7:4] CH B GAIN: Channel B gain programmability

These bits set the gain programmability in 0.5dB steps for channel B.

0000 = 0dB gain (default after reset)
 0001 = 0.5dB gain
 0010 = 1dB gain
 0011 = 1.5dB gain
 0100 = 2dB gain
 0101 = 2.5dB gain
 0110 = 3dB gain
 0111 = 3.5dB gain
 1000 = 4dB gain
 1001 = 4.5dB gain
 1010 = 5dB gain
 1011 = 5.5dB gain
 1100 = 6dB gain

Bit 3 Always write '0'

Bits[2:0] CH B TEST PATTERNS: Channel B data capture

These bits verify data capture for channel B.

000 = Normal operation
 001 = Outputs all 0s
 010 = Outputs all 1s
 011 = Outputs toggle pattern.
 Output data D[13:0] are an alternating sequence of *10101010101010* and *01010101010101*.
 100 = Outputs digital ramp.
 Output data increment by one LSB (14-bit) every clock cycle from code 0 to code 16383.
 101 = Outputs custom pattern; use registers 3Fh and 40h to set the custom pattern
 110 = Unused
 111 = Unused

| 7 | 6 | 5 | 4 | 3 | 2 | 1 | 0 |
|---|---|--------------------------|---|---|---|---|---|
| 0 | 0 | ENABLE OFFSET CORR | 0 | 0 | 0 | 0 | 0 |

Bits[7:6] Always write '0'

Bit 5 ENABLE OFFSET CORR: Offset correction setting

This bit enables the offset correction.

0 = Offset correction disabled
 1 = Offset correction enabled

Bits[4:0] Always write '0'

| 7 | 6 | 5 | 4 | 3 | 2 | 1 | 0 |
|---|---|-----------------------|-----------------------|-----------------------|-----------------------|----------------------|----------------------|
| 0 | 0 | CUSTOM PATTERN D13 | CUSTOM PATTERN D12 | CUSTOM PATTERN D11 | CUSTOM PATTERN D10 | CUSTOM PATTERN D9 | CUSTOM PATTERN D8 |

Bits[7:6] Always write '0'

Bits[5:0] CUSTOM PATTERN D[13:8]

These are the six upper bits of the custom pattern available at the output instead of ADC data.

| | | | | | | | |
|---|---|---|---|---|---|---|---|
| 7 | 6 | 5 | 4 | 3 | 2 | 1 | 0 |
|---|---|---|---|---|---|---|---|

Bits[7:0] CUSTOM PATTERN D[7:0]

These are the eight upper bits of the custom pattern available at the output instead of ADC data.

| | | | | | | | |
|-----------|---|----------------------|---|---|---|----------|---|
| 7 | 6 | 5 | 4 | 3 | 2 | 1 | 0 |
| LVDS CMOS | | CMOS CLKOUT STRENGTH | | 0 | 0 | DIS OBUF | |

Bits[7:6] LVDS CMOS: Interface selection

These bits select the interface.

00 = DDR LVDS interface

01 = DDR LVDS interface

10 = DDR LVDS interface

11 = Parallel CMOS interface

Bits[5:4] CMOS CLKOUT STRENGTH

These bits control the strength of the CMOS output clock.

00 = Maximum strength (recommended)

01 = Medium strength

10 = Low strength

11 = Very low strength

Bits[3:2] Always write '0'
Bits[1:0] DIS OBUF

These bits power down data and clock output buffers for both the CMOS and LVDS output interface. When powered down, the output buffers are in 3-state.

00 = Default

01 = Power-down data output buffers for channel B

10 = Power-down data output buffers for channel A

11 = Power-down data output buffers for both channels as well as the clock output buffer

| | | | | | | | |
|------------------|---|------------------|---|------------|---|---|---|
| 7 | 6 | 5 | 4 | 3 | 2 | 1 | 0 |
| CLKOUT FALL POSN | | CLKOUT RISE POSN | | EN DIGITAL | 0 | 0 | 0 |

Bits[7:6] CLKOUT FALL POSN

In LVDS mode:

00 = Default

01 = The falling edge of the output clock advances by 450 ps

10 = The falling edge of the output clock advances by 150 ps

11 = The falling edge of the output clock is delayed by 550 ps

In CMOS mode:

00 = Default

01 = The falling edge of the output clock is delayed by 150 ps

10 = Do not use

11 = The falling edge of the output clock advances by 100 ps

Bits[5:6] CLKOUT RISE POSN

In LVDS mode:

00 = Default

01 = The rising edge of the output clock advances by 450 ps

10 = The rising edge of the output clock advances by 150 ps

11 = The rising edge of the output clock is delayed by 250 ps

In CMOS mode:

00 = Default

01 = The rising edge of the output clock is delayed by 150 ps

10 = Do not use

11 = The rising edge of the output clock advances by 100 ps

Bit 3 EN DIGITAL: Digital function enable

0 = All digital functions disabled

1 = All digital functions (such as test patterns, gain, and offset correction) enabled

Bits[2:0] Always write '0'

| 7 | 6 | 5 | 4 | 3 | 2 | 1 | 0 |
|------|----------------------|--------------------|---|---|------------|---|---|
| STBY | LVDS CLKOUT STRENGTH | LVDS DATA STRENGTH | 0 | 0 | PDN GLOBAL | 0 | 0 |

Bit 7 STBY: Standby setting

0 = Normal operation

1 = Both channels are put in standby; wakeup time from this mode is fast (typically 50µs).

Bit 6 LVDS CLKOUT STRENGTH: LVDS output clock buffer strength setting

0 = LVDS output clock buffer at default strength to be used with 100Ω external termination

1 = LVDS output clock buffer has double strength to be used with 50Ω external termination

Bit 5 LVDS DATA STRENGTH

0 = All LVDS data buffers at default strength to be used with 100Ω external termination

1 = All LVDS data buffers have double strength to be used with 50Ω external termination

Bits[4:3] Always write '0'
Bit 2 PDN GLOBAL

0 = Normal operation

1 = Total power down; all ADC channels, internal references, and output buffers are powered down. Wakeup time from this mode is slow (typically 100µs).

Bits[1:0] Always write '0'

| 7 | 6 | 5 | 4 | 3 | 2 | 1 | 0 |
|---|---|---|---|---|---|---|---------------------|
| 0 | 0 | 0 | 0 | 0 | 0 | 0 | HIGH FREQ MODE CH B |

Bits[7:1] Always write '0'
Bit 0 HIGH FREQ MODE CH B: High-frequency mode for channel B

0 = Default

1 = Use this mode for high input frequencies

| 7 | 6 | 5 | 4 | 3 | 2 | 1 | 0 |
|---|---|---|---|---|---|---|---------------------|
| 0 | 0 | 0 | 0 | 0 | 0 | 0 | HIGH FREQ MODE CH A |

Bits[7:1] Always write '0'

Bit 0 HIGH FREQ MODE CH A: High-frequency mode for channel A

0 = Default

1 = Use this mode for high input frequencies

| 7 | 6 | 5 | 4 | 3 | 2 | 1 | 0 | |
|----------------------|---|---|---|---|---|---|---|---|
| CH A OFFSET PEDESTAL | | | | | | | 0 | 0 |

Bits[7:2] CH A OFFSET PEDESTAL: Channel A offset pedestal selection

When the offset correction is enabled, the final converged value after the offset is corrected is the ADC midcode value. A pedestal can be added to the final converged value by programming these bits. See the [Offset Correction](#) section. Channels can be independently programmed for different offset pedestals by choosing the relevant register address.

The pedestal ranges from –32 to +31, so the output code can vary from midcode-32 to midcode+32 by adding pedestal D7-D2.

ADS4245 (Program Bits D[7:2])

011111 = Midcode+31

011110 = Midcode+30

011101 = Midcode+29

...

000000 = Midcode

111111 = Midcode-1

111110 = Midcode-2

111101 = Midcode-3

...

100000 = Midcode-32

Bits[1:0] Always write '0'

| 7 | 6 | 5 | 4 | 3 | 2 | 1 | 0 | |
|----------------------|---|---|---|---|---|---|---|---|
| CH B OFFSET PEDESTAL | | | | | | | 0 | 0 |

Bits[7:2] CH B OFFSET PEDESTAL: Channel B offset pedestal selection

When offset correction is enabled, the final converged value after the offset is corrected is the ADC midcode value. A pedestal can be added to the final converged value by programming these bits; see the [Offset Correction](#) section. Channels can be independently programmed for different offset pedestals by choosing the relevant register address.

The pedestal ranges from –32 to +31, so the output code can vary from midcode-32 to midcode+32 by adding pedestal D[7:2].

ADS424x (Program Bits D[7:2])

011111 = Midcode+31

011110 = Midcode+30

011101 = Midcode+29

...

000000 = Midcode

111111 = Midcode-1

111110 = Midcode-2

111101 = Midcode-3

...

100000 = Midcode-32

Bits[1:0] Always write '0'

| 7 | 6 | 5 | 4 | 3 | 2 | 1 | 0 |
|--------------------|---|---------------------------|---|---|---|---|---|
| FREEZE OFFSET CORR | 0 | OFFSET CORR TIME CONSTANT | | | | 0 | 0 |

Bit 7 FREEZE OFFSET CORR: Freeze offset correction setting

This bit sets the freeze offset correction estimation.

0 = Estimation of offset correction is not frozen (the EN OFFSET CORR bit must be set)

1 = Estimation of offset correction is frozen (the EN OFFSET CORR bit must be set); when frozen, the last estimated value is used for offset correction of every clock cycle. See the [Offset Correction](#) section.

Bit 6 Always write '0'
Bits[5:2] OFFSET CORR TIME CONSTANT

The offset correction loop time constant in number of clock cycles. Refer to the [Offset Correction](#) section.

Bits[1:0] Always write '0'

| 7 | 6 | 5 | 4 | 3 | 2 | 1 | 0 |
|---|---|---|---|---|---|---|---------------------|
| 0 | 0 | 0 | 0 | 0 | 0 | 0 | LOW SPEED MODE CH B |

Bits[7:1] Always write '0'
Bit 0 LOW SPEED MODE CH B: Channel B low-speed mode enable

This bit enables the low-speed mode for channel B. Set the EN LOW SPEED MODE bit to '1' before using this bit.

0 = Low-speed mode is disabled for channel B

1 = Low-speed mode is enabled for channel B

| 7 | 6 | 5 | 4 | 3 | 2 | 1 | 0 |
|---|---|---|-------------------|---|---|---|---|
| 0 | 0 | 0 | EN LOW SPEED MODE | 0 | 0 | 0 | 0 |

Bits[7:5] Always write '0'
Bit 4 EN LOW SPEED MODE: Enable control of low-speed mode through serial register bits (ADS42x5 and ADS42x6 only)

This bit enables the control of the low-speed mode using the LOW SPEED MODE CH B and LOW SPEED MODE CH A register bits.

0 = Low-speed mode is disabled

1 = Low-speed mode is controlled by serial register bits

Bits[3:0] Always write '0'

| 7 | 6 | 5 | 4 | 3 | 2 | 1 | 0 |
|---|---|---|---|---|---|---------------|---|
| 0 | 0 | 0 | 0 | 0 | 0 | EN LVDS SWING | |

Bits[7:2] Always write '0'
Bits[1:0] EN LVDS SWING: LVDS swing enable

These bits enable LVDS swing control using the LVDS SWING register bits.

00 = LVDS swing control using the LVDS SWING register bits is disabled

01 = Do not use

10 = Do not use

11 = LVDS swing control using the LVDS SWING register bits is enabled

| 7 | 6 | 5 | 4 | 3 | 2 | 1 | 0 |
|---|---|---|---|------------------------|---|---|---|
| 0 | 0 | 0 | 0 | LOW SPEED MODE CH A | 0 | 0 | 0 |

Bits[7:4] Always write '0'

Bit 3 LOW SPEED MODE CH A: Channel A low-speed mode enable

This bit enables the low-speed mode for channel A. Set the EN LOW SPEED MODE bit to '1' before using this bit.

0 = Low-speed mode is disabled for channel A

1 = Low-speed mode is enabled for channel A

Bits[2:0] Always write '0'

8 Application and Implementation

NOTE

Information in the following applications sections is not part of the TI component specification, and TI does not warrant its accuracy or completeness. TI's customers are responsible for determining suitability of components for their purposes. Customers should validate and test their design implementation to confirm system functionality.

8.1 Application Information

The ADS4245 belongs to TI's ultralow-power family of dual-channel 14-bit analog-to-digital converters (ADCs). At every rising edge of the input clock, the analog input signal of each channel is simultaneously sampled. The sampled signal in each channel is converted by a pipeline of low-resolution stages. In each stage, the sampled/held signal is converted by a high-speed, low-resolution, flash sub-ADC. The difference between the stage input and the quantized equivalent is gained and propagates to the next stage. At every clock, each succeeding stage resolves the sampled input with greater accuracy. The digital outputs from all stages are combined in a digital correction logic block and digitally processed to create the final code after a data latency of 16 clock cycles. The digital output is available as either DDR LVDS or parallel CMOS and coded in either straight offset binary or binary twos complement format. The dynamic offset of the first stage sub-ADC limits the maximum analog input frequency to approximately 400MHz (with 2V_{PP} amplitude) or approximately 600MHz (with 1V_{PP} amplitude).

8.1.1 Clock Input

The ADS4245 clock inputs can be driven differentially (sine, LVPECL, or LVDS) or single-ended (LVCMOS), with little or no difference in performance between them. The common-mode voltage of the clock inputs is set to VCM using internal 5kΩ resistors. This setting allows the use of transformer-coupled drive circuits for sine-wave clock or ac-coupling for LVPECL and LVDS clock sources are shown in Figure 50, Figure 51 and Figure 52. The internal clock buffer is shown in Figure 53.

(1) R_T = termination resistor, if necessary.

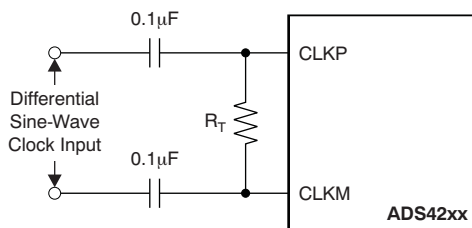

Figure 50. Differential Sine-Wave Clock Driving Circuit

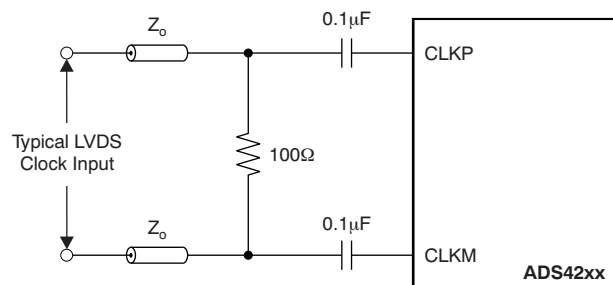

Figure 51. LVDS Clock Driving Circuit

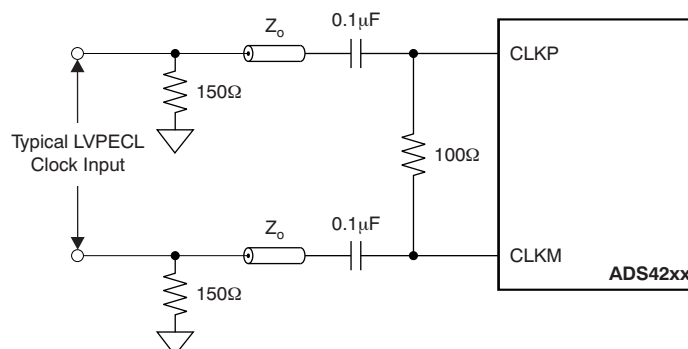
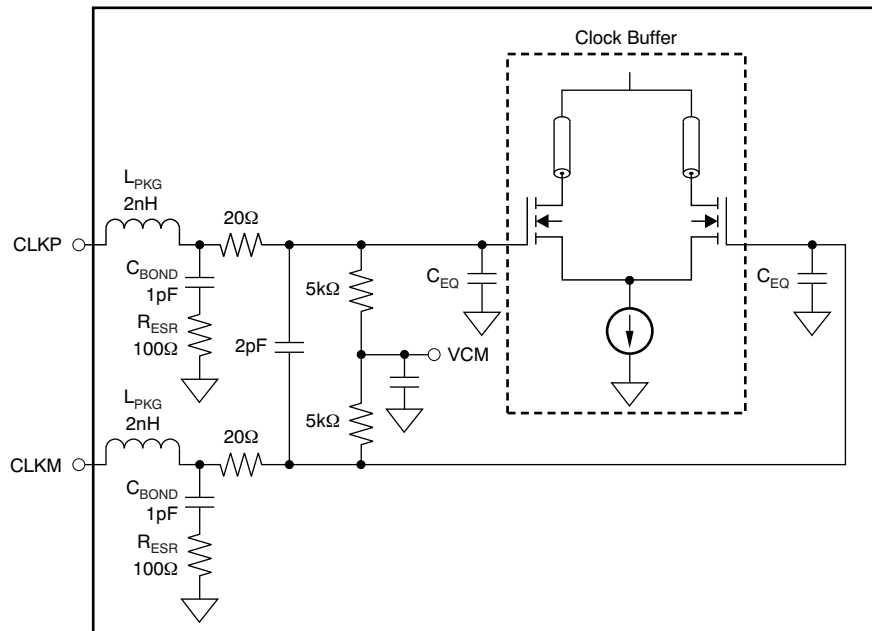

Figure 52. LVPECL Clock Driving Circuit

Application Information (continued)



NOTE: C_{EQ} is 1pF to 3pF and is the equivalent input capacitance of the clock buffer.

Figure 53. Internal Clock Buffer

A single-ended CMOS clock can be ac-coupled to the CLKP input, with CLKM connected to ground with a 0.1μF capacitor, as shown in Figure 54. For best performance, the clock inputs must be driven differentially, thereby reducing susceptibility to common-mode noise. For high input frequency sampling, it is recommended to use a clock source with very low jitter. Band-pass filtering of the clock source can help reduce the effects of jitter. There is no change in performance with a non-50% duty cycle clock input.

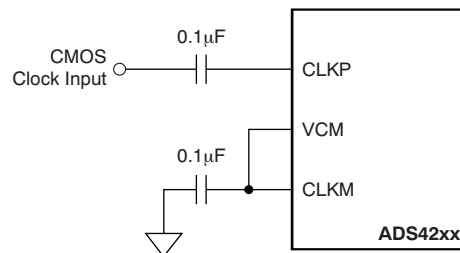

Figure 54. Single-Ended Clock Driving Circuit

8.2 Typical Applications

8.2.1 Analog Input

The analog input consists of a switched-capacitor based, differential sample-and-hold (S/H) architecture. This differential topology results in very good ac performance even for high input frequencies at high sampling rates. The INP and INM terminals must be externally biased around a common-mode voltage of 0.95V, available on the VCM terminal. For a full-scale differential input, each input terminal (INP and INM) must swing symmetrically between $V_{CM} + 0.5V$ and $V_{CM} - 0.5V$, resulting in a $2V_{PP}$ differential input swing. The input sampling circuit has a high 3dB bandwidth that extends up to 550MHz (measured from the input terminals to the sampled voltage). Figure 55 shows an equivalent circuit for the analog input.

Typical Applications (continued)

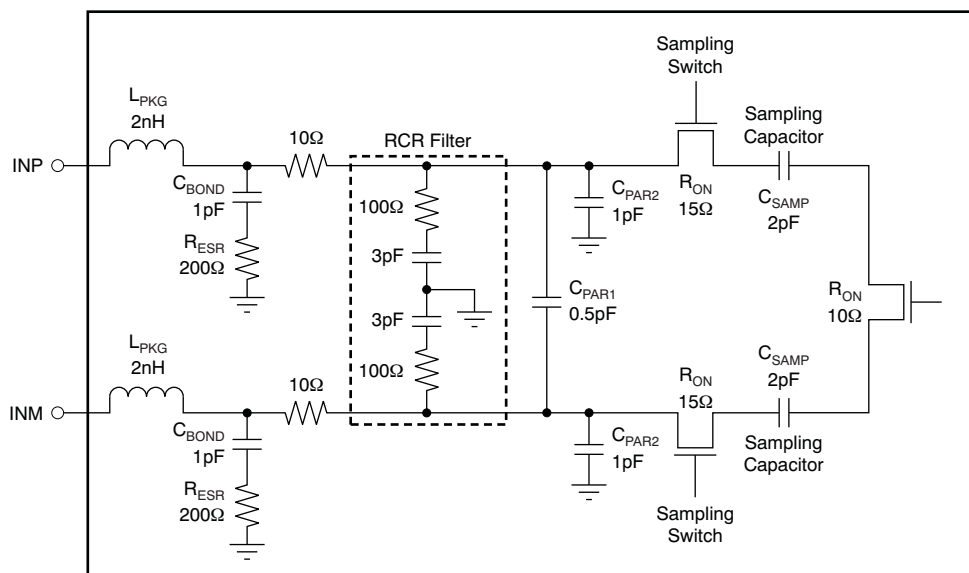

Figure 55. Analog Input Equivalent Circuit

8.2.1.1 Design Requirements for Drive Circuits

For optimum performance, the analog inputs must be driven differentially. This operation improves the common-mode noise immunity and even-order harmonic rejection. A 5Ω to 15Ω resistor in series with each input terminal is recommended to damp out ringing caused by package parasitics.

SFDR performance can be limited as a result of several reasons, including the effects of sampling glitches; nonlinearity of the sampling circuit; and nonlinearity of the quantizer that follows the sampling circuit. Depending on the input frequency, sample rate, and input amplitude, one of these factors plays a dominant part in limiting performance. At very high input frequencies (greater than approximately 300MHz), SFDR is determined largely by the device sampling circuit nonlinearity. At low input amplitudes, the quantizer nonlinearity usually limits performance.

Glitches are caused by the opening and closing of the sampling switches. The driving circuit should present a low source impedance to absorb these glitches. Otherwise, glitches could limit performance, primarily at low input frequencies (up to approximately 200MHz). It is also necessary to present low impedance (less than 50Ω) for the common-mode switching currents. This configuration can be achieved by using two resistors from each input terminated to the common-mode voltage (VCM).

The device includes an internal R-C filter from each input to ground. The purpose of this filter is to absorb the sampling glitches inside the device itself. The cutoff frequency of the R-C filter involves a trade-off. A lower cutoff frequency (larger C) absorbs glitches better, but it reduces the input bandwidth. On the other hand, with a higher cutoff frequency (smaller C), bandwidth support is maximized. However, the sampling glitches now must be supplied by the external drive circuit. This tradeoff has limitations as a result of the presence of the package bond-wire inductance.

In the ADS4245, the R-C component values have been optimized while supporting high input bandwidth (up to 550MHz). However, in applications with input frequencies up to 200MHz to 300MHz, the filtering of the glitches can be improved further using an external R-C-R filter; see [Figure 56](#) and [Figure 57](#).

Typical Applications (continued)

8.2.1.2 Detailed Design Procedure

Two example driving circuit configurations are shown in Figure 56 and Figure 57—one optimized for low bandwidth (low input frequencies) and the other one for high bandwidth to support higher input frequencies. Note that both of the drive circuits have been terminated by 50Ω near the ADC side. The termination is accomplished by a 25Ω resistor from each input to the $1.5V$ common-mode (VCM) from the device. This architecture allows the analog inputs to be biased around the required common-mode voltage.

The mismatch in the transformer parasitic capacitance (between the windings) results in degraded even-order harmonic performance. Connecting two identical RF transformers back-to-back helps minimize this mismatch; good performance is obtained for high-frequency input signals. An additional termination resistor pair may be required between the two transformers, as shown in Figure 56, Figure 57, and Figure 58. The center point of this termination is connected to ground to improve the balance between the P and M sides. The values of the terminations between the transformers and on the secondary side must be chosen to obtain an effective 50Ω (in the case of 50Ω source impedance).

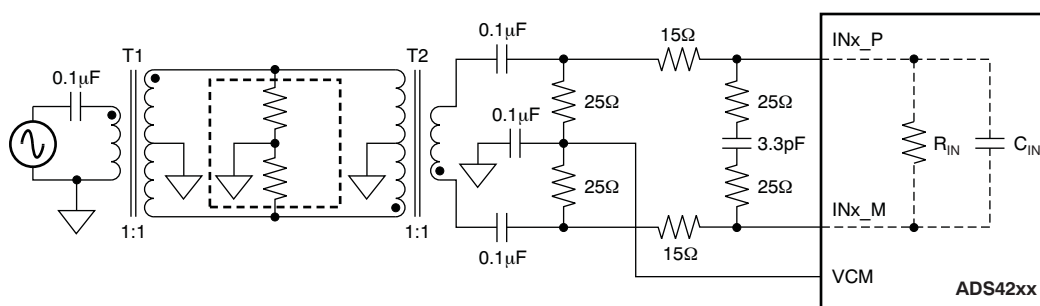

Figure 56. Drive Circuit With Low Bandwidth (For Low Input Frequencies Less Than 150MHz)

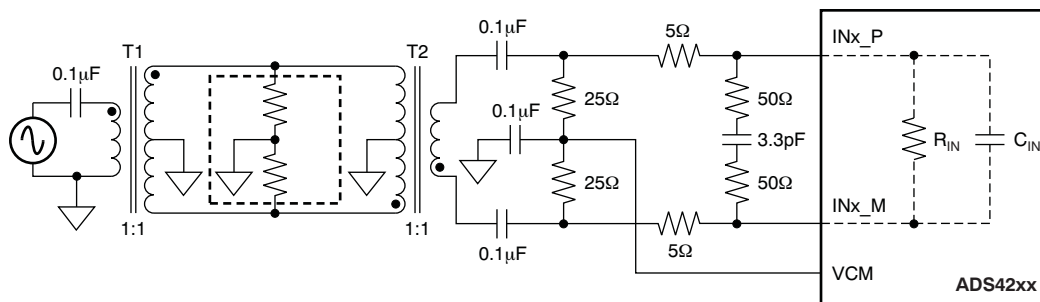

Figure 57. Drive Circuit With High Bandwidth (For High Input Frequencies Greater Than 150MHz And Less Than 270MHz)

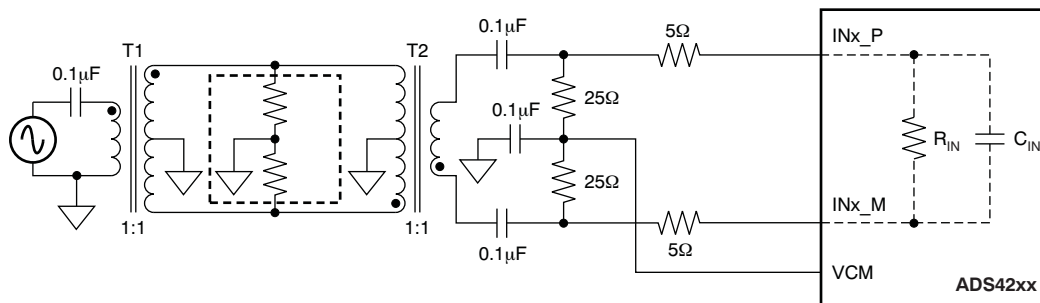

Figure 58. Drive Circuit With Very High Bandwidth (Greater Than 270MHz)

Typical Applications (continued)

All of these examples show 1:1 transformers being used with a 50Ω source. As explained in the [Drive Circuit Requirements](#) section, this configuration helps to present a low source impedance to absorb the sampling glitches. With a 1:4 transformer, the source impedance is 200Ω. The higher source impedance is unable to absorb the sampling glitches effectively and can lead to degradation in performance (compared to using 1:1 transformers).

In almost all cases, either a band-pass or low-pass filter is required to obtain the desired dynamic performance, as shown in [Figure 59](#). Such filters present low source impedance at the high frequencies corresponding to the sampling glitch and help avoid the performance loss with the high source impedance.

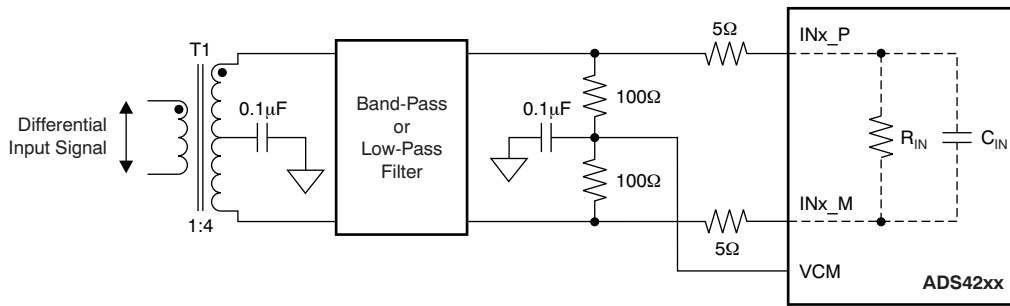
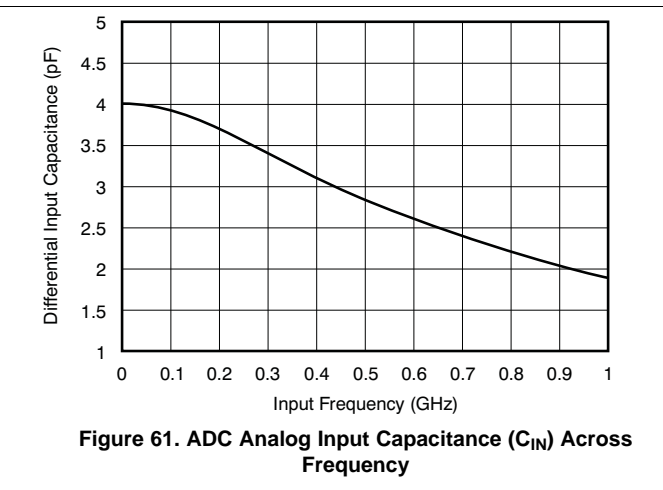
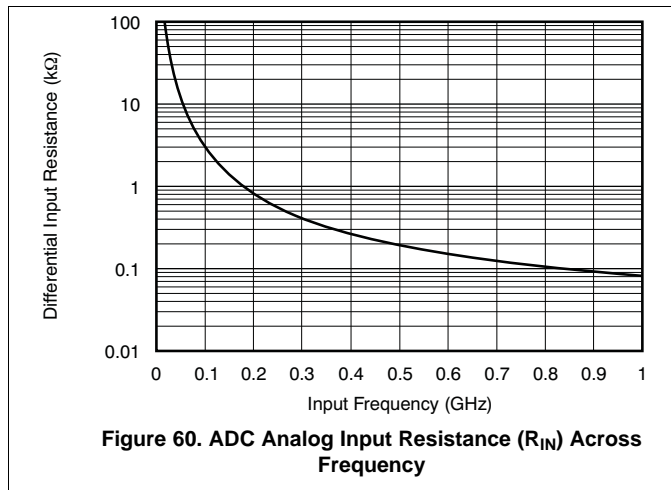

Figure 59. Drive Circuit With A 1:4 Transformer

8.2.1.3 Application Curves

In addition, the drive circuit may have to be designed to provide a low insertion loss over the desired frequency range and matched impedance to the source. Furthermore, the ADC input impedance must be considered. [Figure 60](#) and [Figure 61](#) show the impedance ($Z_{IN} = R_{IN} \parallel C_{IN}$) looking into the ADC input terminals.



9 Power Supply Recommendations

The recommended analog/digital power supply range for ADS4245 is 1.7V to 1.9V.

10 Layout

10.1 Layout Guidelines

10.1.1 Grounding

A single ground plane is sufficient to give good performance, provided the analog, digital, and clock sections of the board are cleanly partitioned. See the [ADS4226 Evaluation Module \(SLAU333\)](#) for details on layout and grounding.

10.1.2 Supply Decoupling

Because the ADS4245 already includes internal decoupling, minimal external decoupling can be used without loss in performance. Note that decoupling capacitors can help filter external power-supply noise; thus, the optimum number of capacitors depends on the actual application. The decoupling capacitors should be placed very close to the converter supply terminals.

10.1.3 Exposed Pad

In addition to providing a path for heat dissipation, the PowerPAD is also electrically connected internally to the digital ground. Therefore, it is necessary to solder the exposed pad to the ground plane for best thermal and electrical performance. For detailed information, see application notes [QFN Layout Guidelines \(SLOA122\)](#) and [QFN/SON PCB Attachment \(SLUA271\)](#).

10.1.4 Routing Analog Inputs

It is advisable to route differential analog input pairs (INP_x and INM_x) close to each other. To minimize the possibility of coupling from a channel analog input to the sampling clock, the analog input pairs of both channels should be routed perpendicular to the sampling clock. See the [ADS4226 Evaluation Module \(SLAU333\)](#) for reference routing.

10.2 Layout Example

Figure 62 shows a snapshot of the PCB layout from the ADS424x EVM.

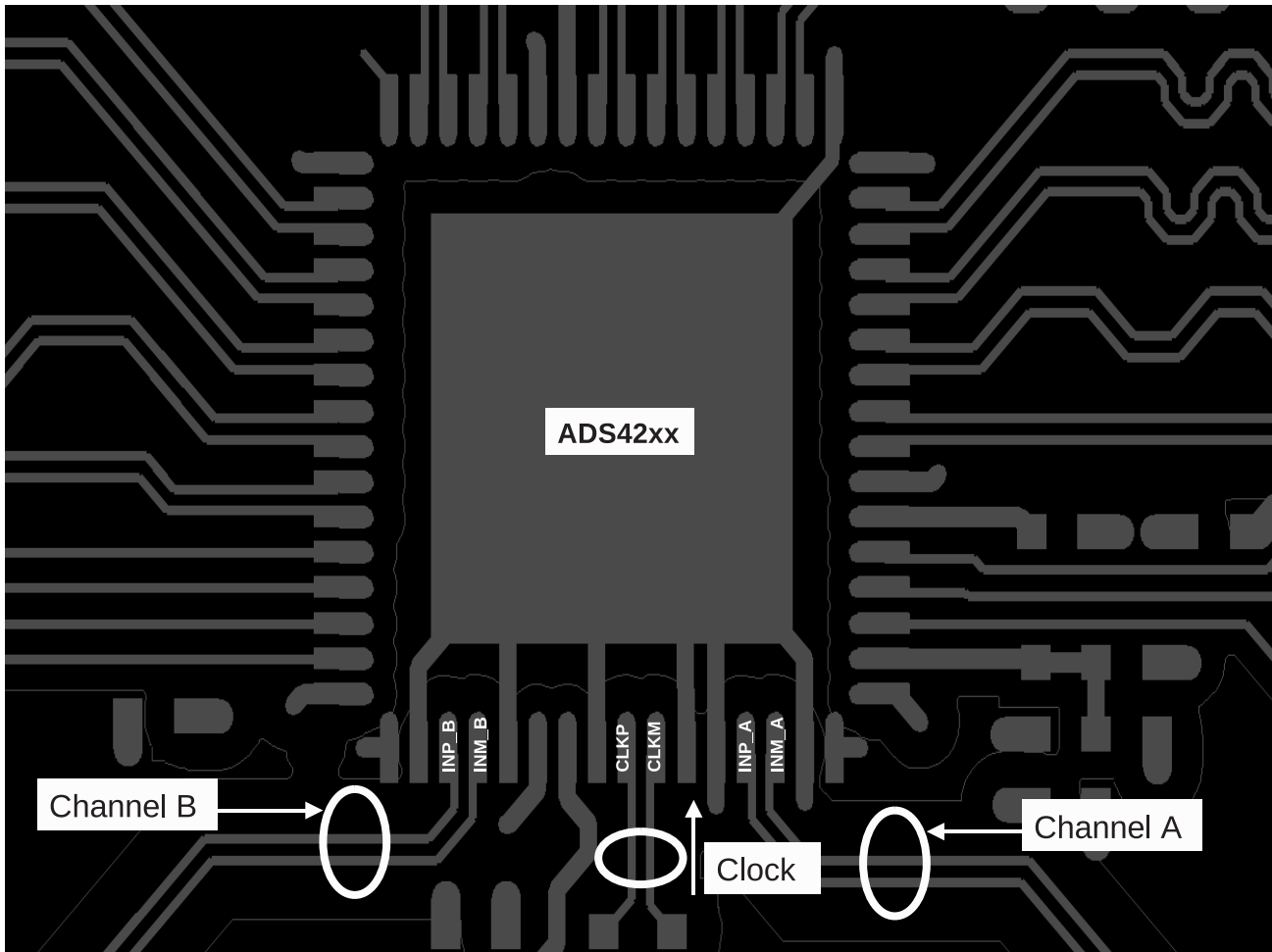

Figure 62. ADS42XX EVM PCB Layout

11 Device and Documentation Support

11.1 Device Support

11.1.1 Device Support

11.1.1.1 Definition Of Specifications

Analog Bandwidth – The analog input frequency at which the power of the fundamental is reduced by 3 dB with respect to the low-frequency value.

Aperture Delay – The delay in time between the rising edge of the input sampling clock and the actual time at which the sampling occurs. This delay is different across channels. The maximum variation is specified as aperture delay variation (channel-to-channel).

Aperture Uncertainty (Jitter) – The sample-to-sample variation in aperture delay.

Clock Pulse Width/Duty Cycle – The duty cycle of a clock signal is the ratio of the time the clock signal remains at a logic high (clock pulse width) to the period of the clock signal. Duty cycle is typically expressed as a percentage. A perfect differential sine-wave clock results in a 50% duty cycle.

Maximum Conversion Rate – The maximum sampling rate at which specified operation is given. All parametric testing is performed at this sampling rate unless otherwise noted.

Minimum Conversion Rate – The minimum sampling rate at which the ADC functions.

Differential Nonlinearity (DNL) – An ideal ADC exhibits code transitions at analog input values spaced exactly 1LSB apart. The DNL is the deviation of any single step from this ideal value, measured in units of LSBs.

Integral Nonlinearity (INL) – The INL is the deviation of the ADC transfer function from a best fit line determined by a least squares curve fit of that transfer function, measured in units of LSBs.

Gain Error – Gain error is the deviation of the ADC actual input full-scale range from its ideal value. The gain error is given as a percentage of the ideal input full-scale range. Gain error has two components: error as a result of reference inaccuracy (E_{GREF}) and error as a result of the channel (E_{GCHAN}). Both errors are specified independently as E_{GREF} and E_{GCHAN} .

To a first-order approximation, the total gain error is $E_{TOTAL} \sim E_{GREF} + E_{GCHAN}$.

For example, if $E_{TOTAL} = \pm 0.5\%$, the full-scale input varies from $(1 - 0.5/100) \times FS_{ideal}$ to $(1 + 0.5/100) \times FS_{ideal}$.

Offset Error – The offset error is the difference, given in number of LSBs, between the ADC actual average idle channel output code and the ideal average idle channel output code. This quantity is often mapped into millivolts.

Temperature Drift – The temperature drift coefficient (with respect to gain error and offset error) specifies the change per degree Celsius of the parameter from T_{MIN} to T_{MAX} . It is calculated by dividing the maximum deviation of the parameter across the T_{MIN} to T_{MAX} range by the difference $T_{MAX} - T_{MIN}$.

Signal-to-Noise Ratio – SNR is the ratio of the power of the fundamental (P_S) to the noise floor power (P_N), excluding the power at dc and the first nine harmonics.

$$SNR = 10 \log_{10} \frac{P_S}{P_N} \quad (1)$$

SNR is either given in units of dBc (dB to carrier) when the absolute power of the fundamental is used as the reference, or dBFS (dB to full-scale) when the power of the fundamental is extrapolated to the converter full-scale range.

Signal-to-Noise and Distortion (SINAD) – SINAD is the ratio of the power of the fundamental (P_S) to the power of all the other spectral components including noise (P_N) and distortion (P_D), but excluding dc.

$$SINAD = 10 \log_{10} \frac{P_S}{P_N + P_D} \quad (2)$$

Device Support (continued)

SINAD is either given in units of dBc (dB to carrier) when the absolute power of the fundamental is used as the reference, or dBFS (dB to full-scale) when the power of the fundamental is extrapolated to the converter full-scale range.

Effective Number of Bits (ENOB) – ENOB is a measure of the converter performance as compared to the theoretical limit based on quantization noise.

$$\text{ENOB} = \frac{\text{SINAD} - 1.76}{6.02} \quad (3)$$

Total Harmonic Distortion (THD) – THD is the ratio of the power of the fundamental (P_S) to the power of the first nine harmonics (P_D).

$$\text{THD} = 10\text{Log}^{10} \frac{P_S}{P_N} \quad (4)$$

THD is typically given in units of dBc (dB to carrier).

Spurious-Free Dynamic Range (SFDR) – The ratio of the power of the fundamental to the highest other spectral component (either spur or harmonic). SFDR is typically given in units of dBc (dB to carrier).

Two-Tone Intermodulation Distortion – IMD3 is the ratio of the power of the fundamental (at frequencies f_1 and f_2) to the power of the worst spectral component at either frequency $2f_1 - f_2$ or $2f_2 - f_1$. IMD3 is either given in units of dBc (dB to carrier) when the absolute power of the fundamental is used as the reference, or dBFS (dB to full-scale) when the power of the fundamental is extrapolated to the converter full-scale range.

DC Power-Supply Rejection Ratio (DC PSRR) – DC PSRR is the ratio of the change in offset error to a change in analog supply voltage. The dc PSRR is typically given in units of mV/V.

AC Power-Supply Rejection Ratio (AC PSRR) – AC PSRR is the measure of rejection of variations in the supply voltage by the ADC. If ΔV_{SUP} is the change in supply voltage and ΔV_{OUT} is the resultant change of the ADC output code (referred to the input), then:

$$\text{PSRR} = 20\text{Log}^{10} \frac{\Delta V_{\text{OUT}}}{\Delta V_{\text{SUP}}} \quad (\text{Expressed in dBc}) \quad (5)$$

Voltage Overload Recovery – The number of clock cycles taken to recover to less than 1% error after an overload on the analog inputs. This is tested by separately applying a sine wave signal with 6 dB positive and negative overload. The deviation of the first few samples after the overload (from the expected values) is noted.

Common-Mode Rejection Ratio (CMRR) – CMRR is the measure of rejection of variation in the analog input common-mode by the ADC. If $\Delta V_{\text{CM_IN}}$ is the change in the common-mode voltage of the input terminals and ΔV_{OUT} is the resulting change of the ADC output code (referred to the input), then:

$$\text{CMRR} = 20\text{Log}^{10} \frac{\Delta V_{\text{OUT}}}{\Delta V_{\text{CM}}} \quad (\text{Expressed in dBc}) \quad (6)$$

Crosstalk (only for multi-channel ADCs) – This is a measure of the internal coupling of a signal from an adjacent channel into the channel of interest. It is specified separately for coupling from the immediate neighboring channel (near-channel) and for coupling from channel across the package (far-channel). It is usually measured by applying a full-scale signal in the adjacent channel. Crosstalk is the ratio of the power of the coupling signal (as measured at the output of the channel of interest) to the power of the signal applied at the adjacent channel input. It is typically expressed in dBc.

11.2 Receiving Notification of Documentation Updates

To receive notification of documentation updates, navigate to the device product folder on ti.com. In the upper right corner, click on *Alert me* to register and receive a weekly digest of any product information that has changed. For change details, review the revision history included in any revised document.

11.3 Community Resources

The following links connect to TI community resources. Linked contents are provided "AS IS" by the respective contributors. They do not constitute TI specifications and do not necessarily reflect TI's views; see TI's [Terms of Use](#).

TI E2E™ Online Community *TI's Engineer-to-Engineer (E2E) Community*. Created to foster collaboration among engineers. At e2e.ti.com, you can ask questions, share knowledge, explore ideas and help solve problems with fellow engineers.

Design Support *TI's Design Support* Quickly find helpful E2E forums along with design support tools and contact information for technical support.

11.4 Trademarks

PowerPAD, E2E are trademarks of Texas Instruments.
PowerPAD is a trademark of Texas Instruments Incorporated.
All other trademarks are the property of their respective owners.

11.5 Electrostatic Discharge Caution



This integrated circuit can be damaged by ESD. Texas Instruments recommends that all integrated circuits be handled with appropriate precautions. Failure to observe proper handling and installation procedures can cause damage.

ESD damage can range from subtle performance degradation to complete device failure. Precision integrated circuits may be more susceptible to damage because very small parametric changes could cause the device not to meet its published specifications.

11.6 Glossary

[SLYZ022](#) — *TI Glossary*.

This glossary lists and explains terms, acronyms, and definitions.

12 Mechanical, Packaging, and Orderable Information

The following pages include mechanical, packaging, and orderable information. This information is the most current data available for the designated devices. This data is subject to change without notice and revision of this document. For browser-based versions of this data sheet, refer to the left-hand navigation.

PACKAGING INFORMATION

| Orderable Device | Status (1) | Package Type | Package Drawing | Pins | Package Qty | Eco Plan (2) | Lead/Ball Finish (6) | MSL Peak Temp (3) | Op Temp (°C) | Device Marking (4/5) | Samples |
|------------------|---------------|--------------|-----------------|------|-------------|-------------------------|-------------------------|----------------------|--------------|-------------------------|-------------------------|
| ADS4245MRGC25EP | ACTIVE | VQFN | RGC | 64 | 250 | Green (RoHS & no Sb/Br) | NIPDAU | Level-3-260C-168 HR | -55 to 125 | AZ4245EP | Samples |
| V62/14609-01XE | ACTIVE | VQFN | RGC | 64 | 250 | Green (RoHS & no Sb/Br) | NIPDAU | Level-3-260C-168 HR | -55 to 125 | AZ4245EP | Samples |

(1) The marketing status values are defined as follows:

ACTIVE: Product device recommended for new designs.

LIFEBUY: TI has announced that the device will be discontinued, and a lifetime-buy period is in effect.

NRND: Not recommended for new designs. Device is in production to support existing customers, but TI does not recommend using this part in a new design.

PREVIEW: Device has been announced but is not in production. Samples may or may not be available.

OBsolete: TI has discontinued the production of the device.

(2) **RoHS:** TI defines "RoHS" to mean semiconductor products that are compliant with the current EU RoHS requirements for all 10 RoHS substances, including the requirement that RoHS substance do not exceed 0.1% by weight in homogeneous materials. Where designed to be soldered at high temperatures, "RoHS" products are suitable for use in specified lead-free processes. TI may reference these types of products as "Pb-Free".

RoHS Exempt: TI defines "RoHS Exempt" to mean products that contain lead but are compliant with EU RoHS pursuant to a specific EU RoHS exemption.

Green: TI defines "Green" to mean the content of Chlorine (Cl) and Bromine (Br) based flame retardants meet JS709B low halogen requirements of <=1000ppm threshold. Antimony trioxide based flame retardants must also meet the <=1000ppm threshold requirement.

(3) MSL, Peak Temp. - The Moisture Sensitivity Level rating according to the JEDEC industry standard classifications, and peak solder temperature.

(4) There may be additional marking, which relates to the logo, the lot trace code information, or the environmental category on the device.

(5) Multiple Device Markings will be inside parentheses. Only one Device Marking contained in parentheses and separated by a "~" will appear on a device. If a line is indented then it is a continuation of the previous line and the two combined represent the entire Device Marking for that device.

(6) Lead/Ball Finish - Orderable Devices may have multiple material finish options. Finish options are separated by a vertical ruled line. Lead/Ball Finish values may wrap to two lines if the finish value exceeds the maximum column width.

Important Information and Disclaimer:The information provided on this page represents TI's knowledge and belief as of the date that it is provided. TI bases its knowledge and belief on information provided by third parties, and makes no representation or warranty as to the accuracy of such information. Efforts are underway to better integrate information from third parties. TI has taken and continues to take reasonable steps to provide representative and accurate information but may not have conducted destructive testing or chemical analysis on incoming materials and chemicals. TI and TI suppliers consider certain information to be proprietary, and thus CAS numbers and other limited information may not be available for release.

In no event shall TI's liability arising out of such information exceed the total purchase price of the TI part(s) at issue in this document sold by TI to Customer on an annual basis.

OTHER QUALIFIED VERSIONS OF ADS4245-EP :

- Catalog: [ADS4245](#)

NOTE: Qualified Version Definitions:

- Catalog - TI's standard catalog product

TAPE AND REEL INFORMATION



QUADRANT ASSIGNMENTS FOR PIN 1 ORIENTATION IN TAPE



*All dimensions are nominal

| Device | Package Type | Package Drawing | Pins | SPQ | Reel Diameter (mm) | Reel Width W1 (mm) | A0 (mm) | B0 (mm) | K0 (mm) | P1 (mm) | W (mm) | Pin1 Quadrant |
|-----------------|--------------|-----------------|------|-----|--------------------|--------------------|---------|---------|---------|---------|--------|---------------|
| ADS4245MRGC25EP | VQFN | RGC | 64 | 250 | 180.0 | 16.4 | 9.3 | 9.3 | 1.5 | 12.0 | 16.0 | Q2 |

TAPE AND REEL BOX DIMENSIONS



*All dimensions are nominal

| Device | Package Type | Package Drawing | Pins | SPQ | Length (mm) | Width (mm) | Height (mm) |
|-----------------|--------------|-----------------|------|-----|-------------|------------|-------------|
| ADS4245MRGC25EP | VQFN | RGC | 64 | 250 | 213.0 | 191.0 | 55.0 |

GENERIC PACKAGE VIEW

RGC 64

VQFN - 1 mm max height

9 x 9, 0.5 mm pitch

PLASTIC QUAD FLATPACK - NO LEAD

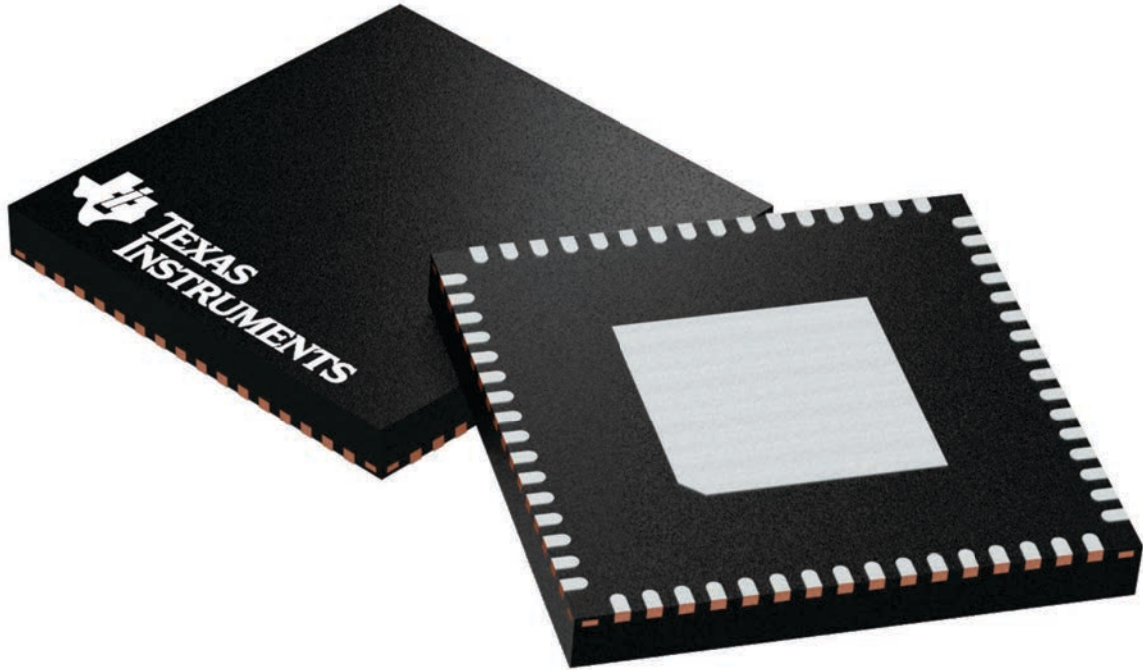

Images above are just a representation of the package family, actual package may vary.
Refer to the product data sheet for package details.

4224597/A

RGC0064H

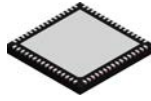

PACKAGE OUTLINE

VQFN - 1 mm max height

PLASTIC QUAD FLATPACK - NO LEAD

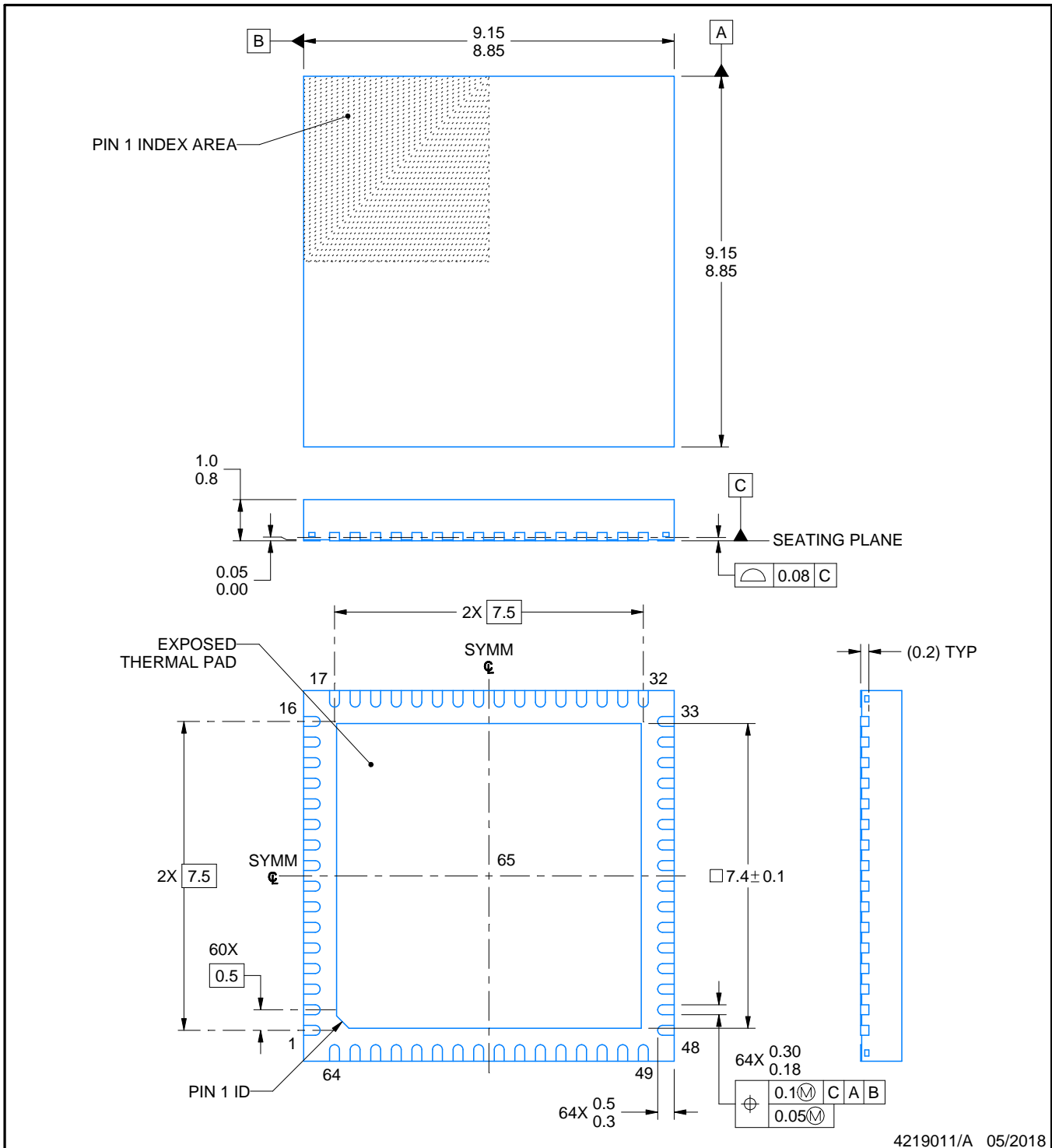

NOTES:

1. All linear dimensions are in millimeters. Any dimensions in parenthesis are for reference only. Dimensioning and tolerancing per ASME Y14.5M.
2. This drawing is subject to change without notice.
3. The package thermal pad must be soldered to the printed circuit board for thermal and mechanical performance.

EXAMPLE BOARD LAYOUT

RGC0064H

VQFN - 1 mm max height

PLASTIC QUAD FLATPACK - NO LEAD

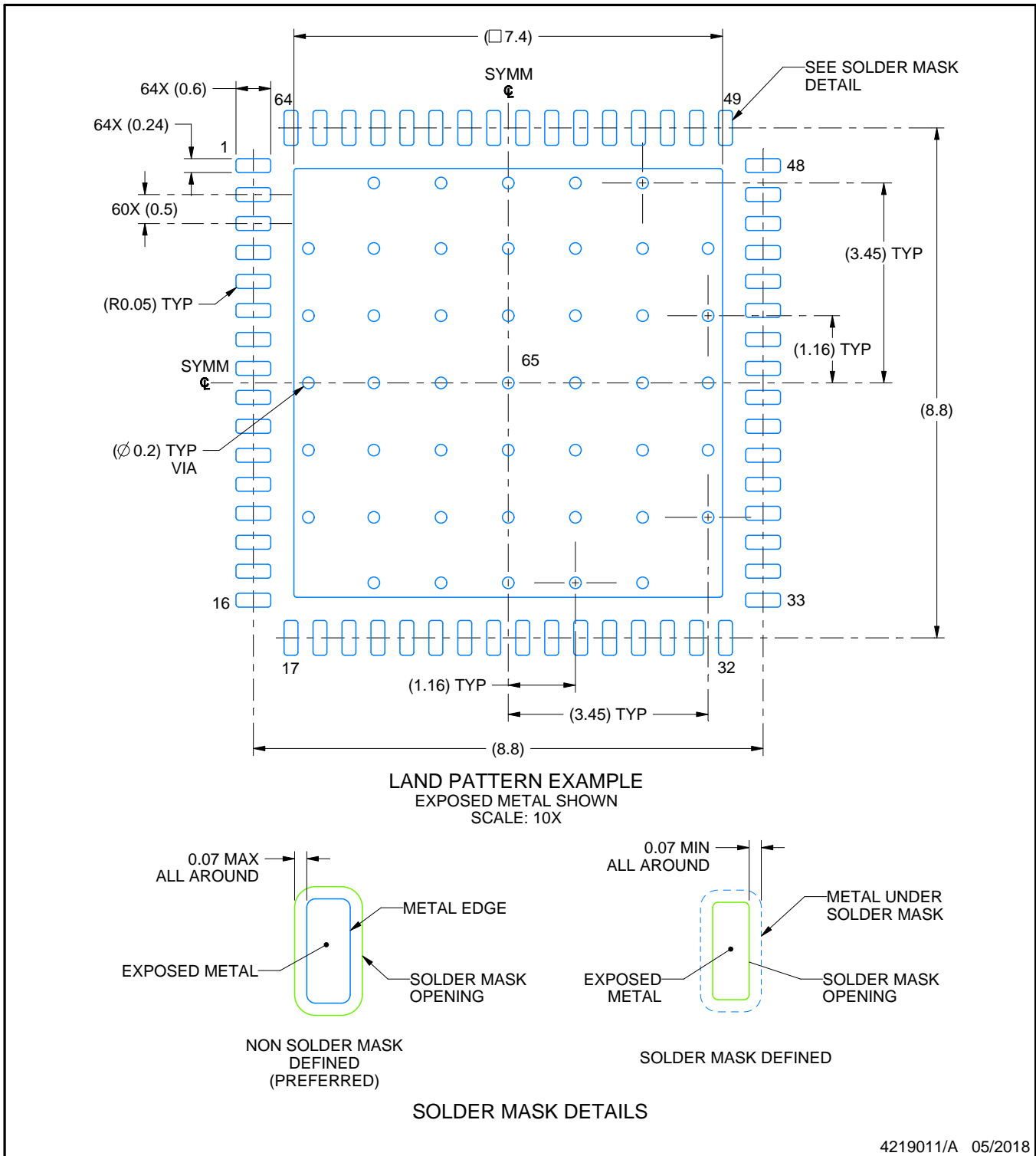

NOTES: (continued)

4. This package is designed to be soldered to a thermal pad on the board. For more information, see Texas Instruments literature number SLUA271 (www.ti.com/lit/sluea271).
5. Vias are optional depending on application, refer to device data sheet. If any vias are implemented, refer to their locations shown on this view. It is recommended that vias under paste be filled, plugged or tented.

EXAMPLE STENCIL DESIGN

RGC0064H

VQFN - 1 mm max height

PLASTIC QUAD FLATPACK - NO LEAD

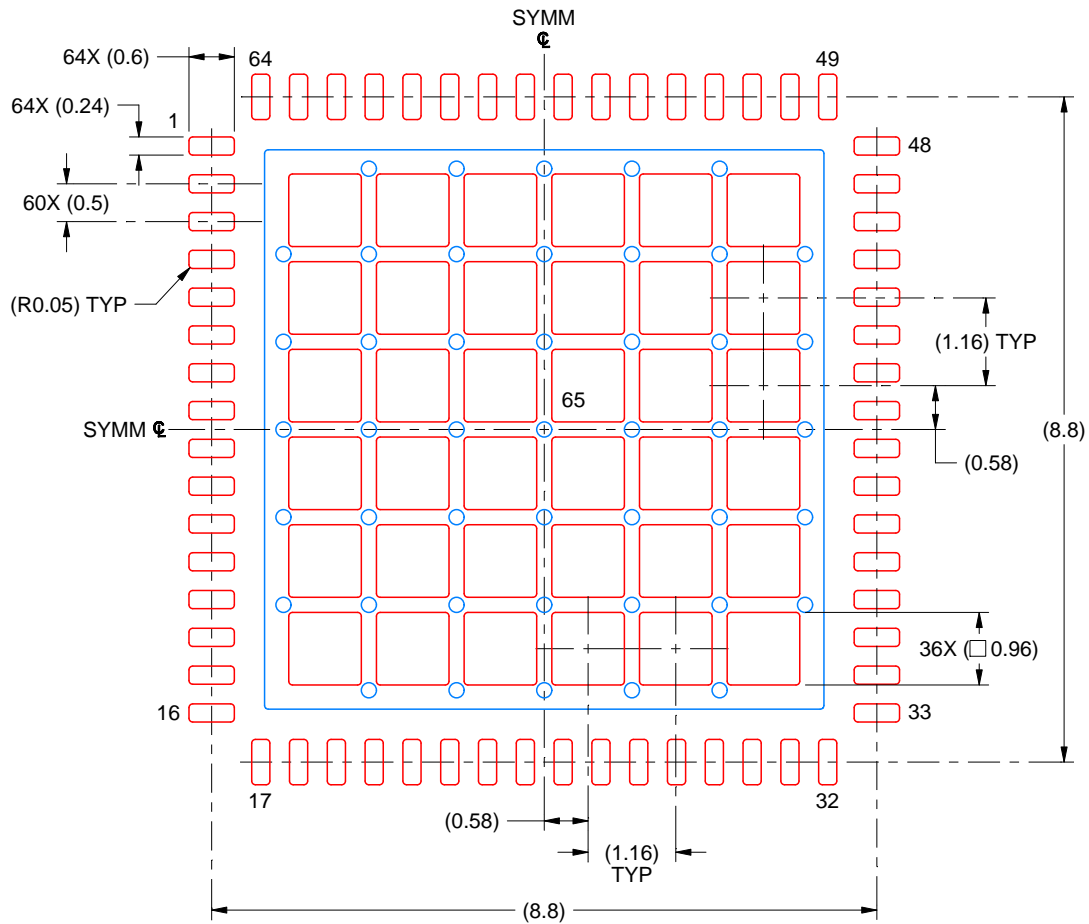

SOLDER PASTE EXAMPLE
 BASED ON 0.125 MM THICK STENCIL
 SCALE: 10X

EXPOSED PAD 65
 61% PRINTED SOLDER COVERAGE BY AREA UNDER PACKAGE

4219011/A 05/2018

NOTES: (continued)

6. Laser cutting apertures with trapezoidal walls and rounded corners may offer better paste release. IPC-7525 may have alternate design recommendations.

IMPORTANT NOTICE AND DISCLAIMER

TI PROVIDES TECHNICAL AND RELIABILITY DATA (INCLUDING DATASHEETS), DESIGN RESOURCES (INCLUDING REFERENCE DESIGNS), APPLICATION OR OTHER DESIGN ADVICE, WEB TOOLS, SAFETY INFORMATION, AND OTHER RESOURCES "AS IS" AND WITH ALL FAULTS, AND DISCLAIMS ALL WARRANTIES, EXPRESS AND IMPLIED, INCLUDING WITHOUT LIMITATION ANY IMPLIED WARRANTIES OF MERCHANTABILITY, FITNESS FOR A PARTICULAR PURPOSE OR NON-INFRINGEMENT OF THIRD PARTY INTELLECTUAL PROPERTY RIGHTS.

These resources are intended for skilled developers designing with TI products. You are solely responsible for (1) selecting the appropriate TI products for your application, (2) designing, validating and testing your application, and (3) ensuring your application meets applicable standards, and any other safety, security, or other requirements. These resources are subject to change without notice. TI grants you permission to use these resources only for development of an application that uses the TI products described in the resource. Other reproduction and display of these resources is prohibited. No license is granted to any other TI intellectual property right or to any third party intellectual property right. TI disclaims responsibility for, and you will fully indemnify TI and its representatives against, any claims, damages, costs, losses, and liabilities arising out of your use of these resources.

TI's products are provided subject to TI's Terms of Sale (www.ti.com/legal/termsofsale.html) or other applicable terms available either on ti.com or provided in conjunction with such TI products. TI's provision of these resources does not expand or otherwise alter TI's applicable warranties or warranty disclaimers for TI products.

Mailing Address: Texas Instruments, Post Office Box 655303, Dallas, Texas 75265
Copyright © 2020, Texas Instruments Incorporated