



ADSD-1410S

Dual 14-Bit, 10MSPS Sampling A/D Converter

FEATURES

- 14-bit resolution; 10MSPS sampling rate
- Functionally complete; $\pm 2.5V$ input range
- No missing codes over full temperature range
- Edge-triggered
- $\pm 5V$ supplies, 1.6 Watts
- 76dB SNR, $-83dB$ THD
- Ideal for both time and frequency domain applications

GENERAL DESCRIPTION

The ADSD-1410S is a functionally complete, dual 14-bit, 10MSPS, sampling A/D converter. Its standard, 40-pin, triple-wide SMT DIP contains two fast-settling sample/hold amplifiers, two 14-bit A/D converters, multiplexed output buffers, a precision reference, and all the timing and control logic necessary to operate from either two or a single start convert pulse.

The ADSD-1410S is optimized for wideband frequency-domain applications and is fully FFT tested. The ADSD-1410S requires only $\pm 5V$ supplies and typically consumes 1.6 Watts. The digital output power supply is capable of directly driving 5V or 3V logic systems. Models are available in either commercial 0 to $+70^{\circ}C$ or military -55 to $+125^{\circ}C$ operating temperature ranges.

INPUT/OUTPUT CONNECTIONS

PIN	FUNCTION	PIN	FUNCTION
1	INPUT A	40	INPUT B
2	+5VA	39	+5VA
3	ANALOG GROUND	38	ANALOG GROUND
4	N.C.	37	N.C.
5	OFFSET A	36	OFFSET B
6	RANGE	35	N.C.
7	1.6V REF	34	\overline{EOC} A
8	ANALOG GROUND	33	ANALOG GROUND
9	-5V	32	-5V
10	ENABLE A	31	ENABLE B
11	START A	30	START B
12	VDD	29	\overline{EOC} B
13	BIT 14 (LSB)	28	BIT 1 (MSB)
14	BIT 13	27	BIT 2
15	BIT 12	26	BIT 3
16	BIT 11	25	BIT 4
17	BIT 10	24	BIT 5
18	BIT 9	23	BIT 6
19	BIT 8	22	BIT 7
20	DGND	21	DGND

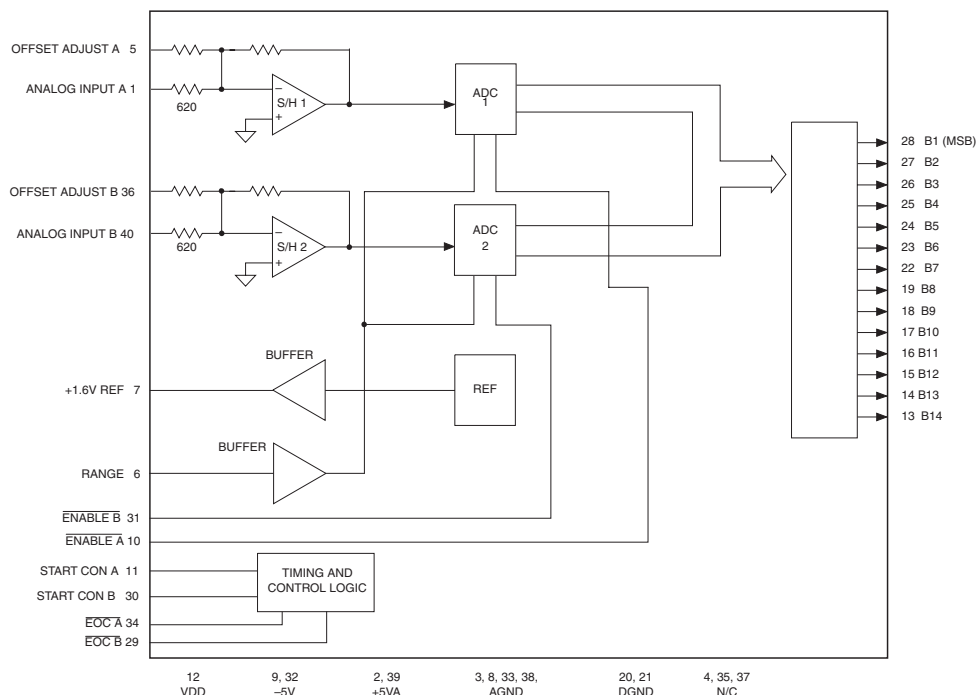

Figure 1. ADSD-1410S Functional Block Diagram

ABSOLUTE MAXIMUM RATINGS

PARAMETERS	LIMITS	UNITS
+5Vcc Supply (Pins 2, 39)	0 to +6	Volts
-5VEE Supply (Pins 9, 32)	0 to -6	Volts
VDD Supply (Pin 12)	-0.3 to (Vcc +0.3)	Volts
Digital Inputs (Pins 10, 11, 30, 31)	-0.3 to (VDD +0.3)	Volts
Analog Input (Pins 1, 40)	±7	Volts
Lead Temp. (10 seconds)	+300	°C

FUNCTIONAL SPECIFICATIONS

(TA = +25°C, VCC = +5V, VDD = +5V, VEE = -5V, 10MSPS sampling rate, Vin = ±2.5V and a minimum 7 minute warmup unless otherwise specified.)

ANALOG INPUTS	MIN.	TYP.	MAX.	UNITS
Input Voltage Range	—	±2.5V	—	Volts
Input Impedence	610	620	630	Ω
Input Capacitance	—	7	15	pF
DIGITAL INPUTS				
Logic Levels				
Logic "1"	+2.4	—	—	Volts
Logic "0"	—	—	+0.8	Volts
Logic Loading "1"	—	—	+10	μA
Logic Loading "0"	—	—	-10	μA
PERFORMANCE				
Integral Non-Linearity				
+25°C (fin=10kHz)	—	±1	—	LSB
0 to +70°C	—	±1	—	LSB
-55 to +125°C	—	±2	—	LSB
Differential Non-Linearity				
(fin = 10kHz)				
+25°C	-0.99	±0.5	+1.5	LSB
0 to +70°C	-0.99	±0.5	+1.5	LSB
-55 to +125°C	-0.99	±0.75	+1.75	LSB
Offset Error				
+25°C (see Figure 3)	—	±0.25	±0.5	%FSR
0 to +70°C	—	±0.25	±0.5	%FSR
-55 to +125°C	—	±0.5	±0.8	%FSR
Gain Error				
+25°C (see Figure 3)	—	±0.3	±0.6	%FSR
0 to +70°C	—	±0.3	±0.6	%FSR
-55 to +125°C	—	±0.6	±0.8	%FSR
No Missing Codes				
14 Bits	-55 to +125°C			
Resolution	14 Bits			
OUTPUTS				
Output Coding	Offset Bin.			
Logic Level				
Logic "1"	VDD = +5V	+3.8	—	—
	VDD = +3.3V	+2.48	—	—
Logic "0"	VDD = +5V	—	—	+0.5
	VDD = +3.3V	—	—	+0.5
Logic Loading "1"	VDD = +5V	—	—	-8
	VDD = +3.3V	—	—	-4
Logic Loading "0"	VDD = +5V	—	—	+8
	VDD = +3.3V	—	—	+4
Internal Reference				
Voltage, +25°C		+1.5	+1.6	+1.7
0 to +70°C		+1.5	+1.6	+1.7
External Current		—	—	5

DYNAMIC PERFORMANCE	MIN.	TYP.	MAX.	UNITS
Total Harm. Distort. (-0.5dB)				
dc to 500kHz	—	-84	-80	dB
500kHz to 5MHz	—	-83	-77	dB
Signal-to-Noise Ratio				
(w/o distortion, -0.5dB)				
dc to 500kHz	74	76	—	dB
500kHz to 5MHz	74	76	—	dB
Signal-to-Noise Ratio				
(and distortion, -0.5dB)				
dc to 500kHz	72	75	—	dB
500kHz to 5MHz	72	75	—	dB
Spurious Free Dyn. Range ①				
dc to 500kHz	—	-87	-82	dB
500kHz to 5MHz	—	-86	-80	dB
Two-tone IMD				
Distortion (fin = 4.85MHz,				
fs = 10MHz, -0.5dB)	—	-80	—	dB
Input Bandwidth (-3dB)				
Small Signal (-20dB input)	—	14	—	MHz
Large Signal (-0.5dB input)	—	14	—	MHz
Aperture Delay Time	—	—	±10	ns
Aperture Uncertainty	—	—	5	ps
S/H Acq. Time, (to ±0.003%FSR)				
Step input	—	—	25	ns
Feedthrough Rejection				
(fin = 5MHz)	—	85	—	dB
Noise	—	250	—	μVrms

TIMING SPECIFICATIONS				
Conversion Rate	1	—	10	MHz
Start Convert High	25	50	500	ns
Start Convert Low	25	50	500	ns
Start Convert to EOC				
Delay	2	6	10	ns
EOC to Data Valid				
Delay	0	7	12	ns
Output Enable Delay	1	6	13	ns
Output Disable Delay	1	6	13	ns

POWER REQUIREMENTS				
Power Supply Ranges				
-5VEE Supply	-5.25	-5.0	-4.75	Volts
+5Vcc Supply	+4.75	+5.0	+5.25	Volts
VDD Supply	+3.0	+5.0	Vcc	Volts
Power Supply Currents				
-5VEE Supply	-100	-89	—	mA
+5Vcc Supply	—	+230	+245	mA
VDD Supply	—	+2.0	+5.0	mA
Power Dissipation	—	1.6	1.7	Watts
Power Supply Rejection	—	—	±0.01	%FSR%V

PHYSICAL/ENVIRONMENTAL				
Oper. Temp. Range, Ambient				
ADSD-1410S	0	—	+70	°C
ADSD-1410S-EX	-55	—	+125	°C
Storage Temperature Range	-65	—	+150	°C
Package Type	40-pin, SMT TDIP			

Footnote:

① Same specification as In-Band Harmonics and Peak Harmonics.

TECHNICAL NOTES

- Rated performance requires using good high-frequency circuit board layout techniques. Connect the digital and analog grounds to one point, the analog ground plane beneath the converter. Due to the inductance and resistance of the power supply return paths, return the analog and digital ground separately to the power supplies.

CALIBRATION PROCEDURE

- Connect the converter per Figure 3. Apply a pulse of 50 nanoseconds typical to START CONVERT (pin 11) at a rate of 2MHz. This rate is chosen to reduce flicker if LED's are used on the outputs for calibration purposes.
- Zero (Offset) Adjustments**
Apply a precision voltage reference source between ANALOG INPUT A (pin 1) and SIGNAL GROUND (pin 3), then adjust the reference source output per Table 2. Adjust trimpot R1 until the code flickers equally between 10 0000 0000 0000 and 10 0000 0000 0001.
- Repeat above step for Analog Input B (Pin 40). Use trimpot R2 for the zero (Offset) adjustment .

Table 2. Offset Adjustment

Input Range	Offset Adjust +1/2 LSB
±2.5V	+0.000153V

Table 3. Output Coding

OUTPUT CODING		INPUT RANGE ±2.5V	BIPOLAR SCALE
MSB	LSB		
11	1111 1111 1111	+2.499695	+FS – 1LSB
11	1000 0000 0000	+1.875000	+3/4FS
11	0000 0000 0000	+1.250000	+1/2FS
10	0000 0000 0000	±0.000000	0
01	0000 0000 0000	-1.250000	-1/2FS
00	1000 0000 0000	-1.875000	-3/4FS
00	0000 0000 0001	-2.499695	-FS+1LSB
00	0000 0000 0000	-2.500000	-FS

- To confirm proper operation of the device, vary the precision reference voltage source to obtain the output coding listed in Table 3.

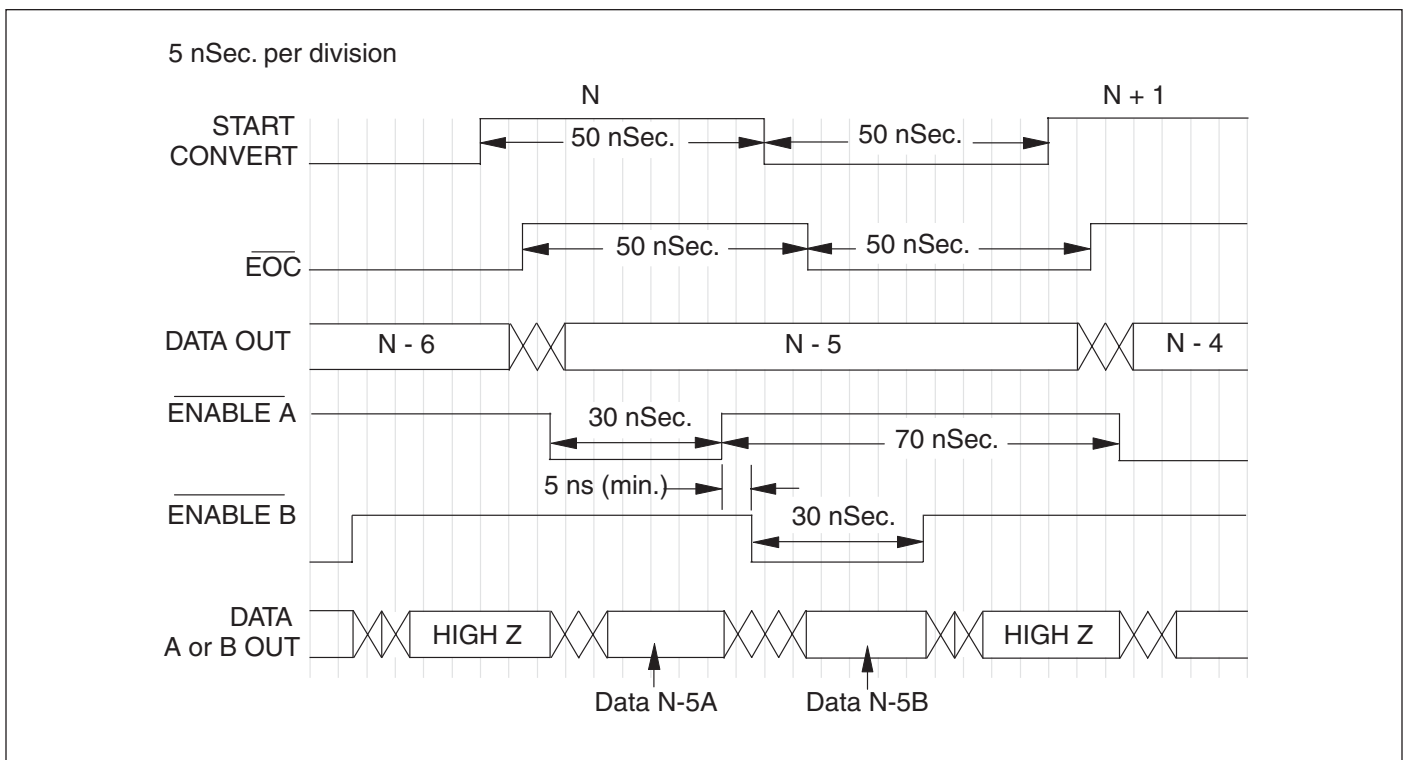

Figure 2. ADSD-1410S Timing Diagram

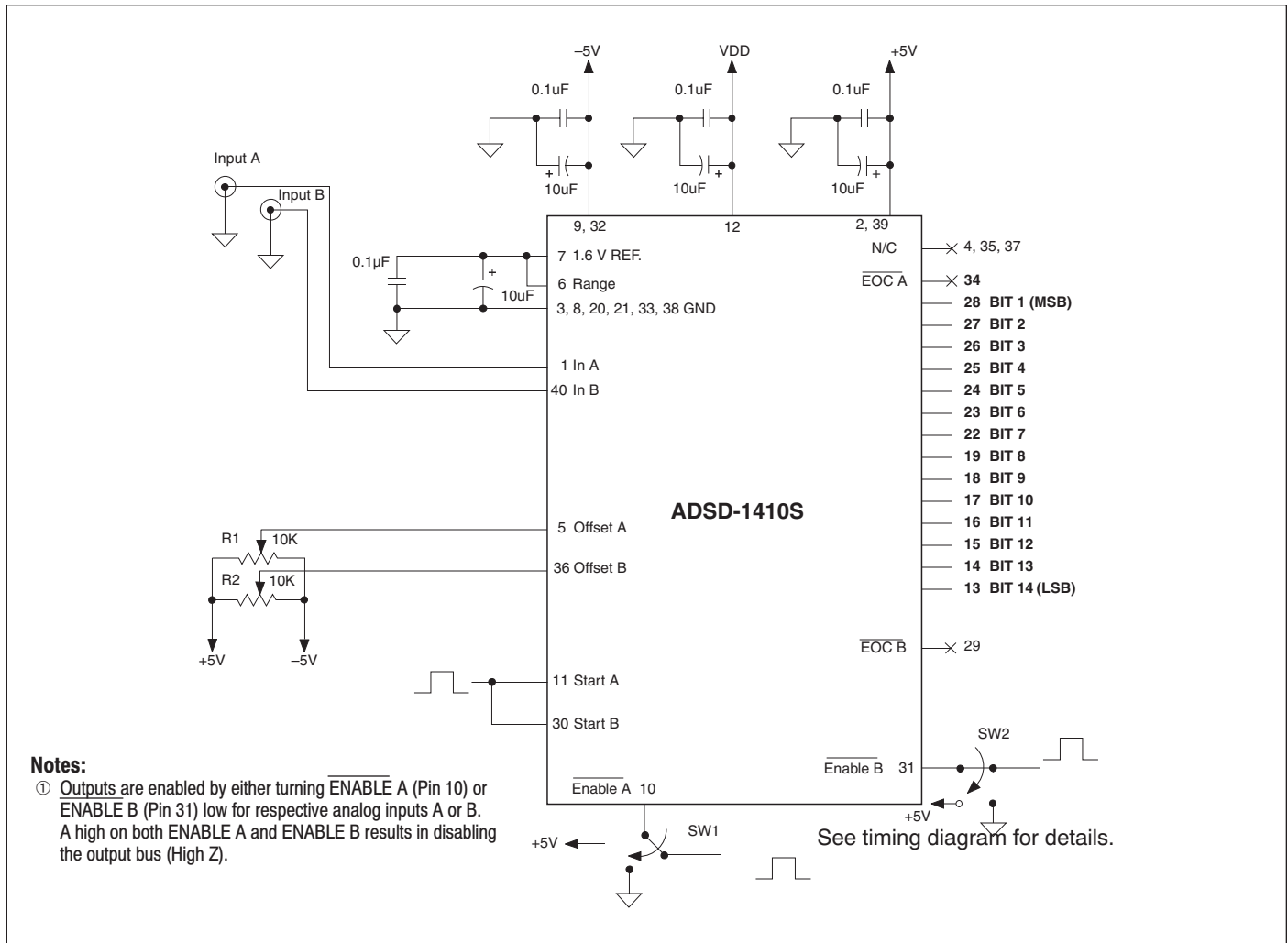

Figure 3. ADSD-1410S Connection Diagram

THERMAL REQUIREMENTS

The ADSD-1410S sampling A/D converter is fully characterized and specified over the commercial operating temperature (ambient) range of 0 to +70°C and military temperature range of -55 to +125°C (EX suffix). All room-temperature (T_A = +25°C) production testing is performed without the use of heat sinks or forced-air cooling. Thermal impedance figures for each device are listed in their respective specification tables.

These devices do not normally require heat sinks, however, standard precautionary design and layout procedures should

be used to ensure devices do not overheat. The ground and power planes beneath the package, as well as all pcb signal runs to and from the device, should be as heavy as possible to help conduct heat away from the package. Electrically-insulating, thermally-conductive "pads" may be installed underneath the package. Minimal air flow over the surface can greatly help reduce the package temperature.

MECHANICAL DIMENSIONS INCHES (mm)

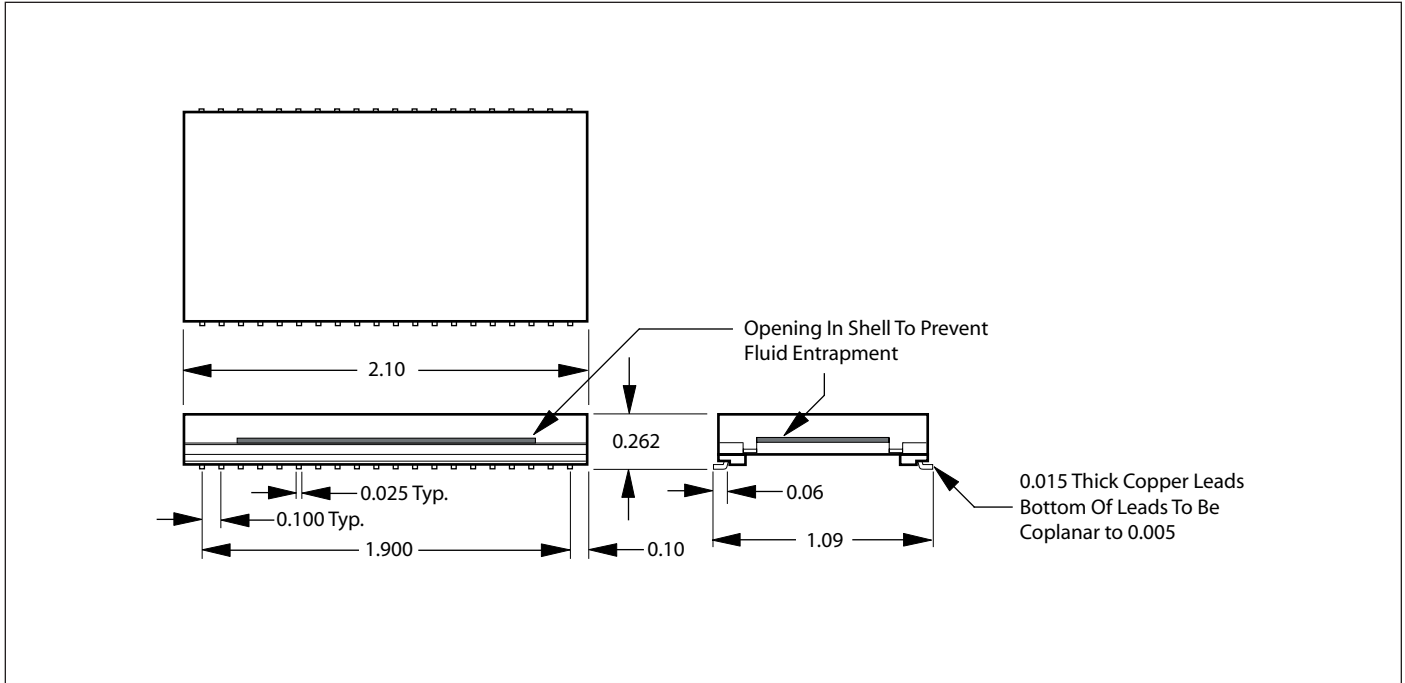

ORDERING INFORMATION

MODEL NUMBER	OPERATING TEMP. RANGE
ADSD-1410S	0 to +70°C
ADSD-1410S-EX	-55 to +125°C

Contact C&D Technologies (Datel) for high-reliability versions



C&D Technologies (DATEL), Inc.
 11 Cabot Boulevard, Mansfield, MA 02048-1151
 Tel: 508.339.3000, 800.233.2765 Fax: 508.339.6356
www.cd4power.com E-mail: sales@cdtechno.com

ISO 9001:2000 REGISTERED

DS-0559A 06/06

C&D Technologies (NCL), Ltd. Milton Keynes, England
 Tel: +44 (0) 1908.615232 E-mail: mk@cdtechno.com

C&D Technologies (DATEL) S.a.r.l. Montigny Le Bretonneux, France
 Tel: +33 (0) 1.34.60.01.01 E-mail: france@cdtechno.com

C&D Technologies (DATEL) GmbH München, Germany
 Tel: +49 (0) 89.544334.0 E-mail: munich@cdtechno.com

C&D Technologies KK Tokyo and Osaka, Japan
 Tel: +81 3.3779.1031, 6.6354.2025 E-mail: tokyo@cdtechno.com, osaka@cdtechno.com

C&D Technologies (DATEL) China Shanghai, People's Republic of China
 Tel: +86.50273678 E-mail: shanghai@cdtechno.com

DATEL makes no representation that the use of its products in the circuits described herein, or the use of other technical information contained herein, will not infringe upon existing or future patent rights. The descriptions contained herein do not imply the granting of licenses to make, use, or sell equipment constructed in accordance therewith. Specifications are subject to change without notice. The DATEL logo is a registered DATEL, Inc. trademark.