

# High Accuracy High Power LED Driver

# ADT6752

## General Description

The ADT6752 is a step-down converter designed for driving high power LEDs. It operates wide input supply voltage range from 6V to 60V with 1A continuous output current. By using current mode control, it has excellent 1.5% output current accuracy and 96% high efficiency. With enhanced protection functions, ADT6752 operates safely against abnormal circumstance.

The ADT6752 is available in small outline eSOP8L (with exposed pad) package.

## Features

- Wide input voltage range : 6V to 60V
- Continuous output current : 1A
- Up to 96% high efficiency
- Excellent  $\pm 1.5\%$  output current accuracy
- Current precision :  $\pm 3\%$
- Multiple protection supported  
(Thermal, OCP, UVLO, Soft-start,  
LED open protection)
- 300kHz fixed frequency
- Integrated jitter function for EMI

## Applications

- High power LED lighting
- Area, Street lamp, MR16 etc.
- Automotive and Marine Lighting
- Architecture Lighting
- Appliances interior lighting

## Typical Application Circuit

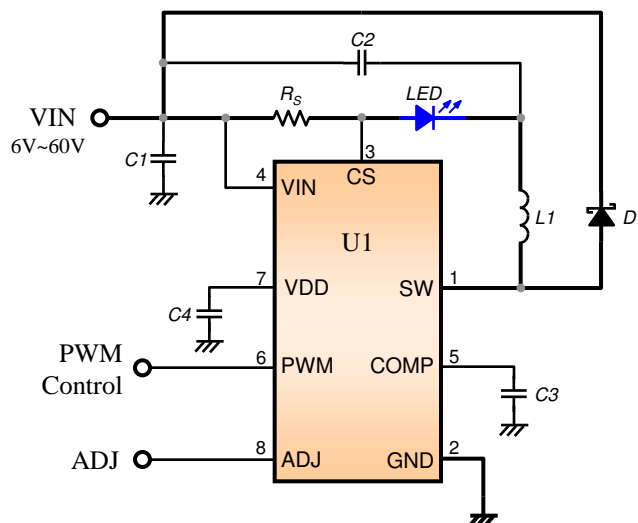

Figure 1. Typical Application Circuit

\* This specifications are subject to be changed without notice

## Part List

Component	Value	Description	Size	Part No.	MFR
U1	-	IC, 1A/60V, LED driver	eSOP8	ADT6752	ADTech
D1	-	Schottky Barrier Diode (2A, 100V)	3216	SSCD210H	ZOWIE
L1	68uH	Inductor, SMD, 1.5A, 220mΩ	12x12x5	PIC1204-680	EROCORE
C1	10uF	Capacitor, Electrolytic, 100V, X7R, 20%	6.3x6.3x8	NACEW100M100V 6.3X8TR13F	NIC comp.
C2	4.7uF	Capacitor, Electrolytic, 100V, X7R, 20%	6.3x6.3x8	NACEW4R7M100V 6.3X6.3TR13F	NIC comp.
C3	100nF	Capacitor, Ceramic	1608	-	-
C4	1uF	Capacitor, Ceramic	1608	-	-
R <sub>S</sub>	0.27Ω	Resistor, Chip, 1%, 370mA I_LED	3216	-	-

Note1. For component selection, refer to the 'APPLICATION INFORMATION' section.

## Pin Description

Pin No.	Name	Description
1	SW	Switching node. Drain of the integrated Power Switch.
2	GND	Ground. Connect the exposed pad on backside to GND.
3	CS	Current sensing node. Connect resistor R <sub>S</sub> from VIN to CS pin.
4	VIN	Power supply input. Bypass VIN to GND with a suitably large capacitor to eliminate noise on the input to the IC.
5	COMP	Compensation node. Connect capacitor from COMP to GND.
6	PWM	PWM dimming input pin.
7	VDD	Regulated voltage output. (typically 5.2V)
8	ADJ	Linear dimming input pin. Also used for thermal compensation.

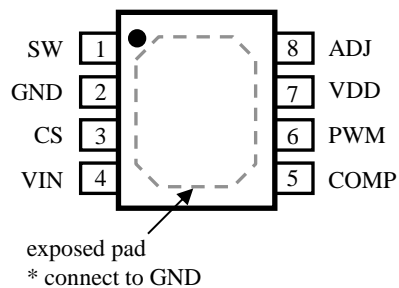

Package outline

\* This specifications are subject to be changed without notice

Functional Block Diagram

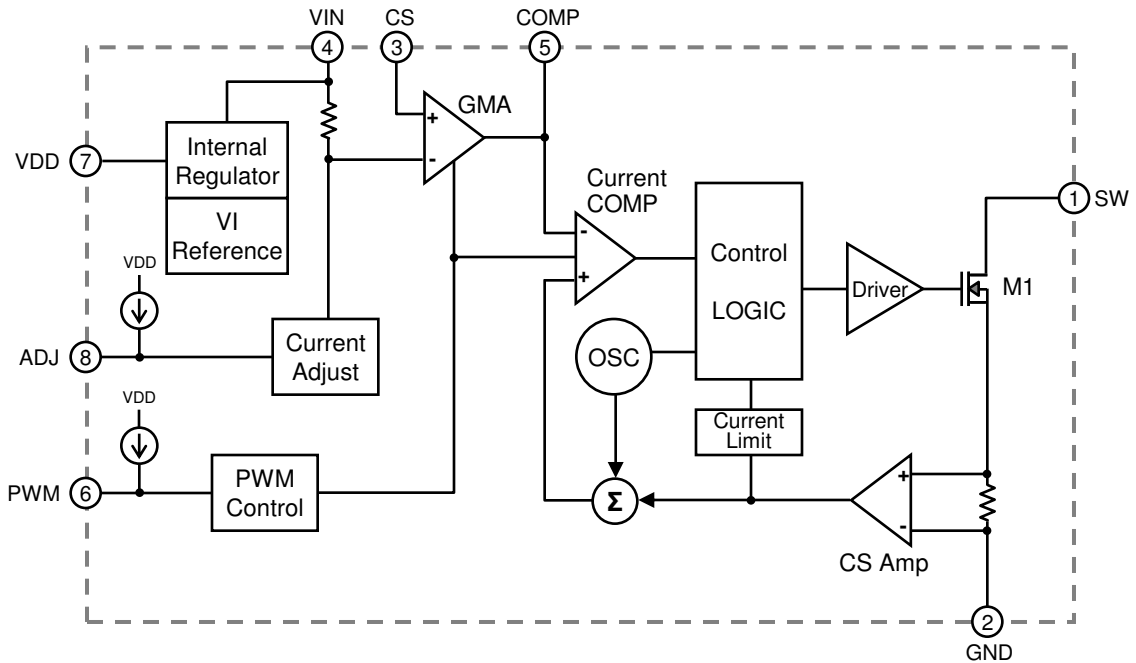

Figure 2. Functional Block Diagram

Absolute Maximum Ratings (Note1)

Parameter	Symbol	Min.	Typ.	Max.	Unit
Power supply voltage	$V_{IN}$	-0.3	-	60	V
SW pin voltage	$V_{SW}$	-0.5	-	60	V
CS pin voltage	$V_{CS}$	-0.3	-	60	V
All Other Pins	-	-0.3	-	6.0	V
Max. power dissipation ( $T_a=25^{\circ}C$ ) (Note2)	$P_D$	-	-	2.08	W
Thermal resistance (Note3)	$\Theta_{JA}$	-	60	-	$^{\circ}C/W$
Storage junction temperature	$T_{STG}$	-65	-	+150	$^{\circ}C$
Junction temperature	$T_{J,MAX}$	-	-	+150	$^{\circ}C$

Note1. Stresses beyond those listed under “Absolute Maximum Ratings” may cause permanent damage to the device.

Note2. Derate 17mW/ $^{\circ}C$  above +25 $^{\circ}C$ . This is recommended to operate under this power dissipation specification.

Note3. Measured on JESD51-7, 4-layer PCB

Operating Ratings

Parameter	Symbol	Min.	Typ.	Max.	Unit
Power supply voltage	$V_{IN}$	6.0	-	60.0	V
VDD voltage	$V_{DD}$	4.8	5.2	5.6	V
Operating temperature	$T_{OPR}$	-40	-	+85	$^{\circ}C$
Junction temperature	$T_J$	-	-	+125	$^{\circ}C$

\* This specifications are subject to be changed without notice

**Electrical Characteristics (Ta=25 °C, V<sub>IN</sub>=12V, I<sub>OUT</sub>=350mA, unless otherwise noted)**

Parameters	Symbol	Condition	Min.	Typ.	Max.	Unit
UVLO rising threshold	V <sub>UVLO</sub>	V <sub>IN</sub> rising	-	5.5	-	V
UVLO falling threshold	V <sub>UVLO_OFF</sub>	V <sub>IN</sub> falling	-	5.2	-	V
Switching frequency	F <sub>SW</sub>	-	255	300	345	kHz
Maximum duty cycle	D <sub>MAX</sub>	3LED, V <sub>IN</sub> =9V	90	95	-	%
<b>Operating Current</b>						
Supply current (quiescent, Note4)	I <sub>Q</sub>	V <sub>IN</sub> = 6/60V, V <sub>PWM</sub> =5V, Open loop	-	1.2	-	mA
Supply current (off)	I <sub>OFF</sub>	V <sub>IN</sub> = 6/60V, V <sub>PWM</sub> =0V	-	0.6	-	mA
<b>Current Sense</b>						
Current Sense threshold voltage	VCS	Mean (V <sub>IN</sub> - V <sub>CS</sub> )	97	100	103	mV
<b>PWM Input</b>						
PWM input high voltage	V <sub>IHPWM</sub>	-	-	1.2	-	V
PWM input low voltage	V <sub>ILPWM</sub>	-	-	1.0	-	V
PWM pull-down current	IPD_PWM	-	-	2.2	-	μA
<b>ADJ Input</b>						
ADJ threshold voltage	VADJ <sub>MAX</sub>	-	-	1.2	-	V
ADJ off voltage	VADJ <sub>OFF</sub>	-	-	50	-	mV
ADJ pull-down current	IPD_ADJ	-	-	2.5	-	μA
<b>Switching TR</b>						
Switch on resistance (Internal, Note4)	R <sub>DS_ON</sub>	1 LED, I <sub>OUT</sub> =0.5A	-	0.5	-	Ω
Switch leakage current (Note4)	I <sub>LEAK</sub>	V <sub>SW</sub> = 60V	-	0.1	5	μA
Current limit	I <sub>CL</sub>	V <sub>IN</sub> =V <sub>CS</sub> =12V	-	1.6	-	A
<b>Thermal Operation</b>						
Thermal shutdown (Note4)	T <sub>OTP</sub>	temperature rising	-	150	-	°C
OTP hysteresis (Note4)	T <sub>OTP_HYS</sub>	temperature falling	-	38	-	°C

Note4. guaranteed by design.

\* This specifications are subject to be changed without notice

## Typical Operating Characteristics

$V_{IN}=12V$ ,  $C1=10\mu F$ ,  $C2=4.7\mu F$ ,  $L1=68\mu H$  and  $T_a=25^\circ C$ , unless otherwise noted

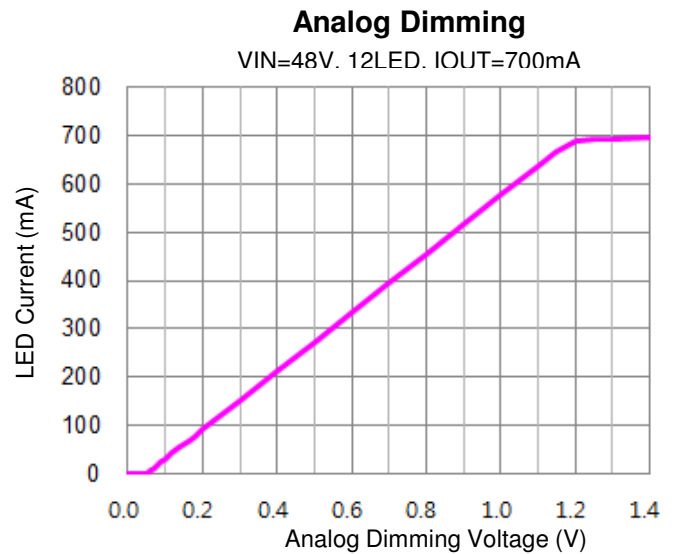
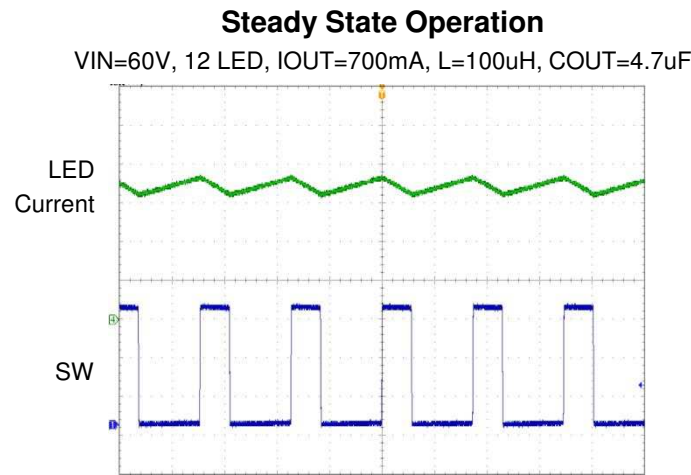
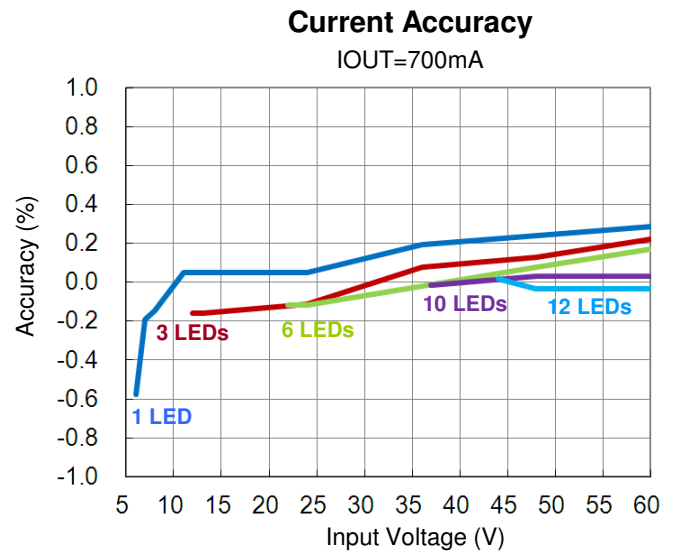
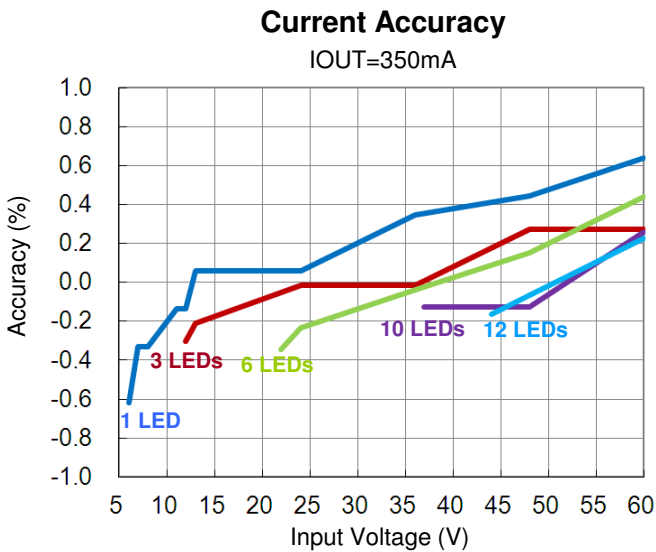
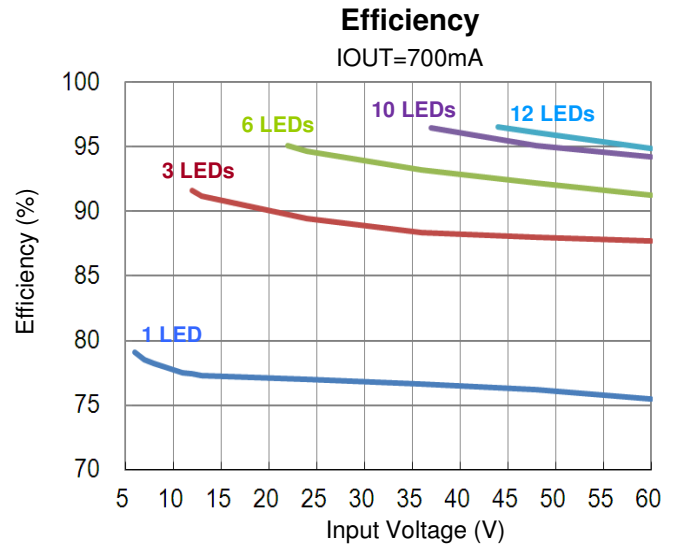
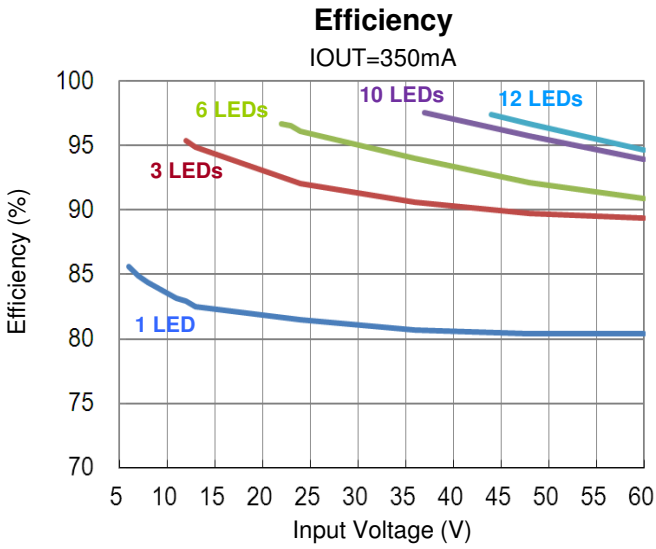

\* This specifications are subject to be changed without notice

## Typical Operating Characteristics

$V_{IN}=12V$ ,  $C1=10\mu F$ ,  $C2=4.7\mu F$ ,  $L1=68\mu H$  and  $T_a=25^\circ C$ , unless otherwise noted

### PWM Dimming

$V_{IN}=36V$ ,  $I_{OUT}=700mA$ , 1 LED

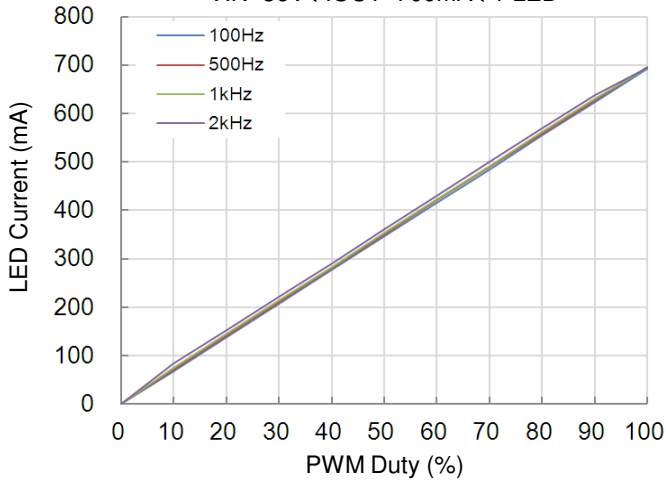

### PWM Dimming

$V_{IN}=36V$ ,  $I_{OUT}=700mA$ , 3 LED

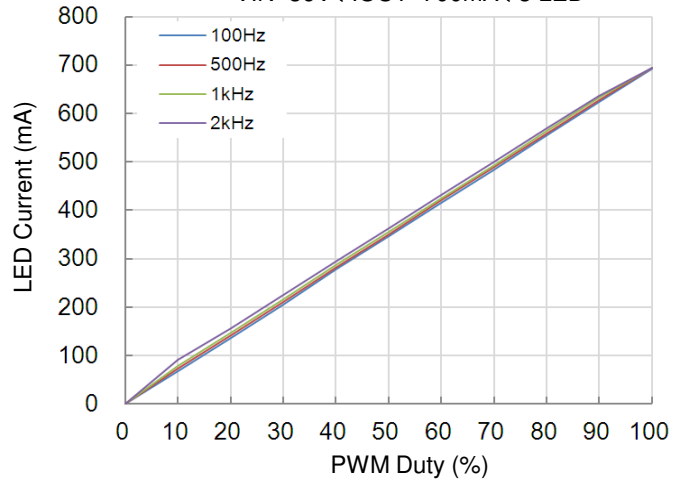

### PWM Dimming

$V_{IN}=36V$ ,  $I_{OUT}=700mA$ , 6 LED

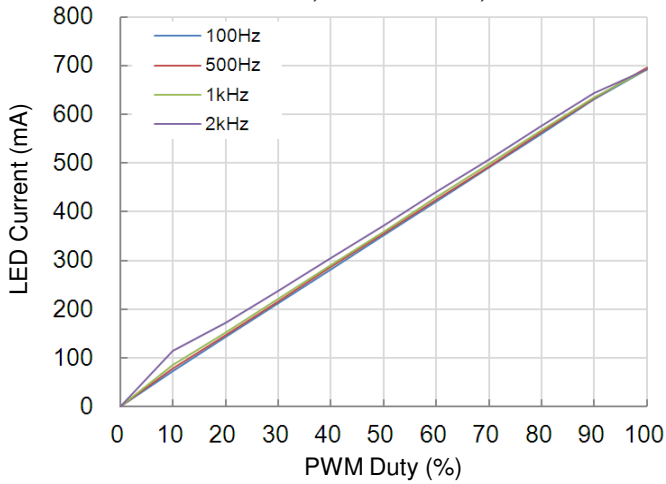

### PWM Dimming

$V_{IN}=48V$ ,  $I_{OUT}=700mA$ , 12 LED

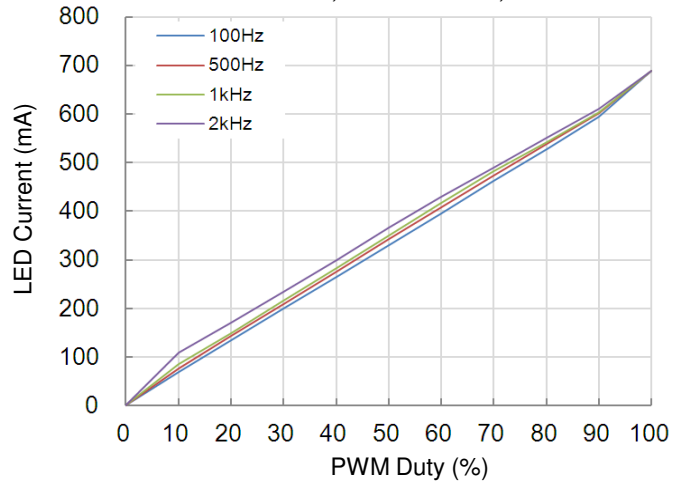

### Accuracy vs. Temperature

$V_{IN}=48V$ ,  $I_{OUT}=700mA$ , 12 LED, 100uH, 4.7uF

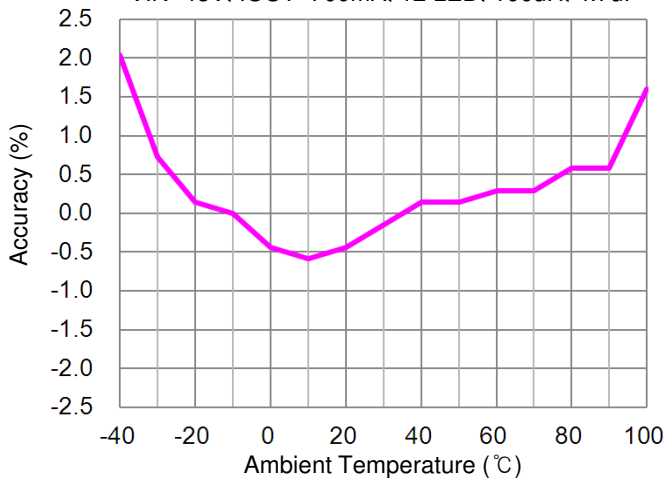

\* This specifications are subject to be changed without notice

**OVERVIEW** (refer to Figure 2. Functional Block Diagram)

The ADT6752 is a current mode step-down converter with integrated low side NMOS power switch. It operates from a 6V to 60V input voltage range and supplies up to 1A of output current. Features include protection functions such as under voltage lockout, soft start, current limit and thermal shutdown protection.

The ADT6752 uses current mode control to regulate the output current. The output current is sensed from VIN to CS pin with the external resistor. This sensed current is compared by the reference current and amplified through the internal transconductance amplifier. The transconductance amplifier output voltage is compared to the internally sensed output current and consequently generated PWM signal. The PWM signal has the information of the LED current and internally sensed current relationship and therefore output current is regulated by its PWM signal control function.

**DETAILED DESCRIPTION****PWM dimming**

The LED brightness can be controlled by applying a pulse-width modulation(PWM) signal to the PWM pin. When PWM pin voltage is high level, the device is working normally. When PWM pin voltage is low level, internal power switch is off. When PWM pin is open, its level is high and the device operates normally. By this function, output current is controlled by the duty of external PWM signal. The average value of output current is given by:

$$I_{OUT(average)} \cong (0.1 \times \text{Duty of PWM}) / R_s \quad , \quad \text{where } R_s \text{ is the external sensing resistor value.}$$

Recommended PWM dimming frequency is 100Hz to 1kHz range to get a good dimming linearity. Available maximum PWM dimming frequency can be up to 2kHz and maximum dimming ratio is up to 500:1.

**Linear dimming**

Besides PWM dimming, ADT6752 has linear dimming function. When ADJ pin voltage increases linearly, output current increases linearly. When ADJ pin open, its voltage is pull up to high level and normal output current set by  $R_s$  value flows. Full output current setting corresponds up to 1.2V typically. So, if needed over 1.2V ADJ dimming voltage, external interface circuitry should be used.

The nominal average output current is given by:

- 1)  $V(ADJ) \geq 1.2V$ , output current =  $0.1 / R_s$
- 2)  $V(ADJ) < 1.2V$ , output current =  $(0.1 / R_s) \times (V(ADJ) / 1.2)$

**Switching frequency jitter function**

ADT6752 has internal frequency jitter function to improve the EMI performance of the system. The internal frequency is hopping in a very small range to reduce the single frequency radiation which simplifies the EMI design.

**Current limit protection**

The output over-current protection (OCP) is implemented using a cycle-by-cycle peak detect control circuit. The switch current is monitored by measuring the low side NMOS switch current. The measured switch current is compared against a preset voltage which represents the current limit, typically 1.6A. When the output current is more than current limit, low side switch will be turned off and PWM duty is reduced. The output current is monitored in the same manner at each cycle and finally the power switch almost turned off not to be damaged under fault conditions.

\* This specifications are subject to be changed without notice

## DETAILED DESCRIPTION (continued)

### Thermal compensation

Linear control of output current can be applied to thermal compensation of the output current. NTC(Negative Temperature Coefficient) resistor, which connected between ADJ pin to GND, can sense thermal variation. By composing proper sensing circuitry and dividing thermal sensing voltage, output current variation by thermal variation can be compensated. As temperature increase, ADJ pin voltage decrease and output current will decrease following the rising temperature.

If thermal compensation and analog dimming are not used, open ADJ pin for pull-up to VDD.

## APPLICATION INFORMATION

Figure 1 is the typical ADT6752 application circuit. And Figure 2 is the functional block diagram of the ADT6752. For the application information, refer to the Figure 1 & 2 unless otherwise noted.

### LED Current Resistor Selection

The nominal average output current in the LED(s) is determined by the value of the external current sense resistor  $R_s$  connected VIN pin and CS pin.  $R_s$  is recommended to use 1% tolerance or better resistor. LED current is calculated by the below equation.

$$I_{LED} = 100\text{mV} / R_s \quad \text{for } R_s \geq 0.07\Omega$$

Note that  $R_s = 0.07\text{ohm}$  is the minimum allowed value of sense resistor under these conditions to maintain switch current below the specified maximum value.

The table below gives values of nominal average output current for several preferred values of current setting resistor  $R_s$  in the typical application circuit :

RS	Nominal average output current
0.083 $\Omega$ (0.1 $\Omega$ // 0.5 $\Omega$ )	1200 mA
0.01 $\Omega$	1000 mA
0.14 $\Omega$	714 mA
0.27 $\Omega$	370 mA

The above values assume that the ADJ pin is floating or high level. In this condition, analog dimming function is not available. It is possible to use different values of  $R_s$  if the ADJ pin is driven from an external voltage for analog dimming function.

### Inductor Selection

The inductor required to supply constant current to the output load when it is driven by a switching voltage. For given input and output voltage, inductance and switching frequency together decide the inductor ripple current, that is:

$$\Delta I_L \approx \frac{V_{LED}}{F_{SW} \times L} \times \left( 1 - \frac{V_{LED}}{V_{IN}} \right)$$

\* This specifications are subject to be changed without notice



## APPLICATION INFORMATION (continued)

The peak inductor current is:

$$I_{L,peak} = I_{LED} + \frac{\Delta I_L}{2}$$

Higher inductance gives low inductor ripple current but requires larger size inductor to avoid saturation. Low ripple current reduces inductor core losses. Also it reduces RMS current through inductor and switches, which results in less conduction loss. Usually, the selected effective current (Rated Current, Max) of inductor should be bigger than 20% to 30% of the max. output current. Make sure it is capable to handle the peak current without saturation.

Surface mount inductors in different shape and styles are available from TDK, EROCORE, TOKO and Murata. Shielded inductors are small and radiate less EMI noise. But they cost more than unshielded inductors. The choice depends on EMI requirement, price and size.

### Input Capacitor Selection

The input capacitor is used to filter out discontinuous, pulsed input current and to maintain input voltage stable. Therefore input capacitor should be able to supply the AC current to the converter. Its input ripple voltage can be estimated by:

$$\Delta V_{IN} \approx \frac{I_{LED}}{F_{SW} \times C_{IN}} \times \frac{V_{LED}}{V_{IN}} \times \left(1 - \frac{V_{LED}}{V_{IN}}\right)$$

where,  $C_{IN}$  is input capacitor value and  $V_{LED}$  is the drop voltage of the series connected LED(s).

The voltage rating of input capacitor must be greater than the maximum input voltage plus ripple voltage.

Since the input capacitor absorbs the input switching current, it requires an proper ripple current rating. The RMS current in the input capacitor can be approximated by:

$$I_{CIN\_RMS} \approx I_{LED} \times \sqrt{\frac{V_{LED}}{V_{IN}} \times \left(1 - \frac{V_{LED}}{V_{IN}}\right)}$$

The worst-case condition occurs at  $V_{IN}=2 \times V_{OUT}$  (50% duty condition), and its worst RMS current is approximately half of the  $I_{OUT}$ . For reliable operation and best performance, the input capacitors must have current rating higher than  $I_{CIN\_RMS}$  at worst operating conditions.

The input capacitor is recommended to be more than 10uF. And the input capacitor should be positioned as close to the VIN pin as possible.

### Output Capacitor Selection

The output capacitor, which connected between VIN and series connected LED(s) negative terminal, reduces peak to peak ripple current in the LED(s). Low ESR capacitors are preferred to keep the output current ripple low. As the low ESR ceramic capacitor has normally lower voltage rating, it is difficult to use at higher VIN applications. For high VIN applications, tantalum or electrolytic capacitors are used normally as the output capacitor. In the case of tantalum or electrolytic capacitors, LED voltage ripple dominates by the ESR of output capacitor and the inductor current ripple.

$$\Delta V_{OUT} \approx \Delta I_L \times (ESR)$$

Proportionally lower ripple voltage can be achieved with higher capacitor values. It is recommended to use the capacitor of 4.7uF or larger. Note that the capacitor will increase startup delay, its delay will limit the PWM dimming performance.

\* This specifications are subject to be changed without notice

## APPLICATION INFORMATION (continued)

### Output Freewheeling Diode

When the low side switch is off, the storage current in inductor freewheels to the VIN. The forward voltage and reverse recovery times of the freewheeling diode are the key loss factors, so schottky diode is mostly used for the freewheeling diode. Choose a diode whose maximum reverse voltage rating is greater than the maximum input voltage, and whose current rating is greater than the maximum load current.

The average current through the diode is :

$$I_{\text{Diode}} = (1 - \text{Duty of PWM}) \times \text{LED current}$$

### Thermal Management

The ADT6752 contains an internal thermal sensor that limits the total power dissipation in the device and protects it in the event of an extended thermal fault condition. When the die temperature exceeds +150°C typically, the thermal sensor shuts down the device, turning off the converter to allow the die to cool. After the die temperature falls by 38°C typically, the device automatically restarts to operate normally.

The ADT6752 is available in a thermally enhanced SOP package and can dissipate up to 2.0W at room temperature condition. The exposed pad should be connected to GND externally, preferably soldered to a large ground plane to maximize thermal performance. Maximum available power dissipation should be derated by 17mW/°C above Ta=25°C not to damage the device.

### PCB Layout Consideration

PCB layout is very important to achieve clean and stable operation. It is highly recommended to follow below guidelines for good PCB layout.

1. Input capacitor (C1) should be placed as near as possible to the IC and connected with direct traces.
2. Keep the high current paths as short and wide as possible.
3. Keep the switching current path short and minimize the loop area, formed by SW, the output capacitors and the input capacitors.
4. Route high-speed switching nodes (such as SW) away from sensitive analog areas (such as CS, VDD and COMP).
5. Ensure all feedback connections are short and direct. Place the Rs , C3 and C4 components as close as possible to the IC.
6. Exposed pad of device must be connected to GND with solder.

\* This specifications are subject to be changed without notice

Package : eSOP8L(with exposed pad), 4.9mm x 3.9mm body (units : mm)

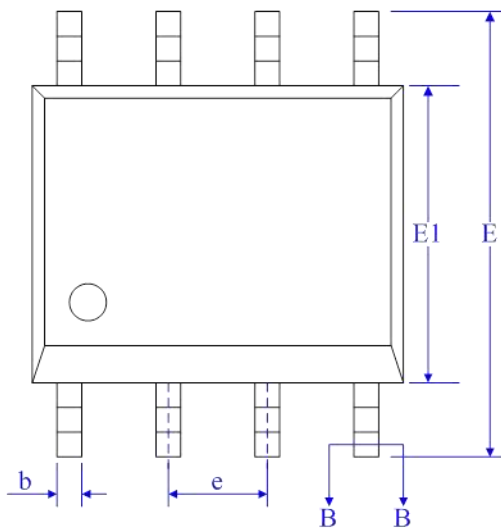
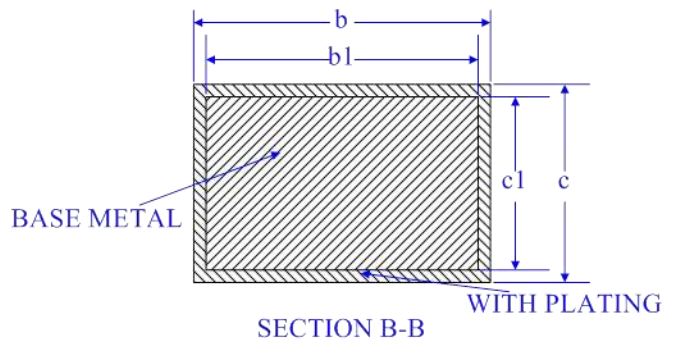
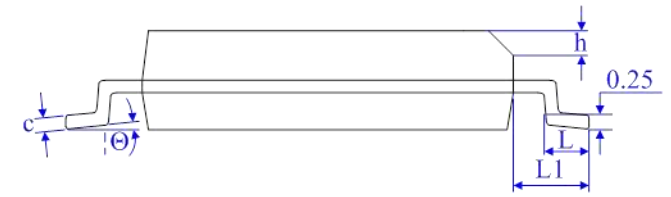
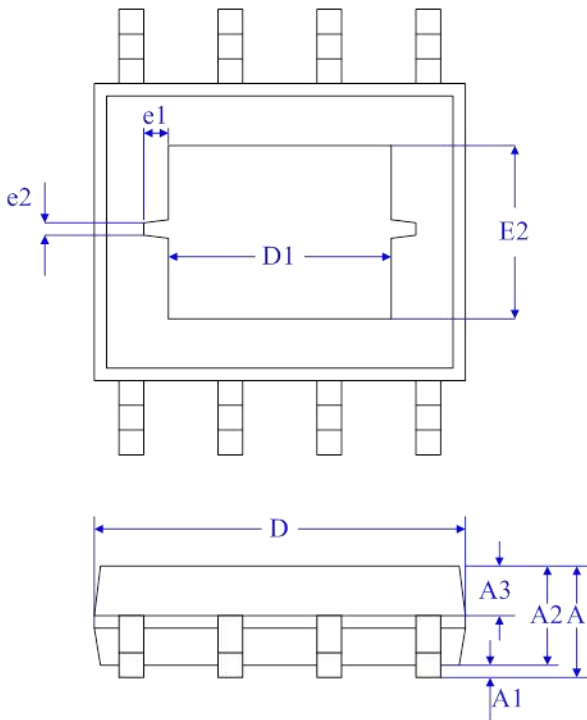

SYMBOL	MILLIMETER		
	MIN	NOM	MAX
A	—	—	1.75
A1	0.05	—	0.15
A2	1.30	1.40	1.50
A3	0.60	0.65	0.70
b	0.39	—	0.48
b1	0.38	0.41	0.43
c	0.21	—	0.26
c1	0.19	0.20	0.21
D	4.70	4.90	5.10
E	5.80	6.00	6.20
E1	3.70	3.90	4.10
e	1.27BSC		
e1	0.51REF		
e2	0.25REF		
h	0.25	—	0.50
L	0.50	—	0.80
L1	1.05BSC		
Θ	0	—	8"
D1	2.13REF		
E2	2.13REF		

\* This specifications are subject to be changed without notice