

AEDR-871x

3-Channel High Resolution Reflective Incremental Encoder (Digital Outputs)

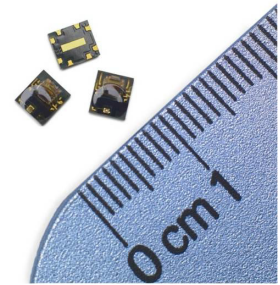

Description

The Broadcom[®] AEDR-871x encoder is the smallest 3-channel optical encoder with digital outputs that employs Reflective Technology for motion control.

The encoder is designed to operate over the -40°C to 85°C temperature range and so is suitable for both commercial and industrial applications.

AEDR-871x offers high resolution (318 LPI) with built-in interpolation, enabling great flexibility and versatility in resolution range.

The compact dimensions of $3.95\text{ mm (L)} \times 3.4\text{ mm (W)} \times 0.9562\text{ mm (H)}$ coupled with the low operating 3.3V option allows it to be used in a wide range of miniature commercial applications and portable devices in which space and power consumption is a primary concern.

AEDR-871x encoder offers two-channel (AB) quadrature digital outputs and a third channel, index digital outputs. Being TTL compatible, the outputs of the AEDR-871x encoder can be interfaced directly with most of the signal processing circuitries. Therefore, the encoder provides great design-in flexibility and easy integration into existing systems.

Features

- World's smallest 3-channel reflective technology encoder
- Digital Output option – 3 channels TTL compatible; 2 channel quadrature (AB) digital outputs for direction sensing and a third channel, Index digital output. Built-in interpolator for 4 \times , 8 \times , and 16 \times interpolation.
- Surface mount leadless package $3.95\text{ mm (L)} \times 3.4\text{ mm (W)} \times 0.9562\text{ mm (H)}$
- Operating voltage of 3.3V or 5V supply
- Built-in LED current regulation, removing the need for external biasing resistor
- -40°C to 85°C absolute operating temperature
- Encoding resolution: 318 (lines/inch, LPI)

Applications

- Ideal for high volume applications:
- Miniature motors
- Printers and copiers
- Card readers
- Miniature camera module
- Portable measurement devices
- Healthcare, lab diagnostic equipment and portable devices
- Optometric equipment
- Consumer and industrial product applications

Output Waveform

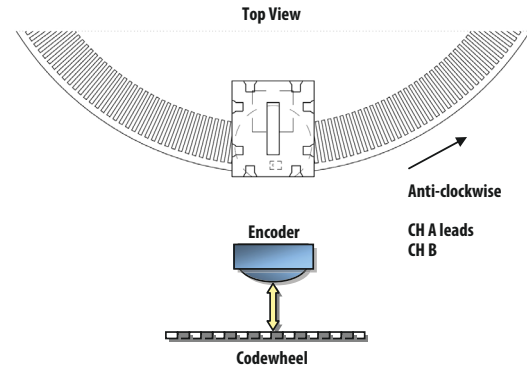
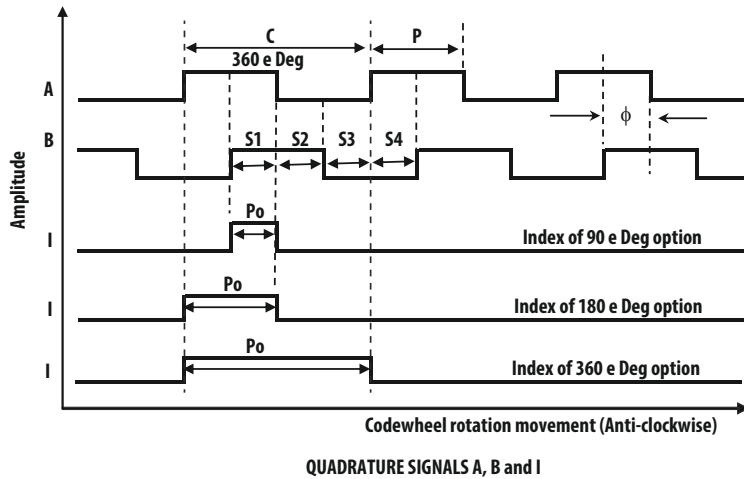

Note: Drawing not to scale

Test Parameter Definitions

Parameter	Symbol	Description
Count	N	The number of bar and window pairs, or counts per revolution (CPR), of the codewheel.
One Cycle	C	360 electrical degrees ($^{\circ}e$), 1 bar and window pair.
One Shaft Rotation		360 mechanical degrees, N cycles.
Cycle Error	ΔC	An indication of cycle uniformity. The difference between an observed shaft angle that gives rise to one electrical cycle, and the nominal angular increment of $1/N$ of a revolution.
Pulse Width (Duty)	P	The number of electrical degrees that an output is high during 1 cycle. This value is nominally $180^{\circ}e$ or $1/2$ cycle.
Pulse Width (Duty) Error	ΔP	The deviation, in electrical degrees, of the pulse width from its ideal value of $180^{\circ}e$.
State	S	The number of electrical degrees between a transition in the output of channel A and the neighboring transition in the output of channel B. There are 4 states per cycle, each nominally $90^{\circ}e$.
State Error	ΔS	The deviation, in electrical degrees, of each state width from its ideal value of $90^{\circ}e$.
Phase	ϕ	The number of electrical degrees between the center of the high state of channel A and the center of the high state of channel B. This value is nominally $90^{\circ}e$ for quadrature output.
Phase Error	$\Delta \phi$	The deviation of the phase from its ideal value of $90^{\circ}e$.
Optical Radius	R_{OP}	The distance from the codewheel's center of rotation to the optical center (O.C.) of the encoder module.
Index Pulse Width	P_O	The number of electrical degrees that an index is high during one full shaft rotation.

Absolute Maximum Ratings

Parameter	Value
Storage Temperature, T_S	-40°C to 85°C
Operating Temperature, T_A	-40°C to 85°C
Supply Voltage, V_{CC}	7V

NOTE:

1. Exposure to extreme light intensity (such as from flashbulbs or spotlights) may cause permanent damage to the device.
2. Proper operation of the encoder cannot be guaranteed if the maximum ratings are exceeded.

ATTENTION: To avoid damage or degradation induced by ESD, take normal static precautions when handling the encoder.

Recommended Operating Conditions

Parameter	Symbol	Min.	Typ.	Max.	Units	Notes
Operating Temperature	T_A	-40	25	85	°C	
Supply Voltage	V_{CC}	3.0	3.3	3.6	V	Ripple < 100 mV _{p-p}
		4.5	5	5.5		
Current	I_{CC}	—	27	60	mA	
Output Frequency	F	—	—	240	kHz	4× Interpolation
	F	—	—	480	kHz	8× Interpolation
	F	—	—	960	kHz	16× Interpolation
Radial Misalignment	E_R	—	—	± 0.2	mm	
Tangential Misalignment	E_T	—	—	± 0.2	mm	
Codewheel Gap	G	0.5	0.75	1.0	mm	

Recommended Codewheel Characteristics

Parameter	Symbol	Min.	Max.	Unit	Notes
Window/Bar Ratio	W_W/W_B	0.9	1.1		
Window/Bar Length	L_W	1.80 (0.071)	—	mm (inches)	
Specular Reflectance	Rf	60	—		Reflective area ^a
		—	10		Non-reflective area
Line Density	LPmm ^b	12.52	lines/mm		
	LPI	318	lines/inch		

a. Measurements from TMA μ Scan meter

b. LPmm = $CPR/[2\pi \cdot R_{op}(mm)]$.

Encoder Pinouts

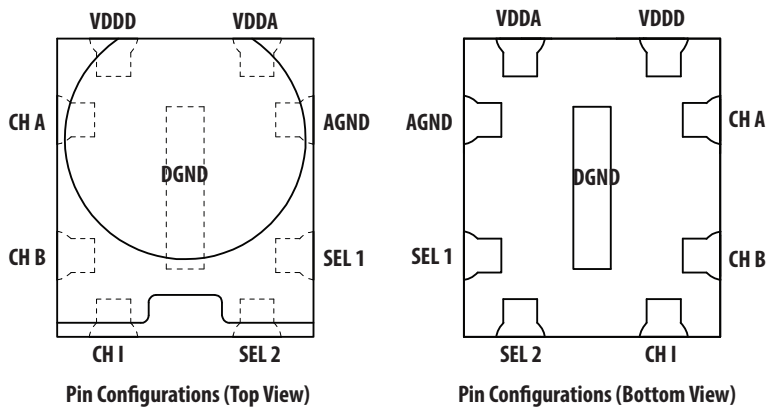

Digital Option – Encoder's Built-in Interpolation

Pin (Interpolation)		Interpolation Factor	Max. Output Frequency	Example of CPR @ $R_{OP} = 11 \text{ mm}$
SEL 1	SEL 2			
H ^a	H ^a	4'	240 kHz	3460
L ^b	L ^b	8'	480 kHz	6920
H ^a	L ^b	16'	960 kHz	13840

a. HIGH Logic Level.

b. LOW Logic Level.

This interpolation factor may be used with the following formula to cater to the need for various rotation speeds (RPM) and counts.

$$\text{RPM} = (\text{Count Frequency} \times 60) / \text{CPR}$$

The CPR (@1' interpolation) is based on the following formula, which is directly dependent on ROP:

$$\text{CPR} = \text{LPI} \times 2\pi \times R_{OP} (\text{inch}) \text{ or } \text{CPR} = \text{LPmm} \times 2\pi \times R_{OP} (\text{mm})$$

NOTE: LPmm (lines per mm) = LPI/25.4.

Recommended Setup For the Power Supply Pins

Connect both V_{DDDD} , V_{DDDA} and their corresponding grounds (AGND and DGND) appropriately as follows. It is recommended that you use 22 μF and 0.1 μF for bypass capacitor on V_{DDDD} and V_{DDDA} and place them in parallel as close as possible to the power and the ground pins.

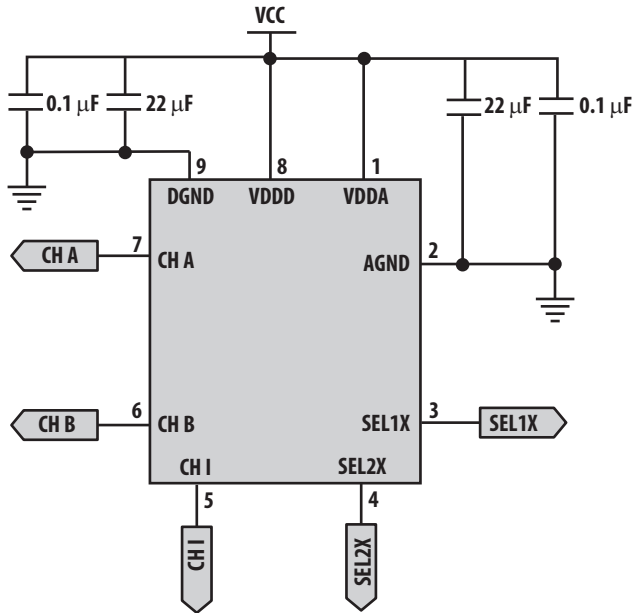

NOTE:

1. DGND (Pin 9) is the center pad of the package.
2. For SEL1X and SEL2X configuration, see the Digital Option – Encoder's Built-in Interpolation table.

Encoding Characteristics (Codewheel of R_{OP} @ 11 mm)

Parameter	Symbol	Dynamic Performance			Unit
		Typical			
Interpolation Factor		4×	8×	16×	
Cycle Error	ΔC	± 17	± 28	± 35	$^{\circ}e$
Pulse Width (Duty) Error	ΔP	± 14	± 18	± 22	$^{\circ}e$
Phase Error	$\Delta \emptyset$	± 5	± 8	± 9	$^{\circ}e$
State Error	ΔS	± 8	± 10	± 13	$^{\circ}e$
Index Pulse Width (Gated 90°)	Po	90	90	90	$^{\circ}e$
Index Pulse Width (Gated 180°)	Po	180	180	180	$^{\circ}e$
Index Pulse Width (Gated 360°)	Po	360	360	360	$^{\circ}e$

NOTE:

1. Typical values represent the average values of encoder performance in our factory-based setup conditions.
2. The optimal performance of the encoder depends on the motor/system setup condition of the individual customer.

Electrical Characteristics

Characteristics over recommended operating conditions at 25°C.

Parameter	Symbol	Min.	Typ.	Max.	Unit	Notes
High Level Output Voltage	V_{OH}	2.4	—	—	V	$I_{OH} = -4 \text{ mA}$
Low Level Output Voltage	V_{OL}	—	—	0.4	V	$I_{OH} = +4 \text{ mA}$
Output current per channel, I _{out}	I_o	—	—	4	mA	
Rise Time	t_r	—	< 100	—	ns	$C_L \leq 50 \text{ pF}$
Fall Time	t_f	—	< 100	—	ns	

Codewheel Design Guideline

The index bar (I-) track is opaque and the width is $3 \times W_B^\circ$. The Index (I) track is reflective and the width is $3 \times W_W^\circ$. The dimension L_W should be at least 1.8 mm. (Note: If L_W shorter than 1.8 mm is required, consult the factory). There are six pairs of incremental track (1 pair = $1 W_B^\circ$ and $1 W_W^\circ$) between opaque and reflective index tracks.

Figure 1: Codewheel Design Example

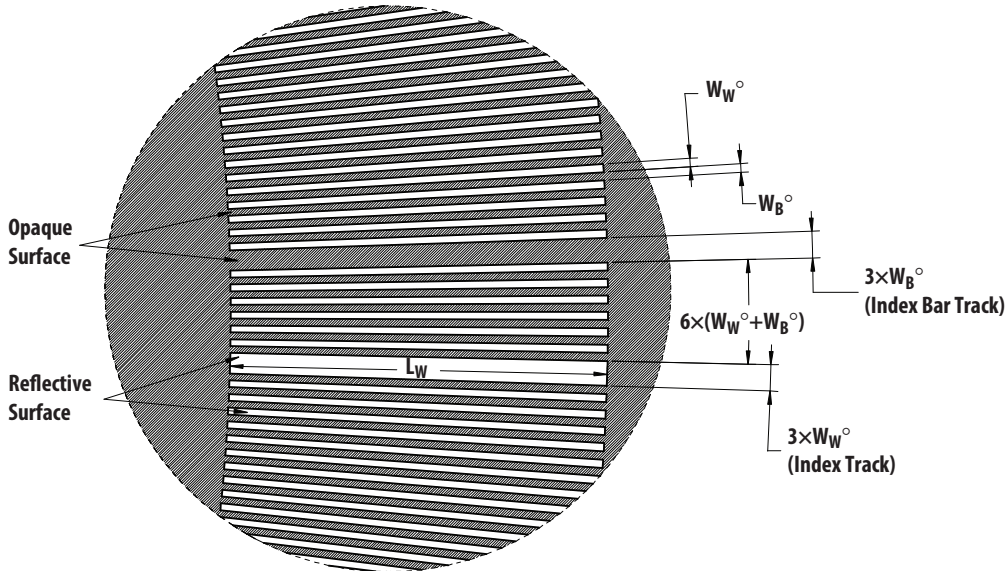

The following demonstrates a codewheel design for R_{op} of 11 mm @ 865 CPR for a 2-channel and a 3-channel encoder.

Figure 2: Codewheel Pattern for a 2-Channel Encoder

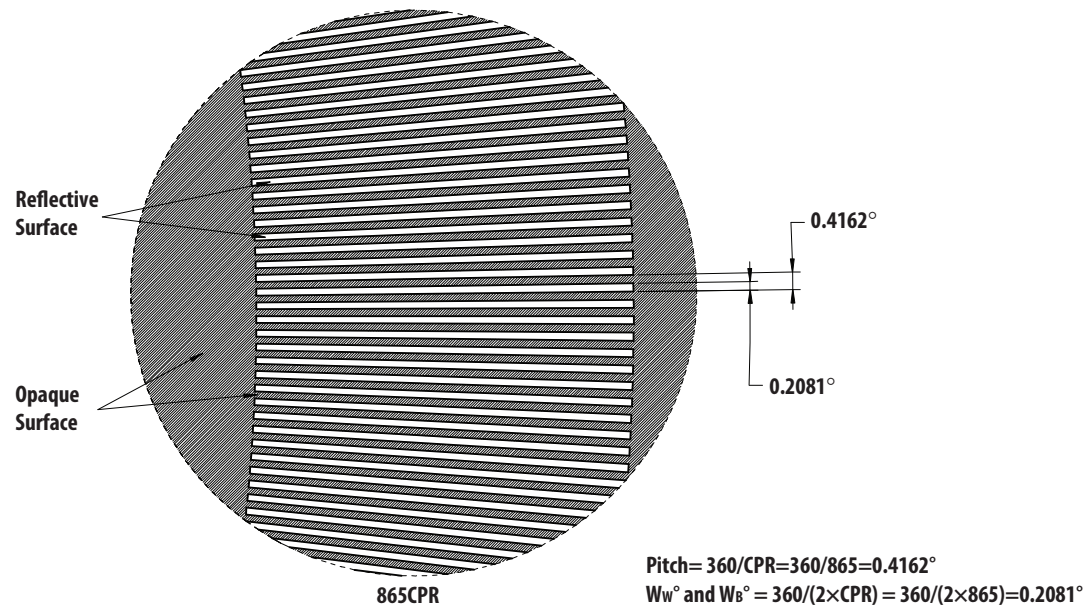
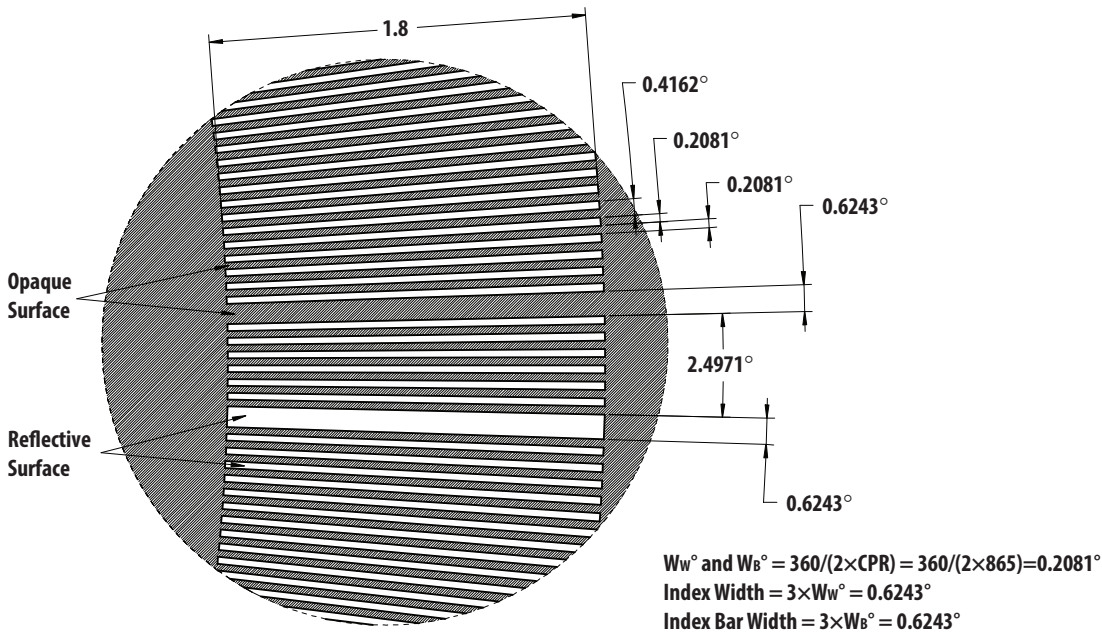
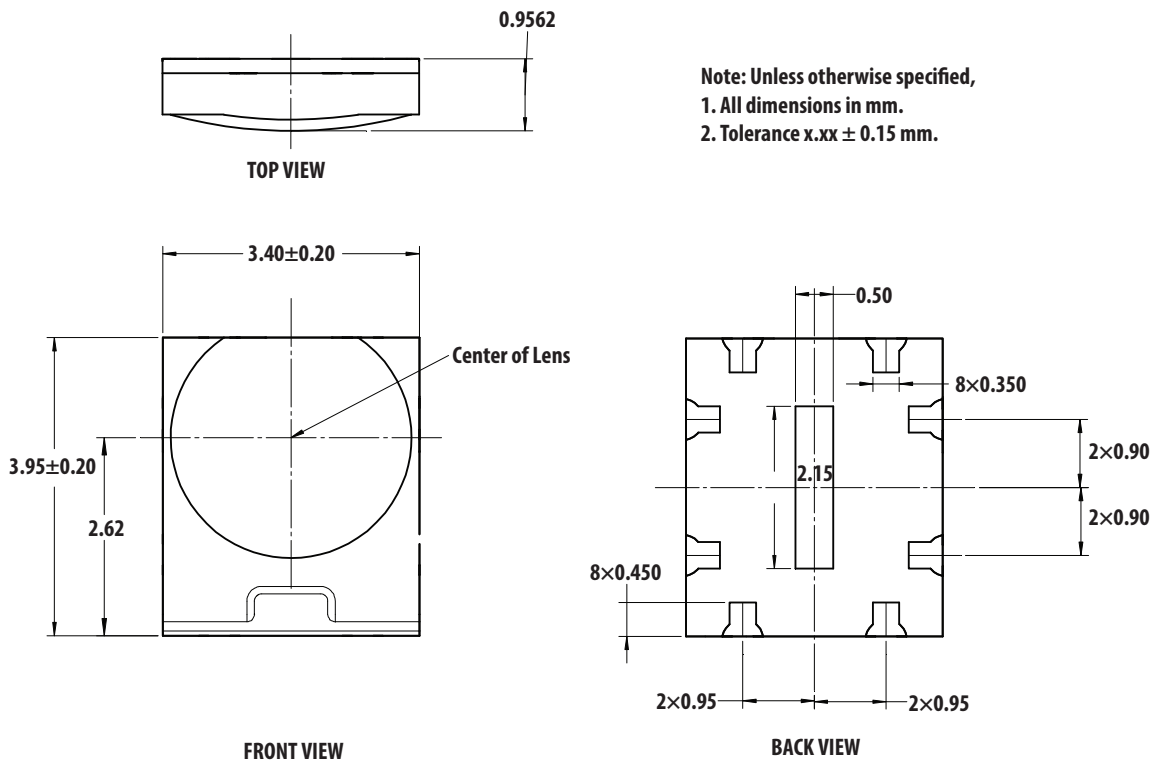

Figure 3: Codewheel Pattern for a 3-Channel Encoder



NOTE: The overall physical track count is reduced but not the counts per revolution (CPR). The CPR *remains the same* because the count during this index transition is generated by an intelligent signal processing circuit.

Package Outline Drawing



Recommended Land Pattern

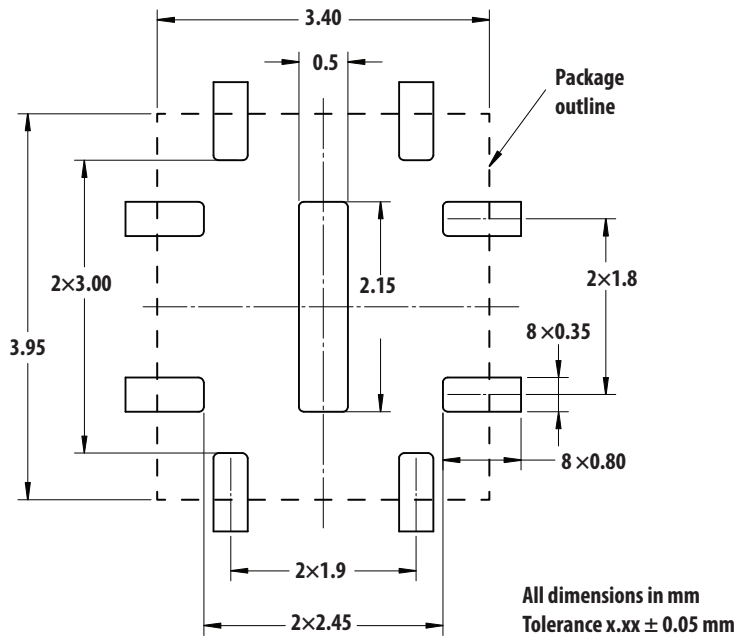

Encoder Placement Orientation and Positioning

The AEDR-871x is designed such that both the emitter and the detector ICs are placed parallel to the window/bar orientation, *with the encoder mounted on top of the codewheel* (see below right). When properly oriented, the detector side will be closer to the center of codewheel than the emitter. More importantly, *the center of the lens* of the encoder unit must be aligned with the codewheel (R_{OP}), or more specifically tangential to the center point of L_W (1/2 of the length of the window).

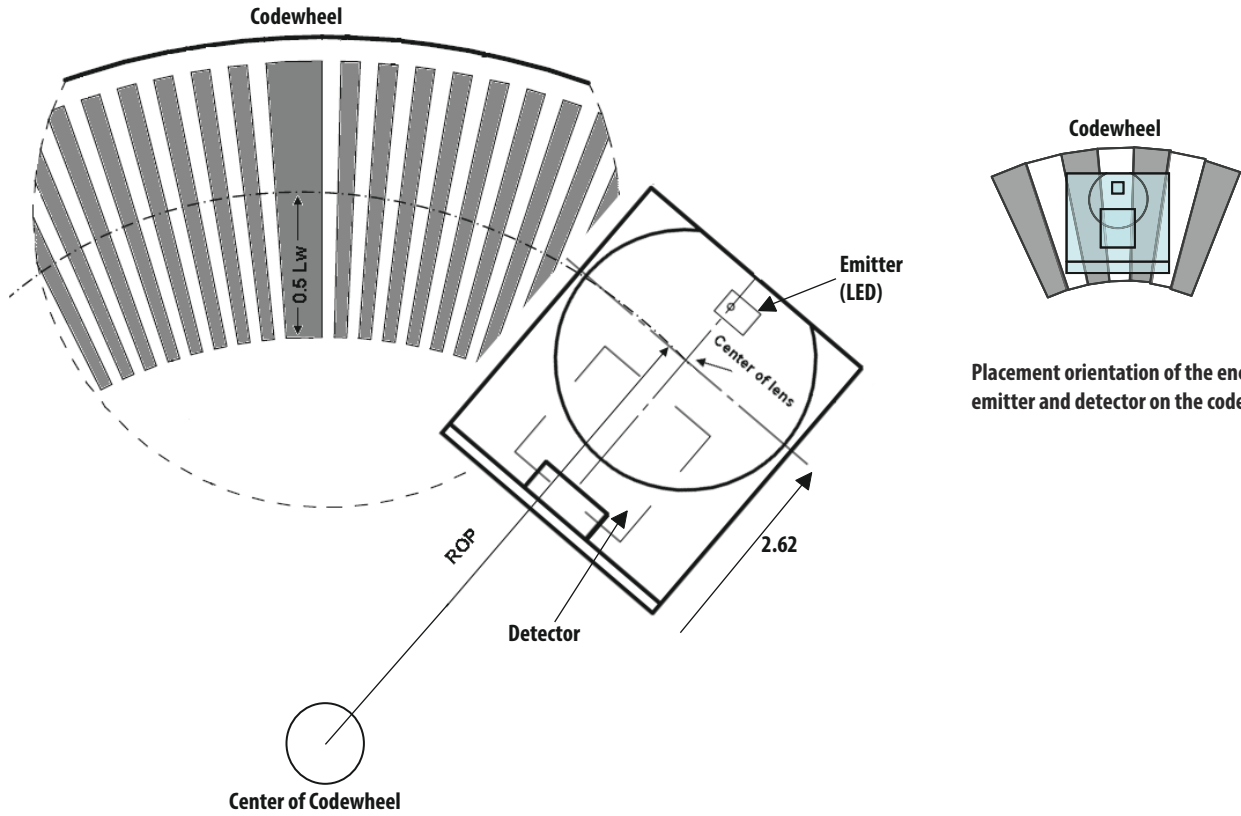

Placement orientation of the encoder's emitter and detector on the codewheel

Center of the lens should be aligned with the R_{OP} of the codewheel

Direction of Movement

With the detector side of the encoder placed closer to the codewheel (see the figure on the previous page), Channel A leads Channel B when the codewheel rotates anti-clockwise and vice versa (*with the encoder mounted on top of the codewheel*). The optimal gap setting recommended is between 0.5 mm to 1.0 mm (see the side view below).

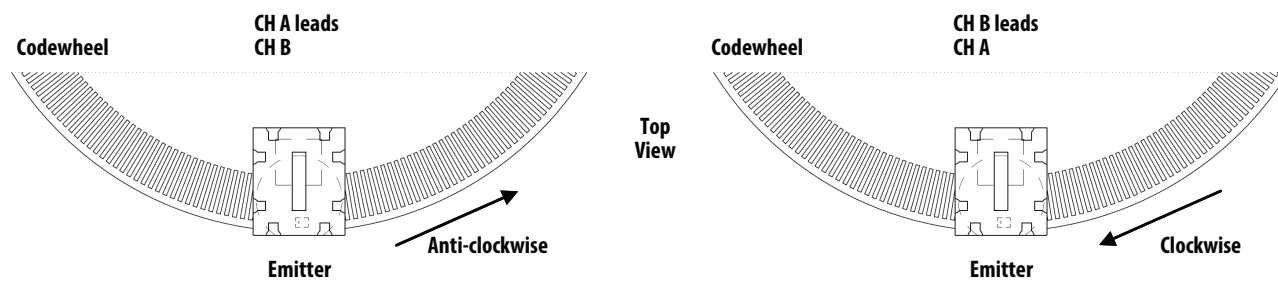
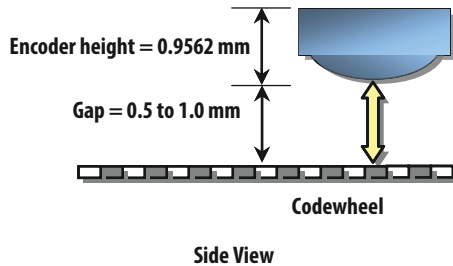

Note: Drawing not to scale

Moisture Sensitivity Level

The AEDR-871x is specified to Moisture Sensitive Level (MSL) 3. Precaution is required to handle this moisture-sensitive product to ensure the reliability of the product.

Storage before use:

- An unopened moisture barrier bag (MBB) can be stored at < 40°C/90% RH for 12 months.
- It is not recommended that the MBB is opened before assembly.

Control after the MBB is opened:

- Encoder that will be subjected to reflow solder must be mounted within 168 hours of factory condition <30°C/60% RH.

Control for unfinished reel:

- Stored and sealed MBB with desiccant or desiccators at < 5% RH.

Baking is required if:

- Humidity Indicator Card (HIC) is > 10% when read at 23°C ± 5°C.
- The encoder floor life exceeded 168 hours.
- Recommended baking condition: 60°C ± 5°C for 20 hours (tape and reel), 125°C ± 5°C for 5 hours (loose unit).

Recommended Lead-free Reflow Soldering Temperature Profile

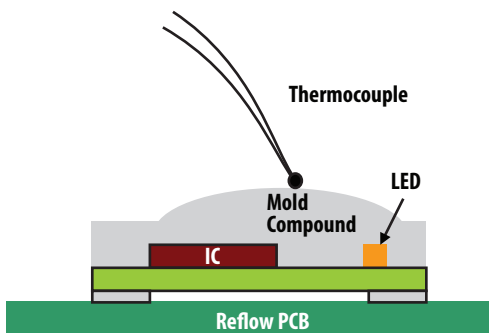
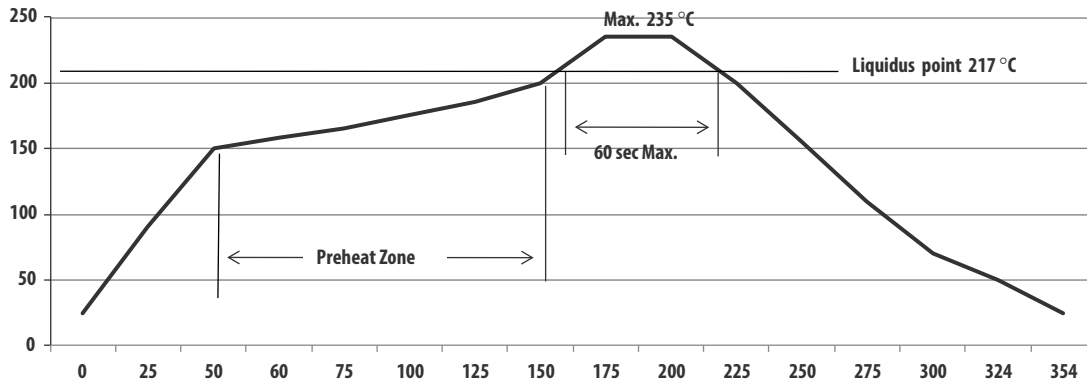

Average ramp up rate	= 3°C/s
Average ramp down rate	= 6°C/s
Preheat temperature	= 150°C to 200°C
Preheat time	= 60s to 100s
Time maintain above 217°C	= 40s to 60s
Peak temperature	= 235°C
Time within 5°C of peak temperature	= 20s to 30s

NOTE:

1. Reflow with peak temperature > 235°C may damage the component.
2. Due to treatment of high temperature, this clear compound may turn yellow after IR reflow.
3. Profile shown here is the actual readings from the thermocouple (attached to AEDR-871x as shown above) on the reflow board PCB.

Tape and Reel Information

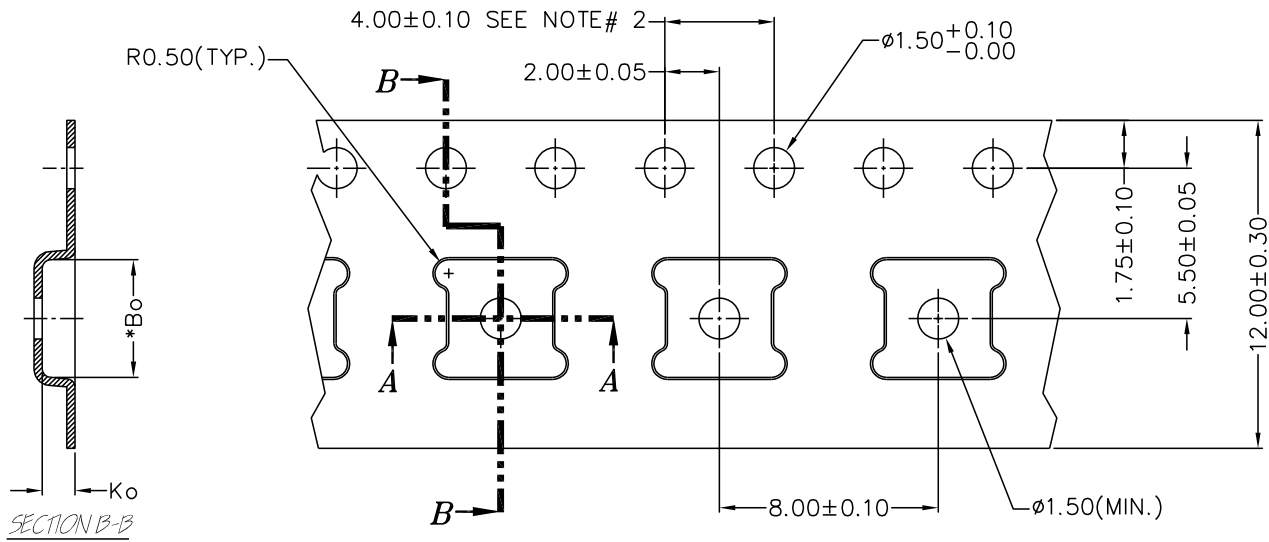

SECTION B-B

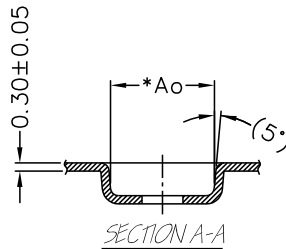

SECTION A-A

NOTES: -

1. * Ao & Bo measured at 0.3mm above base of pocket.
2. 10 pitches cumulative tol. ±0.2mm.
3. () Reference dimensions only.

<i>Ao:</i>	3.80
<i>Bo:</i>	4.30
<i>Ko:</i>	1.20
<i>Pitch:</i>	8.00
<i>Width:</i>	12.00

Order Information

AEDR - 87xx - x 0 x

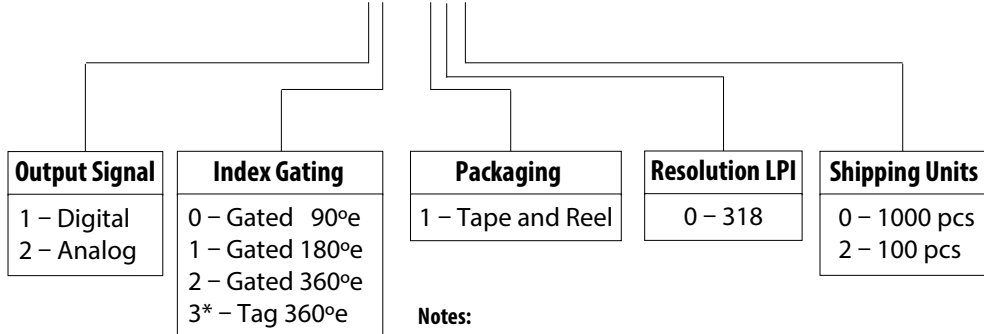

Notes:
 Digital 3.3V and 5V operating mode
 Analog: 5V operating mode only
 Index Gating: 3* applicable only for analog output

Disclaimer

Broadcom's products and software are not specifically designed, manufactured, or authorized for sale as parts, components, or assemblies for the planning, construction, maintenance, or direct operation of a nuclear facility or for use in medical devices or applications. The customer is solely responsible, and waives all rights to make claims against Broadcom or its suppliers, for all loss, damage, expense, or liability in connection with such use.

Broadcom, the pulse logo, Connecting everything, Avago Technologies, Avago, and the A logo are among the trademarks of Broadcom and/or its affiliates in the United States, certain other countries and/or the EU.

Copyright © 2014–2017 Broadcom. All Rights Reserved.

The term "Broadcom" refers to Broadcom Limited and/or its subsidiaries. For more information, please visit www.broadcom.com.

Broadcom reserves the right to make changes without further notice to any products or data herein to improve reliability, function, or design. Information furnished by Broadcom is believed to be accurate and reliable. However, Broadcom does not assume any liability arising out of the application or use of this information, nor the application or use of any product or circuit described herein, neither does it convey any license under its patent rights nor the rights of others.