

## 1A Bipolar Linear Regulator

### ● Features

- Maximum output current is 1A
- Range of operation input voltage: Max 15V
- Line regulation: 0.03%/V (typ.)
- Standby current: 2mA (typ.)
- Load regulation: 0.2%/A (typ.)
- Environment Temperature: -20°C~85°C

### ● General Description

AF1117 is a series of low dropout three-terminal regulators with a dropout of 1.3V at 1A load current. AF1117 features a very low standby current 2mA compared to 5mA of competitor.

Other than a fixed version,  $V_{out} = 1.2V, 1.8V, 2.5V, 3.3V, 5V,$  and  $12V$ , AF1117 has an adjustable version, which can provide an output voltage from 1.25 to 12V with only two external resistors.

AF1117 offers thermal shut down and current limit functions, to assure the stability of chip and power system. And it uses trimming technique to guarantee output voltage accuracy within 2%. Other output voltage accuracy can be customized on demand, such as 1%. AF1117 is available in SOT-223, TO-252 power package.

### ● Applications

- Power Management for Computer Mother Board, Graphic Card
- LCD Monitor and LCD TV
- DVD Decode Board
- ADSL Modem
- Post Regulators For Switching Supplies

### ● Typical Application

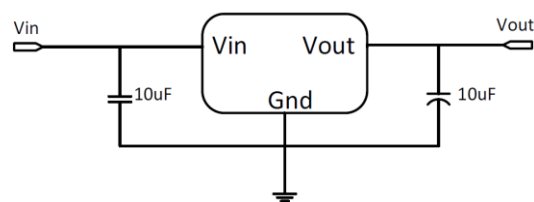

Application circuit of AF1117 fixed version

### ● Typical Electrical Characteristic

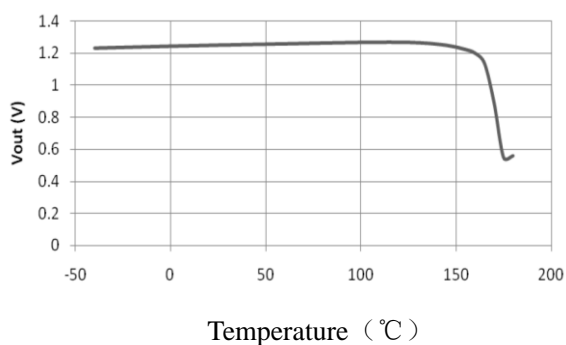

● **Block Diagram**

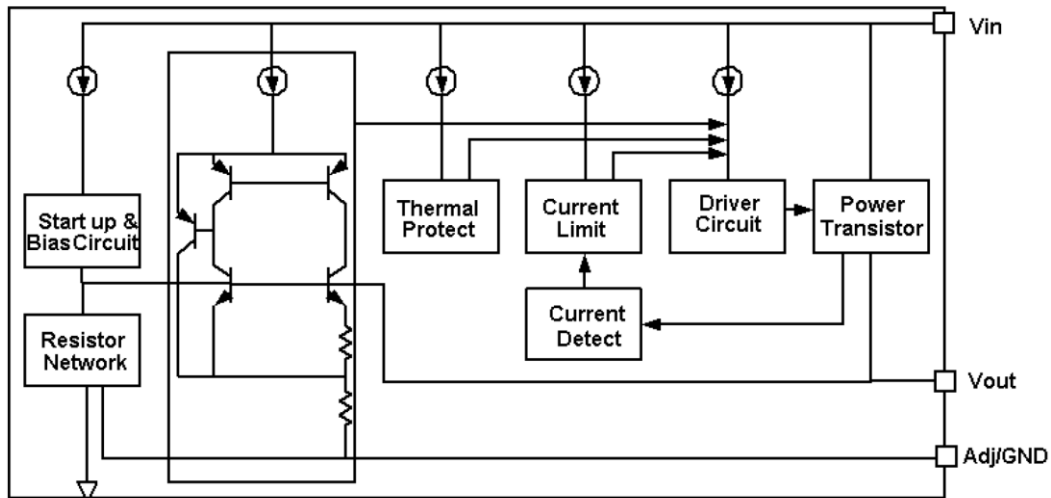

● **Pin Configuration**

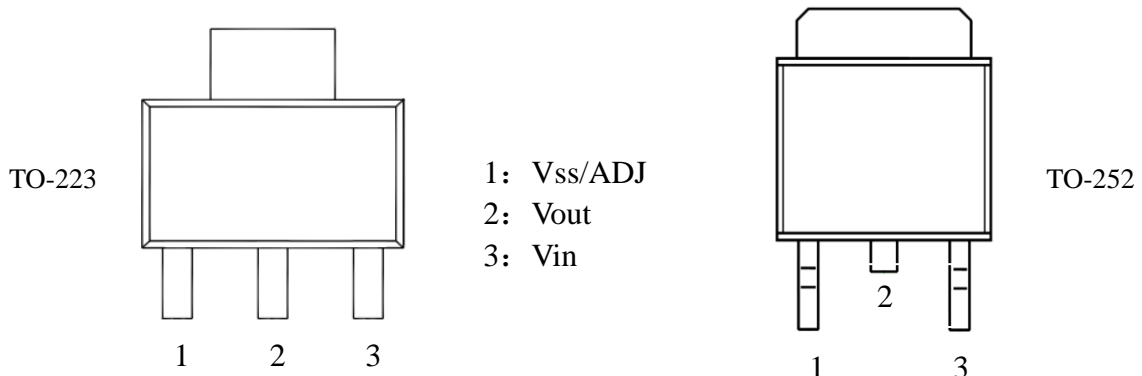

● **Absolute Maximum Rating**

Parameter	Value	
Max Input Voltage	15V	
Max Power Dissipation(Pd)	1.2 W	
Max Output Current	1A	
Recommended operating junction temperature(Tj)	-20~125°C	
Max Operating Junction Temperature(Tj)	150°C	
Ambient Temperature(Ta)	-40°C – 85°C	
Package Thermal Resistance	SOT-223	20°C / W
	TO-252	12.5°C / W
Storage Temperature(Ts)	-40°C - 150°C	
Lead Temperature & Time	260°C, 10S	

Caution: Exceed these limits to damage to the device. Exposure to absolute maximum rating conditions may affect device reliability.

Exceptional for AF1117A-12V, the maximum input voltage for AF1117A-12V is 20V.

● **Thermal Information**



# AF1117

Parameter	Package	Rating	Unit
Package thermal resistance	SOT-223	20	°C/W
	TO-252	12.5	°C/W

## ● Selection Table

Marking	Part No.	Output Voltage	Package
AF1117 XXX YYZZ	XX=1V2	1.2V	SOT-223 TO-252
	XXX=1V8	1.8V	
	XXX=2V5	2.5V	
	XXX=2V8	2.85V	
	XXX=3V3	3.3V	
	XXX=5V0	5.0V	
	XXX=ADJ	Adj	
	YYZZ	Date code	

## ● Ordering Information

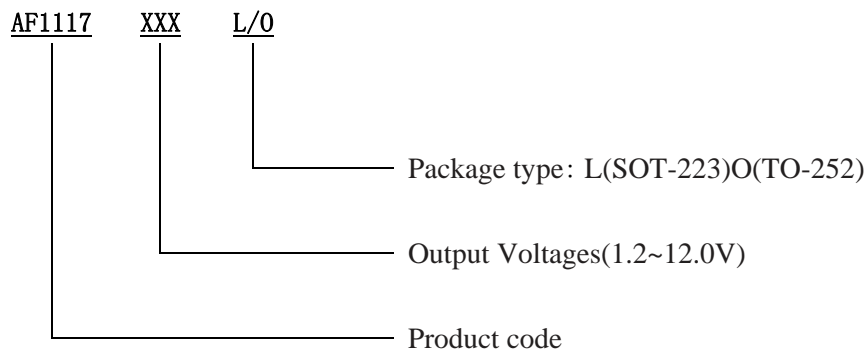

## ● Electrical Characteristics

Symbol	Parameter	Conditions	Min	Typ	Max	Unit
Vref	Reference voltage	AF1117-ADJ 10mA ≤ I <sub>out</sub> ≤ 1A, V <sub>in</sub> = 3.25V	1.225	1.25	1.275	V
Vout	Output voltage	AF1117-1.2V 0 ≤ I <sub>out</sub> ≤ 1A, V <sub>in</sub> = 3.2V	1.176	1.2	1.224	V
		AF1117-1.8V 0 ≤ I <sub>out</sub> ≤ 1A, V <sub>in</sub> = 3.8V	1.764	1.8	1.836	V
		AF1117-2.5V 0 ≤ I <sub>out</sub> ≤ 1A, V <sub>in</sub> = 4.5V	2.45	2.5	2.55	V
		AF1117-2.85V 0 ≤ I <sub>out</sub> ≤ 1A, V <sub>in</sub> = 4.85V	2.793	2.85	2.907	V



# AF1117

		AF1117-3.3V 0≤I <sub>out</sub> ≤1A, V <sub>in</sub> =5.3V	3.234	3.3	3.366	V
		AF1117-5.0V 0≤I <sub>out</sub> ≤1A, V <sub>in</sub> =7.0V	4.9	5	5.1	V
		AF1117-12.0V 0≤I <sub>out</sub> ≤1A, V <sub>in</sub> =14V	11.76	12	12.24	V
ΔV <sub>out</sub>	Line Regulation	AF1117-1.2V I <sub>out</sub> =10mA, 2.7V≤V <sub>in</sub> ≤10V		0.03	0.2	%/V
		AF1117-ADJ I <sub>out</sub> =10mA, 2.75V≤V <sub>in</sub> ≤12V		0.03	0.2	%/V
		AF1117-1.8V I <sub>out</sub> =10mA, 3.3V≤V <sub>in</sub> ≤12V		0.03	0.2	%/V
		AF1117-2.5V I <sub>out</sub> =10mA, 4.0V≤V <sub>in</sub> ≤12V		0.03	0.2	%/V
		AF1117-2.85V I <sub>out</sub> =10mA, 4.35V≤V <sub>in</sub> ≤12V		0.03	0.2	%/V
		AF1117-3.3V I <sub>out</sub> =10mA, 4.8V≤V <sub>in</sub> ≤12V		0.03	.2	%/V
		AF1117-5.0V I <sub>out</sub> =10mA, 6.5V≤V <sub>in</sub> ≤12V		0.03	0.2	%/V
ΔV <sub>out</sub>	Load regulation	AF1117-1.2V V <sub>in</sub> =2.7V, 10mA≤I <sub>out</sub> ≤1A		2	8	mV
		AF1117-ADJ V <sub>in</sub> =2.75V, 10mA≤I <sub>out</sub> ≤1A		2	8	mV
		AF1117-1.8V V <sub>in</sub> =3.3V, 10mA≤I <sub>out</sub> ≤1A		3	12	mV
		AF1117-2.5V V <sub>in</sub> =4.0V, 10mA≤I <sub>out</sub> ≤1A		4	16	mV
		AF1117-2.85V V <sub>in</sub> =4.35V, 10mA≤I <sub>out</sub> ≤1A		5	20	mV
		AF1117-3.3 V <sub>in</sub> =4.8V, 10mA≤I <sub>out</sub> ≤1A		6	24	mV
		AF1117-5.0 V <sub>in</sub> =6.5V, 10mA≤I <sub>out</sub> ≤1A		9	36	mV
V <sub>drop</sub>	Dropout voltage	I <sub>out</sub> =100mA		1.23	1.3	V
		I <sub>out</sub> =1A		1.3	1.5	V
I <sub>limit</sub>	Current limit	V <sub>in</sub> -V <sub>out</sub> =2V; T <sub>j</sub> =25°C	1.1	1.2		A
I <sub>min</sub>	Minimum load current	AF1117-ADJ		2	10	mA
I <sub>q</sub>	Quiescent Current	AF1117-1.2V, V <sub>in</sub> =10V		2	5	mA
		AF1117-1.8V, V <sub>in</sub> =12V		2	5	mA

		AF1117-2.5V, Vin=12V		2	5	mA
		AF1117-2.85V, Vin=12V		2	5	mA
		AF1117-3.3V, Vin=12V		2	5	mA
		AF1117- .0V, Vin=12V		2	5	mA
IAdj	Adjust pin current	AF1117-ADJ Vin=5V, 10mA ≤ Iout ≤ 1A		55	120	uA
PSRR	1117	f=100Hz, Cout=104		-65		dB
		f=1KHz, Cout=104		-65		dB
		f=10KHz, Cout=104		-60		dB
		f=22KHz, Cout=104		-57		dB
Ichange	Iadj change	AF1117-ADJ Vin=5V, 10mA ≤ Iout ≤ 1A		0.2	10	uA
ΔV/ΔT	Temperature coefficient			±100		ppm
θ <sub>JC</sub>	Thermal resistance	SOT-223		20		°C/W
		TO-252		12.5		

Note1: All test are conducted under ambient temperature 25 °C and within a short period of time 20ms

Note2: Load current smaller than minimum load current of AF1117-ADJ will lead to unstable or oscillation output.

## ● Detailed Description

AF1117 is a series of low dropout voltage, three terminal regulators. Its application circuit is very simple: the fixed version only needs two capacitors and the adjustable version only needs two resistors and two capacitors to work. It is composed of some modules including start-up circuit, bias circuit, bandgap, thermal shutdown, current limit, power transistors and its driver circuit and so on.

The thermal shut down modules can assure chip and its application system working safety when the junction temperature is larger than 140 °C.

The bandgap module provides stable reference voltage, whose temperature coefficient is compensated by careful design considerations. The temperature coefficient is under 100 ppm/°C. And the accuracy of output voltage is guaranteed by trimming technique.

## ● Typical Application

AF1117 has an adjustable version and six fixed versions (1.2V, 1.8V, 2.5V, 2.85V, 3.3V and 5V)

### Fixed Output Voltage Version

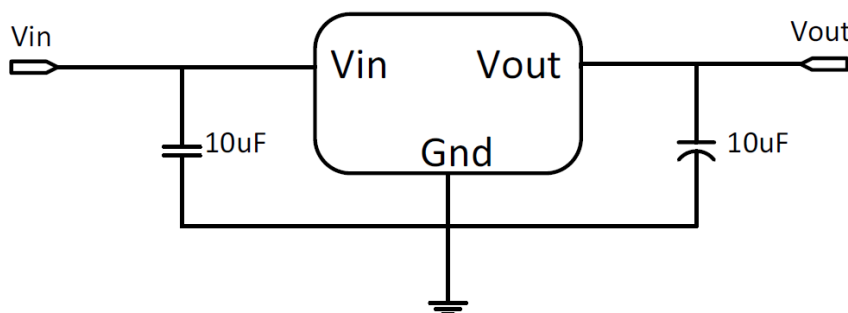

### Application circuit of AF1117 fixed version

- 1) Recommend using 10uF tan capacitor as bypass capacitor (C1) for all application circuit.
- 2) Recommend using 10uF tan capacitor to assure circuit stability.

### ● Adjustable Output Voltage Version

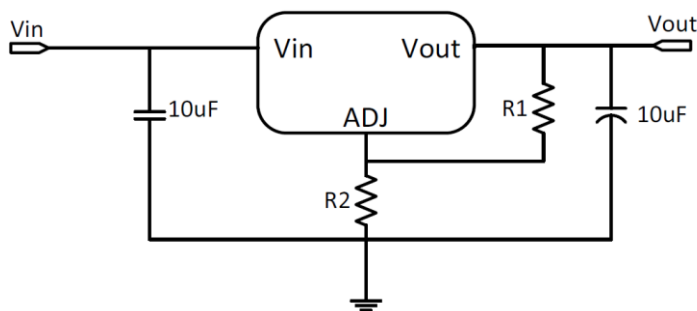

Application Circuit of AF1117-ADJ

The output voltage of adjustable version follows the equation:  $V_{out} = 1.25 \times (1 + R_2/R_1) + I_{Adj} \times R_2$ . We can ignore  $I_{Adj}$  because  $I_{Adj}$  (about 50uA) is much less than the current of  $R_1$  (about 2~10mA).

- 1) To meet the minimum load current (>10mA) requirement,  $R_1$  is recommended to be 125ohm or lower. As AF1117-ADJ can keep itself stable at load current about 2mA,  $R_1$  is not allowed to be higher than 625ohm.
- 2) Using a bypass capacitor ( $C_{ADJ}$ ) between the ADJ pin and ground can improve ripple rejection. This bypass capacitor prevents ripple from being amplified as the output voltage is increased. The impedance of  $C_{ADJ}$  should be less than  $R_1$  to prevent ripple from being amplified. As  $R_1$  is normally in the range of 100Ω~500Ω, the value of  $C_{ADJ}$  should satisfy this equation:  $1/(2\pi \times \text{fripple} \times C_{ADJ}) < R_1$ .

### ● Thermal Considerations

We have to take heat dissipation into great consideration when output current or differential voltage of input and output voltage is large. Because in such cases, the power dissipation consumed by AF1117 is very large. AF1117 series uses SOT-223 package type and its thermal resistance is about 20 °C/W. And the copper area of application board can affect the total thermal resistance. If copper area is 5cm\*5cm (two sides), the resistance is about 30 °C/W. So the total thermal resistance is about 20 °C/W + 30 °C/W. We can decrease total thermal resistance by increasing copper area in application board. When there is no good heat dissipation copper area in PCB, the total thermal resistance will be as high as 120 °C/W, then the power dissipation of AF1117 could allow on itself is less than 1W. And furthermore, AF1117 will work at junction temperature higher than 125 °C under such condition and no lifetime is guaranteed.

- **Typical Performance Characteristics**

T=25 °C unless specified.

### Line Regulation

AF1117-ADJ Vout Vs. Vin

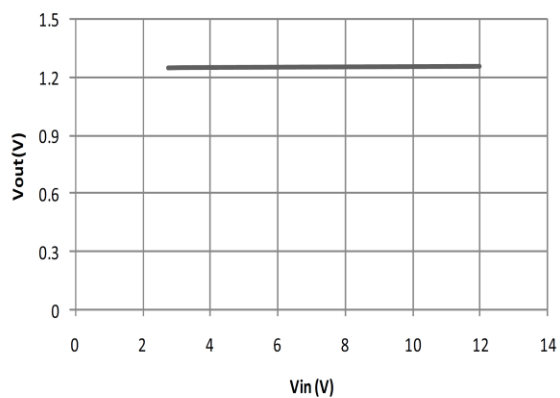

### Load Regulation

AF1117-ADJ Vout Vs. Iout

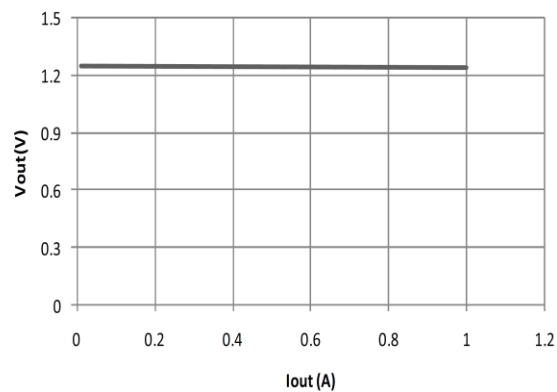

### Dropout Voltage

AF1117-ADJ Dropout Vs. Iout

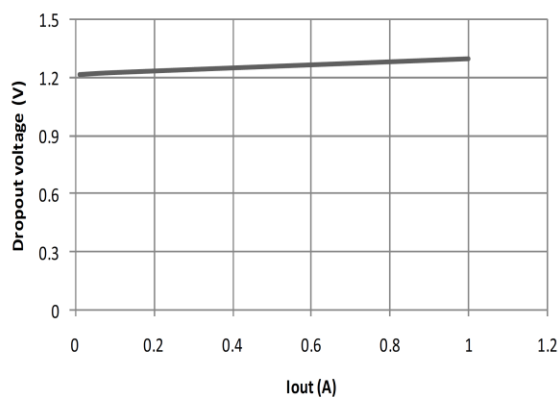

### Thermal performance with OTP

AF1117-ADJ Vout Vs. Temp

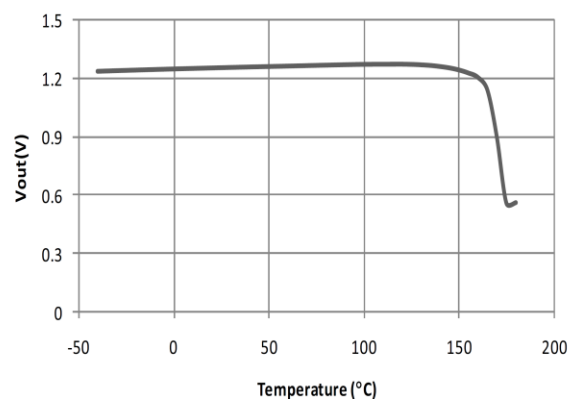

● **Package Information**

SOT-223

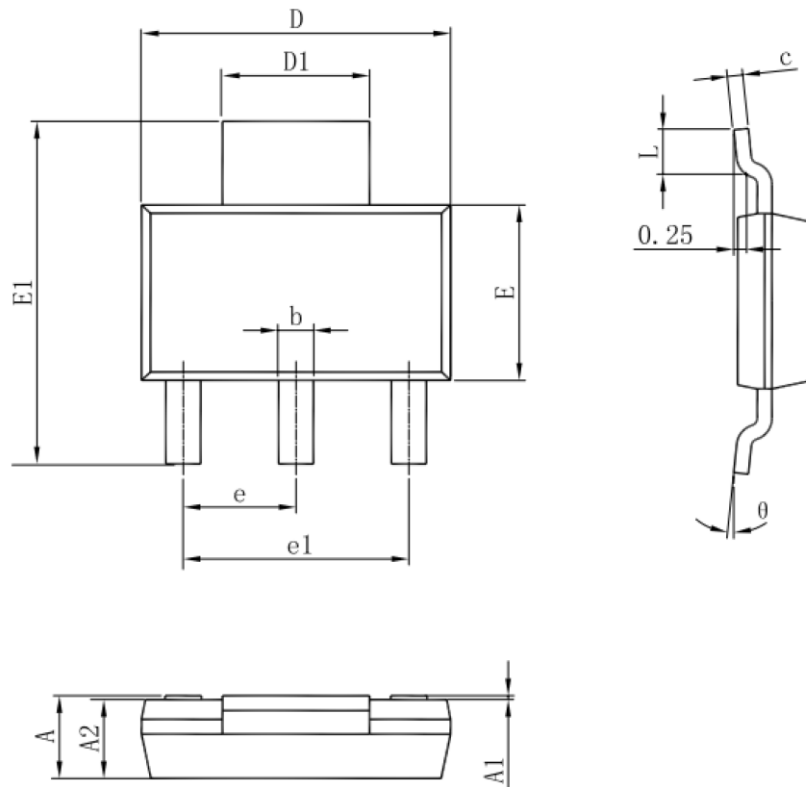

Symbol	Dimensions In Millimeters		Dimensions In Inches	
	Min	Max	Min	Max
A	1.520	1.800	0.060	0.071
A1	0.000	0.100	0.000	0.004
A2	1.500	1.700	0.059	0.067
b	0.660	0.820	0.026	0.032
c	0.250	0.350	0.010	0.014
D	6.200	6.400	0.244	0.252
D1	2.900	3.100	0.114	0.122
E	3.300	3.700	0.130	0.146
E1	6.830	7.070	0.269	0.278
e	2.300(BSC)		0.091(BSC)	
e1	4.500	4.700	0.177	0.185
L	0.900	1.150	0.035	0.045
$\theta$	0°	10°	0°	10°



TO-252-2L

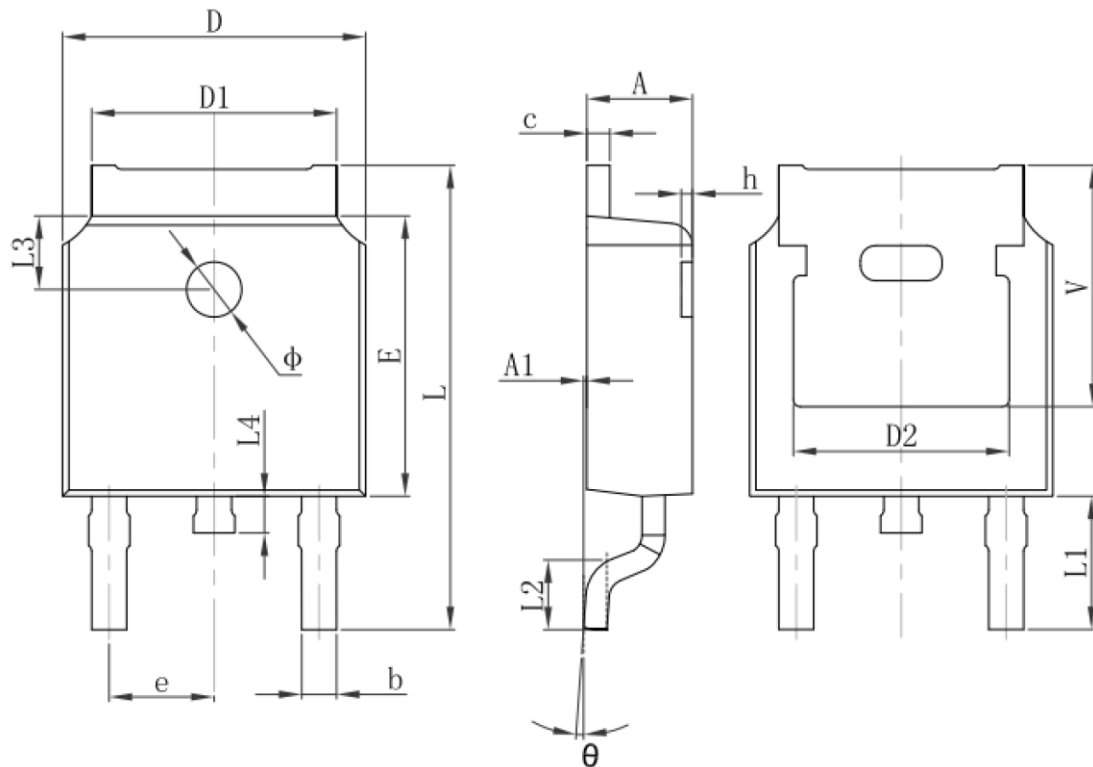

Symbol	Dimensions In Millimeters		Dimensions In Inches	
	Min.	Max.	Min.	Max.
A	2.200	2.400	0.087	0.094
A1	0.000	0.127	0.000	0.005
b	0.660	0.860	0.026	0.034
c	0.460	0.580	0.018	0.023
D	6.500	6.700	0.256	0.264
D1	5.100	5.460	0.201	0.215
D2	4.830 REF.		0.190 REF.	
E	6.000	6.200	0.236	0.244
e	2.186	2.386	0.086	0.094
L	9.800	10.400	0.386	0.409
L1	2.900 REF.		0.114 REF.	
L2	1.400	1.700	0.055	0.067
L3	1.600 REF.		0.063 REF.	
L4	0.600	1.000	0.024	0.039
$\Phi$	1.100	1.300	0.043	0.051
$\theta$	0°	8°	0°	8°
h	0.000	0.300	0.000	0.012
V	5.350 REF.		0.211 REF.	



## DISCLAIMER

AFSEMI RESERVES THE RIGHT TO MAKE CHANGES WITHOUT FURTHER NOTICE TO ANY PRODUCTS HEREIN TO IMPROVE RELIABILITY, FUNCTION OR DESIGN. AFSEMI DOES NOT ASSUME ANY LIABILITY ARISING OUT OF THE APPLICATION OR USE OF ANY PRODUCT OR CIRCUIT DESCRIBED HEREIN; NEITHER DOES IT CONVEY ANY LICIENCE UNDER ITS PATENT RIGHTS, NOR THE RIGHTS OF OTHERS.

THE GRAPHS PROVIDED IN THIS DOCUMENT ARE STATISTICAL SUMMARIES BASED ON A LIMITED NUMBER OF SAMPLES AND ARE PROVIDED FOR INFORMATIONAL PURPOSE ONLY. THE PERFORMANCE CHARACTERISTICS LISTED IN THEM ARE NOT TESTED OR GUARANTEED. IN SOME GRAPHS, THE DATA PRESENTED MAY BE OUTSIDE THE SPECIFIED OPERATING RANGE (E.G., OUTSIDE SPECIFIED POWER SUPPLY RANGE ) AND THEREFORE OUTSIDE THE WARRANTED RANGE.