



General Description

The AF1117 series of positive adjustable regulators are designed to provide 1A with high efficiency. All internal circuitry is designed to operate down to 1.4V input to output differential.

On-chip trimming adjusts the reference voltage to 1%. Current limit the typical value of 1.5A allows to minimize the stress on both the regulator and the power source circuitry under overload conditions.

Features

- ◆ Adjustable Output
- ◆ Output Current of 1A
- ◆ Low Dropout, 1.3 V typ. at 1A Output Current
- ◆ 0.04% Line Regulation
- ◆ 0.2 % Load Regulation
- ◆ 100% Thermal Limit Burn-In
- ◆ Fast Transient Response

Application

- High Efficiency Linear Regulators
- Post Regulators for Switching Supplies
- Adjustable Power Supply

Pin Define

SOT-223

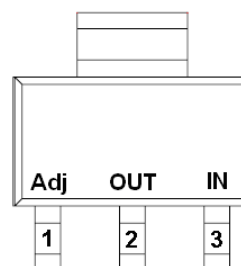

Marking Information

SOT-223

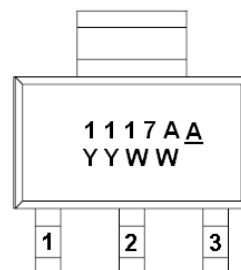



Block Diagram

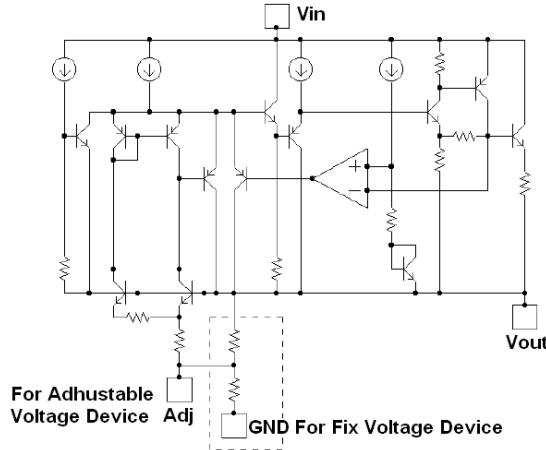

Typical Application Circuit

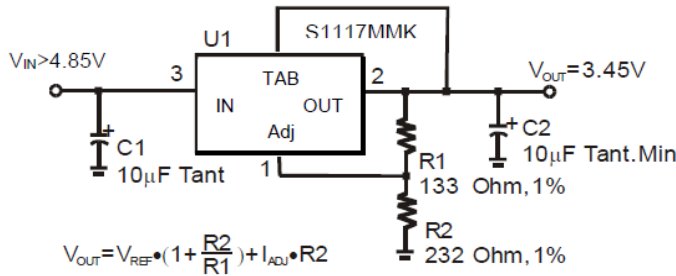

- Notes:
 1) C1 needed if device is far from filter capacitors
 2) C2 minimum value required for stability

Pin Description (SOT-223)

Pin	Symbol	Description
1	Adj	Adjust Vout
2	OUT	Voltage Output
3	IN	Voltage Input

Ordering Information

Part Number	Package	Output Voltage	Part Marking	Unit	Quantity
AF1117AS223RG-ADJ	SOT-223	Adj	1117AA	Tape & Reel	2500 EA

- ※ 1117A parts code
- ※ A voltage code
- ※ YY year code
- ※ WW week code
- ※ AF1117AS223RG : 13" Tape & Reel ; Pb- Free ; Halogen -Free



Absolute Maximum Ratings ($T_A=25^\circ\text{C}$ Unless otherwise noted)

Symbol	Parameter	Value	Units
P_D	Power Dissipation	Internally Limited	W
V_{IN}	Input Voltage	20	V
T_J	Operating Junction Temperature Range	-40 to 125	$^\circ\text{C}$
T_{STG}	Storage Temperature	-65 to 150	$^\circ\text{C}$
T_{LEAD}	Lead Temperature (Soldering, 10 sec)	300	$^\circ\text{C}$
V_{ESD}	Minimum ESD Rating (HBM)	3	kV

AF1117AS223RG-ADJ Electrical Characteristics

($T_J = 25^\circ\text{C}$, and apply over the full operating Temperature Range)

Parameter	Device	Test Conditions	Min	Typ	Max	Units
Reference Voltage Note 1	AF1117-ADJ	$V_{IN}=5V, I_{LOAD}=10\text{mA}$ $1.5V \leq V_{IN}, V_{OUT} \leq 10V$ $I_{LOAD}=10\text{mA to }1A$	1.232	1.250	1.268	V
Output Voltage Note 1	$V_{out} = 1.2V$	$1.5V \leq V_{IN}, V_{OUT} \leq 10V$ $I_{LOAD} = 0\text{ mA to }1A,$ Variator from nominal V_{OUT}	-3		+2	%
Accurace output Voltage, at wafer testing	AF1117-ADJ	$V_{IN} = V_{OUT} + 1.5V$ $I_{LOAD} = 10\text{ mA}$	-0.6%	0	+0.6%	%
Line Regulation	AF1117-ADJ	$I_{LOAD} = 10\text{ mA}, 1.5V \leq V_{IN}, V_{OUT} \leq 10V$		0.04	0.20	%
Load Regulation Note 1	AF1117-ADJ	$V_{IN} = V_{OUT} + 1.5V$ $I_{LOAD} = 10\text{ mA to }1A$		0.2	0.40	
Minimum Load Current	AF1117-ADJ	$V_{IN} = 5V, V_{ADJ} = 0V$		2	7	mA
Adjust Pin Current	AF1117-ADJ	$1.5V \leq V_{IN}, V_{OUT} \leq 10V$ $I_{LOAD} = 10\text{ mA}$		35	60	μA
Current Limit	AF1117-ADJ	$(V_{IN} - V_{OUT}) = 1.5\text{ V}$	1	1.5	2	A
Ripple Rejection Note 2	AF1117-ADJ	$V_{IN} - V_{OUT} = 2.5\text{ V}$ $I_{LOAD} = 1A$	60			dB
Dropout Voltage Note 1,3	AF1117-ADJ	$I_{LOAD} = 1A$		1.20	1.40	V
Temperature coefficient	AF1117-ADJ	$V_{IN} - V_{OUT} = 1.5\text{ V}, I_{LOAD} = 10\text{ mA}$			0.015	$\%/^\circ\text{C}$

The * denotes the specifications which apply over the full temperature range – $40^\circ\text{C} \leq T_J \leq 125^\circ\text{C}$

Note 1: Low duty pulse testing with Kelvin connections required.

Note 2: 120Hz input ripple (C_{ADJ} for ADJ=25 μF)

Note 3: $\Delta V_{OUT}, \Delta V_{REF} = 1\%$



Package Information (SOT-223)

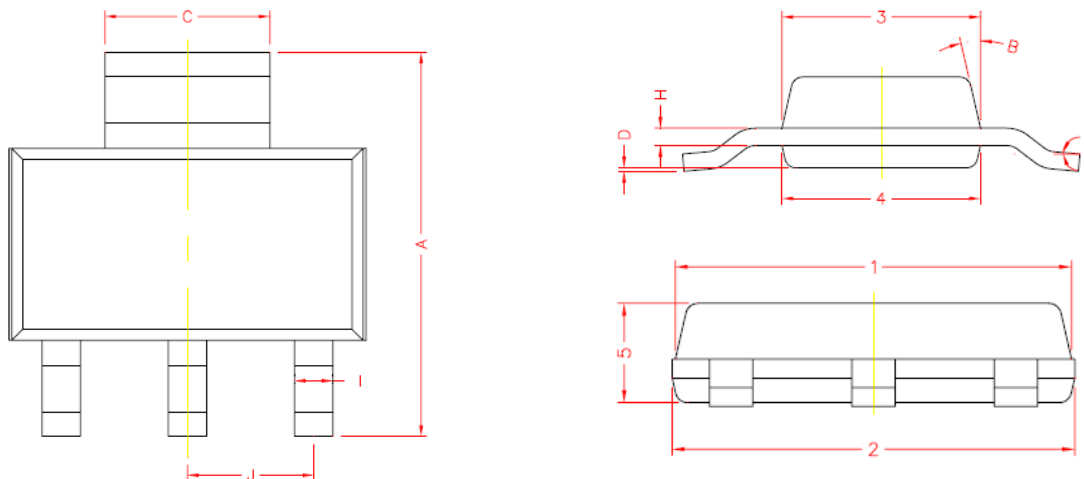

REF.	DIMENSIONS	
	Millimeters	
	Min.	Max.
A	6.70	7.30
C	2.90	3.10
D	0.02	0.10
E	0*	10*
I	0.60	0.80
H	0.25	0.35
B	13* TYP.	
J	2.30 REF.	
1	6.30	6.70
2	6.30	6.70
3	3.30	3.70
4	3.30	3.70
5	1.40	1.80

©2010 Alfa-MOS Technology Corp.
 2F, No.80, Sec.1, Cheng Kung Rd., Nan Kang Dist., Taipei City 115, Taiwan (R.O.C.)
 Tel : 886 2) 2651 3928
 Fax : 886 2) 2786 8483
 ©http://www.alfa-mos.com