



General Description

The AF1820 is a TRIAC and multi-steps dimmable simplest current injected topology control IC for isolation LED driver that had some characteristics, the first is operating without electrolytic capacitors which is necessary for the DC power supply structure, the second is operating without photo coupler and the last is enhancing the power factor to larger than 90%.

Eliminating the electrolytic capacitor in the LED lighting driver could fulfill the long life time and high efficiency of the lamps.

Eliminating the photo coupler in the light load LED lighting driver could save the power which is larger than 0.75W for 500mA LED current. (reference voltage 2.5v × 0.5A LED current = 1.25W); for a 10W LED application, this could lose 12.5% efficiency at least.

Moreover, with eliminating electrolytic capacitors and photo coupler could reduce the cost for the LED driver.

Features

- Without electrolyte capacitor
- No photo coupler
- PWM frequency jittering to reduce EMI noise
- HV Start-up circuit eliminates outer resistor and reduce input power consumption
- Constant current (RMS) for LED
- Phase-controlled TRIAC Dimming
- Multi-steps dimming
- Integrated Over Current Protection (OCP)
- Embedded Leading Edge Blanking (LEB)
- Integrated Over Voltage Protection (OVP)
- Integrated Thermal Shutdown (TSD)
- System efficiency >90% in simulation
- System PF >0.9 in simulation

Application

- LED lighting Driver
- OLED lighting Driver

Pin Define (SOP-8)

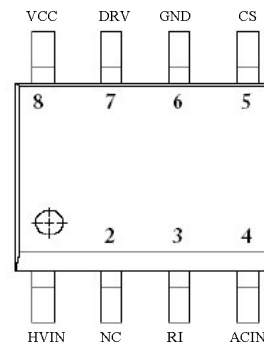

Marking Information





Typical Application Circuit

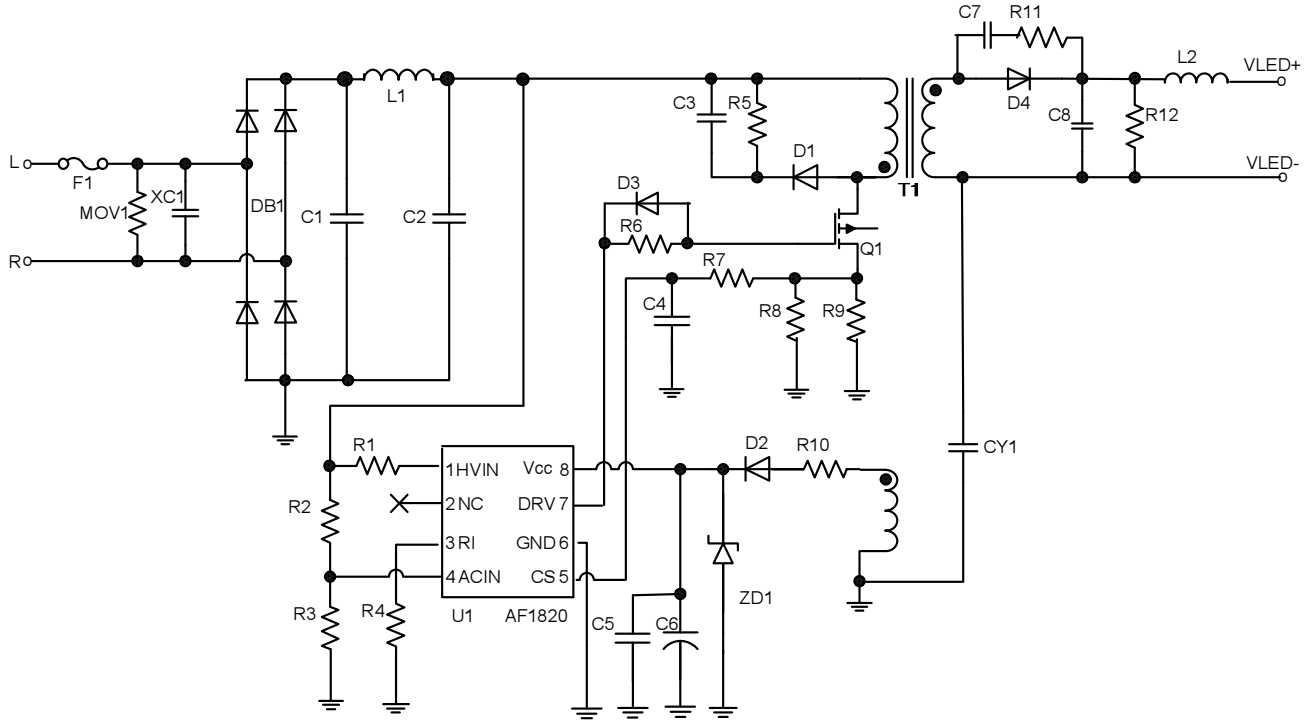

Pin Description

Pin	Symbol	Description
HVIN	1	Input for start-up current
NC	2	
RI	3	Sets the switching frequency
ACIN	4	Provides the sinusoidal ac input waveform
CS	5	Current sense resistor input
GND	6	Ground
DRV	7	Gate driver output for external MOSFET
VCC	8	IC power supply pin

Ordering Information

Part Ordering No.	Part Marking	Package	Unit	Quantity
AF1820S8RG	AF1820	SOP-8	Tape & Reel	2500 EA

- ※ A Lot code
- ※ B Date code
- ※ AF1820S8RG : 13" Tape & Reel ; Pb- Free ; Halogen- Free



Block Diagram

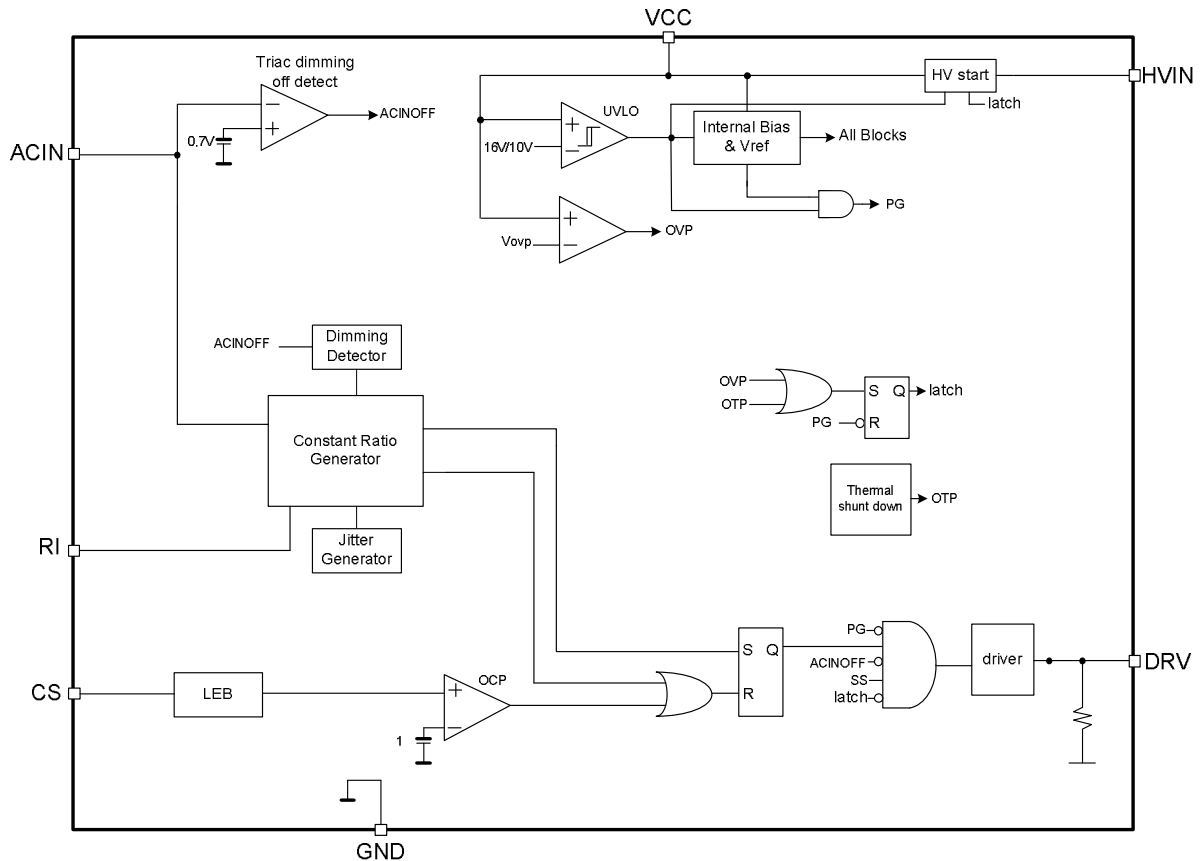

Absolute Maximum Ratings ($T_A=25^{\circ}\text{C}$ Unless otherwise noted)

The following ratings designate persistent limits beyond which damage to the device may occur.

Symbol	Parameter	Value	Unit
V_{CC}	Supply Voltage VCC	25	V
V_{CS}	CS pin voltage	5	V
V_{ACIN}	ACIN pin voltage	5	V
V_{HVIN}	HVIN	600	V
T_{OPR}	Operating Temperature Range	-20 to +125	$^{\circ}\text{C}$
T_{STG}	Storage Temperature Range	-40 to +150	$^{\circ}\text{C}$

Caution:

1. The absolute maximum ratings are rated values exceeding which the product could suffer physical damage. These values must therefore not be exceeded under any conditions.



Electrical Characteristics

($T_A=25^{\circ}\text{C}$, $V_{CC}=15\text{V}$, unless otherwise specified.)

Symbol	Parameter	Conditions	Min.	Typ.	Max.	Unit
● High-Voltage Supply						
	High-Voltage Current Source	$V_{CC} < UVLO(\text{on})$, HV=500V	1	1.2	1.5	mA
	Off-State Leakage Current	$V_{CC} > UVLO(\text{off})$, HV=500V			35	uA
● Supply Voltage						
VCC	Operating range	After turn-on	10		22	V
VCCon	Turn-on threshold		15	16	17	V
VCCoff	Turn-off threshold		9	10	11	V
Vovp	OVP Level		24.5	26	27.5	V
Vlatch	VCC latch voltage			12		V
● Supply Current						
Istart-up	Startup Current (HV start)	Before turn-on, $V_{CC}=15\text{V}$	1	1.2	1.5	mA
Iq	Quiescent Current	After turn-on		2.5		mA
Icc	Operating Supply Current	@ 75KHz		3		mA
Iqp	Quiescent Current when latch	During latch protection		0.5		mA
● Current Sensing						
Vcsmax	Maximum Input Voltage	OCP		1		V
tLEB	Leading Edge Blanking Time			300		ns
td(H-L)	Delay to Output			150		ns
● Gate Drive Output						
Tr	Voltage Rising Time	Load Capacitance=1000pF		150		ns
Tf	Voltage Falling Time	Load Capacitance=1000pF		50		ns
● Thermal Shutdown (TSD)						
T _{TSD}			140			°C
● Jitter						
Del_F	Oscillator Frequency Modulation		+/-8.5%			Del_F
● Dimming Function						
VACIN_off	Triac dimming off detect			0.7		v



Application Information

Simplest Current Injected Topology

After bridge rectifier, there is a constant output power by constant duty and switching frequency. The output current I_{SEC} from the transformer, as shown in Fig.1 and Fig.2, there is an inductance to smooth the output current I_{SEC} for the LED current I_{LED} as shown in Fig.3. We call it current injected for the I_{LED} is transporting directly from the AC Line. Therefore, there is no electrolyte capacitor to regulate the output voltage; moreover, there do not need the photo coupler to control the power supply by constant output power.

Setting the switching frequency by tuning the resistance of the RI pin and the capacitance of the VTRI pin.

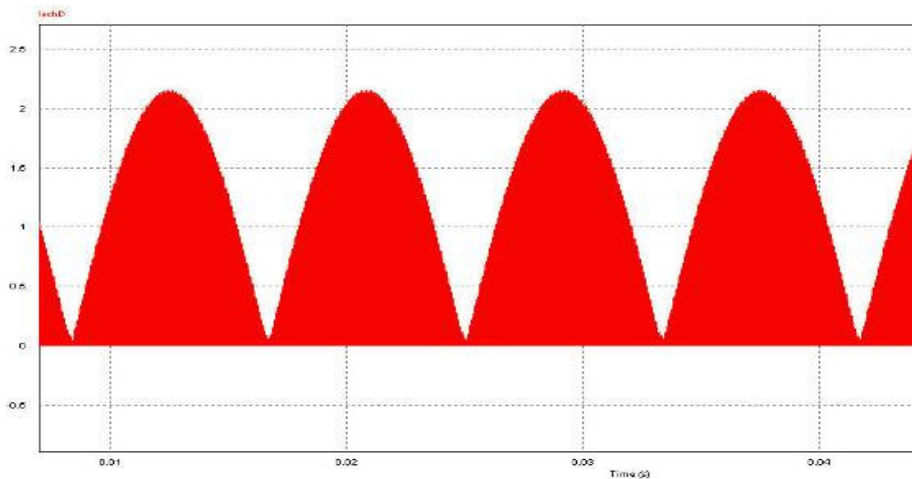

Fig.1

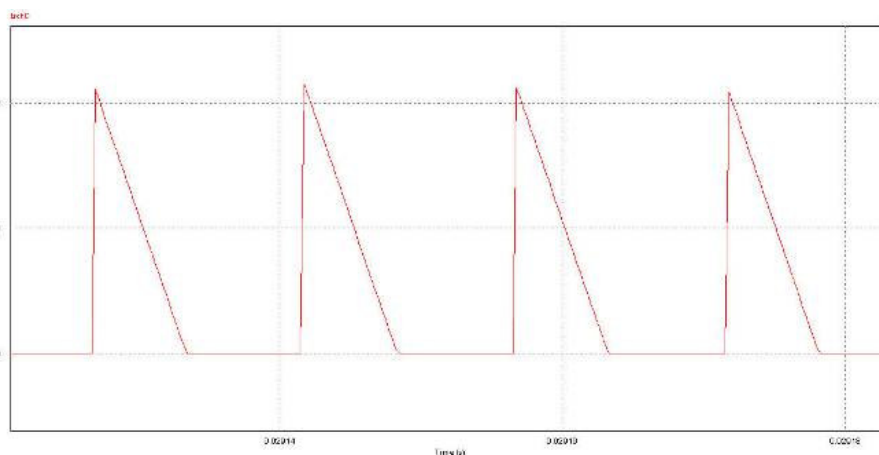

Fig.2

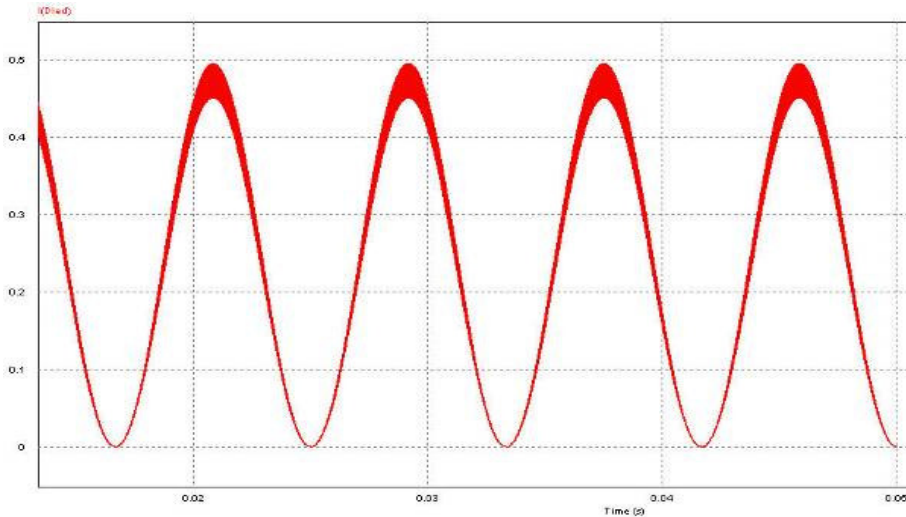

Fig.3

Multi- Steps Dimming Control

With the unique Dimming technology, Multi- steps Dimming Control(MSDC), the brightness is controllable.

Detecting the AC Line when there has the AC line switching within a short time in specification, the controller would switch the output power level by skipping duty. There are four steps output power level, 100%, 75%, 50% and 25% of the original setting.

Internal High-Voltage Startup Circuit and Under Voltage Lockout (UVLO)

Traditional circuits provide the startup current through a startup resistor to power up the PWM controller.

Nevertheless, it consumes power to meet the current power saving requirement. In most cases, startup resistors carry large resistance, which causes longer startup time. To achieve the optimized topology AF1820 is implemented with a high-voltage startup circuit for such requirement. During startup, a high-voltage current source sinks current from the bulk capacitor to provide the startup current as well as to charge the Vcc capacitor C1. During the startup transient when the Vcc is lower than the UVLO threshold, the high-voltage current source is enabled to supply about 1mA current. As the Vcc voltage rises higher than UVLO(on) to power on the AF1820 to deliver the gate drive signal, the high-voltage current source is disabled and the supply current is solely provided from the auxiliary winding of the transformer. Therefore, it eliminates the power loss on the startup circuit and performs highly power saving. An UVLO comparator is embedded to detect the voltage on the Vcc pin and to ensure the supply voltage high enough to power on the AF1820 PWM controller and to drive the power MOSFET. As shown in Fig. 4 and Fig.5, a hysteresis is provided to prevent undesired shutdown from the voltage dip during startup. The turn-on and turn-off threshold levels are set at 16V and 10V, respectively.



The start-up time is decided to capacity connected Vcc pin, can demand it by next type.

$$T_{START} = C \times (V_{CC(ON)} - V_{CC(int)}) / I_{STARTUP}$$

※TSTART : Start-up time [S], VCC(int) : VCC initial voltage [V], C : Capacity connected Vcc pin[F]

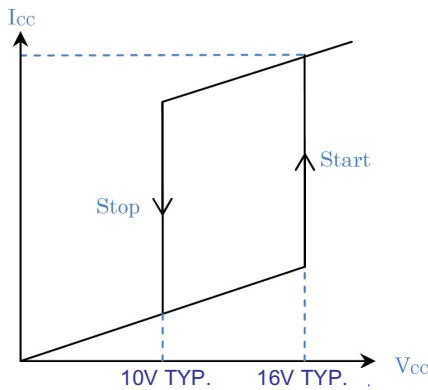

Fig.4

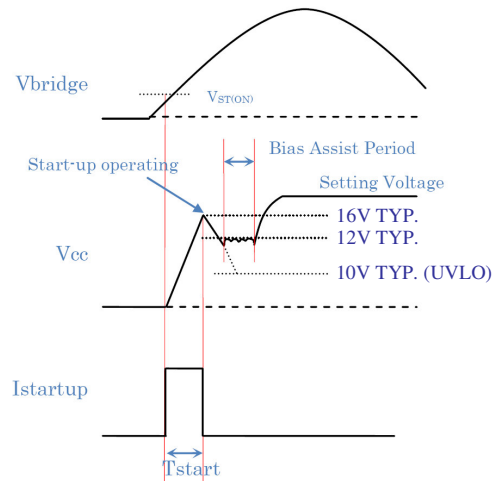

Fig.5

Current Sensing, Leading-Edge Blanking and the Negative Spike on CS Pin

The typical current mode PWM controller feeds back both current signal and voltage signal to close the control loop and achieve regulation. The AF1820 series detects the primary MOSFET current from the CS pin, which is not only for the peak current mode control but also for the pulse-by-pulse current limit. The maximum voltage threshold of the current sensing pin is set at 1V. Thus the MOSFET peak current can be calculated as:

$$I_{Peak(Max)} = \frac{1V}{R_s}$$

A 230nS leading-edge blanking (LEB) time is provided in the input of CS pin to prevent false-triggering from a current spike. In low power applications, if the total pulse width of the turn-on spikes is less than 230nS and the negative spike on the CS pin does not exceed -0.3V, the R-C filter (as shown in Fig.6) can be eliminated. However, the total pulse width of the turn-on spike is related to output power, circuit design and PCB layout. It is strongly recommended to add a small R-C filter (as shown in Fig.7) for higher power applications to avoid the CS pin from being damaged by the negative turn-on spike.

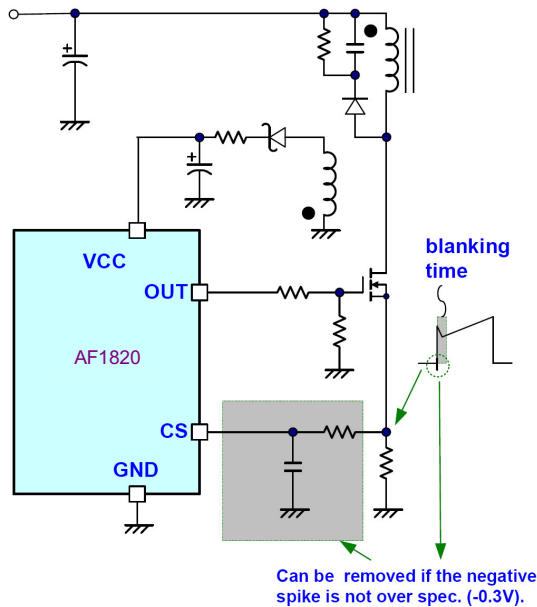

Fig.6

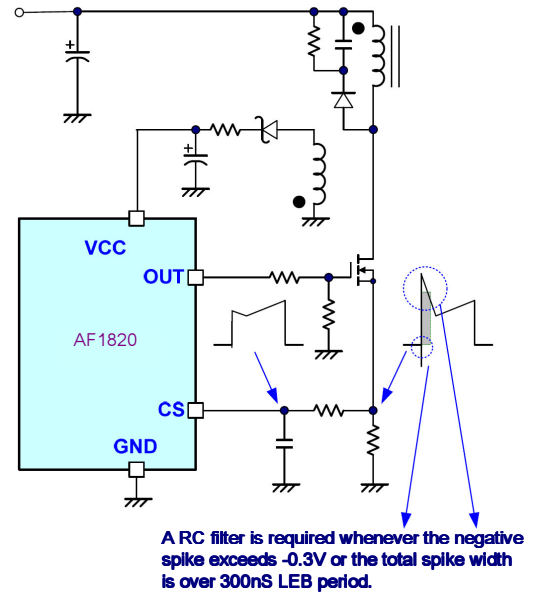

Fig.7

Latch Function

The latch circuit is stopped switching when OVP circuit and TSD circuit operated each and it protects the IC by keeping the stop state.

This circuit makes the delay time to prevent an irregular operation by noises and operates in the case of following to protect more than a constant time.

When the IC stops switching by this circuit, Vcc terminal voltage begins falling down. when Vcc terminal voltage falled down to 12V typical, it supplies start-up current in

Vcc terminal. and it keeps the latch state to prevent falling down to 10V typical.

The latch cancellation turns off AC input once basically and it is canceled by falling Vcc terminal voltage to less than 10V typical.

Thermal Shut Down Circuit

When the junction temperature of IC reaches to 140°C by rising of the ambient temperature, the latch circuit operates.

The real temperature detection goes in a control element.



Over Voltage Protection Circuit

When the power supply IC became the no load state in constant current control, it become uncontrollable and occur to overvoltage in output. With it, the Vcc terminal voltage rises too. Shown in Fig.8 is OVP circuit sequence. The IC have the over voltage protection function built-in to protect output and load from overvoltage. The IC does not directly monitor, but it protects load by monitoring Vcc terminal voltage. In other words, the latch circuit operates and stops switching when Vcc terminal voltage exceed 25V typical.

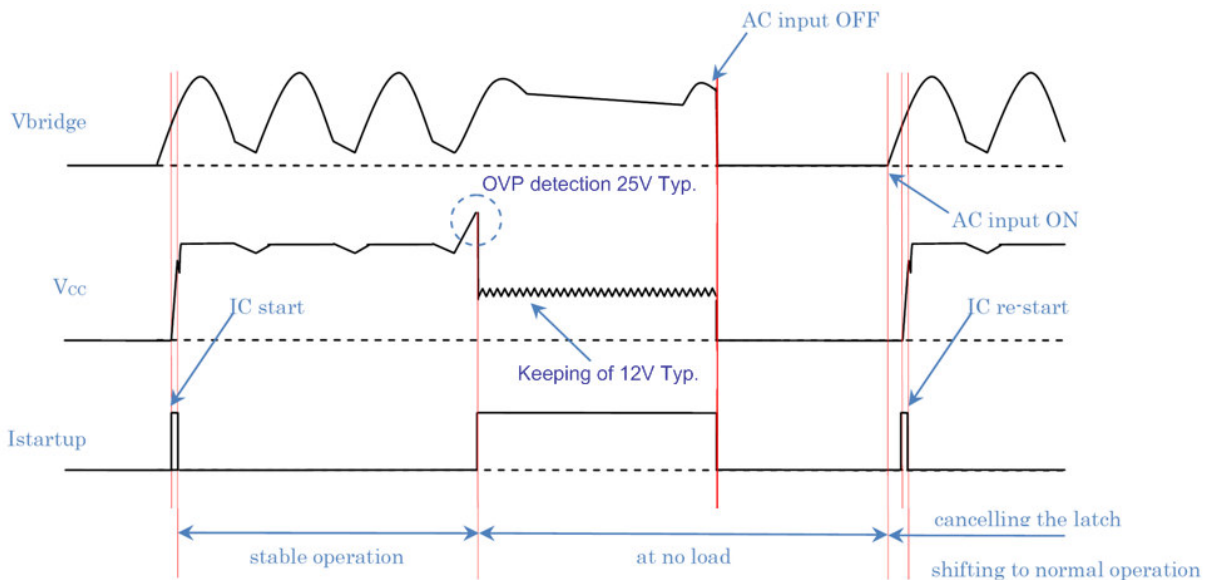
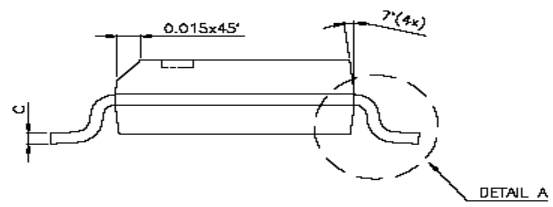
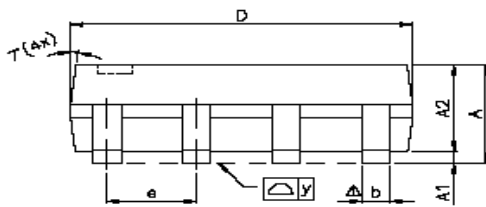
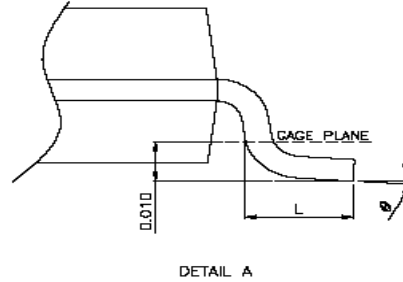
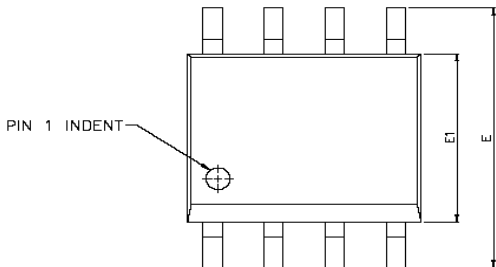

Fig.8



Package Information (SOP-8)



SYMBOLS	DIMENSIONS IN MILLIMETERS			DIMENSIONS IN INCHES		
	MIN	NOM	MAX	MIN	NOM	MAX
A	1.47	1.60	1.73	0.058	0.063	0.068
A1	0.10	—	0.25	0.004	—	0.010
A2	—	1.45	—	—	0.057	—
b	0.33	0.41	0.51	0.013	0.016	0.020
C	0.19	0.20	0.25	0.0075	0.008	0.0098
D	4.80	4.85	4.95	0.189	0.191	0.195
E	5.80	6.00	6.20	0.228	0.236	0.244
E1	3.80	3.90	4.00	0.150	0.154	0.157
e	—	1.27	—	—	0.050	—
L	0.38	0.71	1.27	0.015	0.028	0.050
Δ y	—	—	0.076	—	—	0.003
θ	0°	—	8°	0°	—	8°

©2010 Alfa-MOS Technology Corp.
 2F, No.80, Sec.1, Cheng Kung Rd., Nan Kang Dist., Taipei City 115, Taiwan (R.O.C.)
 Tel : 886 2) 2651 3928
 Fax : 886 2) 2786 8483
 ©http://www.alfa-mos.com