

1.1A Lithium Ion Battery Linear Charger

GENERAL DESCRIPTION

AF4057 is a complete CC/CV linear charger for single cell lithium-ion batteries. It is specifically designed to work within USB power Specifications.

No external sense resistor is needed and no blocking diode is required due to the internal P-MOSFET architecture. Thermal feedback regulates the charge current to limit the die temperature during high power operation or high ambient temperature. The charge voltage is fixed at 4.35V, and the charge current can be programmed externally with a single resistor. The AF4057 automatically terminates the charge cycle when the charge current drops to 1/10th the programmed value after the final float voltage is reached.

When the input supply (wall adapter or USB supply) is removed the AF4057 automatically enters a low current state dropping the battery drain current to less than 2 μ A. The AF4057 can be put into shutdown mode reducing the supply current to 55 μ A.

Other features include Battery temperature monitor, under-voltage lockout, automatic recharge and two status pins to indicate charge and charge termination.

Features

- Protection of battery cell reverse connection
- Programmable charge current up to 1.1A
- No MOSFET sense resistor or blocking diode required
- Complete linear Charger for single Cell Lithium-Ion Batteries
- CC and CV operation with thermal regulation to maximize Rate without risk of overheating
- Preset 4.35V charge voltage with $\pm 1\%$ accuracy
- Automatic Recharge
- Two Status Indication for Charge status, no battery and battery failure indicators
- C/10 charge termination
- 55 μ A supply current in shutdown
- 2.9V trickle current charge threshold
- Soft-Start limits inrush current
- Battery Temperature Sensing
- Available in ESOP-8 package

Applications

- Cellular Telephones
- Mobile Power Supply
- Digital Still Cameras
- MP3 Players
- Bluetooth Applications
- Portable Devices
- USB Bus-Powered Chargers

Typical Application

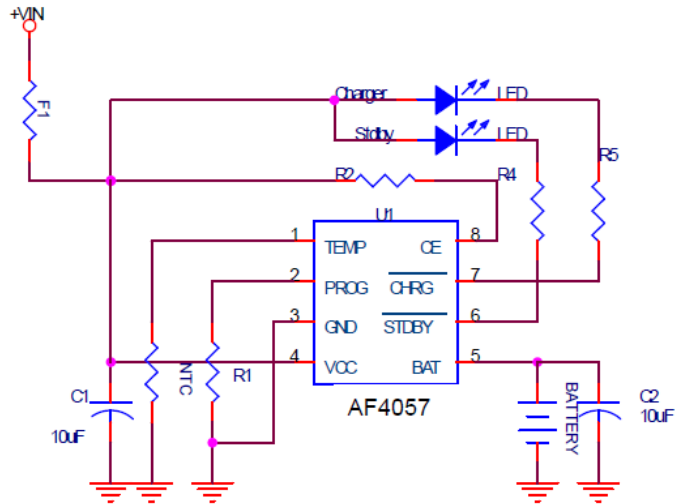

Pin Configuration

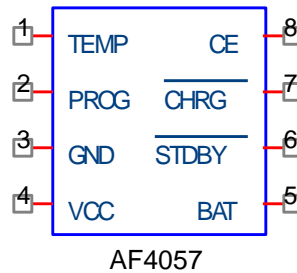

Typical charge cycle (1100 mAh Battery)

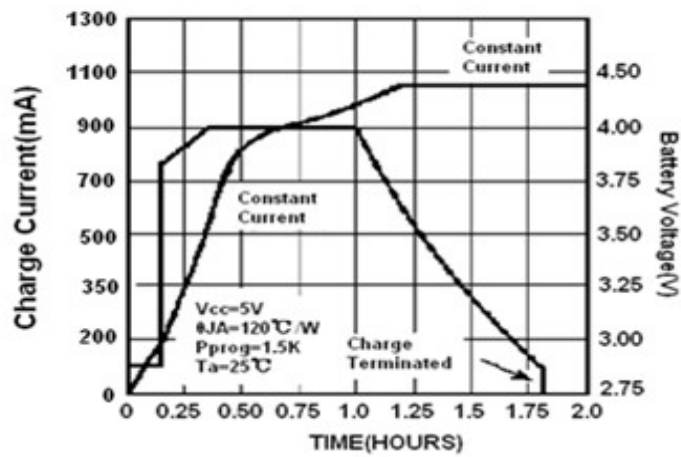

Pin Assignment

PIN Num.	Symbol	Function
1	TEMP	Temperature sense input Connecting TEMP pin to NTC thermistor's output in Lithium ion battery pack. If TEMP pin's voltage is below 45% or above 80% of supply voltage V_{CC} , this means that battery's temperature is too low or too high, charging is suspended. The temperature sense function can be disabled by grounding the TEMP pin.
2	PROG	Constant Charge Current Setting and Charge Current Monitor Pin The charge current is programmed by connecting a resistor R_{PROG} from this pin to GND. When in precharge mode, the PROG pin's voltage is regulated to 0.1V. When charging in constant-current mode this pin's voltage is regulated to 1V. In all modes during charging, the voltage on this pin can be used to measure the charge current using the following formula: $I_{PROG} = \frac{V_{PROG}}{R_{PROG}} \times 1200$
3	GND	Ground
4	VCC	Positive input supply voltage Provides power to the internal circuit. When V_{CC} drops to within 80mV of the BAT pin voltage, the AF4057 enters low power sleep mode, dropping I_{BAT} to less than 2 μ A.
5	BAT	Battery connection Pin Connect the positive terminal of the battery to this pin. Dropping BAT pin's current to less than 2 μ A when IC in disable mode or in sleep mode. BAT pin provides charge current to the battery and provides regulation voltage of 4.35V.
6	\overline{STDBY}	Charge terminated status output \overline{STDBY} is pulled low by an internal switch to indicate a battery charge terminated; this means Charge termination. Otherwise pin is in high impedance state.
7	\overline{CHRG}	Open-Drain charge status output When the battery is being charged, the \overline{CHRG} pin is pulled low by an internal switch, otherwise, \overline{CHRG} pin is in high impedance state.
8	CE	Chip enable input A high input will put the device in the normal operating mode. Pulling the CE pin to low level will put the AF 4057 into disable mode. The CE pin can be driven by TTL or CMOS logic level.

Block Diagram

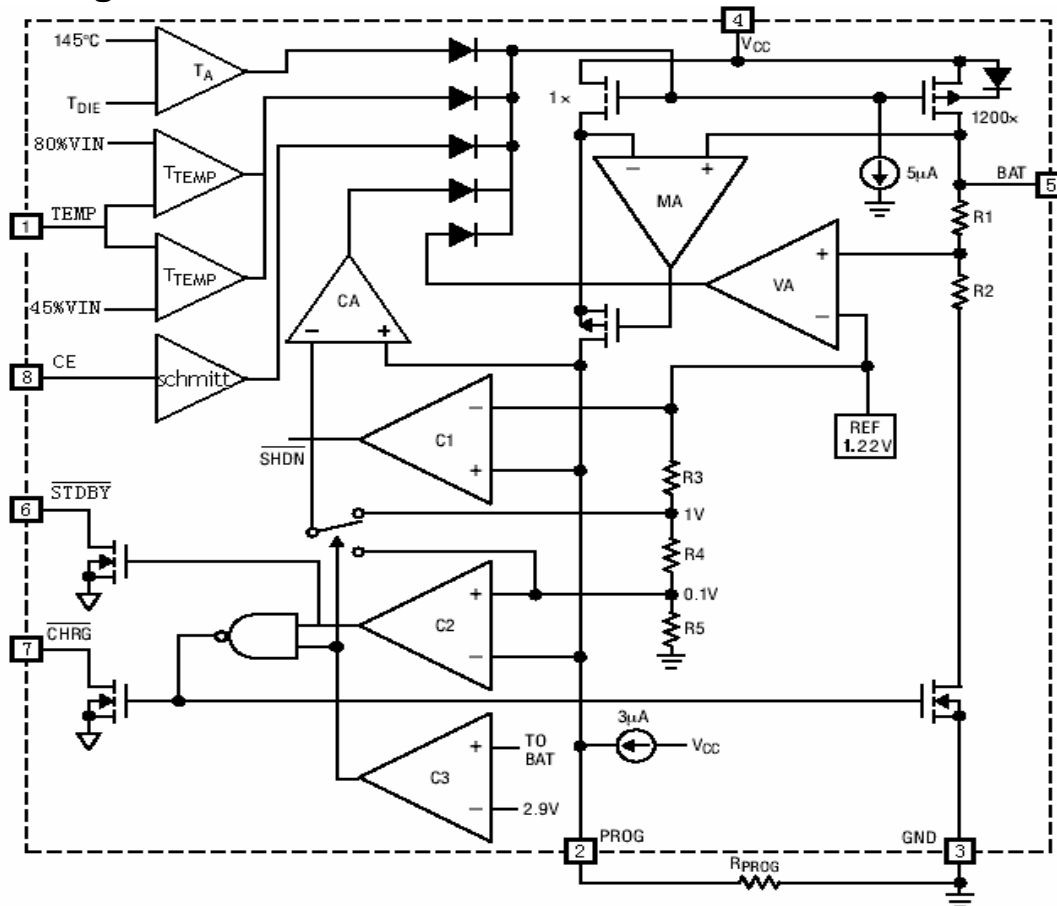

Absolute Maximum Ratings

Parameter	Rating	Unit
Input supply voltage : V _{CC}	-0.3~8	V
PROG pin voltage	-0.3~V _{CC} +0.3	V
BAT pin voltage	-0.3~7	V
TEMP pin voltage	-0.3~10	V
pin voltage	-0.3~10	V
pin voltage	-0.3~10	V
CE pin voltage	-0.3~10	V
BAT pin current	1200	mA
PROG pin current	1200	uA
Maximum junction temperature	150	°C
Operating ambient temperature	-40~85	°C
Storage temperature	-65~125	°C
Soldering temperature and time	+260 (Recommended 10S)	°C

Caution: The absolute maximum ratings are rated values exceeding which the product could suffer physical damage. These values must therefore not be exceeded under any conditions.

Electrical Characteristics

Symbol	Parameter	Test Condition	MIN	TPY	MAX	Unit
V _{CC}	Input supply voltage		4.0	5.0	8.0	V
I _{CC} -I _{BAT}	Static Current	Charge mode, R _{PROG} =1.2K		150	500	uA
		Standby mode (charge end)		55	100	uA
		Shutdown mode R _{PROG} not connected, V _{CC} <V _{BAT} , or V _{CC} <V _{UV})		55	100	uA
V _{FLOAL}	Regulated output voltage	0°C≤T _A ≤85°C I _{BAT} =40mA	4.306	4.35	4.394	V
I _{BAT}	BAT pin current (The condition of current mode is V _{BAT} =3.9V)	R _{PROG} =2.4K, current mode	525	550	575	mA
		R _{PROG} =1.2K, current mode	1050	1100	1150	mA
		Standby mode: V _{BAT} =4.2V	0	-2.5	-6.0	uA
		Shutdown mode, R _{PROG} not connected		±1	±2	uA
		Sleep mode, V _{CC} =0V		-1	-2	uA
I _{TRIKL}	Trickle charge current	V _{BAT} <V _{TRIKL} , R _{PROG} =1.2K	120	130	140	mA
V _{TRIKL}	Trickle charge threshold voltage	R _{PROG} =1.2K, V _{BAT} rising	2.8	2.9	3.0	V
V _{TRHYS}	Trickle voltage hysteresis voltage	R _{PROG} =1.2K	150	200	250	mV
V _{UV}	V _{CC} under voltage lockout threshold	V _{CC} from low to high	3.5	3.7	3.9	V
V _{UVHYS}	V _{CC} under voltage lockout hysteresis		150	200	300	mV
V _{ASD}	V _{CC} -V _{BAT} lockout threshold voltage	V _{CC} from low to high	100	140	180	mV
		V _{CC} from high to low	50	80	110	mV
I _{TERM}	C/10 termination current threshold	R _{PROG} =2.4K	60	70	80	mA
		R _{PROG} =1.2K	120	130	140	mA
V _{PROG}	PROG pin voltage	R _{PROG} =1.2K , current mode	0.9	1.0	1.1	V
V _{CHRG}	\overline{CHRG} Pin output low voltage	$I_{\overline{CHRG}} = 5mA$		0.3	0.6	V
V _{STDBY}	\overline{STDBY} Pin output low voltage	$I_{\overline{STDBY}} = 5mA$				

T_{TEMP-H}	The voltage at TEMP increase			80	83	%VCC
T_{TEMP-L}	The voltage at TEMP decrease		42	45		%VCC
$\Delta V_{RECHARGE}$	Recharge battery threshold voltage	$V_{FLOAT} - V_{RECHRG}$	120	180	240	mV
T_{LIM}	Thermal protection temperature			145		°C
$R_{DS(ON)}$	The resistance of power FET "ON" (between VCC and BAT)			650		mΩ
T_{SS}	Soft-start time	$I_{BAT}=0$ to $I_{BAT}=1200V/R_{PROG}$		20		uS
$T_{RECHARGE}$	Recharge comparator filter time	V_{BAT} from high to low	0.8	1.8	4	mS
T_{TEMP}	Termination comparator filter time	I_{BAT} below $I_{CHG}/10$	0.8	1.8	4	mS
I_{PROG}	PROG pin pull-up current			2.0		uA

Note: The ● denotes specifications which apply over the full operating temperature rang, otherwise specifications are at $T_A=25^{\circ}C$, $V_{CC}=5V$, unless otherwise specified.

Description of the Principle

The AF4057 is a complete CC/CV linear charger for single cell lithium-ion batteries. CC/CV to charge batter by internal MOSFET .It can deliver up to 1.1A of charge current .No blocking diode or external current sense resistor is required. AF4057 include two Open-Drain charge status Pins: Charge status indicator \overline{CHRG} and battery failure status output \overline{STDBY} .

The internal thermal regulation circuit reduces the programmed charge current if the die temperature attempts to rise above a preset value of approximately 145 °C . This feature protects the AF4057 from excessive temperature, and allows the user to push the limits of the power handling capability of a given circuit board without risk of damaging the AF4057 or the external components. Another benefit of adopting thermal regulation is that charge current can be set according to typical, not worst-case, ambient temperatures for a given application with the assurance that the charger will automatically reduce the current in worst-case conditions.

The charge cycle begins when the voltage at the V_{CC} pin rises above the UVLO level, a current set resistor is connected from the PROG pin to ground, and the CE pin is pulled above the chip enable threshold. The \overline{CHRG} pin outputs a logic low to indicate that the charge cycle is on going. At the beginning of the charge cycle, if the battery voltage is below 2.9V, the charge is in precharge mode to bring the cell voltage up to a safe level for charging. The charger goes into the fast charge CC mode once the voltage on the BAT pin rises above 2.9 V. In CC mode, the charge current is set by R_{PROG}. When the battery approaches the regulation voltage 4.35V, the charge current begins to decrease as the AF4057 enters the CV mode. When the current drops to charge termination threshold, the charge cycle is terminated, and \overline{CHRG} pin assumes a high impedance state to indicate that the charge cycle is terminated and \overline{STDBY} pin is pulled low. The charge termination threshold is 10% of the current in CC mode. To restart the charge cycle, remove the input voltage and reapply it, or momentarily force CE pin to 0V. The charge cycle can also be automatically restarted if the BAT pin voltage falls below the recharge threshold. The on-chip reference voltage, error amplifier and the resistor divider provide regulation voltage with 1% accuracy which can meet the requirement of lithium-ion and lithium polymer batteries. When the input voltage is not present, or input voltage is below V_{BAT}, the charger goes into a sleep mode, dropping battery drain current to less than 3μA. This greatly reduces the current drain on the battery and increases the standby time. The charger can be shutdown by forcing the CE pin to GND.

The charging profile is shown in the following figure:

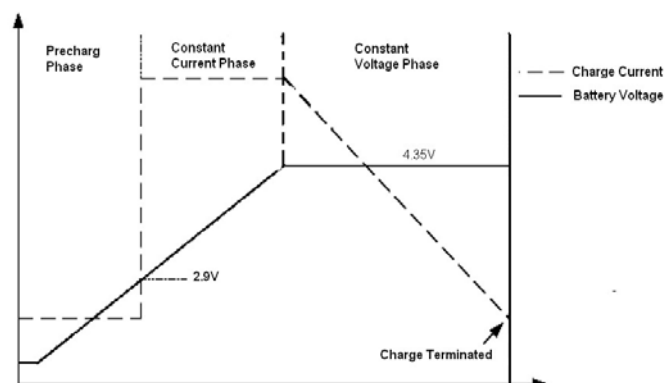

Programming Charge Current

The charge current is programmed using a single resistor from the PROG pin to ground. The program resistor and the charge current are calculated using the following equations.

$$R_{PROG} = \frac{1200}{I_{BAT}};$$

In application, according to the charge current to determine R_{PROG} , the relation between R_{PROG} and charge current can reference the following chart:

R_{PROG} (K)	I_{BAT} (mA)
24K	50
12K	100
4K	300
3K	400
2K	600
1.5K	800
1.2K	1000

Charge Termination

A charge cycle is terminated when the charge current falls to 1/10th the programmed value after the final float voltage is reached. This condition is detected by using an internal filtered comparator to monitor the PROG pin. When the PROG pin voltage falls below 100mV for longer than t_{TEMP} (typically 1.8mS), Charging is terminated. The charge current is latched off and the AF4057 enters standby mode, where the input supply current drops to 55 μ A (**Note:C/10 termination is disabled in trickle charging and thermal limiting modes**).

When charging, transient loads on the BAT pin can cause the PROG pin to fall below 100mV for short periods of time before the DC charge current has dropped to 1/10th the programmed value. The 1.8mS filter time (t_{TEMP}) on the termination comparator ensures that transient loads of this nature do not result in premature charge cycle termination. Once the average charge current drops below 1/10th the programmed value, the AF4057 terminated the charge cycle and ceases to provide any current through the BAT pin. In this state all loads on the BAT pin must be supplied by the battery.

The AF4057 constantly monitors the BAT pin voltage in standby mode. If this voltage drops below the 4.10V recharge threshold (V_{RECHRG}), another charge cycle begins and current is once again supplied to the battery. To manually restart a charge cycle when in standby mode, the input voltage must be removed and reapplied or the charger must be shut down and restarted using the PROG pin. Figure 1 shows the state diagram of a typical charge cycle

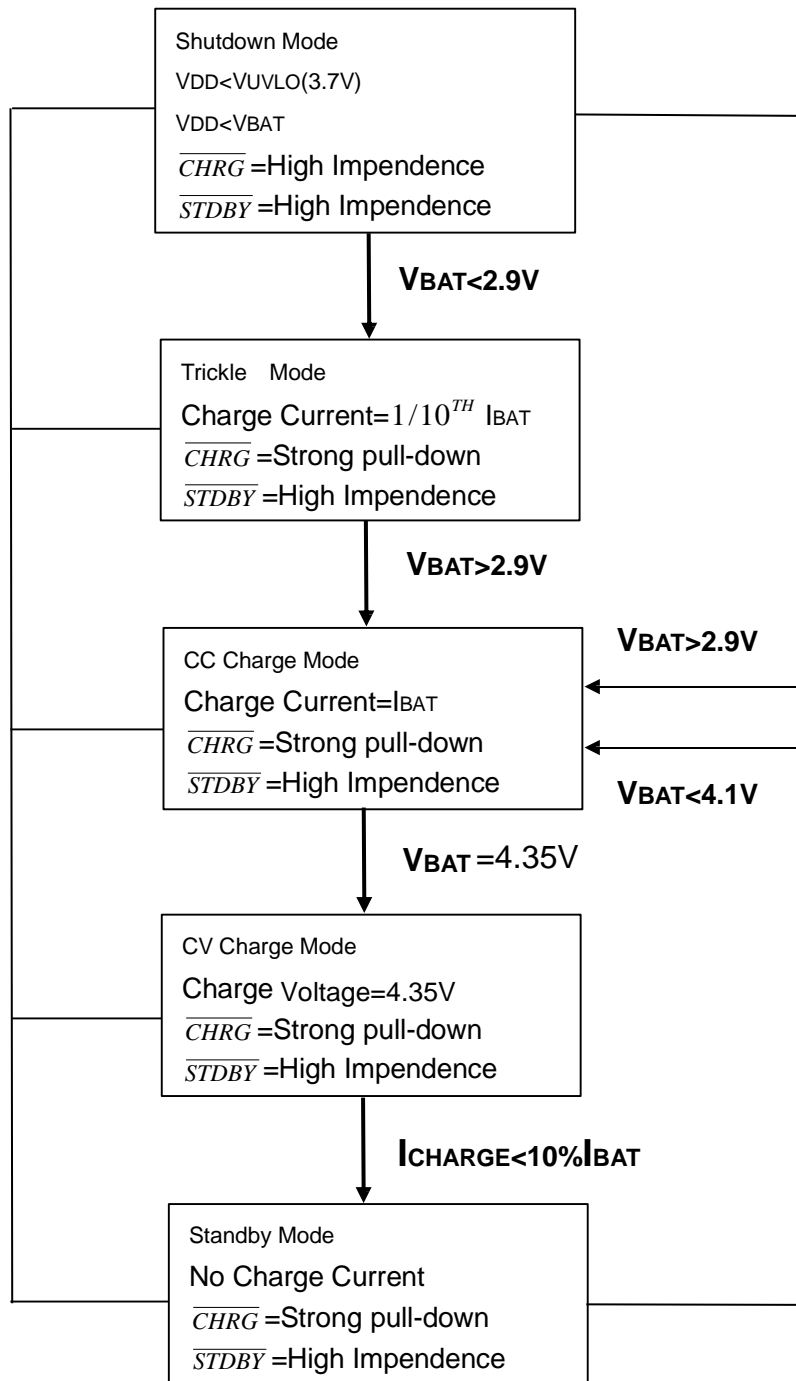

Fig.1 State diagram of a typical charge cycle

Charge status indicator

AF4057 has two open-drain status indicator output \overline{CHRG} and \overline{STDBY} . \overline{CHRG} is pull-down when the AF4057 in a charge cycle. In other status \overline{CHRG} in high impedance, \overline{CHRG} and \overline{STDBY} are all in high impedance when the battery out of the normal temperature.

Represent in failure state, when TEMP pin in typical connecting, or the charger with no battery: red LED and green LED all don't light. The battery temperature sense function is disabled by connecting TEMP pin to GND. If battery is not connected to charger, \overline{CHRG} pin outputs a PWM level to indicate no battery. If BAT pin connects a 10 μ F capacitor, the frequency of \overline{CHRG} flicker about 1-4S, If not use status indicator should set status indicator output connected to GND.

Charger's Status	Red led \overline{CHRG}	Green led \overline{STDBY}
Charging	light	dark
Battery in full state	dark	light
Under-voltage, battery's temperature is too high or too low, or not connect to battery(use TEMP)	dark	dark
BAT pin is connected to 10uF capacitor, No battery mode (TEMP=GND)	Green LED bright, Red LED flicker F=1-4 S	

Thermal limiting

An internal thermal feedback loop reduces the programmed charge current if the die temperature attempts to rise above a preset value of approximately 145 $^{\circ}$ C. The feature protects the AF4057 from excessive temperature and allows the user to push the limits of the power handling capability of a given circuit board without risk of damaging the AF4057. The charge current can be set according to typical (not worst-case) ambient temperature with the assurance that the charger will automatically reduce the current in worst-case conditions.

To prevent the damage caused by the very high or very low temperature done to the battery pack, the AF4057 continuously senses battery pack temperature by measuring the voltage at TEMP pin determined by the voltage divider circuit and the battery's internal NTC thermistor as shown in Figure 1.

The AF4057 compares the voltage at TEMP pin (V_{TEMP}) against its internal V_{LOW} and V_{HIGH} thresholds to determine if charging is allowed. In AF4057, V_{LOW} is fixed at (45% \times Vcc), while V_{HIGH} is fixed at (80% \times Vcc). If $V_{TEMP} < V_{LOW}$ or $V_{TEMP} > V_{HIGH}$, it indicates that the battery temperature is too high or too low and the charge cycle is suspended. When V_{TEMP} is between V_{LOW} and V_{HIGH} , charge cycle resumes. The battery temperature sense function can be disabled by connecting TEMP pin to GND.

Selecting R1 and R2

The values of R1 and R2 in the application circuit can be determined according to the assumed temperature monitor range and thermistor's values. The Follows is an example: Assume temperature monitor range is $T_L \sim T_H$, ($T_L < T_H$); the thermistor in battery has negative temperature coefficient (NTC), R_{TL} is thermistor's resistance at T_L , R_{TH} is the resistance at T_H , so $R_{TL} > R_{TH}$, then at temperature T_L , the voltage at TEMP pin is:

$$V_{TEMPH} = \frac{R_2 // R_{TH}}{R_1 + R_2 // R_{TH}} \times V_{IN}$$

At temperature TH, the voltage at TEMP pin is:

$$V_{TEMPL} = \frac{R_2 // R_{TL}}{R_1 + R_2 // R_{TL}} \times V_{IN}$$

We know $V_{TEMPL} = V_{HIGH} = K_2 \times V_{CC}$ ($K_2=0.8$); $V_{TEMPH} = V_{LOW} = K_1 \times V_{CC}$ ($K_1=0.45$) Then we can have:

$$R_1 = \frac{R_{TL} \times R_{TH} (K_2 - K_1)}{(R_{TL} - R_{TH}) K_2 \times K_1}; \quad R_1 = \frac{R_{TL} \times R_{TH} (K_2 - K_1)}{R_{TL} (K_1 - K_1 \times K_2) - R_{TH} (K_2 - K_1 \times K_2)}$$

Likewise, for positive temperature coefficient thermistor in battery, we have $R_{TH} > R_{TL}$ and we can calculate:

$$R_1 = \frac{R_{TL} \times R_{TH} (K_2 - K_1)}{(R_{TH} - R_{TL}) K_2 \times K_1}; \quad R_1 = \frac{R_{TL} \times R_{TH} (K_2 - K_1)}{R_{TH} (K_1 - K_1 \times K_2) - R_{TL} (K_2 - K_1 \times K_2)}$$

We can conclude that temperature monitor range is independent of power supply voltage V_{CC} and it only depends on R_1 , R_2 , R_{TL} and R_{TH} : The values of R_{TH} and R_{TL} can be found in related battery handbook or deduced from testing data. In actual application, if only one terminal temperature is concerned (normally protecting overheating), there is no need to use R_2 but R_1 . It becomes very simple to calculate R_1 in this case.

Under Voltage lockout (UVLO)

An internal under voltage lockout circuit monitors the input voltage and keeps the charger in shutdown mode until V_{CC} rises above the under voltage lockout threshold. If the UVLO comparator is tripped, the charger will not come out of shutdown mode until V_{CC} rises 140mV above the battery voltage.

Manual terminate

At any time of the cycle of charging will put the AF4057 into disable mode to pull CE pin to GND, or remove R_{PROG} (PROG pin is float). This made the battery drain current to less than $2\mu A$ and reducing the supply current to $55\mu A$. To restart the charge cycle, set CE pin in high level or connect a programming resistor.

If AF4057 in the under voltage Lockout mode, the \overline{CHRG} and \overline{STDBY} are all in high impedance state, or V_{CC} is above BAT pin 140mV, or V_{CC} is too low.

Auto restart

Once charge is been terminated, AF4057 immediately use a 1.8ms filter time ($t_{RECHARGE}$) on the termination comparator to constant monitor the voltage on BAT pin. If this voltage drops below the 4.1V recharge threshold (about between 80% and 90% of V_{CC}), another charge cycle begins. This ensured the battery maintained (or approach) to a charge full status and avoid the requirement of restarting the periodic charging cycle. In the recharge cycle, \overline{CHRG} pin enters a pulled down status.

Stability Considerations

In CC mode, the PROG pin is in the feedback loop, not the battery. The CC mode stability is affected by the impedance at the PROG pin. With no additional capacitance on the PROG pin, the charger is stable with program resistor values as high as 20K. However, additional capacitance on this node reduces the maximum allowed program resistor. Therefore, if I_{PROG} pin is loaded with a capacitance C, the following equation should be used to calculate the maximum resistance value for R_{PROG}:

$$R^{PROG} \leq \frac{1}{2\pi \times 10^5 \times C_{PROG}}$$

As user, may think charge current is important, not instantaneous current. For example, to run a low current mode switch power which parallel connected with battery, the average current from BAT pin usually importance to instantaneous current. In this case, In order to measure average charge current or isolate capacitive load from I_{PROG} pin, a simple RC filter can be used on PROG pin as shown in Figure 2. In order to ensure the stability add a 10K resistor between PROG pin and filter capacitor.

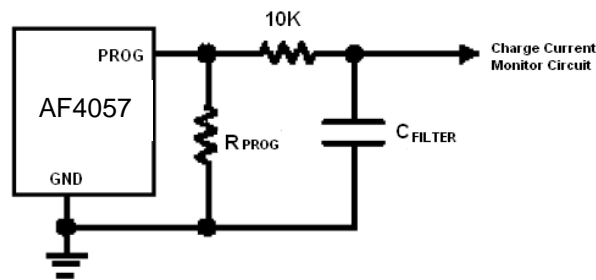

Fig.2 Isolating with capacitive load on PROG Pin

Power Dissipation

The conditions that cause the AF4057 to reduce charge current through thermal feedback can be approximated by considering the power dissipated in the IC. Nearly all of this power dissipation is generated by the internal MOSFET-this is calculated to be approximately:

$P_D = (V_{CC} - V_{BAT}) \times I_{BAT}$ The approximate ambient temperature at which the thermal feedback begins to protect the IC is:

$$T_A = 145^\circ C - P_D \times \theta_{JA}; \quad \text{So: } T_A = 145^\circ C - (V_{CC} - V_{BAT}) \times I_{BAT} \times \theta_{JA}$$

For example: The AF4057 with 5V supply voltage through programmable provides full limiting current 850mA to a charge lithium-ion battery with 3.85V voltage. If θ_{JA} is 100 °C/W (reference to PCB layout considerations), When AF4057 begins to decrease the charge current, the ambient temperature about:

$$T_A = 145 - (5 - 3.85) \times 0.85 \times 100 = 47.25^\circ C$$

AF4057 can work in the condition of the temperature is above 47.25 °C, but the charge current will pull down to below 850mA. In a fixed ambient temperature, the charge current is calculated to be approximately :

$$I_{BAT} = \frac{145^{\circ}C - T_A}{(V_{CC} - V_{BAT}) \times \theta_{JA}}$$

Just as Description of the Principle part talks about so, the current on PROG pin will reduce in proportion to the reduced charge current through thermal feedback. In AF4057 design applications don't need to considerate the worst case of thermal condition, this point is importance, because if the junction temperature up to 145°C, AF4057 will auto reduce the power dissipation.

Thermal Considerations

Because of the small size of the thin ESOP-8 package, it is important to use a good thermal PC board layout to maximize the available charge current. The PC board copper is the heat sink. The footprint copper pads should be as wide as possible and expand out to larger copper areas to spread and dissipate the heat to the surrounding ambient. Other heat sources on the board, not related to the charger, must also be considered when designing a PC board layout because they will affect overall temperature rise and the maximum charge current.

Add thermal regulation current

It will effective to decrease the power dissipation through reduce the voltage of both ends of the inner MOSFET. In the thermal regulation, this action of transporting current to battery will raise. One of the measure is through an external component(as a resistor or diode) to consume some power dissipation.

For example: The AF4057 with 5V supply voltage through programmable provides full limiting current 1000mA to a charge lithium-ion battery with 3.8V voltage. If θ_{JA} is 120 °C/W, so that at 25 °C ambient temperature, the charge current is calculated to be approximately:

$$I_{BAT} = \frac{145^{\circ}C - 25^{\circ}C}{(V_{CC} - I_{BAT} \times R_{CC} - V_{BAT}) \times \theta_{JA}}$$

In order to increase the thermal regulation charge current, can decrease the power dissipation of the IC through reducing the voltage (as show fig.3) of both two ends of the resistor which connecting in series with a 5V AC adapter. With square equation to calculate I_{BAT} :

$$I_{BAT} = \frac{V_{CC} - V_{BAT} - \sqrt{(V_{CC} - V_{BAT})^2 - \frac{4R_{CC} \times (145^{\circ}C - T_A)}{\theta_{JA}}}}{2R_{CC}}$$

If $R_{CC}=0.25\Omega$, $V_{CC}=5V$, $V_{BAT}=3.75V$, $T_A=25^{\circ}C$ and $\theta_{JA}=120^{\circ}C/W$, we can calculate the thermal regulation charge current: $I_{BAT} = 1080mA$. It means that in this structure it can output 1000mA full limiting charge current at more high ambient temperature environment.

Although it can transport more energy and reduce the charge time in this application, but actually spread charge time, if AF4057 stay in under-voltage state, when V_{CC} becomes too low in voltage mode. Fig.4 shows how the voltage reduced with increase R_{CC} value in this circuit. This technique will act the best function when in order to maintain the minimize the dimension of the components and avoid voltage decreased to minimize R_{CC} .

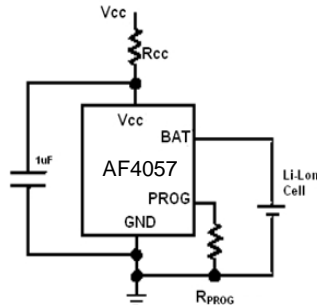

Fig.3 A Circuit To Maximum The Thermal Regulation Charge Current

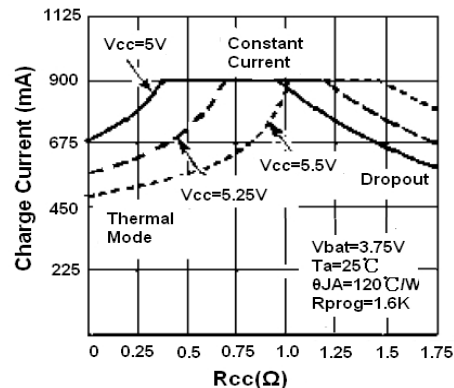

Fig.4 The Relationship Curve Between Charge Current With Rcc

VCC bypass capacitor

Many types of capacitors can be used for input bypassing, however, caution must be exercised when using multilayer ceramic capacitors. Because of the self-resonant and high Q characteristics of some types of ceramic capacitors, high voltage transients can be generated under some start-up conditions, such as connecting the charger input to a live power source. Adding a 1.5 Ω resistor in series with a ceramic capacitor will minimize start-up voltage transients.

Charging Current Soft Start

AF4057 includes a soft start circuit which used to maximize to reduce the surge current in the beginning of charge cycle. When restart a new charge cycle, the charging current ramps up from 0 to the full charging current within 20 μs. In the start process it can maximize to reduce the action which caused by surge current load.

USB and Wall Adapter Power

AF4057 allows charging from a USB port, a wall adapter can also be used to charge Li-Ion/Li-polymer batteries. Figure 5 shows an example of how to combine wall adapter and USB power inputs. A P-channel MOSFET, Q1, is used to prevent back conducting into the USB port when a wall adapter is present and Schottky diode, D1, is used to prevent USB power loss through the 1KΩ pull-down resistor.

Generally, AC adaptor is able to provide bigger much current than the value of specific current limiting which is 500mA for USB port. So can rise charge current to 600mA with using a N-MOSFET (Q1) and an additional set resistor value as high as 10K.

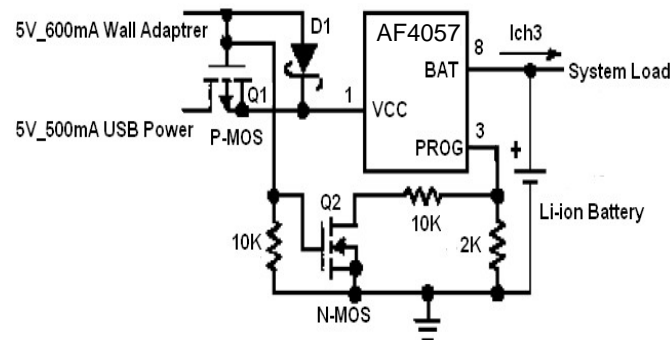

Fig.5:Combining Wall Adapter and USB Power

Board Layout Considerations

R_{PROG} at PROG pin should be as close to AF4057 as possible, also the parasitic capacitance at PROG pin should be kept as small as possible.

The capacitance at VCC pin and BAT pin should be as close to AF4057 as possible.

During charging, AF4057's temperature may be high, the NTC thermistor should be placed far enough to AF4057 so that the thermistor can reflect the battery's temperature correctly.

It is very important to use a good thermal PC board layout to maximize charging current. The thermal path for the heat generated by the IC is from the die to the copper lead frame through the package lead (especially the ground lead) to the PC board copper, the PC board copper is the heat sink. The footprint copper pads should be as wide as possible and expand out to larger copper areas to spread and dissipate the heat to the surrounding ambient. Feed through vias to inner or backside copper layers are also useful in improving the overall thermal performance of the charger. Other heat sources on the board, not related to the charger, must also be considered when designing a PC board layout because they will affect overall temperature rise and the maximum charge current.

The ability to deliver maximum charge current under all conditions require that the exposed metal pad on the back side of the AF4057 package be soldered to the PC board ground. Failure to make the thermal contact between the exposed pad on the backside of the package and the copper board will result in larger thermal resistance.

ESOP-8

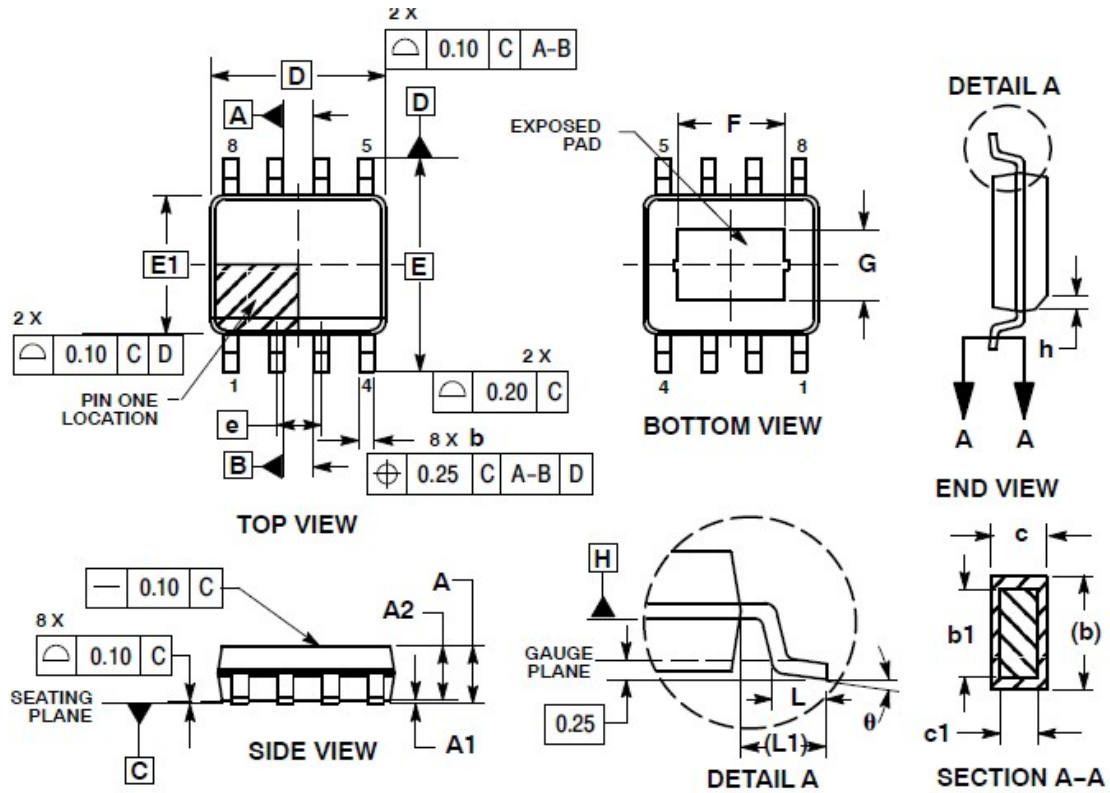

SOLDERING FOOTPRINT

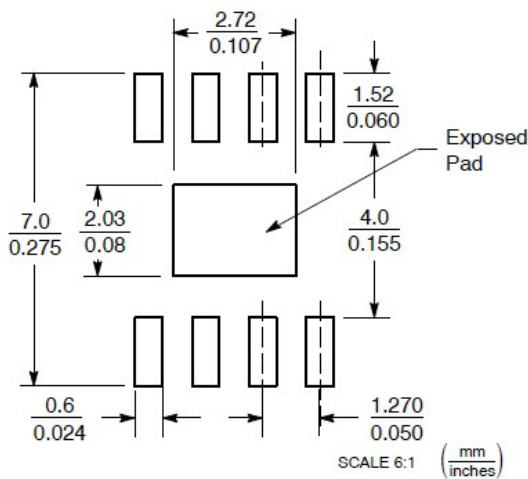

DIM	MILLIMETERS	
	MIN	MAX
A	1.35	1.75
A1	0.00	0.10
A2	1.35	1.65
b	0.31	0.51
b1	0.28	0.48
c	0.17	0.25
c1	0.17	0.23
D	4.90 BSC	
E	6.00 BSC	
E1	3.90 BSC	
e	1.27 BSC	
L	0.40	1.27
L1	1.04 REF	
F	2.24	3.20
G	1.55	2.51
h	0.25	0.50
θ	0°	8°