

## General Description

The AF6291 is a current mode boost DC-DC converter. Its PWM circuitry with built-in 0.2Ω power MOSFET make this regulator highly power efficient. The internal compensation network also minimizes as much as 6 external component counts. The non-inverting input of error amplifier connects to a 0.6V precision reference voltage and internal soft-start function can reduce the inrush current.

The AF6291 is available in the SOT23 -6L package and provides space-saving PCB for the application fields.

## Features

- Adjustable Output up to 12V
- Internal Fixed PWM frequency: 1.5MHz
- Precision Feedback Reference Voltage: 0.6V (±2%)
- Internal 0.2 Ω , 2A, 16V Power MOSFET
- Shutdown Current: 0.1μA
- Over Temperature Protection
- Adjustable Over Current Protection: 0.5A ~ 2.5A
- Package: SOT23-6L

## Applications

- Chargers
- LCD Displays
- Digital Cameras
- Handheld Devices
- Portable Products

## Typical Application Circuit

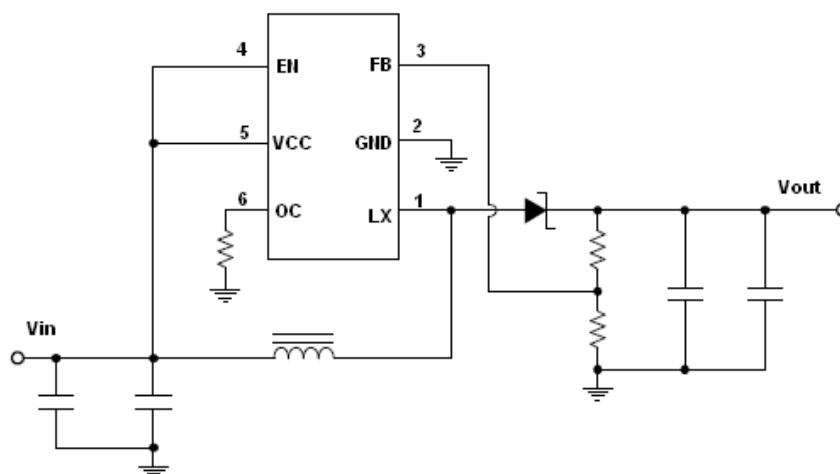

Function Block Diagram

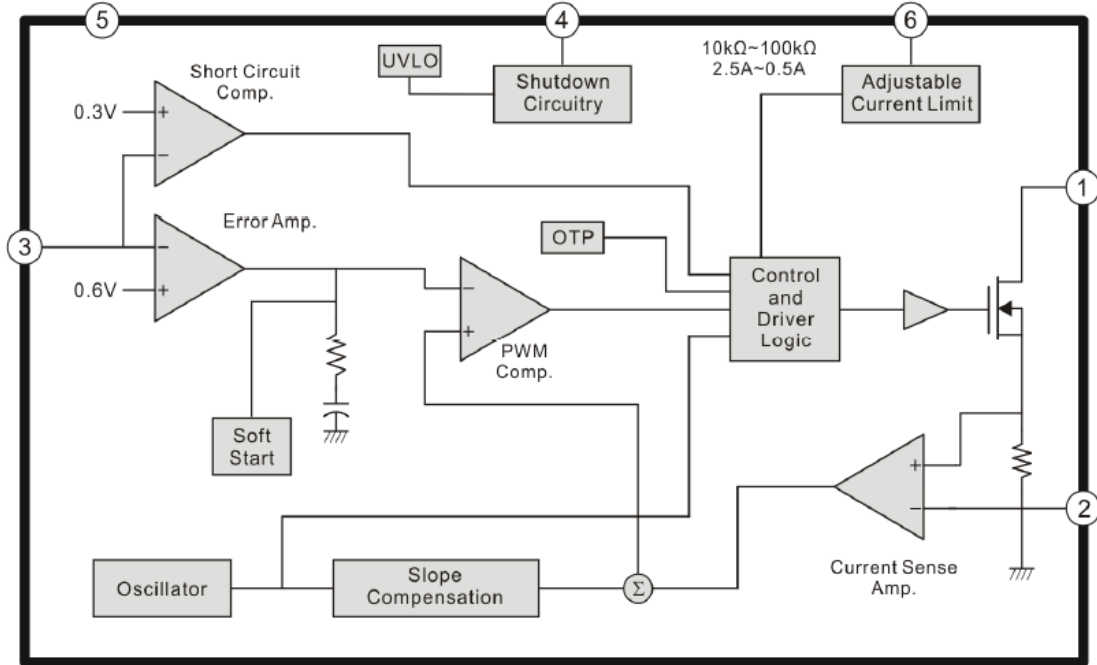

Pin Descriptions

SOT23-6L

Top View

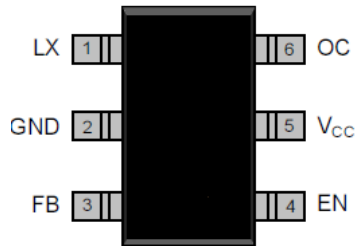

| Name            | No. | I / O | Description                                   |
|-----------------|-----|-------|---|
| LX              | 1   | O     | Power Switch Output                           |
| GND             | 2   | P     | IC Ground                                     |
| FB              | 3   | I     | Error Amplifier Inverting Input               |
| EN              | 4   | I     | Enable Control (Active High)                  |
| V <sub>CC</sub> | 5   | P     | IC Power Supply                               |
| OC              | 6   | I     | Adjustable Current Limit (Floating Available) |



## Absolute Maximum Ratings

| Parameter                  | Symbol        | Conditions                   | Min. | Typ. | Max. | Unit            |
|----------------------------|---------------|------------------------------|------|------|------|-----------------|
| Supply Voltage             | $V_{CC}$      |                              | 0    |      | 6    | V               |
| LX Voltage                 | $V_{LX}$      |                              | 0    |      | 16   | V               |
| EN,FB Voltage              |               |                              | 0    |      | 6    | V               |
| Power Dissipation          | $P_D$         | SOT23-6L @ $T_A=25^{\circ}C$ |      |      | 455  | mW              |
| Thermal Resistance (Note1) | $\theta_{JA}$ | SOT23-6L                     |      |      | +220 | $^{\circ}C / W$ |
| Junction Temperature       | $T_J$         |                              |      |      | +150 | $^{\circ}C$     |
| Operating Temperature      | $T_{OP}$      |                              | -40  |      | +85  | $^{\circ}C$     |
| Storage Temperature        | $T_{ST}$      |                              | -65  |      | +150 | $^{\circ}C$     |
| Lead Temperature           |               | (soldering, 10 sec)          |      |      | +260 | $^{\circ}C$     |

**Note1:**

$\theta_{JA}$  is measured in the natural convection at  $T_A=25^{\circ}C$  on a low effective thermal conductivity test board of JEDEC 51-3 thermal measurement standard.

## Recommended Operating Conditions

| Parameter                   | Symbol   | Conditions          | Min. | Typ. | Max. | Unit        |
|-----------------------------|----------|---------------------|------|------|------|-------------|
| Supply Voltage              | $V_{IN}$ |                     | 2.6  |      | 5.5  | V           |
| Operating Temperature Range | $T_A$    | Ambient Temperature | -40  |      | +85  | $^{\circ}C$ |

**DC Electrical Characteristics** ( $V_{CC}=3.3V$ ,  $T_A=25^{\circ}C$ , unless otherwise specified)

| Parameter                     | Symbol              | Conditions                          | Min   | Typ  | Max   | Unit        |
|-------------------------------|---------------------|-------------------------------------|-------|------|-------|-------------|
| System Supply Input           |                     |                                     |       |      |       |             |
| Input Supply Range            | $V_{CC}$            |                                     | 2.6   |      | 5.5   | V           |
| Under Voltage Lockout         | $V_{UVLO}$          |                                     |       | 2.2  |       | V           |
| UVLO Hysteresis               |                     |                                     |       | 0.1  |       | V           |
| Quiescent Current             | $I_{DC}$            | $V_{FB}=0.6V$ No Switching          |       | 0.19 |       | mA          |
| Average Supply Current        | $I_{DC}$            | $V_{FB}=0.55V$ Switching            |       | 2.84 |       | mA          |
| Shutdown Supply Current       | $I_{DC}$            | $V_{EN}=GND$                        |       | 0.1  |       | $\mu A$     |
| Oscillator                    |                     |                                     |       |      |       |             |
| Operation Frequency           | $F_{OSC}$           | $V_{FB}=1.0V$                       | 1.2   | 1.5  | 1.8   | MHz         |
| Frequency Change With Voltage | $\Delta f/\Delta V$ | $V_{CC}=2.6V$ to $5.5V$             |       | 5    |       | %           |
| Maximum Duty Cycle            | $T_{DUTY}$          |                                     |       | 90   |       | %           |
| Reference Voltage             |                     |                                     |       |      |       |             |
| Reference Voltage             | $V_{REF}$           |                                     | 0.588 | 0.6  | 0.612 | V           |
| Line Regulation               |                     | $V_{CC}=2.6V\sim 5.5V$              |       | 0.05 |       | %/V         |
| Enable Control                |                     |                                     |       |      |       |             |
| Enable Voltage                | $V_{EN}$            |                                     | 0.96  |      |       | V           |
| Shutdown Voltage              | $V_{EN}$            |                                     |       |      | 0.6   | V           |
| MOSFET                        |                     |                                     |       |      |       |             |
| On Resistance Of Driver       | $R_{D(ON)}$         | $I_{LX}=2A$                         |       | 0.2  |       | $\Omega$    |
| Protection                    |                     |                                     |       |      |       |             |
| OCP Current                   | $I_{OCP}$           |                                     | 2     |      | 2.6   | A           |
| Adjustable OCP Current        | $I_{OCP}$           | With External Resistor:<br>10K~100K | 0.5   |      | 2.5   | A           |
| OTP Temperature               | $T_{OTP}$           |                                     |       | +150 |       | $^{\circ}C$ |



## Function Description

### Operation

The AF6291 is a current mode boost converter. The constant switching frequency is 1MHz and operates with pulse width modulation (PWM). Build-in 16V / 2A MOSFET provides a high output voltage. The control loop architecture is peak current mode control; therefore slope compensation circuit is added to the current signal to allow stable operation for duty cycles larger than 50%.

### Soft Start Function

Soft start circuitry is integrated into AF6291 to avoid inrush current during power on. After the IC is enabled, the output of error amplifier is clamped by the internal soft-start function, which causes PWM pulse width increasing slowly and thus reducing input surge current.

### Current Limit Program

A resistor between OC and GND pin programs peak switch current. The resistor value should be between 10k and 100k. The current limit will be set from 2.5A to 0.5A. Keep traces at this pin as short as possible. Do not put capacitance at this pin. To set the over current trip point according to the following equation:

$$I_{OCP} = \frac{48000}{R3}$$

### Over Temperature Protection (OTP)

AF6291 will turn off the power MOSFET automatically when the internal junction temperature is over 150°C. The power MOSFET wake up when the junction temperature drops 30°C under the OTP threshold temperature.

### Output Disconnect

When power on and the EN pin will be pulled high. The AF6291 start up and operates. The external PMOS is turned on and current through it for output loading. While output loading is increase, output voltage is drop. When the FB pin voltage is under 0.3V, the EN pin sinks 20μA current, the external PMOS will be turn off. The output short condition will be disconnected.

## Application Information

### Inductor Selection

Inductance value is decided based on different condition. 3.3uH to 4.7uH inductor value is recommended for general application circuit. There are three important inductor specifications, DC resistance, saturation current and core loss. Low DC resistance has better power efficiency. Also, it avoid inductor saturation which will cause circuit system unstable and lower core loss at 1.5 MHz.

### Capacitor Selection

The output capacitor is required to maintain the DC voltage. Low ESR capacitors are preferred to reduce the output voltage ripple. Ceramic capacitor of X5R and X7R are recommended, which have low equivalent series resistance (ESR) and wider operation temperature range.

### Diode Selection

Schottky diodes with fast recovery times and low forward voltages are recommended. Ensure the diode average and peak current rating exceed the average output current and peak inductor current. In addition, the diode's reverse breakdown voltage must exceed the output voltage.

### Output Voltage Programming

The output voltage is set by a resistive voltage divider from the output voltage to FB. The output voltage is:

$$V_{OUT} = 0.6V \left( 1 + \frac{R1}{R2} \right)$$

### Layout Considerations

1. The power traces, consisting of the GND trace, the LX trace and the VCC trace should be kept short, direct and wide.
2. LX, L and D switching node, wide and short trace to reduce EMI.
3. Place CIN near VCC pin as closely as possible to maintain input voltage steady and filter out the pulsing input current.
4. The resistive divider R1 and R2 must be connected to FB pin directly as closely as possible.
5. FB is a sensitive node. Please keep it away from switching node, LX.
6. The GND of the IC, CIN and COUT should be connected close together directly to a ground plane.

Typical Application

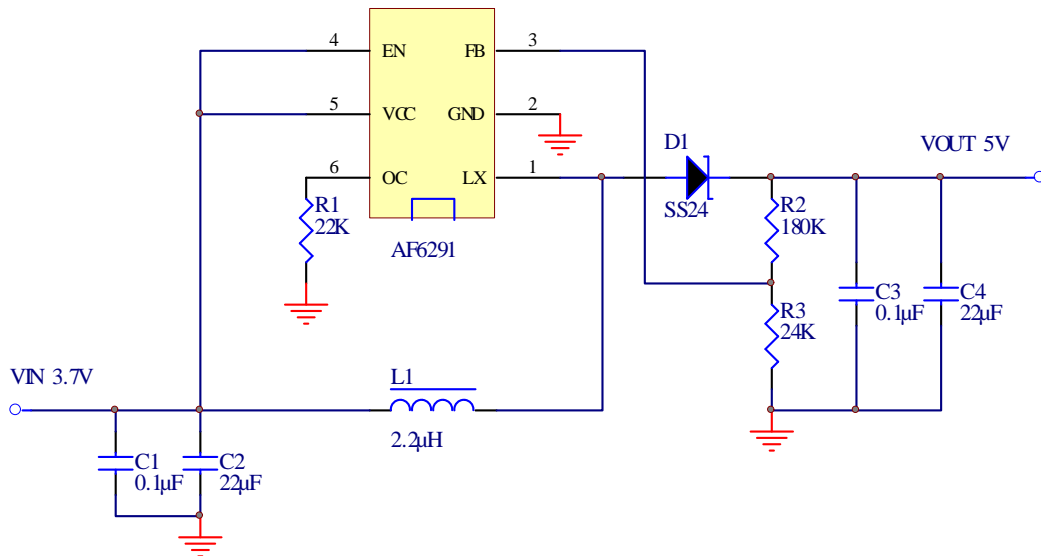

General Boost Converter

Package Outline

SOT23-6L

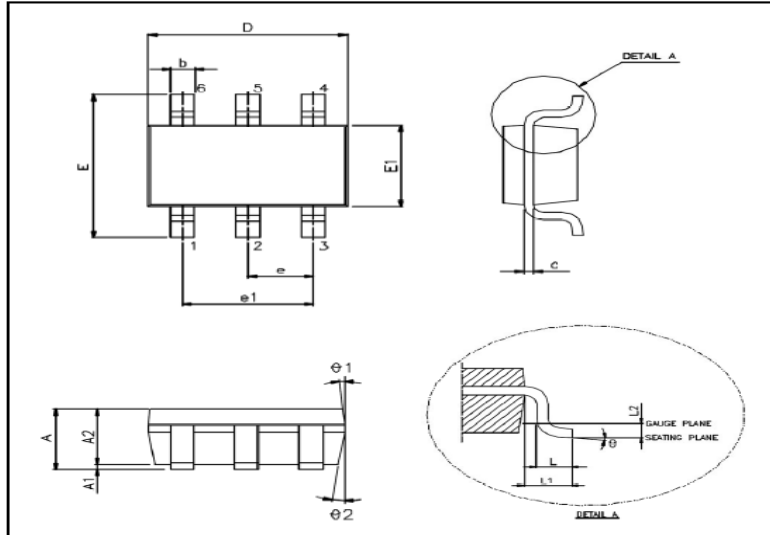

Unit: mm

| Symbols | Min. (mm) | Max. (mm) |
|---------|-----------|-----------|
| A       | 1.050     | 1.450     |
| A1      | 0.050     | 0.150     |
| A2      | 0.900     | 1.300     |
| b       | 0.300     | 0.500     |
| c       | 0.080     | 0.220     |
| D       | 2.900 BSC |           |
| E       | 2.800 BSC |           |
| E1      | 1.600 BSC |           |
| e       | 0.950 BSC |           |
| e1      | 1.900 BSC |           |
| L       | 0.300     | 0.600     |
| L1      | 0.600 REF |           |
| L2      | 0.250 BSC |           |
| θ°      | 0°        | 8°        |
| θ1°     | 3°        | 7°        |
| θ2°     | 6°        | 15°       |

Note:

1. Package dimensions are in compliance with JEDEC outline: MO-178 AB.
2. Dimension "D" does not include molding flash, protrusions or gate burrs.
3. Dimension "E1" does not include inter-lead flash or protrusions.