



AF8510C

N AND P-CHANNEL ENHANCEMENT MODE POWER MOSFET

■ Features

- Lower On-Resistance
- Simple Drive Requirement
- Fast Switching Performance
- Pb Free Plating Product

■ Product Summary

CH	BV _{DSS} (V)	R _{DS(ON)} (mΩ)	I _D (A)
N	30	28	6.9
P	-30	55	-5.3

■ General Description

The advanced power MOSFET provides the designer with the best combination of fast switching, ruggedized device design, low on-resistance and costeffectiveness.

The SO-8 package is universally preferred for all commercial-industrial surface mount applications and suited for low voltage applications such as DC/DC converters.

■ Pin Assignments

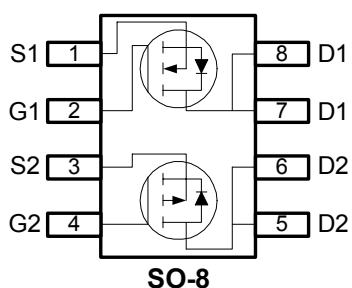

■ Pin Descriptions

Pin Name	Description
S1	Source (NMOS)
G1	Gate (NMOS)
D1	Drain (NMOS)
S2	Source (PMOS)
G2	Gate (PMOS)
D2	Drain (PMOS)

■ Ordering information

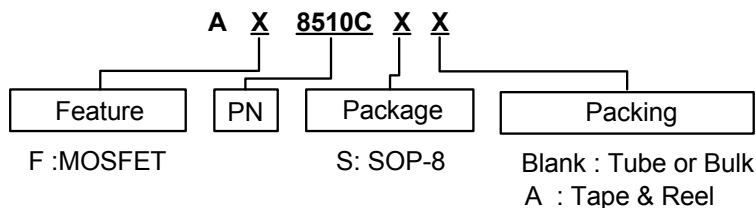



AF8510C

N AND P-CHANNEL ENHANCEMENT MODE POWER MOSFET

■ Absolute Maximum Ratings

Symbol	Parameter	N-Channel	P-Channel	Units	
V_{DS}	Drain-Source Voltage	30	-30	V	
V_{GS}	Gate-Source Voltage	± 20	± 20	V	
I_D	Continuous Drain Current (Note 1)	$T_A=25^\circ\text{C}$	6.9	-5.3	V
		$T_A=70^\circ\text{C}$	5.5	-4.2	V
I_{DM}	Pulsed Drain Current (Note 2)	30	-30	A	
P_D	Total Power Dissipation	$T_A=25^\circ\text{C}$		2.0	W
	Linear Deratmg Factor			0.016	W/°C
T_J, T_{STG}	Operating Junction and Storage Temperature Range			-55 to 150	°C

■ Thermal Data

Symbol	Parameter	Maximum	Units
Rthj-amb	Thermal Resistance Junction-ambient (Note 1) Max.	62.5	°C/W

■ N-CH Electrical Characteristics at $T_J=25^\circ\text{C}$ unless otherwise specified

Symbol	Parameter	Test Conditions	Min.	Typ.	Max.	Units
BV_{DSS}	Drain-Source Breakdown Voltage	$V_{GS}=0V, I_D=250\mu\text{A}$	30	-	-	V
BV_{DSS}/T_J	Breakdown Voltage Temperature Coefficient	Reference to 25°C , $I_D=1\text{mA}$	-	0.02	-	V/°C
$R_{DS(ON)}$	Static Drain-Source On-Resistance (Note 3)	$V_{GS}=10V, I_D=5A$	-	-	28	mΩ
		$V_{GS}=4.5V, I_D=3A$	-	-	40	mΩ
$V_{GS(th)}$	Gate Threshold Voltage	$V_{DS}=V_{GS}, I_D=250\mu\text{A}$	1	-	3	V
g_{fs}	Forward Transconductance	$V_{DS}=10V, I_D=5A$	-	4.6	-	S
I_{DSS}	Drain-Source Leakage Current ($T_J=25^\circ\text{C}$)	$V_{DS}=30V, V_{GS}=0V$	-	-	1	uA
	Drain-Source Leakage Current ($T_J=70^\circ\text{C}$)	$V_{DS}=24V, V_{GS}=0V$	-	-	25	uA
I_{GSS}	Gate-Source Leakage	$V_{GS}=\pm 20V$	-	-	± 100	nA
Q_g	Total Gate Charge (Note 3)	$I_D=6.9A,$	-	10	16	nC
Q_{gs}	Gate-Source Charge	$V_{DS}=24V,$	-	2	-	
Q_{gd}	Gate-Drain ("Miller") Charge	$V_{GS}=4.5V$	-	6	-	
$t_{d(on)}$	Turn-On Delay Time (Note 3)	$V_{DS}=15V,$	-	8	-	ns
t_r	Rise Time	$I_D=1A,$	-	7	-	
$t_{d(off)}$	Turn-Off Delay Time	$R_G=3.3\Omega, V_{GS}=10V$	-	20	-	
t_f	Fall-Time	$R_D=15\Omega$	-	6	-	
C_{iss}	Input Capacitance	$V_{GS}=0V,$	-	540	870	pF
C_{oss}	Output Capacitance	$V_{DS}=25V,$	-	160	-	
C_{rss}	Reverse Transfer Capacitance	$f=1.0\text{MHz}$	-	120	-	

■ Source-Drain Diode

Symbol	Parameter	Test Conditions	Min.	Typ.	Max.	Unit
V_{SD}	Forward On Voltage (Note 3)	$I_S=1.7A, V_{GS}=0V$	-	-	1.2	V
t_{rr}	Reverse Recovery Time	$I_S=6.9A, V_{GS}=0V$	-	20	-	ns
Q_{rr}	Reverse Recovery Charge	$di/dt=100A/\mu\text{s}$	-	11	-	nC



AF8510C

N AND P-CHANNEL ENHANCEMENT MODE POWER MOSFET

■ P-CH Electrical Characteristics at $T_J=25^\circ\text{C}$ unless otherwise specified

Symbol	Parameter	Test Conditions	Min.	Typ.	Max.	Units
BV_{DSS}	Drain-Source Breakdown Voltage	$V_{GS}=0V, I_D=250\mu A$	-30	-	-	V
BV_{DSS}/T_J	Breakdown Voltage Temperature Coefficient	Reference to 25°C , $I_D=1\text{mA}$	-	-0.023	-	$V/^\circ\text{C}$
		$V_{GS}=-10V, I_D=-5A$	-	-	55	m Ω
		$V_{GS}=-4.5V, I_D=-3A$	-	-	90	
$V_{GS(th)}$	Gate Threshold Voltage	$V_{DS}=V_{GS}, I_D=-250\mu A$	1	-	-3	V
g_{fs}	Forward Transconductance	$V_{DS}=-10V, I_D=-5A$	-	4.9	-	S
I_{DSS}	Drain-Source Leakage Current ($T_J=25^\circ\text{C}$)	$V_{DS}=-30V, V_{GS}=0V$	-	-	-1	μA
	Drain-Source Leakage Current ($T_J=70^\circ\text{C}$)	$V_{DS}=-24V, V_{GS}=0V$	-	-	-25	
I_{GSS}	Gate-Source Leakage	$V_{GS}=\pm 20V$	-	-	± 100	nA
Q_g	Total Gate Charge (Note 3)	$I_D=-5.3A,$	-	9	15	nC
Q_{gs}	Gate-Source Charge	$V_{DS}=-24V,$	-	2	-	
Q_{gd}	Gate-Drain ("Miller") Charge	$V_{GS}=-4.5V$	-	6	-	
$t_{d(on)}$	Turn-On Delay Time (Note 3)	$V_{DS}=-15V,$	-	10	-	ns
t_r	Rise Time	$I_D=1A,$	-	8	-	
$t_{d(off)}$	Turn-Off Delay Time	$R_G=3.3\Omega, V_{GS}=-10V$	-	25	-	
t_f	Fall-Time	$R_D=15\Omega$	-	13	-	
C_{iss}	Input Capacitance	$V_{GS}=0V,$	-	580	930	pF
C_{oss}	Output Capacitance	$V_{DS}=25V,$	-	180	-	
C_{rss}	Reverse Transfer Capacitance	$f=1.0\text{MHz}$	-	120	-	

■ Source-Drain Diode

Symbol	Parameter	Test Conditions	Min.	Typ.	Max.	Unit
V_{SD}	Forward On Voltage (Note 3)	$I_S=1.7A, V_{GS}=0V$	-	-	-1.2	V
t_{rr}	Reverse Recovery Time	$I_S=-5.3A, V_{GS}=0V,$	-	21	-	ns
Q_{rr}	Reverse Recovery Charge	$di/dt=100A/\mu s$	-	17	-	nC

Note 1: Surface mounted on 1 in² copper pad of FR4 board; 135°C/W when mounted on Min. copper pad.

Note 2: Pulse width limited by Max. junction temperature.

Note 3: Pulse width $\leq 300\mu s$, duty cycle $\leq 2\%$.



AF8510C

N AND P-CHANNEL ENHANCEMENT MODE POWER MOSFET

■ Typical Performance Characteristics (N-Channel)

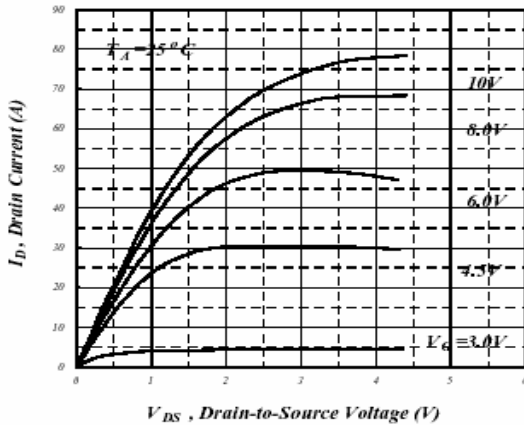

Fig 1. Typical Output Characteristics

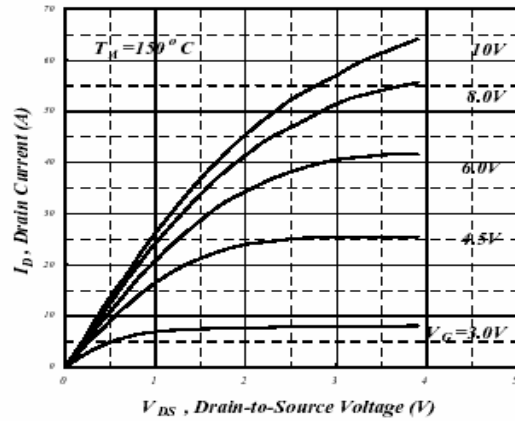

Fig 2. Typical Output Characteristics

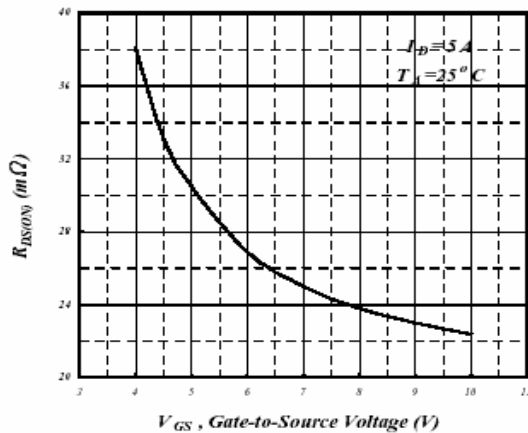

Fig 3. On-Resistance v.s. Gate Voltage

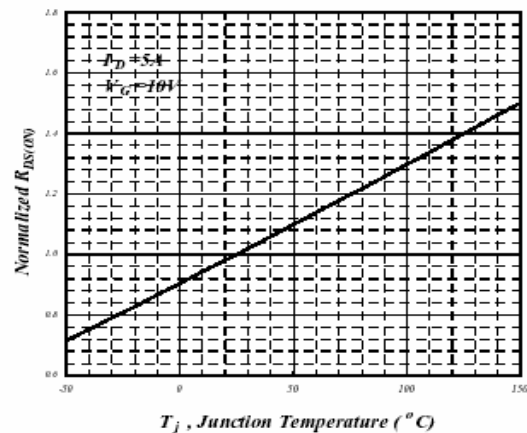

Fig 4. Normalized On-Resistance v.s. Junction Temperature

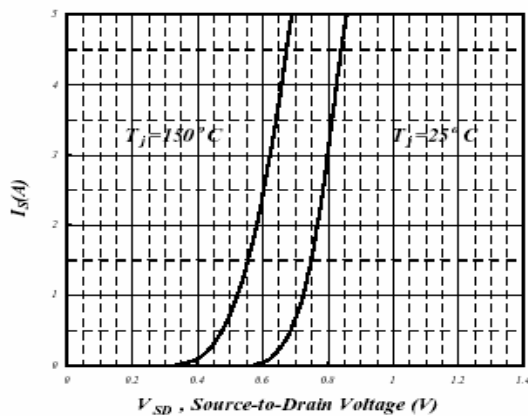

Fig 5. Forward Characteristic of Reverse Diode

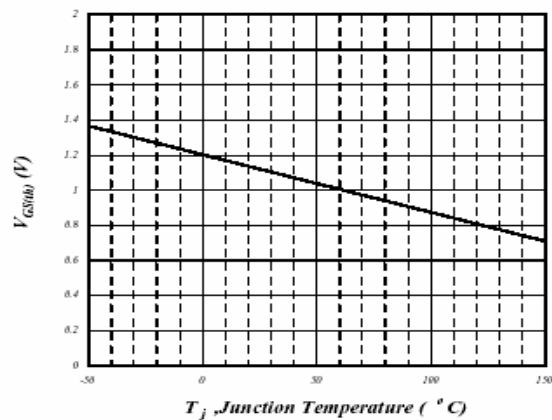

Fig 6. Gate Threshold Voltage v.s. Junction Temperature



AF8510C

N AND P-CHANNEL ENHANCEMENT MODE POWER MOSFET

■ Typical Performance Characteristics (N-Channel) (Continued)

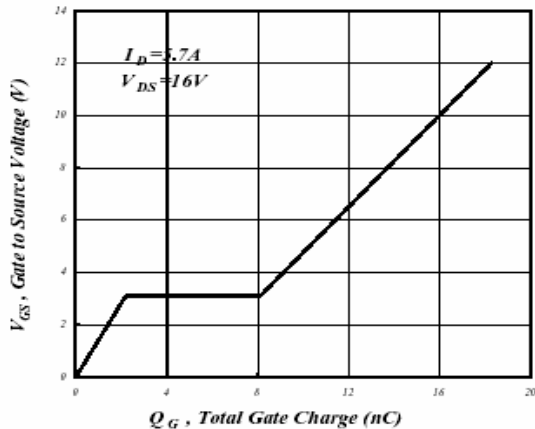

Fig 7. Gate Charge Characteristics

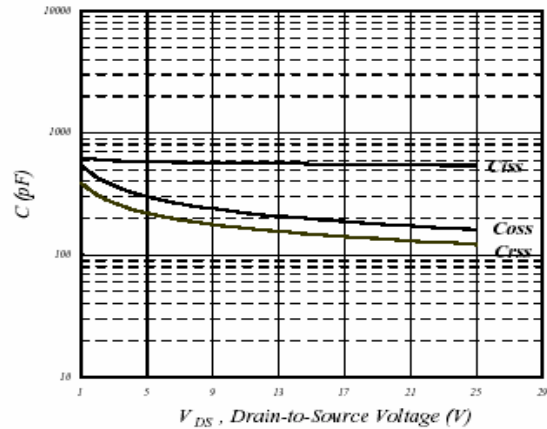

Fig 8. Typical Capacitance Characteristics

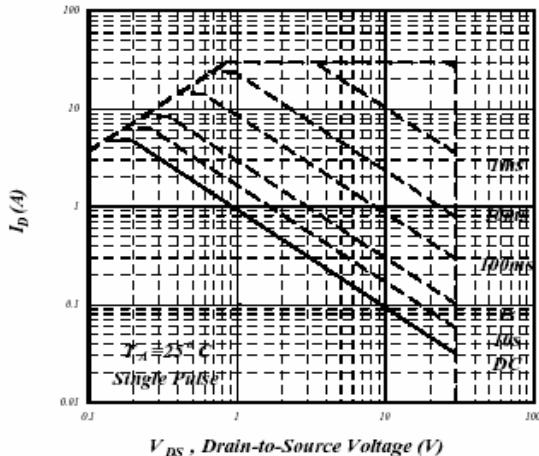

Fig 9. Maximum Safe Operation Area

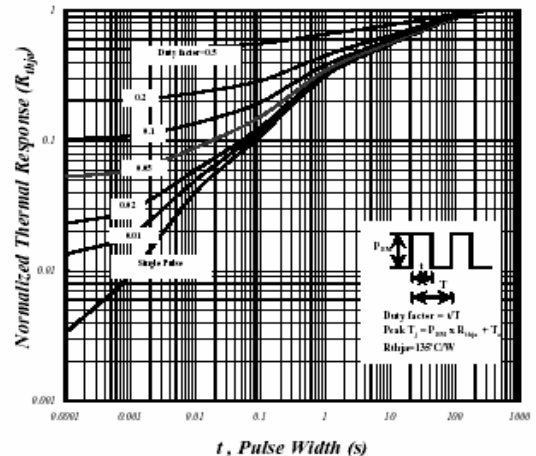

Fig 10. Effective Transient Thermal Impedance

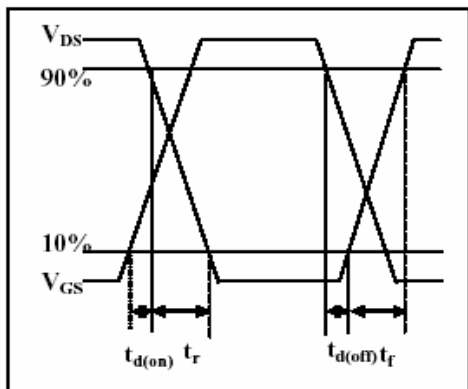

Fig 11. Switching Time Waveform

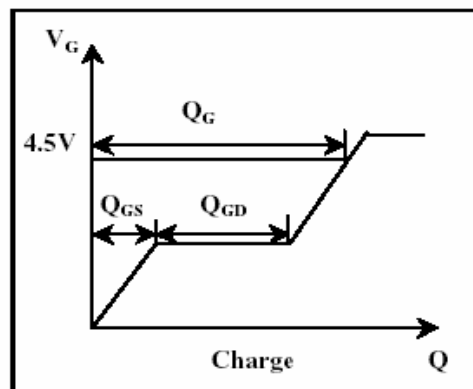

Fig 12. Gate Charge Waveform



AF8510C

N AND P-CHANNEL ENHANCEMENT MODE POWER MOSFET

Typical Performance Characteristics (P-Channel) (Continued)

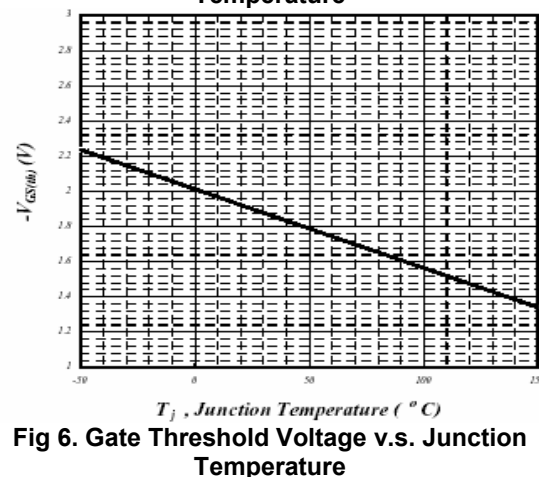
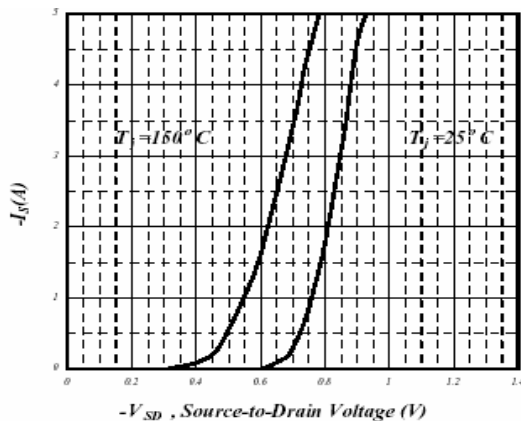
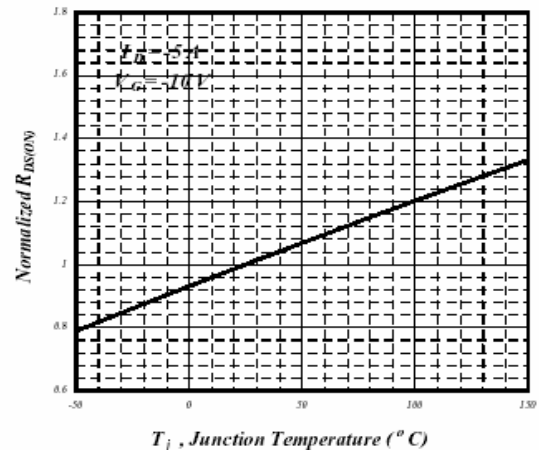
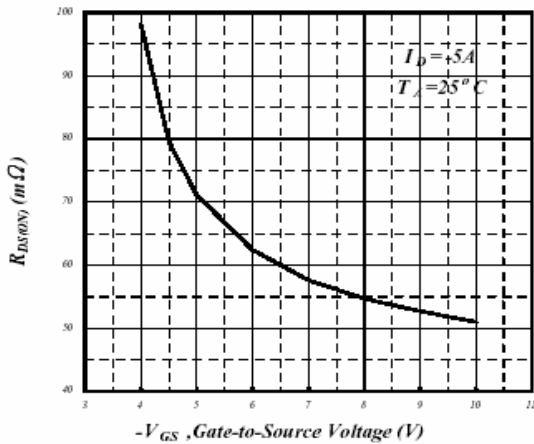
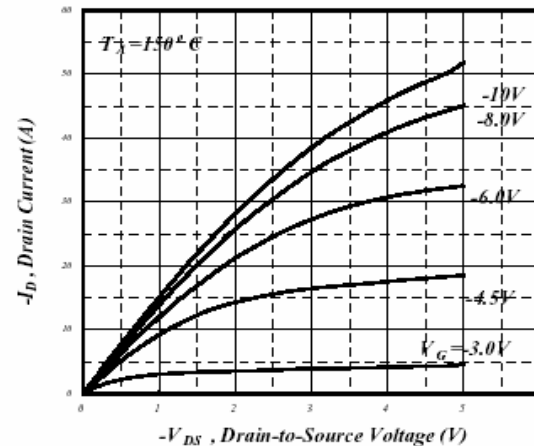
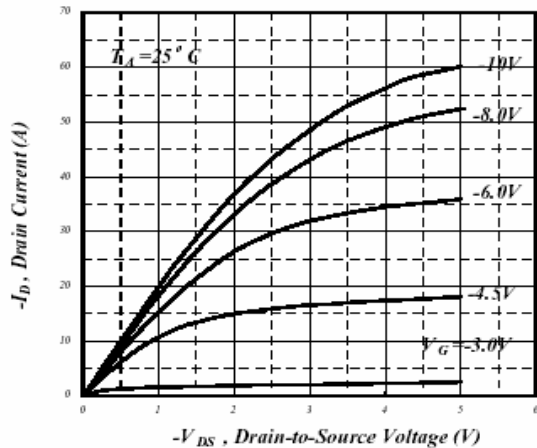



AF8510C

N AND P-CHANNEL ENHANCEMENT MODE POWER MOSFET

■ Typical Performance Characteristics (P-Channel) (Continued)

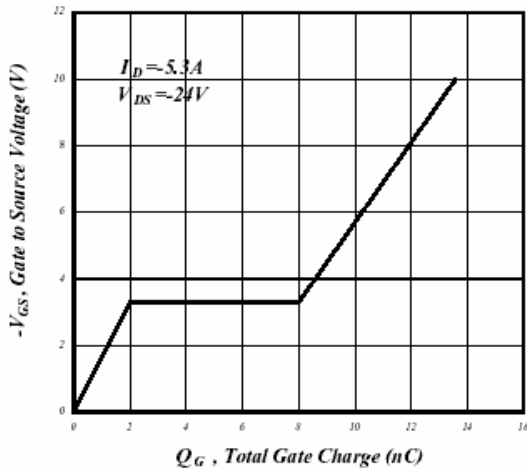

Fig 7. Gate Charge Characteristics

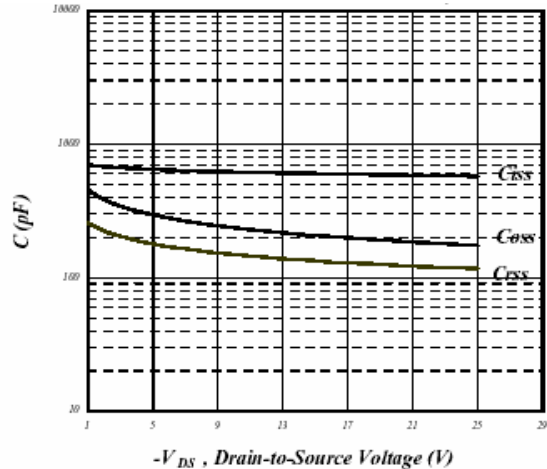

Fig 8. Typical Capacitance Characteristics

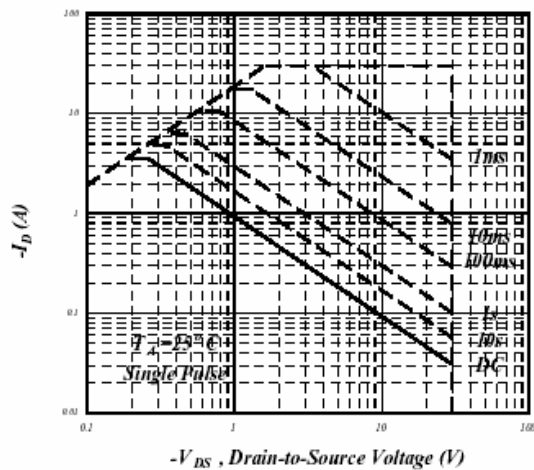

Fig 9. Maximum Safe Operation Area

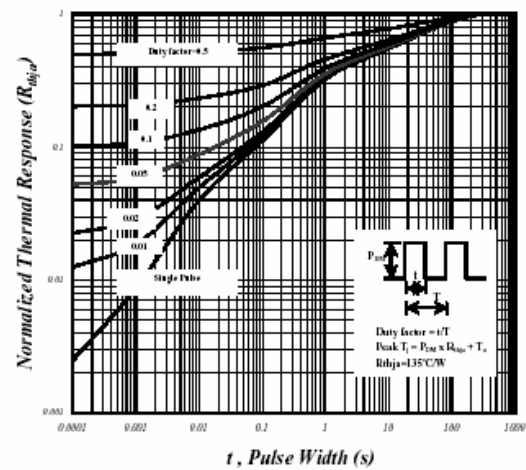

Fig 10. Effective Transient Thermal Impedance

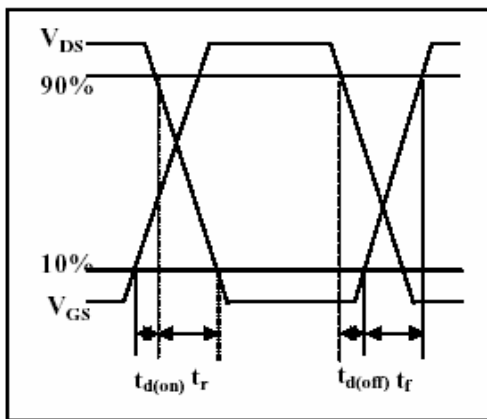

Fig 11. Switching Time Waveform

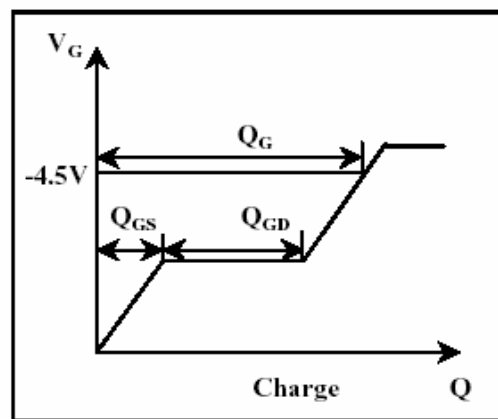

Fig 12. Gate Charge Waveform



AF8510C

N AND P-CHANNEL ENHANCEMENT MODE POWER MOSFET

■ Marking Information

SO-8L

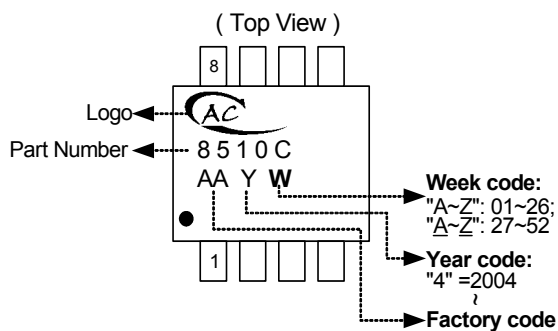

■ Package Information

Package Type: SO-8L

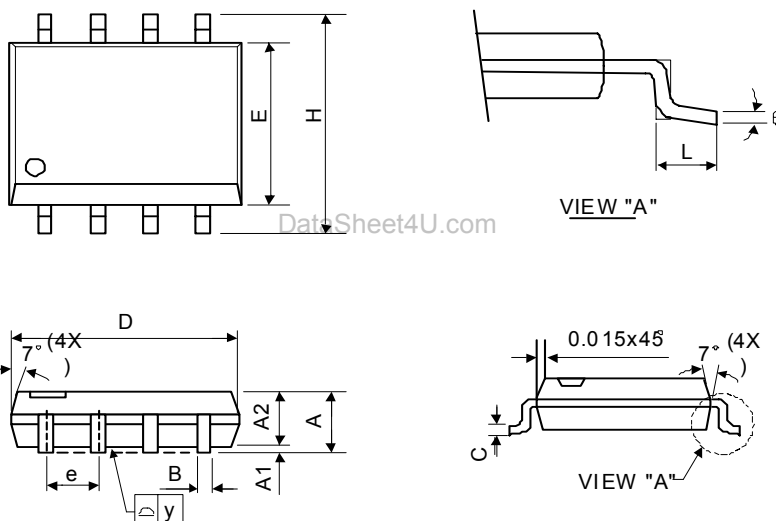

Symbol	Dimensions In Millimeters			Dimensions In Inches		
	Min.	Nom.	Max.	Min.	Nom.	Max.
A	1.40	1.60	1.75	0.055	0.063	0.069
A1	0.10	-	0.25	0.040	-	0.100
A2	1.30	1.45	1.50	0.051	0.057	0.059
B	0.33	0.41	0.51	0.013	0.016	0.020
C	0.19	0.20	0.25	0.0075	0.008	0.010
D	4.80	5.05	5.30	0.189	0.199	0.209
E	3.70	3.90	4.10	0.146	0.154	0.161
e	-	1.27	-	-	0.050	-
H	5.79	5.99	6.20	0.228	0.236	0.244
L	0.38	0.71	1.27	0.015	0.028	0.050
y	-	-	0.10	-	-	0.004
	0°	-	8°	0°	-	8°