



**SPECIFICATION  
FOR  
TFT MODULE**

**MODULE NO: AFA240320M-2.8-A8  
REVISION NO: 00**

Customer's Approval:

--

	SIGNATURE	DATE
PREPARED BY (RD ENGINEER)		
CHECKED BY		
APPROVED BY		

## Table of Contents

1.0	General Description	3
2.0	Electrical Characteristics	3
3.0	Mechanical Parameters	3
4.0	Pin Definition	3
5.0	Interface Design	4
6.0	Control Command	4
7.0	Outline Drawing	7
8.0	User's Guide	8
9.0	Reliability Test Items	10
10.0	Package Specification	10

Easy TFT is target to the users updating their product from monochrome LCD to TFT displays or new products fast developing, our solution can provides a simple and reliable way to control TFT displays. M7-M series include small screen with CPU port from 2.3" to 3.5" as well as screen with RGB port from 3.5" to 7", meeting the requirements for various applications from customers.

## 1.0 General Description

1. The bottle neck of MCU speed is solved: compared with the black and white module, the data volume of color screen is much larger and requires rapid data refresh while updating interface, which cannot be satisfied by traditional MCU, otherwise the responding speed of whole system will be very slow.
2. The data storage space of common MCU is within 64K, which is not enough to store one picture for TFT displays; our module adopts an 2Mbyte-8Mbyte FLASH to store picture data and this is quite enough for common interface design.
3. The technology of TFT displays change quickly and the driver IC updating fast, the product life time can't be guaranteed. The software and hardware is required to change often in order to adopt the new displays, which brings a lot of extra work. Our solution can help customer to solve the problem, when there is screen change, we can adopt it on our mainboard, the consumer don't need to changing their software and hardware.
4. The adoption of alphabetic string command for module control is simple and clear; only need MCU output "Hello World" from the UART
5. The RAM on the module is virtualized as a USB flash disk, the user copy pictures from computer to the module, saving a lot of work like general modeling and compiling etc. and development time is shortened.

## 2.0 Electrical Parameters:

Name	spec	note
Input voltage	5V±5%	
Current	<180mA	Backlight on
Color Depth	65K colors	
Operating Temperature	-20----70°C	
Storage Temperature	-30----80°C	
Luminance	300cd/m <sup>2</sup> (type)	
Display Mode	Transmissive	

## 3.0 Mechanical Parameters (mm)

ITEM	spec	note
Size of panel	69.20*50.00	240*320 Dots
Size of module	78.60*63.20*13max	
Size (VA)	58.80*44.30	

## 4.0 Pin Definition

J1 on module is communication port and K1 is reset key.

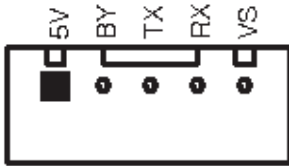

## 5.0 Interface Design:

1. Firstly, put all pictures needed into the folder of BMP\_FILE, convert them into BMP format and change picture names in proper sequence from 000.BMP. The operation can be completed with software of ACDSEE; see [Appendix I](#) for details in operation.

The picture files with names in proper sequence are shown in figure below:

000. bmp	83 KB	Windows Bitmap	240x117x24b
001. bmp	83 KB	Windows Bitmap	240x117x24b
002. bmp	83 KB	Windows Bitmap	240x117x24b
003. bmp	83 KB	Windows Bitmap	240x117x24b
004. bmp	83 KB	Windows Bitmap	240x117x24b
005. bmp	83 KB	Windows Bitmap	240x117x24b
006. bmp	282 KB	Windows Bitmap	240x400x24b

2. Execute batch processing command MakeDAT.bat and three files will be generated in the folder of BMP\_DATA after execution, among which BMPDATA.BIN is the data file where all picture data are put successively and TABLE.BIN is the table file equivalent to index file; copy these two files into the folder virtualized by the module and then they are available for use. There are picture serial numbers and corresponding information of picture size in the file of BmpDataBin.h, which is a reference provided to user without the necessity of being copied to USB flash disk.

3. If special character display is required by user, like Chinese or Japanese etc. The software attached in this module can be used for extracting font library; see [Appendix IV](#) for details. (Only for Chinese version)  
Revise the name of extracted font library file and copy it in to USB flash disk for application; the file name should be changed as HZK.BIN.

4. Note: this USB flash disk is a virtualized one; the file system is regulated for the convenience of application of this module and improvement of picture refreshing speed; please use FAT12 to format the USB flash disk (this is the default format in WinXP); the limit number of files in root directory is 16 and generally there are only font library file, table file and data file; if other files need to be stored by user, it had better to make a new folder for storage of these files.

5. Press K1 key (reset key) on module after all files are copied into USB flash disk and then they are available for use.

## 6.0 Control Command:

This module adopts alphabetic string to control all operations.

The command format begins with command word continued with parameter list in which parameters are separated by space and ends with a return character; pay attention that the return character is a must. *When the command is executing, the busy pin is low, and the module can't receive new command, until the busy pin is high.*

“CMD n1 n2.....Return”

The parameters n1, n2... in table below express a 16-bit unsigned integer data and s1, s2...expresses alphabetic string.

### Drawing commands

Function	Command Format	Example	Execution time
Browse Pictures	ALL	"ALL\n"	-
Draw a circle	CIRCLE Xa Ya R C	"CIRCLE 100 100 50 31\n"	4ms
Fill in color	CLR Xa Ya Xe Ye C	"CLR 0 0 100 100 31\n"	5ms
Clear screen	CLS C	"CLS 31\n"	28ms
Cut a picture	CUT Pn Xa Ya Xb Yb Xs Ys	"CUT 1 30 30 0 0 100 100\n"	20ms
Draw a dot	DOT Xa Ya C	"DOT 100 100 31\n"	0.12ms
Draw a frame with linetype and chamfer	FRAME Xa Ya Xe Ye Ds Do C	"FRAME 10 10 200 40 2 3 31\n"	4ms
Draw a line	LINE Xa Ya Xe Ye C	"LINE 10 10 50 50 31\n"	0.7ms
Backlight on	LEDON	"LEDON\n"	4us
Adjusting backlight luminance	LEDON X (X:1~10)	"LEDON10\n"	4us
Backlight off	LEDOFF	"LEDOFF\n"	4us
Animation	MOT Xa Ya Ps Pe Pt	"MOT 0 0 10 14 100\n"	0.15ms
Animation off	MOFF	"MOFF\n"	4us
Call on PIC	PIC Pn Xa Ya	"PIC 1 30 30\n"	125ms
Draw a rectangle	RECT Xa Ya Xe Ye C	"RECT 10 10 100 100 31\n"	5ms
Get screen size *	SIZE	"SIZE\n"	13ms
Display alphabetic string	STR Xa Ya C Str	"STR 0 0 31 ABCDEF\n"	0.8ms/Char
Display alphabetic string with background color	STB Xa Ya C Cb Str	"STB 0 20 65535 31 ABC\n"	30us/Char

**Note:**

Xa Ya :start x y coordinates

C :color(16bits,RGB 565 )

Xe Ye :End x y coordinates

Cb : Background color

Xb Yb : start end X Y coordinates in livelong PIC

Xs Ys : Need to intercept the size from livelong picture

Ds Do :Length of Solid line/Dotted line

Str :alphabetic string(8x16)

Pn : Pictures serial number(000-999)

R : Radius

Ps : Start animation picture number

Pe : End animation picture number

Pt : Spacing time(step :100ms)

\* Using the command ,there will be a return value format is a "SXY Xsize Ysize\n"

### Configure Commands

Function	Command Format	Example	Time
Set baud rate	BAUD b1 b2	"BAUD 9600 9600\n"	20ms
Demonstrate PIC	DEMO Dt Xa Ya	"DEMO 1000 0 0\n"	20ms
Off demonstrate	DMOFF	"DMOFF\n"	20ms
Change direction Display of panel	TURN Tn	"TURN 90\n"	140ms

**Note:**

b1 b2 denote baud rate

(range:2400,4800,9600,19200,38400,56000,57600,115200)

Dt denote DEMO interval(step 100ms)

Tn Rotation angle (0° 90°)

# 7.0 Outline Drawing

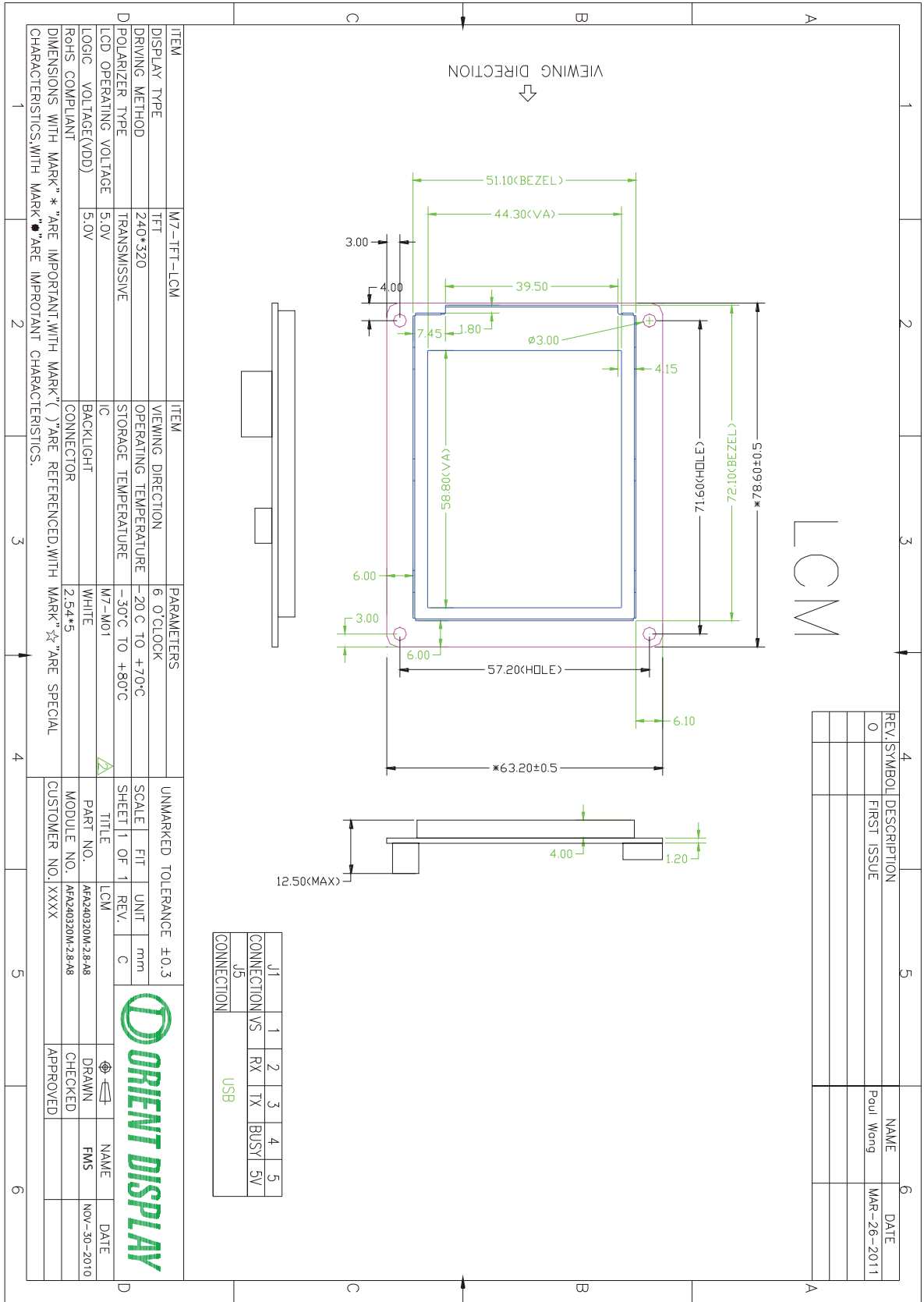

LCM

REV.	SYMBOL	DESCRIPTION	NAME	DATE
0		FIRST ISSUE	Pouli Wong	MAR-28-2011

J1	1	2	3	4	5
CONNECTION VS	RX	TX	BUSY	5V	
J5					
CONNECTION	USB				

ITEM	ITEM	PARAMETERS	UNMARKED TOLERANCE	SCALE	FIT	UNIT	REV.	C	ORIENT DISPLAY	NAME	DATE
ITEM	M7-TFT-LCM	VIEWING DIRECTION	±0.3			mm					
DISPLAY TYPE	TFT	6.0 CLOCK									
DRIVING METHOD	240*320	OPERATING TEMPERATURE									
POLARIZER TYPE	TRANSMISSIVE	-20°C TO +70°C									
LCD OPERATING VOLTAGE	5.0V	-30°C TO +80°C									
LOGIC VOLTAGE (VDD)	5.0V	M7-M01									
ROHS COMPLIANT	CONNECTOR	BACKLIGHT									
DIMENSIONS WITH MARK *		WHITE									
CHARACTERISTICS WITH MARK *		2.54*5									

## 8.0 User's Guide

### Appendix I

#### Application of ACDSEE for classifying pictures

1. Collect materials for use into the folder of BMP\_FILE; at the beginning, the pictures may be disordered and the processing of following steps is needed to make them in proper order for operation.



3. Sort the pictures successively beginning with 000.



5. Execute the batch file of MakeDAT.bat

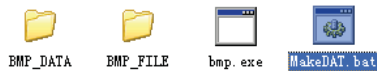

6. After execution, there are three files generated in BMP\_DATA, wherein BMPDATA.BIN is data file in which all picture data are put inside in order; TABLE.BIN is table file equivalent to index file. Copy these two files into the folder virtualized the module and then they are available for use. There are picture serial numbers in the file of BmpDataBin.h corresponding to picture size information as a reference provided to user which is unnecessary to be copied into USB flash disk.



2. Convert all files into BMP format.



4. Reorder the special picture sequence, for instance, the animation part and special font part must be continuous.





## Appendix II

### Application circuit

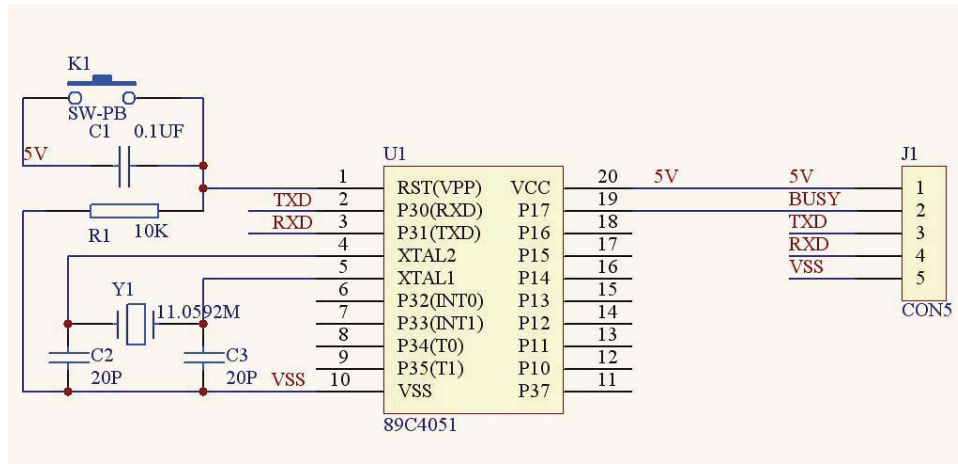

## Appendix III



## 9.0 Reliability Test Items

No	Item	Condition	Quantity
1	High Temperature Operating	70°C, 96Hrs	5
2	Low Temperature Operating	-20°C, 96Hrs	5
3	High Humidity	60°C, 90%RH, 96Hrs	5
4	High Temperature Storage	80°C, 96Hrs	5
5	Low Temperature Storage	-40°C, 96Hrs	5
6	Thermal shock	-20°C, 30min~70°C, 30min, 20 cycles.	5

Note1. No deflection cosmetic and operational function allowable.

## 10.0 Package Specification TBD