



General Description

AFC2517W, N & P Pair enhancement mode MOSFET, uses Advanced Trench Technology to provide excellent $R_{DS(ON)}$, low gate charge.

These devices are particularly suited for low voltage power management, and low in-line power loss are needed in commercial industrial surface mount applications.

Features

- N-Channel
20V/4.6A, $R_{DS(ON)}=25m\Omega@V_{GS}=4.5V$
20V/4.2A, $R_{DS(ON)}=30m\Omega@V_{GS}=2.5V$
20V/3.8A, $R_{DS(ON)}=38m\Omega@V_{GS}=1.8V$
- P-Channel
-20V/-3.6A, $R_{DS(ON)}=52m\Omega@V_{GS}=4.5V$
-20V/-3.2A, $R_{DS(ON)}=65m\Omega@V_{GS}=2.5V$
-20V/-1.2A, $R_{DS(ON)}=82m\Omega@V_{GS}=1.8V$
- Super high density cell design for extremely low $R_{DS(ON)}$
- Exceptional on-resistance and maximum DC current capability
- DFN2X2-6L package design

Pin Description (DFN2X2-6L)

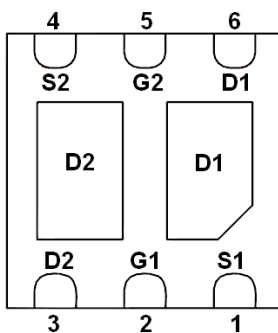

BOTTOM VIEW

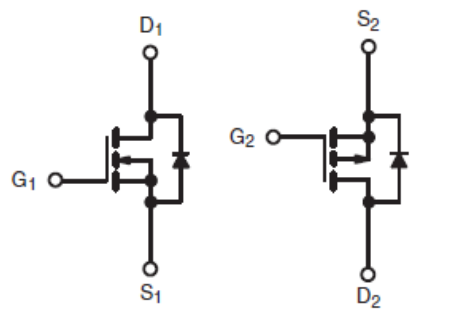

N-Channel MOSFET P-Channel MOSFET

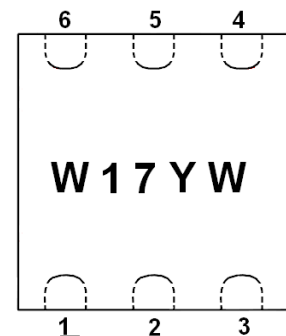

TOP VIEW

Application

- Portable Devices Such as Smart Phones, Tablet PCs and Mobile Computing
 - Load Switches
 - Power Management
 - DC/DC Converters



Pin Define

Pin	Symbol	Description
1	S1	Source1
2	G1	Gate1
3	D2	Drain2
4	S2	Source2
5	G2	Gate2
6	D1	Drain1

Ordering Information

Part Ordering No.	Part Marking	Package	Unit	Quantity
AFC2517WFN226RG	W17YW	DFN2X2-6L	Tape & Reel	4000 EA

- ※ W17 parts code
- ※ Y year code
- ※ W week code
- ※ AFC2517WFN226RG : 7" Tape & Reel ; Pb- Free ; Halogen- Free

Absolute Maximum Ratings

(T_A=25°C Unless otherwise noted)

Parameter	Symbol	Typical		Unit	
		N-Channel	P-Channel		
Drain-Source Voltage	V _{DSS}	20	-20	V	
Gate –Source Voltage	V _{GSS}	±12	±12	V	
Continuous Drain Current(T _J =150°C)	I _D	T _c =25°C	4.2	-4.2	A
		T _c =70°C	4.2	-4.2	
Pulsed Drain Current	I _{DM}	15	-15	A	
Continuous Source Current(Diode Conduction)	I _S	1.6	-1.6	A	
Power Dissipation	P _D	7.8		W	
		5.0			
Operating Junction Temperature	T _J	150		°C	
Storage Temperature Range	T _{STG}	-55/150		°C	
Thermal Resistance-Junction to Ambient	R _{θJA}	52	52	°C/W	
Thermal Resistance-Junction to Case(Drian)	R _{θJc}	12.5	12.5		



Electrical Characteristics (N-Channel)

(T_A=25°C Unless otherwise noted)

Parameter	Symbol	Conditions	Min.	Typ	Max.	Unit
Static						
Drain-Source Breakdown Voltage	V _{(BR)DSS}	V _{GS} =0V, I _D =250uA	20			V
Gate Threshold Voltage	V _{GS(th)}	V _{DS} =V _{GS} , I _D =250uA	0.4		1.0	V
Gate Leakage Current	I _{GSS}	V _{DS} =0V, V _{GS} =±12V			±100	nA
Zero Gate Voltage Drain Current	I _{DSS}	V _{DS} =16V, V _{GS} =0V			1	uA
		V _{DS} =16V, V _{GS} =0V T _J =85°C			10	
On-State Drain Current	I _{D(on)}	V _{DS} ≥5V, V _{GS} =4.5V	10			A
Drain-Source On-Resistance	R _{DS(on)}	V _{GS} =4.5V, I _D =4.6A		16	25	mΩ
		V _{GS} =2.5V, I _D =4.2A		20	30	
		V _{GS} =1.8V, I _D =2.8A		27	38	
Forward Transconductance	g _{FS}	V _{DS} =10V, I _D =4.6A		21		S
Diode Forward Voltage	V _{SD}	I _S =1.5A, V _{GS} =0V		0.85	1.2	V
Dynamic						
Total Gate Charge	Q _g	V _{DS} =10V, V _{GS} =4.5V I _D ≅5.9A		6.0	12	nC
Gate-Source Charge	Q _{gs}			0.75		
Gate-Drain Charge	Q _{gd}			0.85		
Input Capacitance	C _{iss}	V _{DS} =6V, V _{GS} =0V f=1MHz		480		pF
Output Capacitance	C _{oss}			120		
Reverse Transfer Capacitance	C _{rss}			75		
Turn-On Time	t _{d(on)}	V _{DD} =6V, R _L =1.3Ω I _D ≅4.8A, V _{GEN} =4.5V R _G =1Ω		10	20	ns
	t _r			10	20	
Turn-Off Time	t _{d(off)}			20	40	
	t _f			10	20	



Electrical Characteristics (P-Channel)

(T_A=25°C Unless otherwise noted)

Parameter	Symbol	Conditions	Min.	Typ	Max.	Unit	
Static							
Drain-Source Breakdown Voltage	V _{(BR)DSS}	V _{GS} =0V, I _D =-250uA	-20			V	
Gate Threshold Voltage	V _{GS(th)}	V _{DS} =V _{GS} , I _D =-250uA	-0.4		-1.0		
Gate Leakage Current	I _{GSS}	V _{DS} =0V, V _{GS} =±8V			±10	uA	
Zero Gate Voltage Drain Current	I _{DSS}	V _{DS} =-16V, V _{GS} =0V			-1	uA	
		V _{DS} =-16V, V _{GS} =0V T _J =85°C			-10		
On-State Drain Current	I _{D(on)}	V _{DS} ≥-5V, V _{GS} =-4.5V	-10			A	
Drain-Source On-Resistance	R _{DS(on)}	V _{GS} =-4.5V, I _D =-3.6A		42	52	mΩ	
		V _{GS} =-2.5V, I _D =-3.2A		55	65		
		V _{GS} =-1.8V, I _D =-1.2A		69	82		
Forward Transconductance	g _{FS}	V _{DS} =-10V, I _D =-3.6A		11		S	
Diode Forward Voltage	V _{SD}	I _S =-1.25A, V _{GS} =0V		-0.85	-1.2	V	
Dynamic							
Total Gate Charge	Q _g	V _{DS} =-6V, V _{GS} =-4.5V I _D ≡-4.3A		9	20	nC	
Gate-Source Charge	Q _{gs}			1.2			
Gate-Drain Charge	Q _{gd}			2.8			
Input Capacitance	C _{iss}	V _{DS} =-6V, V _{GS} =0V f=1MHz		600		pF	
Output Capacitance	C _{oss}			280			
Reverse Transfer Capacitance	C _{rss}			250			
Turn-On Time	t _{d(on)}	V _{DD} =-6V, R _L =1.6Ω I _D ≡-3.8A, V _{GEN} =-4.5V		30	55	ns	
	t _r			25	45		
Turn-Off Time	t _{d(off)}		R _G =1Ω		30		55
	t _f				20		40



Typical Characteristics (N-Channel)

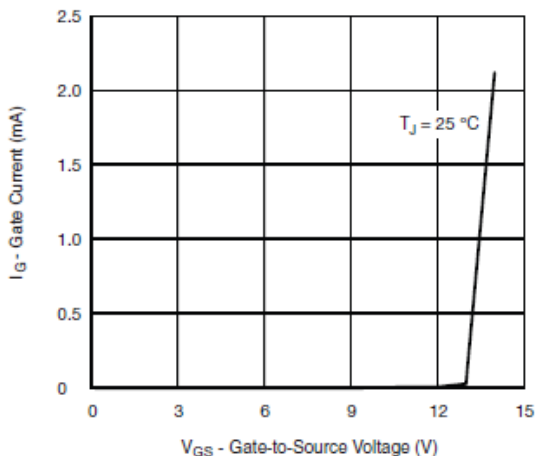

Gate Current vs. Gate-Source Voltage

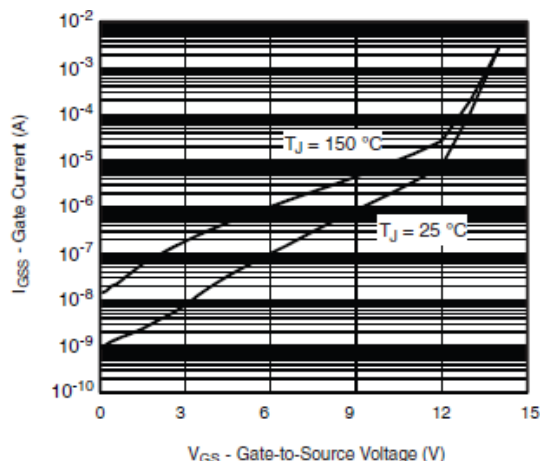

Gate Current vs. Gate-Source Voltage

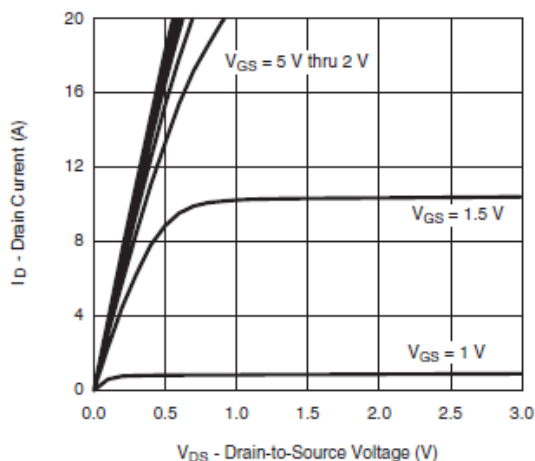

Output Characteristics

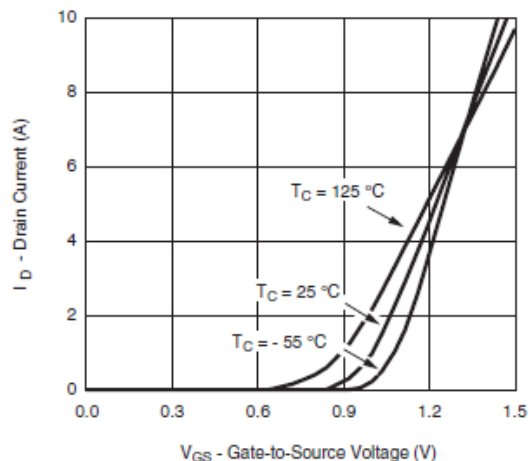

Transfer Characteristics

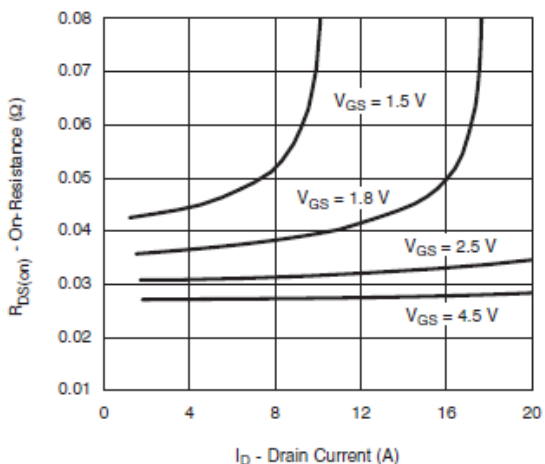

On-Resistance vs. Drain Current and Gate Voltage

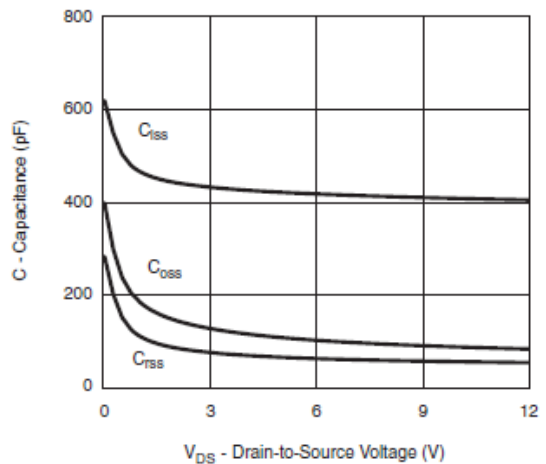

Capacitance



Typical Characteristics (N-Channel)

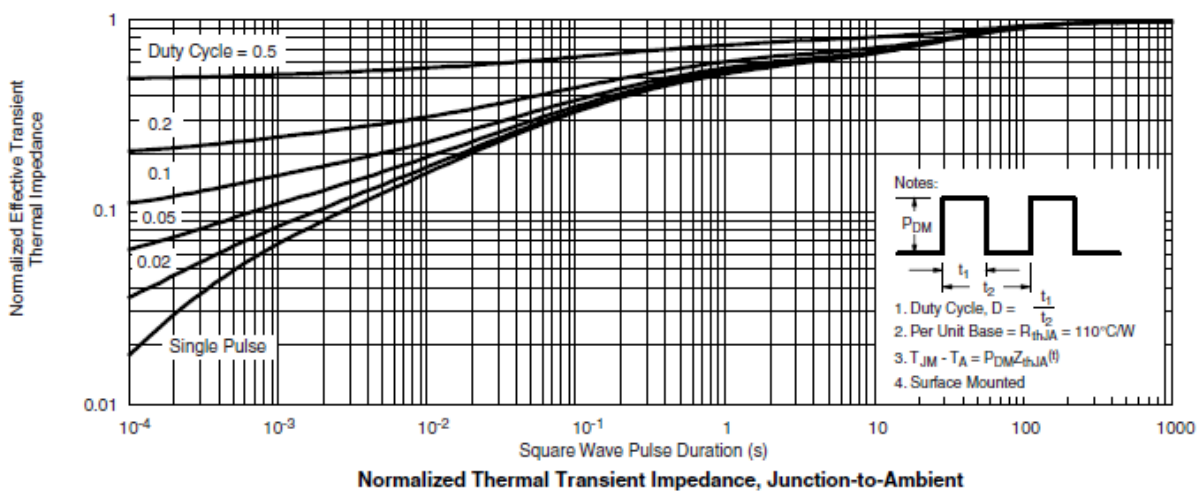
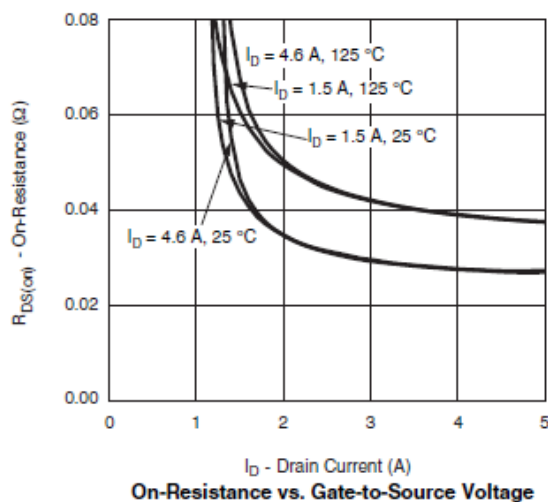
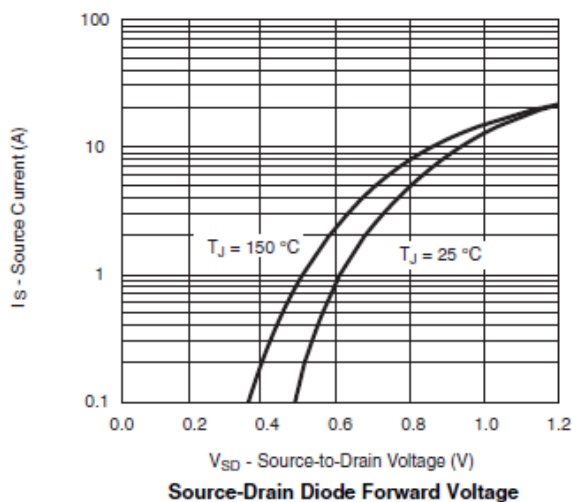
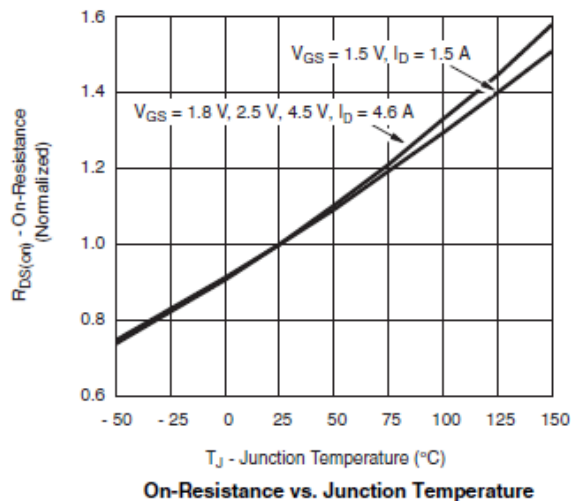
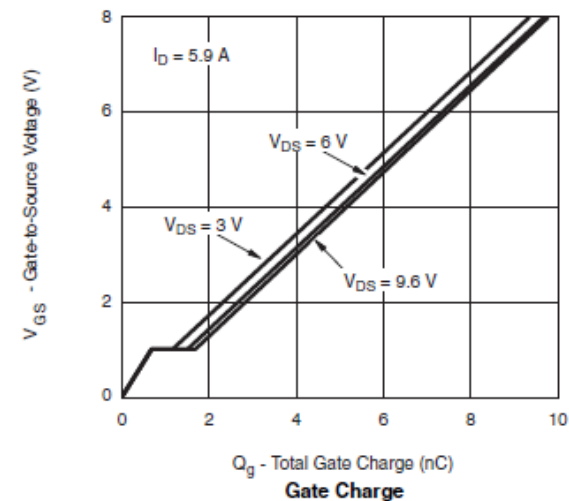



Typical Characteristics (N-Channel)

Gate Charge Test Circuit & Waveform

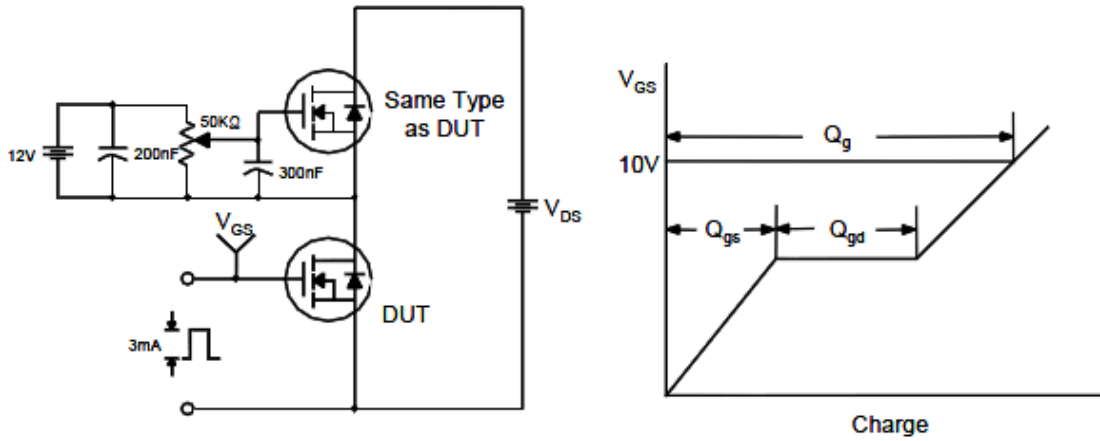

Resistive Switching Test Circuit & Waveforms

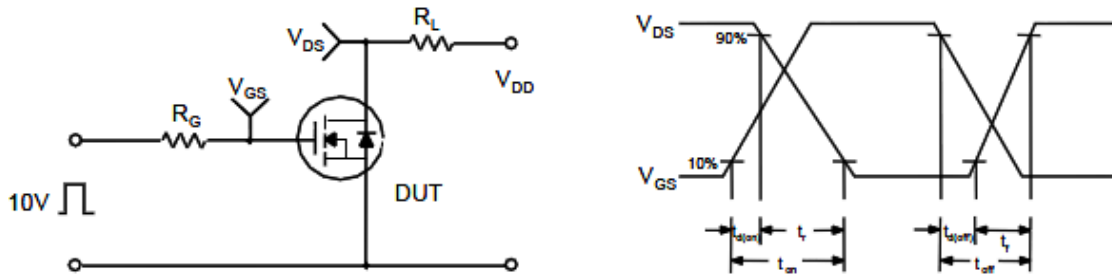

Unclamped Inductive Switching Test Circuit & Waveforms

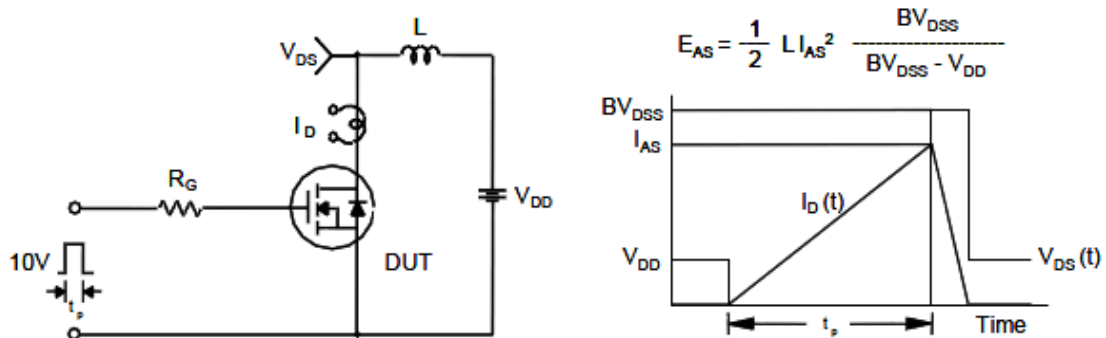



Typical Characteristics (P-Channel)

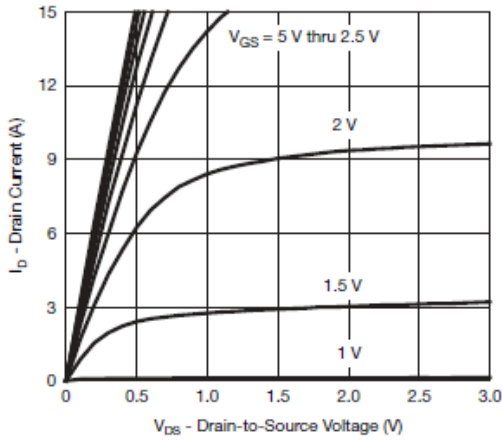

Output Characteristics

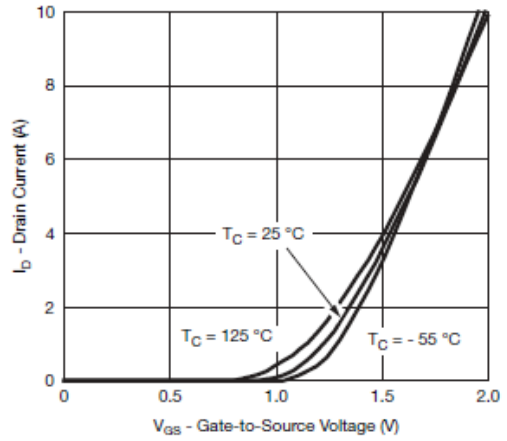

Transfer Characteristics

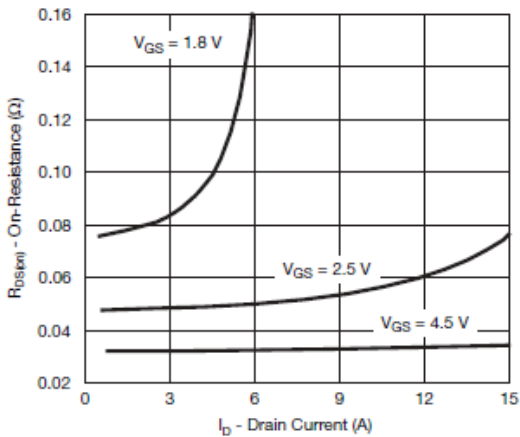

On-Resistance vs. Drain Current and Gate Voltage

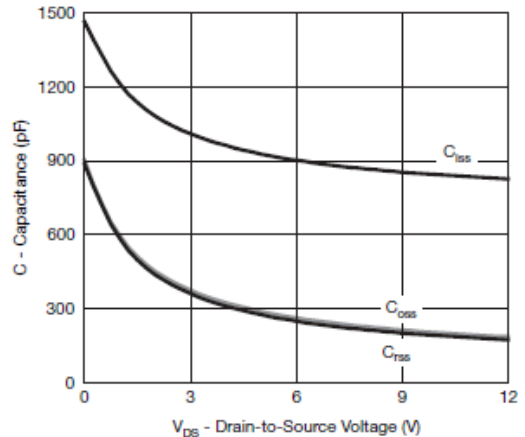

Capacitance

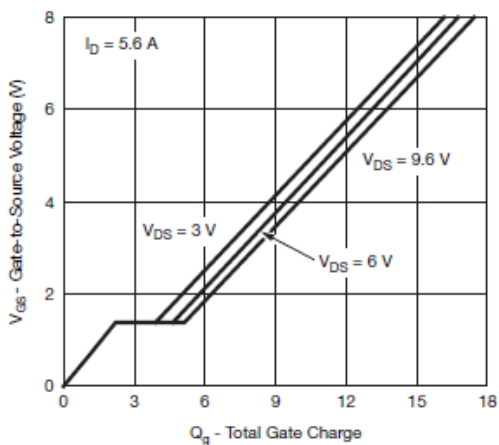

Gate Charge

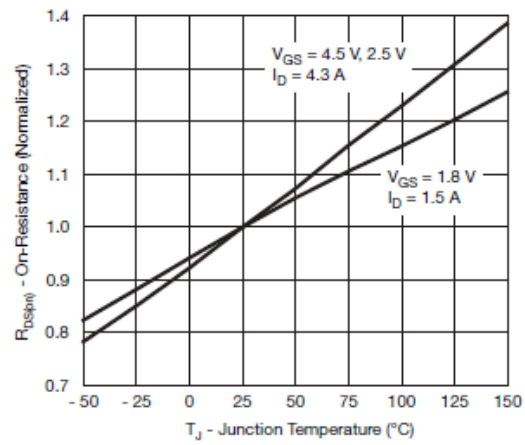

On-Resistance vs. Junction Temperature



Typical Characteristics (P-Channel)

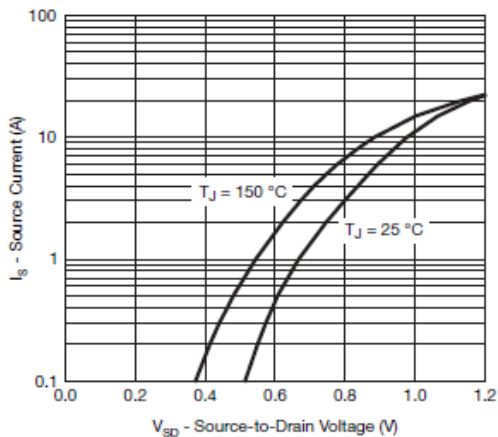

Source-Drain Diode Forward Voltage

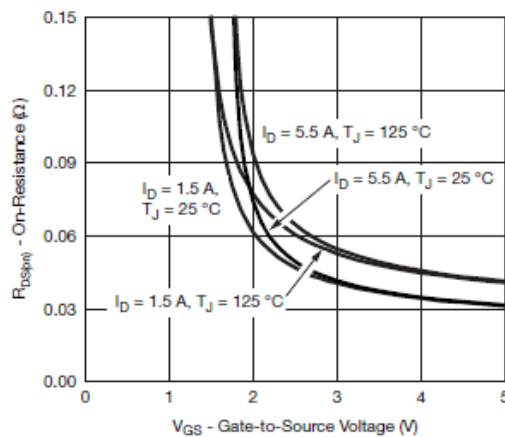

On-Resistance vs. Gate-to-Source Voltage

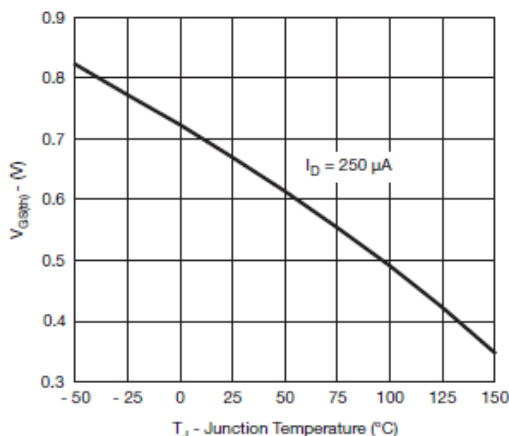

Threshold Voltage

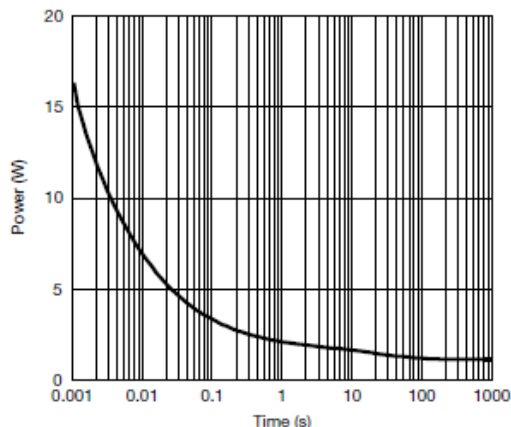

Single Pulse Power, Junction-to-Ambient

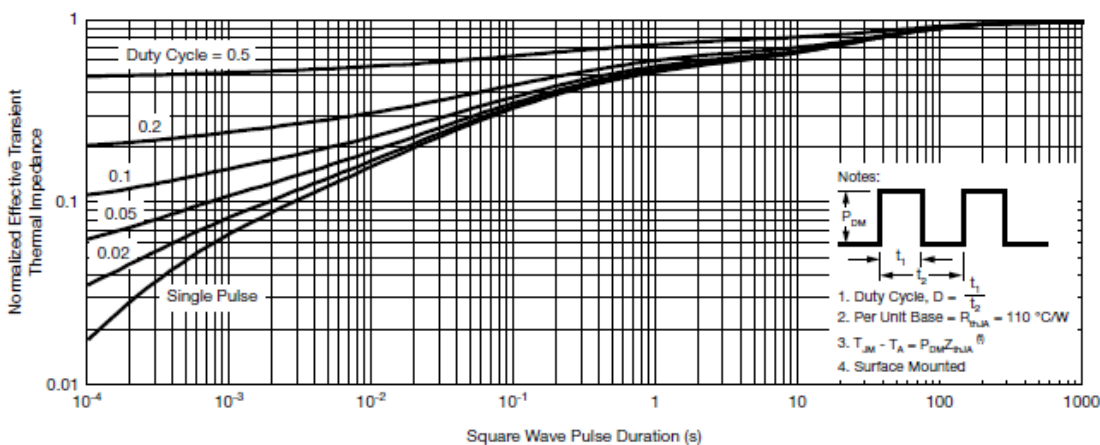

Normalized Thermal Transient Impedance, Junction-to-Ambient



Typical Characteristics (P-Channel)

Gate Charge Test Circuit & Waveform

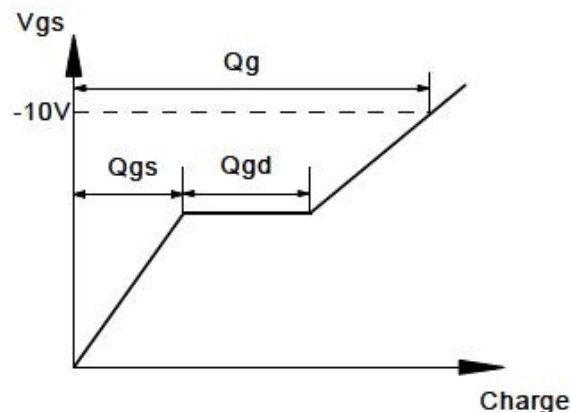
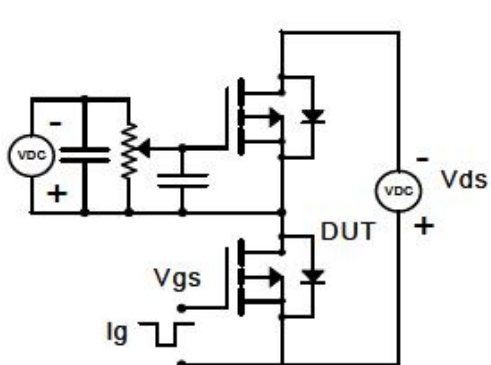

Resistive Switching Test Circuit & Waveforms

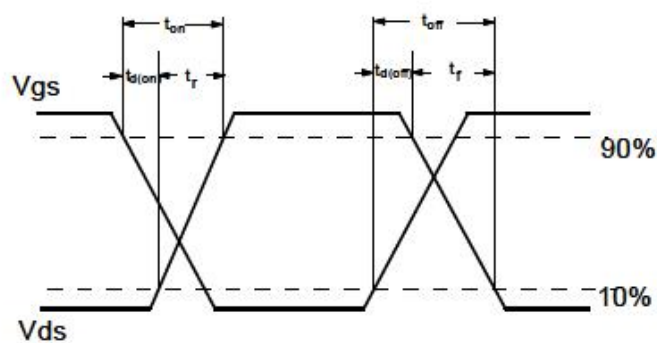
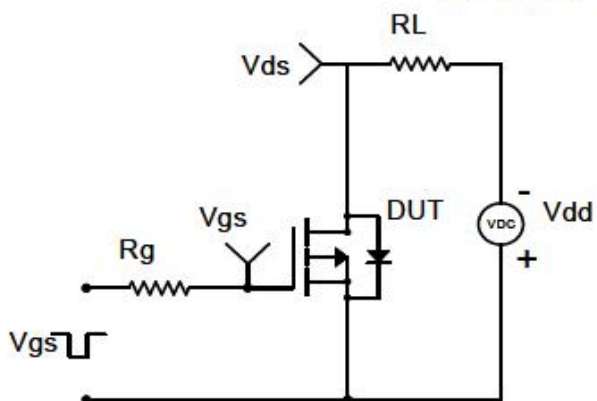

Diode Recovery Test Circuit & Waveforms

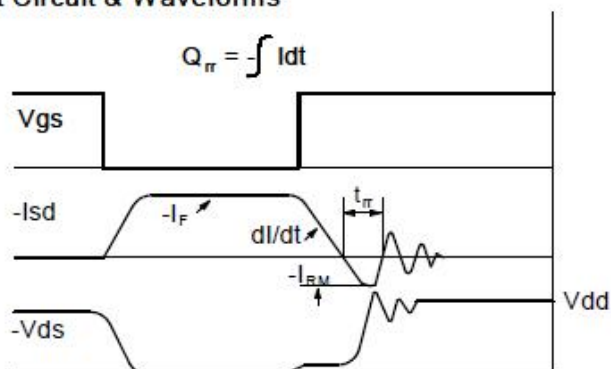
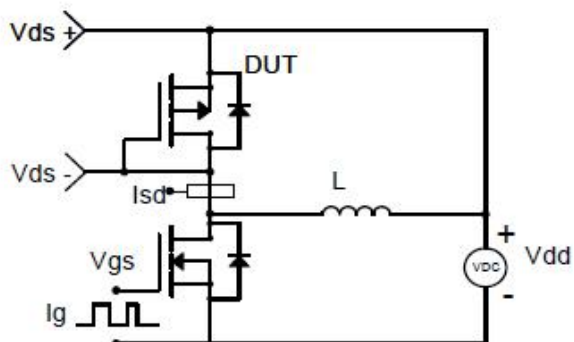



Package Information (DFN2X2-6L)

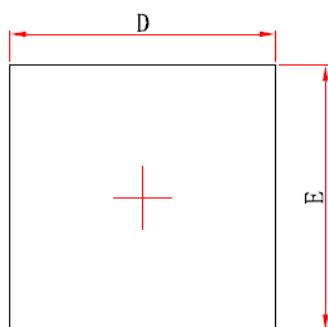

Top View

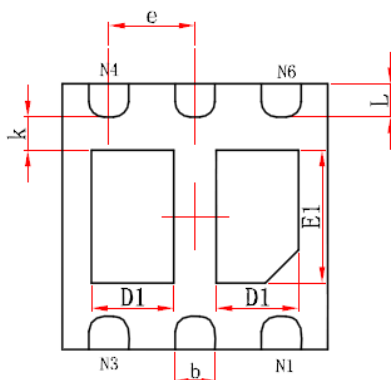

Bottom View

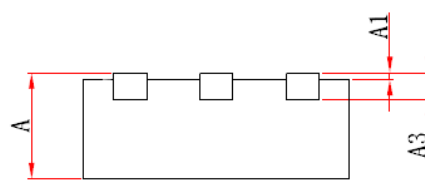

Side View

Symbol	Dimensions In Millimeters		Dimensions In Inches	
	Min.	Max.	Min.	Max.
A	0.700/0.800	0.800/0.900	0.028/0.031	0.031/0.035
A1	0.000	0.050	0.000	0.002
A3	0.203REF.		0.008REF.	
D	1.924	2.076	0.076	0.082
E	1.924	2.076	0.076	0.082
D1	0.520	0.720	0.020	0.028
E1	0.900	1.100	0.035	0.043
k	0.200MIN.		0.008MIN.	
b	0.250	0.350	0.010	0.014
e	0.650TYP.		0.026TYP.	
L	0.174	0.326	0.007	0.013

©2010 Alfa-MOS Technology Corp.
2F, No.80, Sec.1, Cheng Kung Rd., Nan Kang Dist., Taipei City 115, Taiwan (R.O.C.)
Tel : 886 2) 2651 3928
Fax : 886 2) 2786 8483
©http://www.alfa-mos.com