

AFC461 Series

PD-94585C

EMI Filter

Hybrid – High Reliability

40V Max Input, Single Output

Features

- 4.0A Maximum input current
- 40dB noise reduction min. @100 kHz
- -55°C to +125°C operation
- Military screening
- Compatible with ATW, AHE, ATO, ATR and AHF series DC-DC converters
- No Derating for -55°C to +125°C operation
- No tantalum capacitors for high reliability
- Standard microcircuit drawings available

Product Summary

- **Part number:** AFC461/CH (91020-01HXA), AFC461F/CH (91020-01HZA)

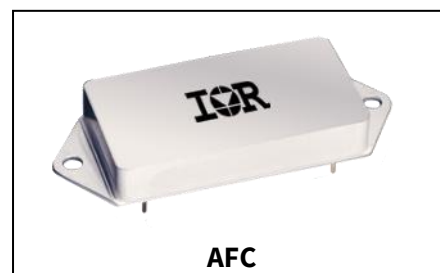

Potential Applications

- DC-DC converter

Product Validation

Validated according to MIL-PRF-38534 for high-reliability applications

Ordering Information

Table 1 Ordering Information

Part number	Package	Screening Level
AFC461/CH	AFC	COTS
AFC461F/CH	AFC	COTS
91020-01HXA	AFC	MIL-PRF-38534
91020-01HZA	AFC	MIL-PRF-38534

AFC461 Series

40V Max Input, Single Output

Description

Description

The AFC461 EMI filter will reduce the input line reflected ripple current of the AHV, ATO, ATW, ATR, and AHF line of DC-DC converters to levels below the CEO3 limits of MIL-STD-461. These EMI filters are manufactured in a facility certified to MIL-PRF-38534. All purposes used to manufacture these filters have been qualified to enable IR HiRel to deliver compliant devices. Three standard temperature grades are offered with screening options. Manufactured in a facility fully qualified to MIL-PRF-38534, these EMI filters are fabricated utilizing DSCC qualified processes. For available screening options, refer to device screening table in the datasheet.

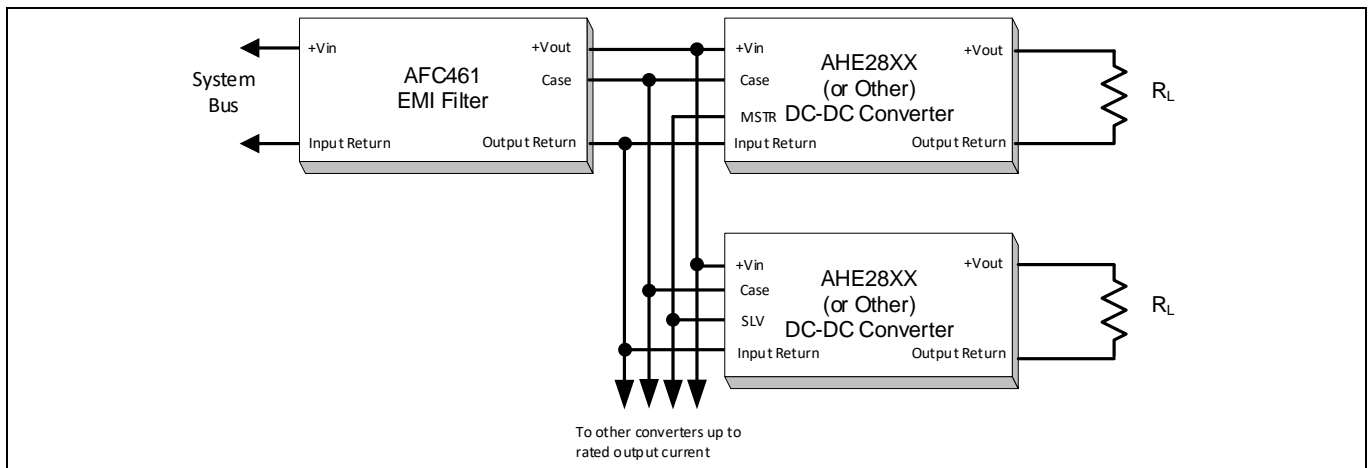

Figure 1 Typical Application Block Diagram

Table of contents

Table of contents

Product Summary	1
Features	1
Potential Applications	1
Product Validation	1
Ordering Information	1
Description	2
Table of contents	3
1 Block Diagram	4
Device Synchronization	4
2 Pin Designation	5
3 SPECIFICATION	6
3.1 Specification.....	6
3.2 Standard Microcircuit Drawing Equivalence Table.....	6
4 Mechanical Outlines	7
5 Devices Screening	8
6 Part Numbering	9
Revision history	10

AFC461 Series

40V Max Input, Single Output

Block Diagram

1 Block Diagram

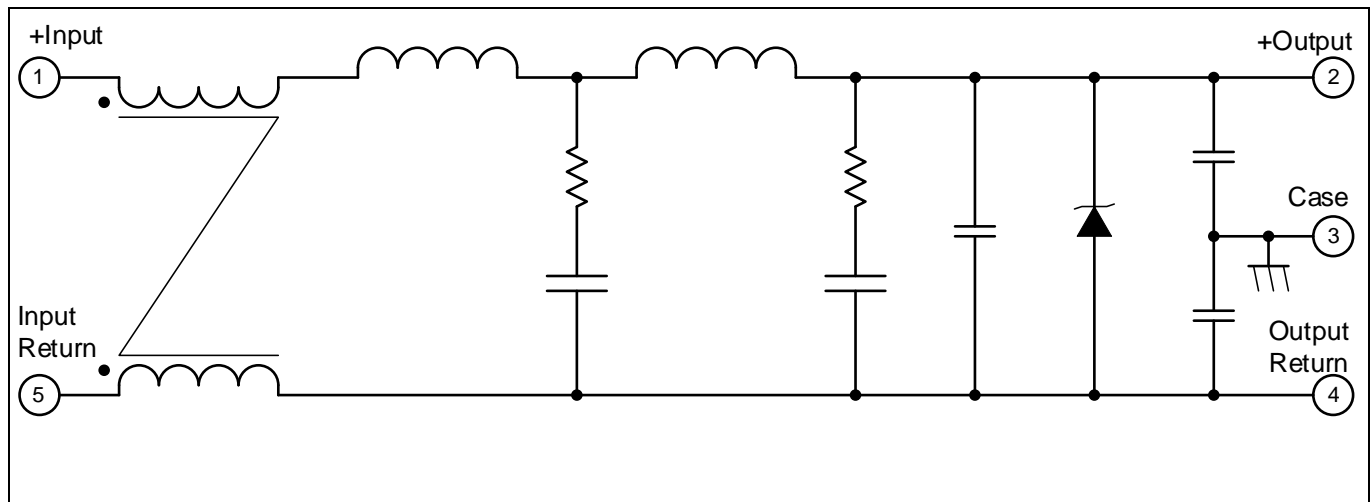

Figure 2 Block Diagram

Refer to page 5 for Pin Designation Table

Device Synchronization

Whenever multiple DC-DC converters are utilized in a single system, significant low frequency noise may be generated due to slight difference in the switching frequencies of the converters (beat frequency noise). because of the low frequency nature of this noise (typically less than 10KHz), it is difficult to filter out and may interfere with proper operation of sensitive systems (communications, radar or telemetry). IR HiRel offers an option, which provides synchronization of multiple AHE/ATW type converters, thus eliminating this type of noise. To take advantage of this capability, the system designer must assign one of the converters as the master. Then, by definition, the remaining converters become slaves and will operate at the masters' switching frequency. The user should be aware that the synchronization system is fail-safe; that is, the slaves will continue operating should the master frequency be interrupted for any reason. The layout must be such that the synchronization output of the master device is connected to the synchronization input of each slave device. It is advisable to keep this run short to minimize the possibility of radiating the 250KHz switching frequency. A typical connection is illustrated on the cover sheet of this document.

The appropriate converters must be ordered to take advantage of this feature. After selecting the converters required for the system, a 'MSTR' suffix is added for the master converter part number and an 'SLV' suffix is added for slave part number. See Part Number section of the applicable converter data sheets.

Pin Designation

2 Pin Designation

Table 2 Pin Designation

Pin Number	Designation
1	+ Input
2	+ Output
3	Case Ground
4	Output Return
5	Input Return

AFC461 Series

40V Max Input, Single Output

Specification

3 Specification

3.1 Specification

Table 3 Specification

Parameter	Conditions	Limits			Unit
		Min	Nom	Max	
Input voltage	Steady state	0	28	40	V
Input current	DC			4.0	A
	Ripple			1.0	A _{RMS}
Input clamping voltage	-55°C	38.9	43.2	47.5	V
	+25°C	42.3	47.0	51.7	
	+125°C	44.9	49.9	54.8	
Output voltage ¹	Steady state	$V_{OUT} = V_{IN} - I_{IN} (R_{DC})$			W
Output current	Steady state			4.0	A
DC Resistance (R _{DC})	Steady state	0.07	0.10	0.15	Ω
Power Dissipation	Max. DC current			2.4	W
Noise Reduction	100 KHz to 50 MHz	40			dB
Capacitance	Any pin to case			4200	pF
Isolation	Any pin to case 500V _{DC}	100			M Ω
Operating Temperature	Case	-55		+125	°C
Storage Temperature	Case	-65		+150	
Weight				55	g

3.2 Standard Microcircuit Drawing Equivalence Table

Table 4 Standard Microcircuit Drawing Equivalence

Standard microcircuit drawing number	Vendor cage code	Standard Part number
91020-01HXA	52467	AFC461/CH
91020-01HZA	52469	AFC461F/CH

¹ Typical applications result in V_{out} within 2 % of V_{in}

AFC461 Series

40V Max Input, Single Output

Mechanical Outlines

4 Mechanical Outlines

Note: For the most updated package outline, please see the website: AFC461

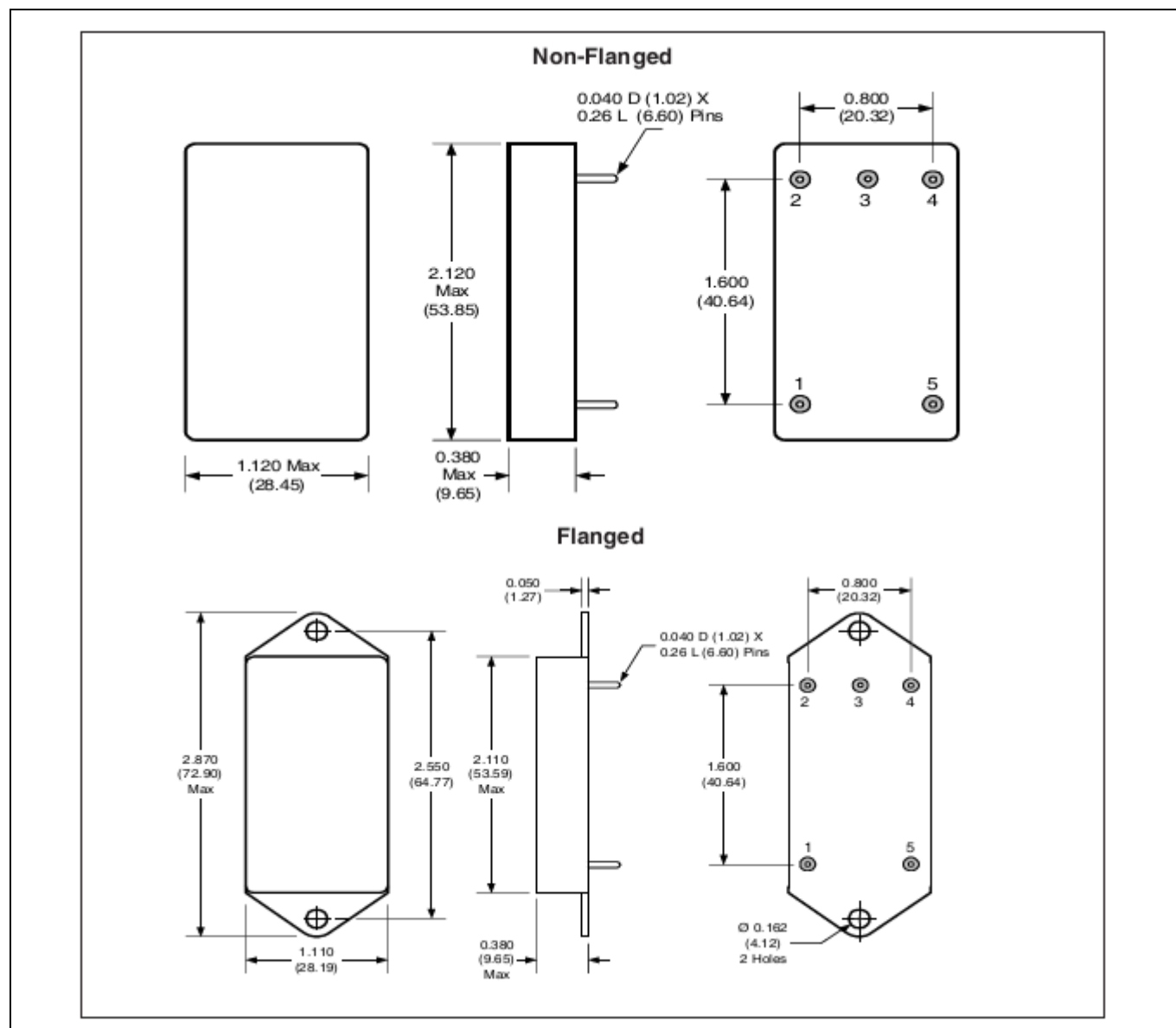

Figure 3 Package outline

AFC461 Series

40V Max Input, Single Output

Device Screening

5 Device Screening

Requirement	MIL-STD-883 Method	No Suffix	ES ^②	HB	CH
Temperature range		-20 to +85°C	-55°C to +125°C	-55°C to +125°C	-55°C to +125°C
Element evaluation	MIL-PRF-38534		NA	NA	Class H
Non-Destructive bond pull	2023	NA	NA	NA	NA
Internal Visual	2017	①	Yes	Yes	Yes
Temperature cycle	1010	NA	Cond B	Cond C	Cond C
Constant acceleration	2001, Y1 Axis	NA	500Gs	3000Gs	3000Gs
PIND	2020	NA	NA	NA	NA
Burn-in	1015	NA	48hrs @ 125°C	160hrs @ 125°C	160hrs @ 125°C
Final electrical (Group A)	MIL-PRF-38534 & Specification	25°C	25°C	-55, +25, +125°C	-55, +25, +125°C
PDA	MIL-PRF-38534	NA	NA	NA	10%
Seal, Fine & Gross	1014	Cond A	Cond A, C	Cond A, C	Cond A, C
Radiographic	2012	NA	NA	NA	NA
External visual	2009	①	Yes	Yes	Yes

Notes:

① Best commercial practice

② Sample tests at low and high temperatures

AFC461 Series

40V Max Input, Single Output

Part Numbering

6 Part Numbering

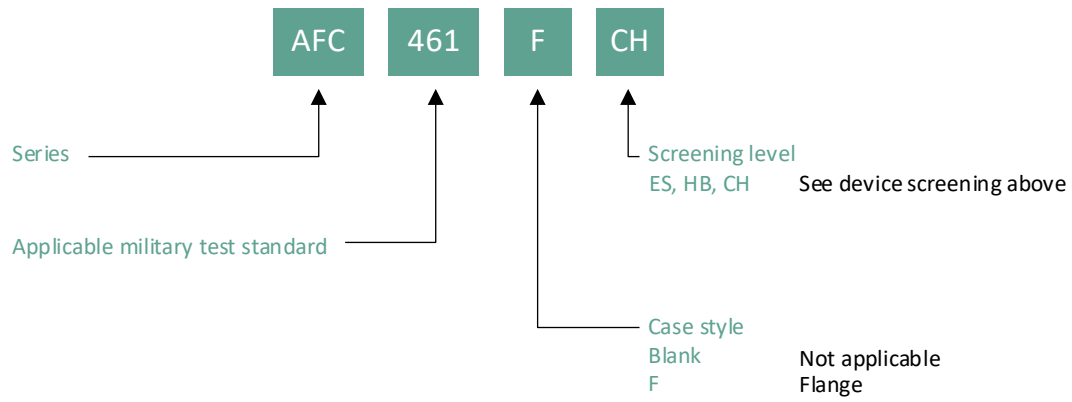

AFC461 Series

40V Max Input, Single Output

Revision history

Revision history

Document version	Date of release	Description of changes
	11/19/2002	Datasheet (PD-94585)
Rev A	11/21/2002	Updated Case outline
Rev B	09/07/2006	Updated based on ECO-20772
Rev C	05/05/2022	Updated based on ECO-30588

Need Information?