



General Description

AFC5604, N & P Pair enhancement mode MOSFET, uses Advanced Trench Technology to provide excellent $R_{DS(ON)}$, low gate charge. These devices are particularly suited for low voltage power management, and low in-line power loss are needed in commercial industrial surface mount applications.

Features

N-Channel

- 40V/15A, $R_{DS(ON)} = 20m\Omega @ V_{GS} = 10V$
- 40V/12A, $R_{DS(ON)} = 30m\Omega @ V_{GS} = 4.5V$

P-Channel

- -40V/-15A, $R_{DS(ON)} = 38m\Omega @ V_{GS} = -10V$
- -40V/-12A, $R_{DS(ON)} = 54m\Omega @ V_{GS} = -4.5V$

Pin Description (TO-252-4L)

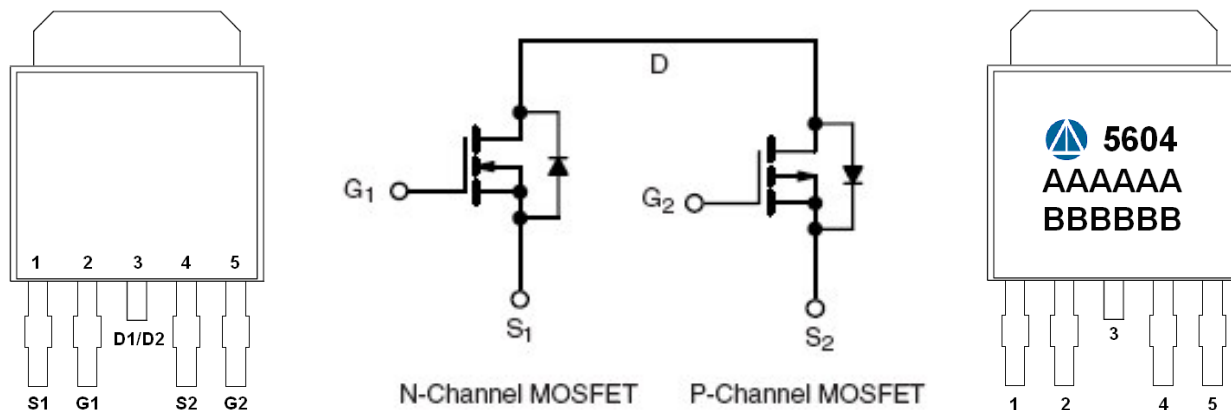

Application

- DC/DC Conversion
- Load Switch
- DC FAN

Pin Define

Pin	Symbol	Description
1	S1	Source 1
2	G1	Gate 1
3	D1 / D2	Drain 1 / Drain 2
4	S2	Source 2
5	G2	Gate 2

Ordering Information

Part Ordering No.	Part Marking	Package	Unit	Quantity
AFC5604T254RG	5604	TO-252-4L	Tape & Reel	2500 EA

※ A Lot code

※ B Date code

※ AFC5604T254RG : 13" Tape & Reel ; Pb- Free ; Halogen- Free



Absolute Maximum Ratings (N-Channel)

(T_A=25°C Unless otherwise noted)

Parameter	Symbol	Typical	Unit
Drain-Source Voltage	V _{DSS}	40	V
Gate –Source Voltage	V _{GSS}	±20	V
Continuous Drain Current(T _J =150°C)	I _D	T _A =25°C	8.0
		T _A =70°C	6.0
Pulsed Drain Current	I _{DM}	20	A
Continuous Source Current(Diode Conduction)	I _S	1.5	A
Power Dissipation	P _D	T _A =25°C	2.8
		T _A =70°C	1.8
Operating Junction Temperature	T _J	150	°C
Storage Temperature Range	T _{STG}	-55/150	°C
Thermal Resistance-Junction to Ambient	R _{θJA}	62.5	°C/W

Electrical Characteristics (N-Channel)

(T_A=25°C Unless otherwise noted)

Parameter	Symbol	Conditions	Min.	Typ	Max.	Unit
Static						
Drain-Source Breakdown Voltage	V _{(BR)DSS}	V _{GS} =0V, I _D =250uA	40			V
Gate Threshold Voltage	V _{GS(th)}	V _{DS} =V _{GS} , I _D =250uA	1.0		3.0	
Gate Leakage Current	I _{GSS}	V _{DS} =0V, V _{GS} =±20V			±100	nA
Zero Gate Voltage Drain Current	I _{DSS}	V _{DS} =32V, V _{GS} =0V			1	uA
		V _{DS} =32V, V _{GS} =0V T _J =85°C			10	
On-State Drain Current	I _{D(on)}	V _{DS} ≥ 5V, V _{GS} =10V	20			A
Drain-Source On-Resistance	R _{DS(on)}	V _{GS} =10V, I _D =15A		13	20	mΩ
		V _{GS} =4.5V, I _D =12A		18	30	
Forward Transconductance	g _{FS}	V _{DS} =15V, I _D =5.0A		25		S
Diode Forward Voltage	V _{SD}	I _S =2A, V _{GS} =0V		0.85	1.2	V
Dynamic						
Total Gate Charge	Q _g	V _{DS} =20V, V _{GS} =4.5V I _D = 5A		10	14	nC
Gate-Source Charge	Q _{gs}			2.8		
Gate-Drain Charge	Q _{gd}			3.2		
Input Capacitance	C _{iss}	V _{DS} =20V, V _{GS} =0V f=1MHz		850		pF
Output Capacitance	C _{oss}			110		
Reverse Transfer Capacitance	C _{rss}			75		
Turn-On Time	t _{d(on)}	V _{DD} =20V, R _L =4Ω I _D ≅5.0A, V _{GEN} =10V R _G =1Ω		6	12	ns
	t _r			10	20	
Turn-Off Time	t _{d(off)}			20	36	
	t _f			6	12	



Absolute Maximum Ratings (P-Channel)

(T_A=25°C Unless otherwise noted)

Parameter	Symbol	Typical	Unit
Drain-Source Voltage	V _{DSS}	-40	V
Gate –Source Voltage	V _{GSS}	±20	V
Continuous Drain Current(T _J =150°C)	I _D	T _A =25°C	-7.0
		T _A =70°C	-6.0
Pulsed Drain Current	I _{DM}	-30	A
Continuous Source Current(Diode Conduction)	I _S	-1.7	A
Power Dissipation	P _D	T _A =25°C	2.8
		T _A =70°C	1.8
Operating Junction Temperature	T _J	150	°C
Storage Temperature Range	T _{STG}	-55/150	°C
Thermal Resistance-Junction to Ambient	R _{θJA}	62.5	°C/W

Electrical Characteristics (P-Channel)

(T_A=25°C Unless otherwise noted)

Parameter	Symbol	Conditions	Min.	Typ	Max.	Unit
Static						
Drain-Source Breakdown Voltage	V _{(BR)DSS}	V _{GS} =0V, I _D = -250uA	-40			V
Gate Threshold Voltage	V _{G(th)}	V _{DS} =V _{GS} , I _D = -250uA	-1.0		-3.0	
Gate Leakage Current	I _{GSS}	V _{DS} =0V, V _{GS} = ±20V			±100	nA
Zero Gate Voltage Drain Current	I _{DSS}	V _{DS} = -32V, V _{GS} =0V			-1	uA
		V _{DS} = -32V, V _{GS} =0V T _J =85°C			-20	
On-State Drain Current	I _{D(on)}	V _{DS} ≥ -5V, V _{GS} = -10V	-20			A
Drain-Source On-Resistance	R _{DS(on)}	V _{GS} = -10V, I _D =-15A		30	38	mΩ
		V _{GS} = -4.5V, I _D =-12A		44	54	
Forward Transconductance	g _{FS}	V _{DS} = -15V, I _D = -5A		20		S
Diode Forward Voltage	V _{SD}	I _S = -2A, V _{GS} =0V		-0.8	-1.2	V
Dynamic						
Total Gate Charge	Q _g	V _{DS} =-20V, V _{GS} =-4.5V I _D = -5.0A		13	20	nC
Gate-Source Charge	Q _{gs}			4.5		
Gate-Drain Charge	Q _{gd}			6.5		
Input Capacitance	C _{iss}	V _{DS} =-20V, V _{GS} =0V f=1MHz		1100		pF
Output Capacitance	C _{oss}			145		
Reverse Transfer Capacitance	C _{rss}			115		
Turn-On Time	t _{d(on)}	V _{DD} =-20V, R _L =4Ω I _D ≡ -5.0A, V _{GEN} =-4.5V R _G =1Ω		40	80	ns
	t _r			55	100	
Turn-Off Time	t _{d(off)}			30	60	
	t _f			12	20	



Typical Characteristics (N-Channel)

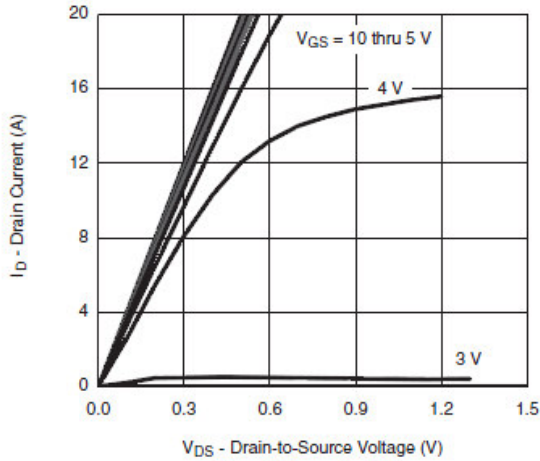

Output Characteristics

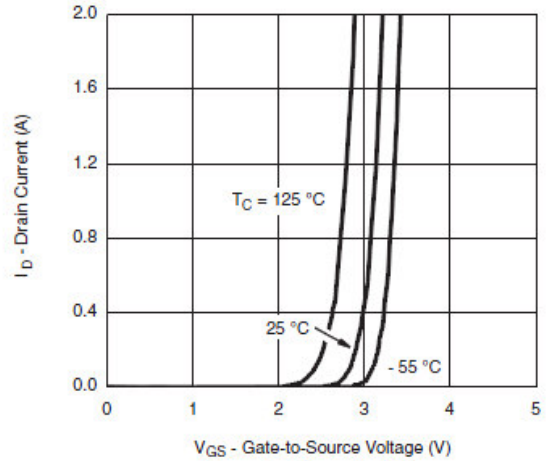

Transfer Characteristics

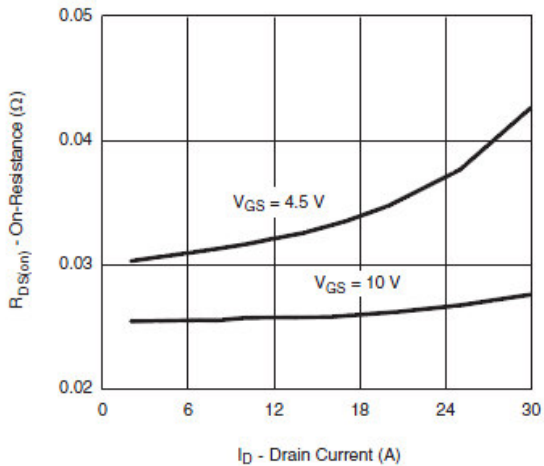

On-Resistance vs. Drain Current and Gate Voltage

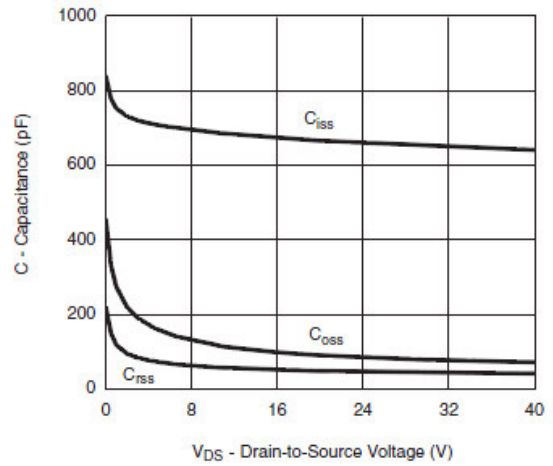

Capacitance

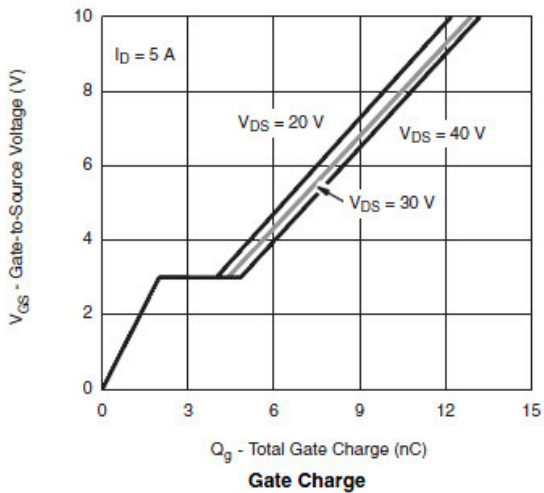

Gate Charge

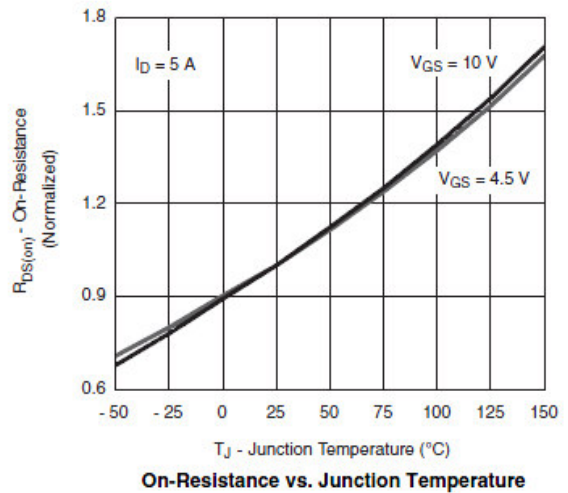

On-Resistance vs. Junction Temperature



Typical Characteristics (N-Channel)

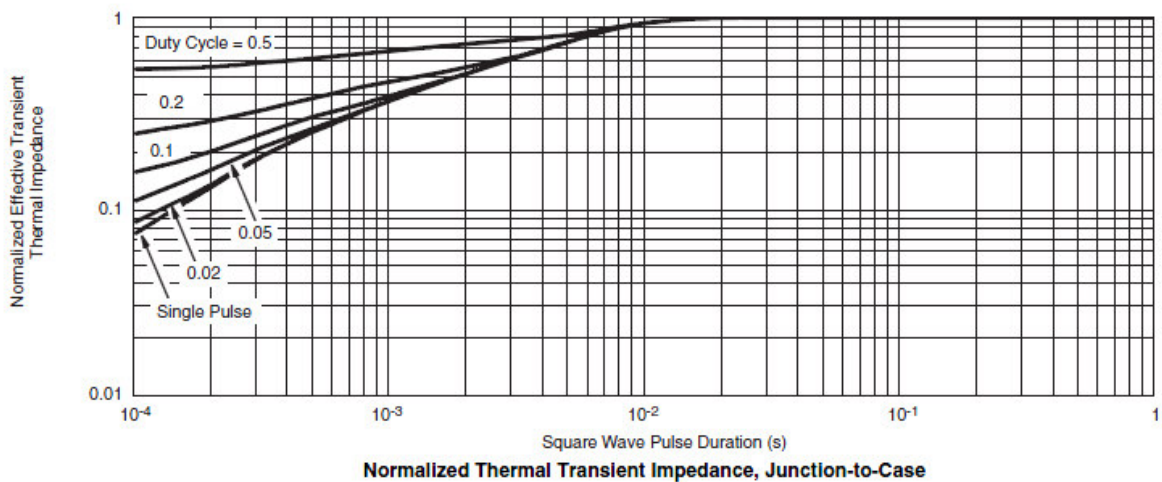
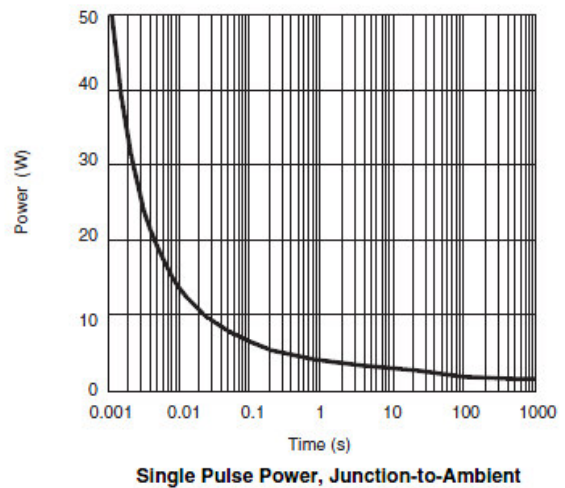
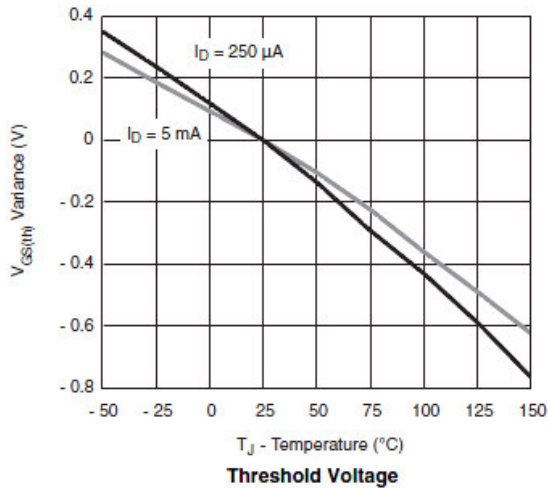
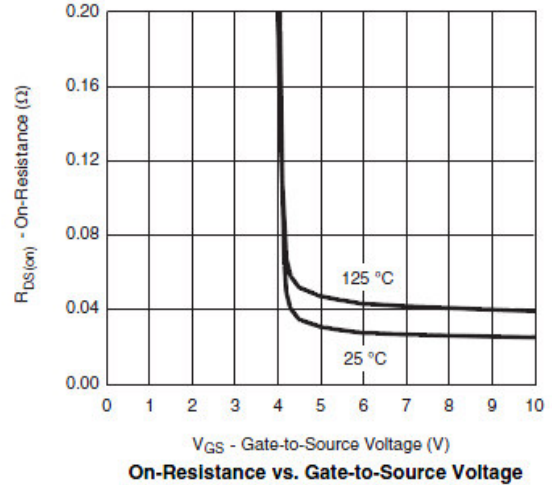
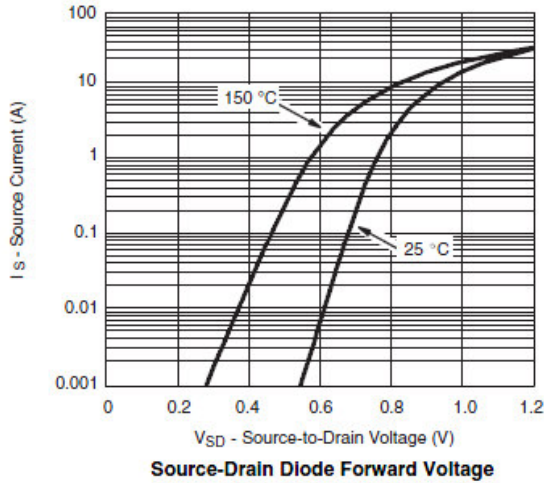



Typical Characteristics (P-Channel)

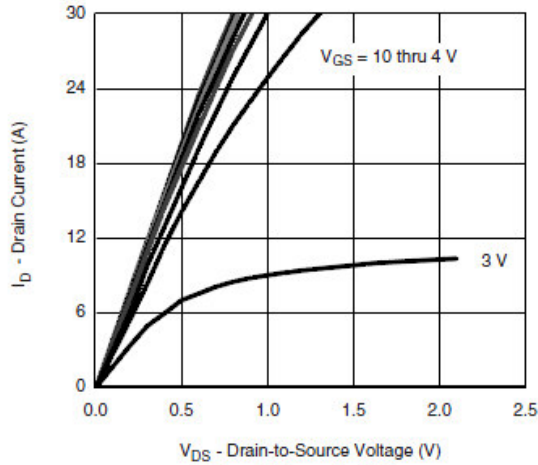

Output Characteristics

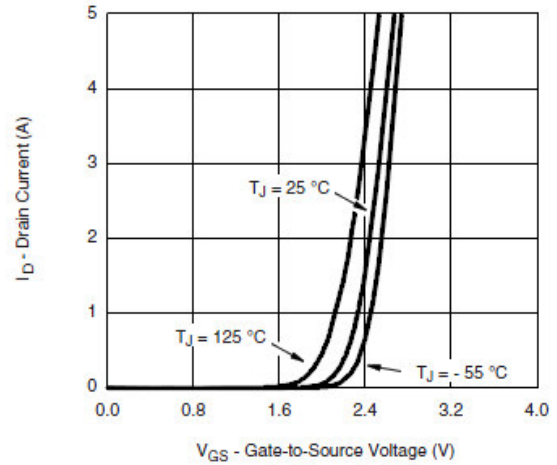

Transfer Characteristics

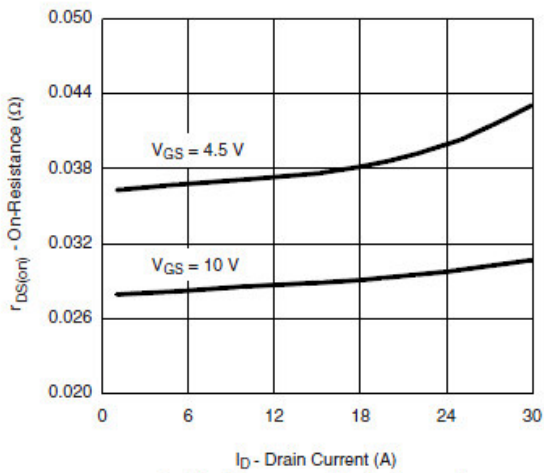

On-Resistance vs. Drain Current

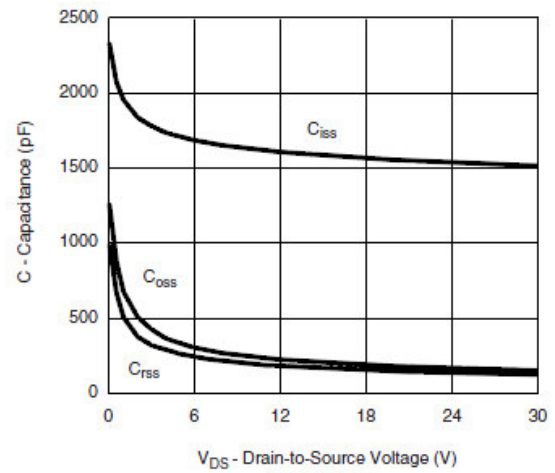

Capacitance

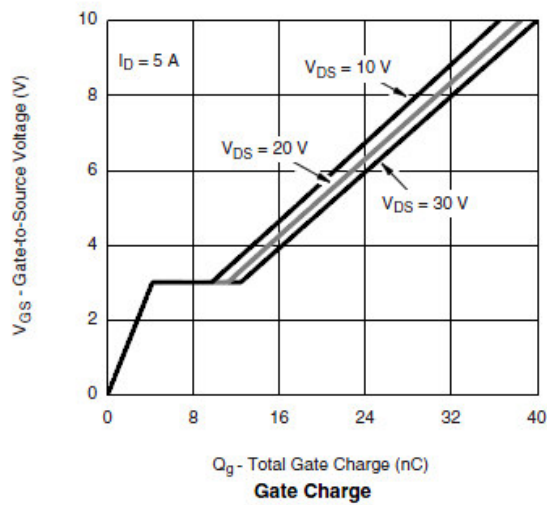

Gate Charge

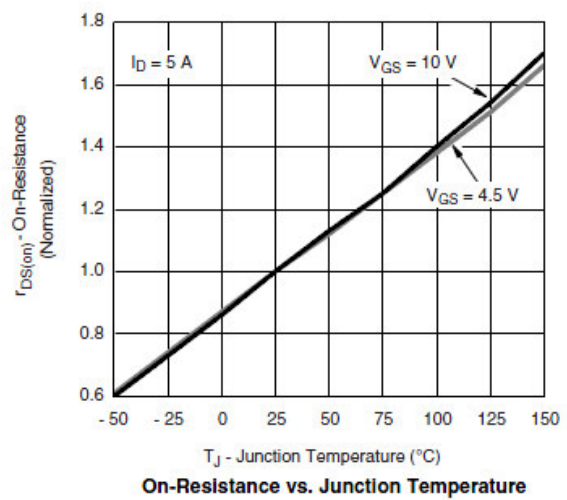

On-Resistance vs. Junction Temperature



Typical Characteristics (P-Channel)

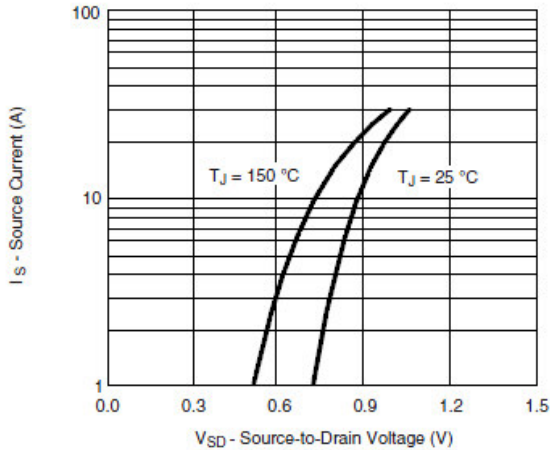

Source-Drain Diode Forward Voltage

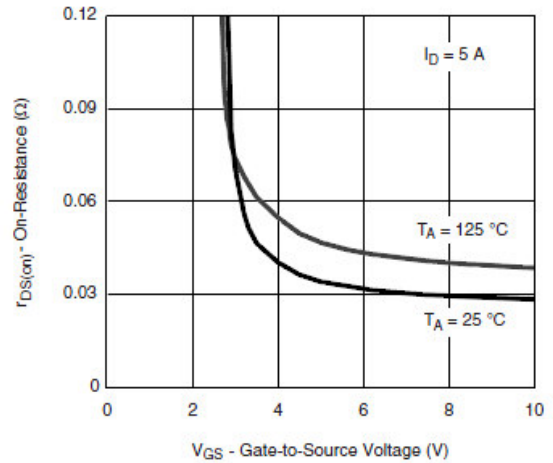

On-Resistance vs. Gate-to-Source Voltage

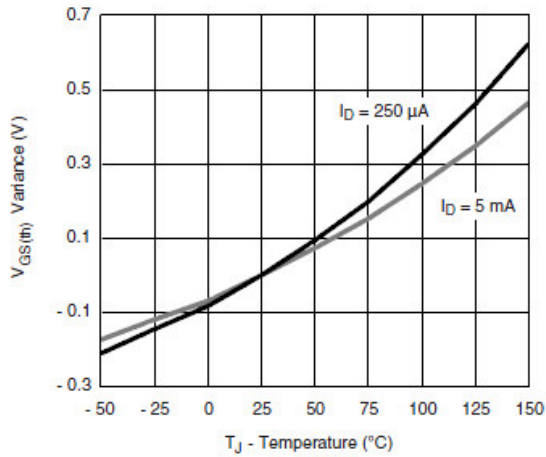

Threshold Voltage

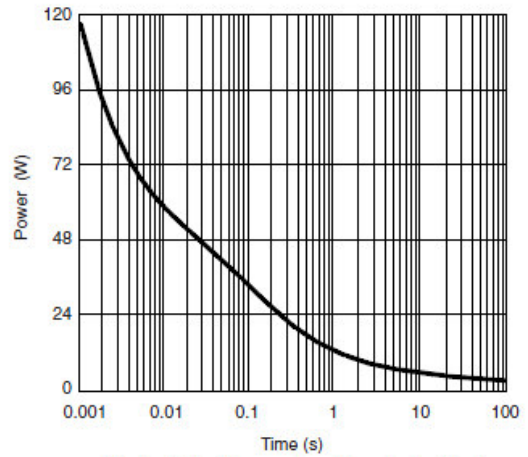

Single Pulse Power, Junction-to-Ambient

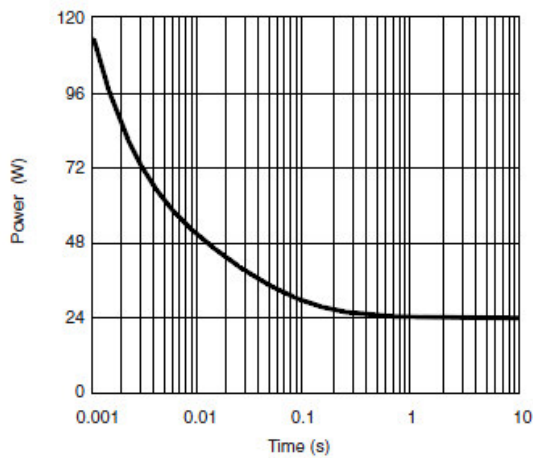

Single Pulse Power, Junction-to-Case

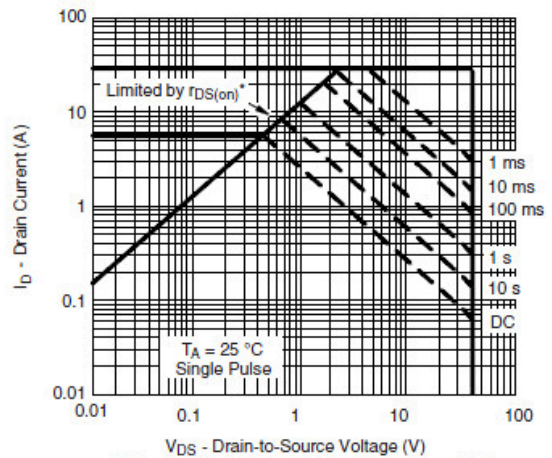

Safe Operating Area, Junction-to-Ambient



Typical Characteristics

Gate Charge Test Circuit & Waveform

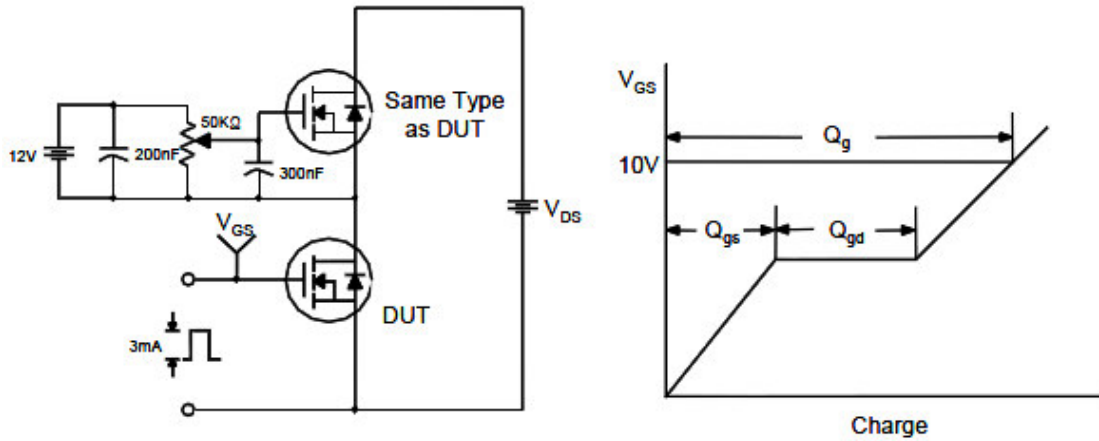

Resistive Switching Test Circuit & Waveforms

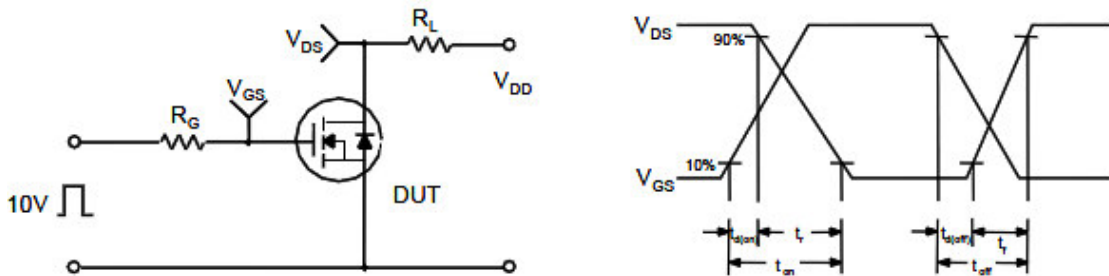

Unclamped Inductive Switching Test Circuit & Waveforms

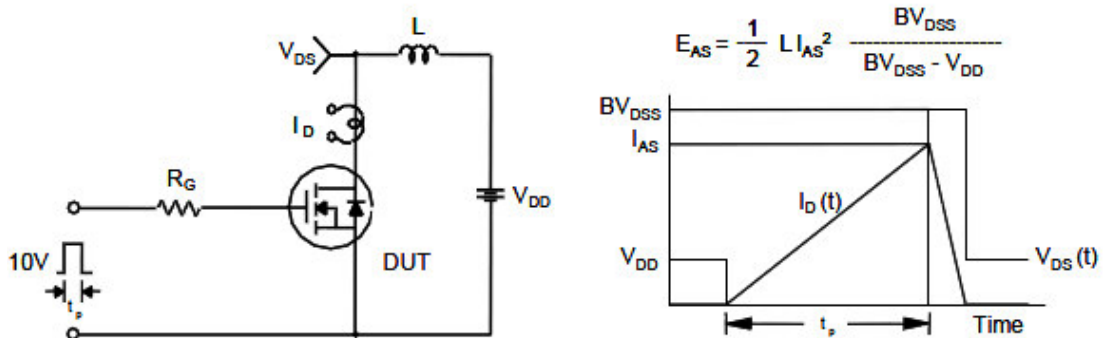



Package Information (TO-252-4L)

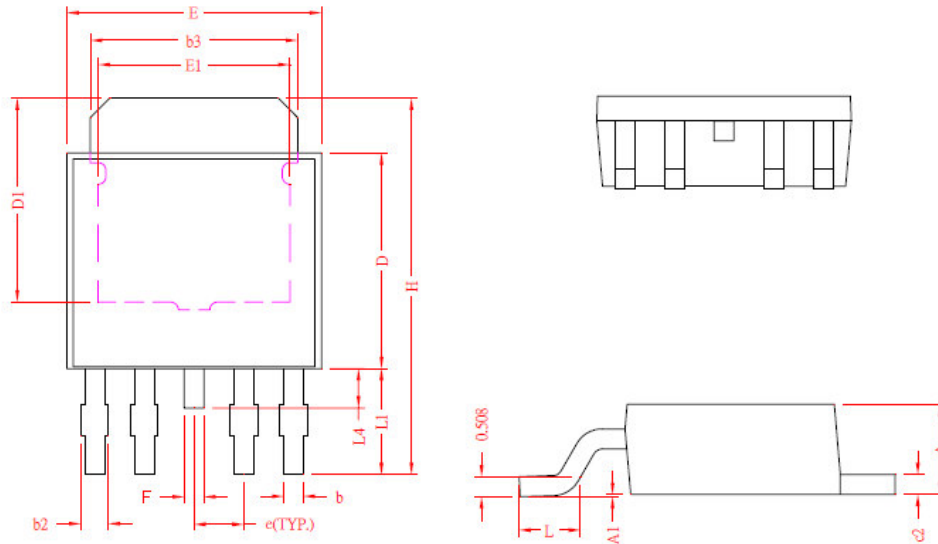

REF.	Millimeter		REF.	Millimeter	
	Min.	Max.		Min.	Max.
A	2.20	2.40	E	6.40	6.80
A1	0	0.15	E1	3.81	---
b	0.40	0.60	e	1.27 REF.	
b2	0.50	0.80	F	0.40	0.60
b3	5.20	5.50	H	9.40	10.20
c2	0.45	0.55	L	1.40	1.77
D	5.40	5.80	L1	2.40	3.00
D1	4.57	---	L4	0.80	1.20

©2010 Alfa-MOS Technology Corp.
 2F, No.80, Sec.1, Cheng Kung Rd., Nan Kang Dist., Taipei City 115, Taiwan (R.O.C.)
 Tel : 886 2) 2651 3928
 Fax : 886 2) 2786 8483
 ©http://www.alfa-mos.com