



Your Total LCD Solution Provider

<http://www.orientdisplay.com>

SPECIFICATION FOR LCD MODULE

**MODULE NO : AFE1024600I-10.1N-9296A-N
REVISION NO: 01**

Customer's Approval:

--

	SIGNATURE	DATE
PREPARED BY (RD ENGINEER)		
CHECKED BY		
APPROVED BY		

Record of Revision

Version	Revise Date	Page	Content
0.0	2009/10/22	All	First edition issued
0.1	2010/01/18	11	Timing table: Clock freq. 58.6MHz (Typ.)→57.5MHz Line cycle time 1507tclk (Typ.)→1478tclk
		12	LED power consumption: 1.38W (Typ.)→1.81W 1.58W (Max.)→1.92W
		13	Color chromaticity: Rx 0.580, Ry 0.340 Gx 0.310, Gy 0.550 Bx 0.155, By 0.155
		20	Packing Form update
		23	EDID code: X20 Checksum: B3

Contents:	Page
1. General Specifications	2
2. Electrical Specifications	
2-1 Pin Assignment	3
2-2 Absolute Maximum Ratings	5
2-3 Electrical Characteristics	6
3. Optical Specifications	12
4. Reliability Test Items	15
5. Safety	16
6. Display Quality	16
7. Handling Precaution	16
8. Label Definition	17
9. Packing Form	19
10. Mechanical Drawings	21
Appendix	23

1. General Specifications

No.	Item	Specification	Unit
1	Display resolution (pixel)	1024 (H) x 600 (V), WSVGA resolution	
2	Active area	222.72 (H) x 125.28 (V)	mm
3	Screen size	10.1 inches diagonal	Inches
4	Pixel pitch	217.5 (H) x 208.8 (V)	um
5	Color configuration	R, G, B vertical stripe	
6	Overall dimension	249.3 (H) x 147(V) x 3.6 (D) (max)	mm
7	Weight	180 Max.	Grams
8	Surface treatment	Anti-glare	
9	Input color signal	6 bit LVDS	
10	Display colors	262K (6 bit)	
11	Optimum viewing direction	6 o'clock	
12	Backlight	W-LED	
13	RoHS	RoHS compliance	

2. Electrical Specifications

2-1 Pin Assignment

a. Panel connector

Connector Part No.: 20455-040-12 (I-PEX) or equivalent

User's connector Part No: 20453-040T-12 (I-PEX) or equivalent

PIN NO	Symbol	Function	Remark
1	NC	No connection (Reserve)	
2	V _{CC}	Power Supply (+3.3V)	
3	V _{CC}	Power Supply (+3.3V)	
4	V _{EDID}	DDC Power +3.3V	
5	NC	No connection (Reserve)	
6	Clk _{EDID}	DDC Clock	
7	DATA _{EDID}	DDC Data	
8	Rxin0-	Differential data input	R0~R5,G0
9	Rxin0+	Differential data input	
10	GND	Ground	
11	Rxin1-	Differential data input	G1~G5,B0,B1
12	Rxin1+	Differential data input	
13	GND	Ground	
14	Rxin2-	Differential data input	B2~B5,DE,Hsync,Vsync
15	Rxin2+	Differential data input	
16	GND	Ground	
17	CLK-	Differential clock input	
18	CLK+	Differential clock input	
19	NC	No connection (Reserve)	
20	NC	No connection (Reserve)	
21	NC	No connection (Reserve)	
22	NC	No connection (Reserve)	
23	NC	No connection (Reserve)	
24	NC	No connection (Reserve)	
25	NC	No connection (Reserve)	
26	NC	No connection (Reserve)	
27	NC	No connection (Reserve)	
28	NC	No connection (Reserve)	
29	NC	No connection (Reserve)	
30	NC	No connection (Reserve)	
31	LED_GND	LED Ground	
32	LED_GND	LED Ground	
33	LED_GND	LED Ground	
34	NC	No connection (Reserve)	
35	LED_PWM	PWM dimming signal input	
36	LED_EN	LED enable pin (3.3V)	
37	NC	No connection (Reserve)	
38	V_LED	LED power supply 7.5V~21V	
39	V_LED	LED power supply 7.5V~21V	
40	V_LED	LED power supply 7.5V~21V	

b. General Block Diagram

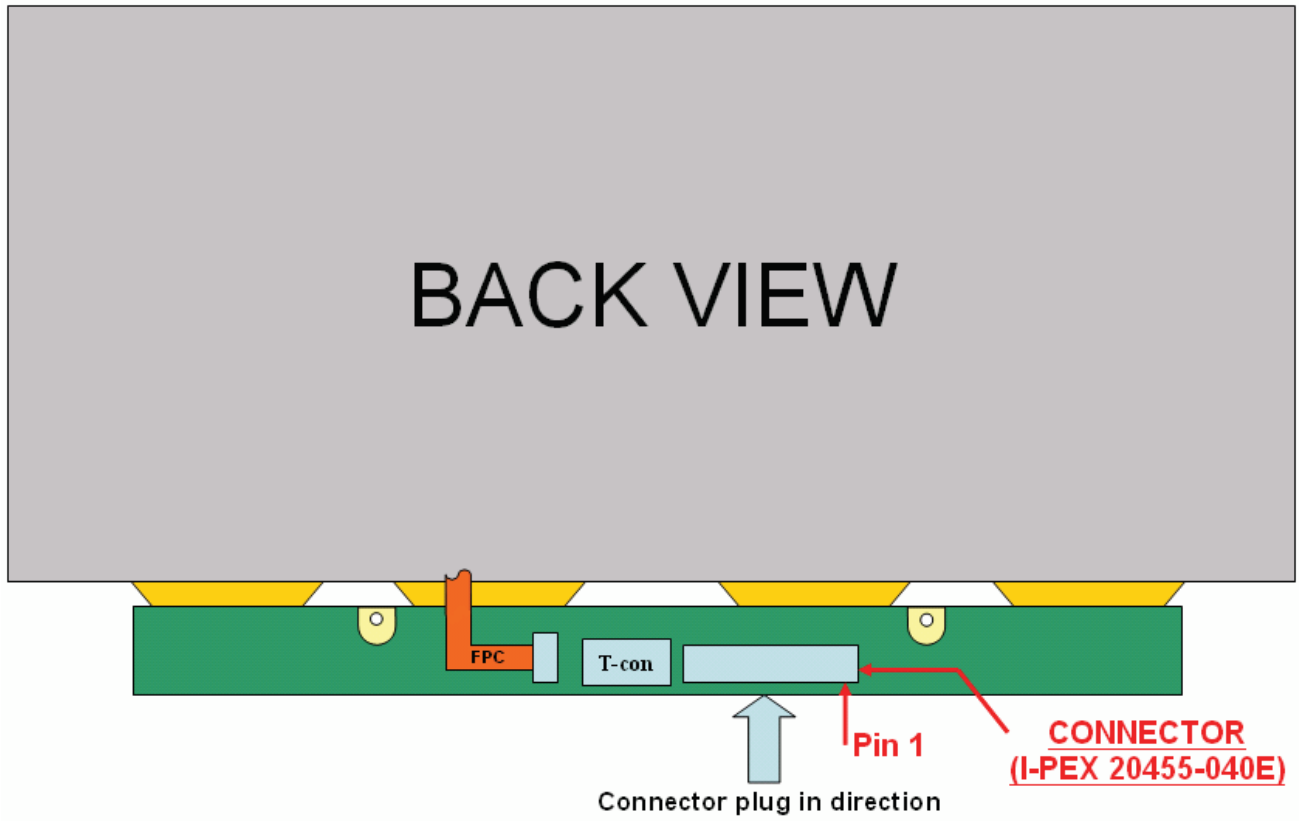

2-2. Absolute Maximum Ratings

Parameter	Symbol	Values		Unit	Remark
		Min.	Max.		
Power input voltage	V_{CC}	- 0.3	4.0	V	At 25°C
Input signal voltage	V_{IN}	- 0.3	4.0	V	At 25°C
LED input voltage	V_{LED}	- 0.3	30	V	
Operating temperature	T_{OP}	0	50	°C	Note 1
Storage temperature	T_{ST}	- 20	60	°C	Note 2
Re-screw		-	5	Times	
Assured torque at side mount		-	2	kgf.cm	

Note 1: The relative humidity must not exceed 90%, non-condensing at temperatures of 40°C or less. At temperatures greater than 40°C, the wet bulb temperature must not exceed 39°C.

Note 2: The unit should not be exposed to corrosive chemicals.

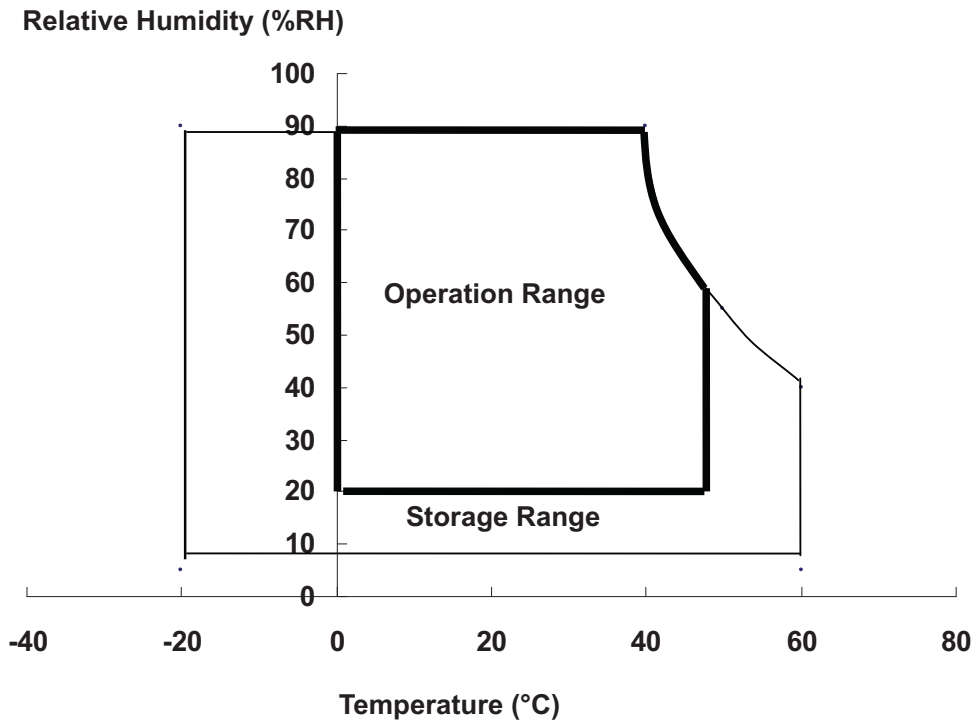

2-3. Electrical Characteristics

a. Typical operating conditions

Item	Symbol	Min.	Typ.	Max.	Unit	Remark	
Power input voltage	V_{CC}	3	3.3	3.6	V		
Permissive power input ripple	V_{RF}			0.1	V		
Power input current	I_{CC}		220	250	mA	Note 1	
Power consumption	P_c		0.73	0.83	Watts	Note 1	
LVDS interface	Differential input high threshold voltage	V_{LVTH}		+100	mV	$V_{LVC}=1.2V$, Note 2	
	Differential input low threshold voltage	V_{LVTL}	-100		mV	$V_{LVC}=1.2V$, Note 2	
	Common input voltage	V_{LVC}	1.0	1.2	1.4	V	Note 2
	Terminating resistor	R_T	90	100	110	ohm	
Rush current	I_{Rush}	-	-	1	A	Note 3	
LED rush current	$I_{LED-Rush}$	-	-	1.5	A	Note 4	

Note 1: The specified input current and power consumption are under the $V_{CC}=3.3$ V, 25 °C, $f_v=60$ Hz (frame frequency) condition whereas black pattern is displayed.

Note 2: LVDS waveform diagram

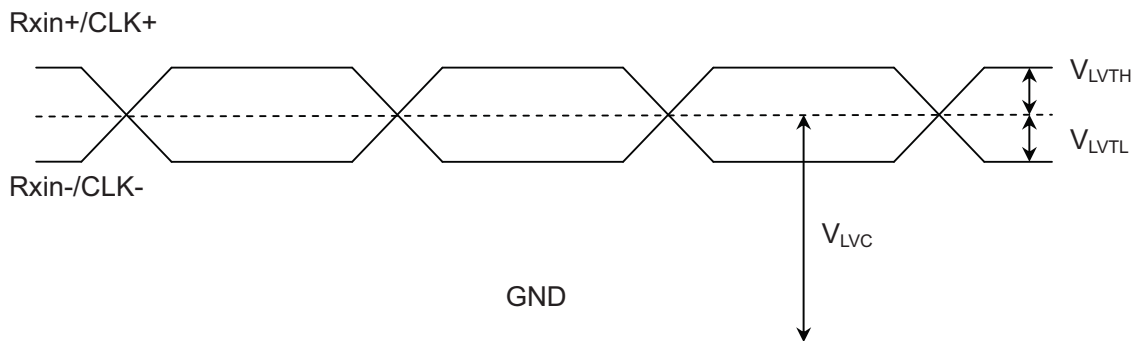

Note 3: Test condition

- (1) Pattern: Black pattern
- (2) $V_{CC} = 3.3\text{ V}$, V_{CC} rising time = $470\ \mu\text{s} \pm 10\%$

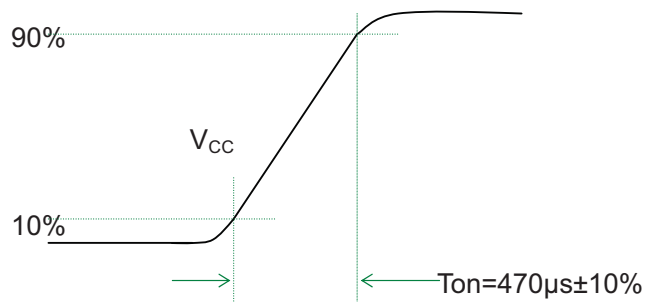

(3) Test circuit

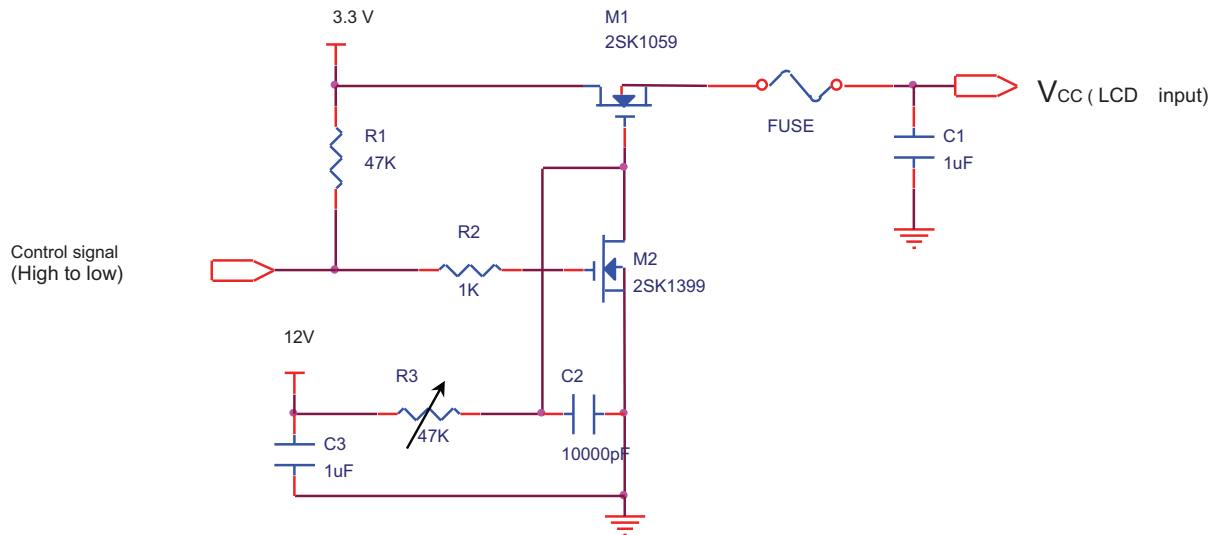

Note 4: Test condition

(1) LED duty 100%

(2) $V_{LED} = 12.0V$, V_{LED} rising time = $470 \mu s \pm 10\%$

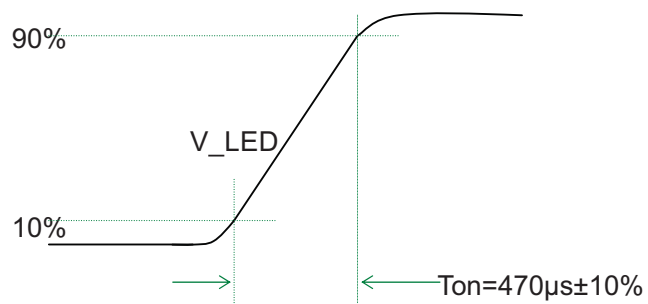

(3) Test circuit

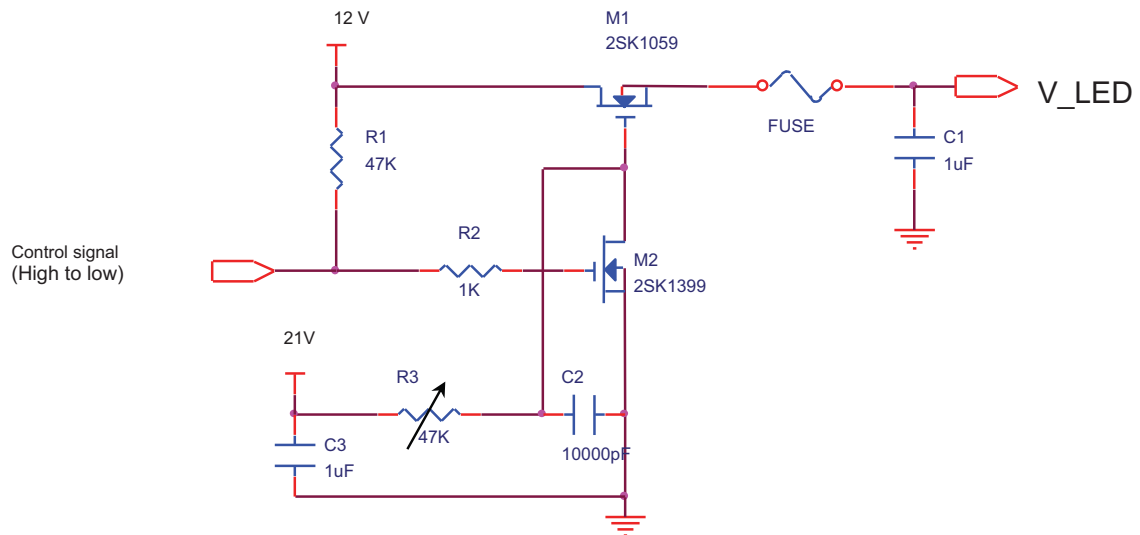

b. Power sequence

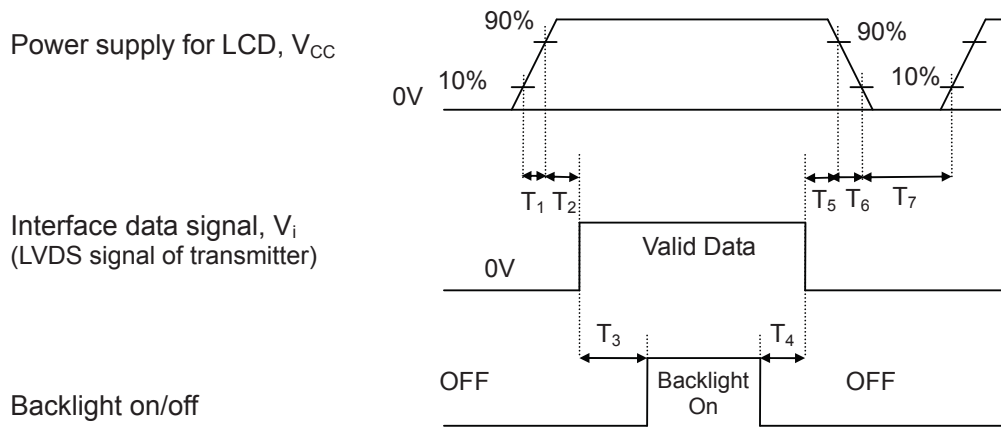

Power sequence timing table

Parameter	Value			Units
	Min.	Typ.	Max.	
T_1	0.5	-	10	ms
T_2	0	-	50	ms
T_3	200	-	-	ms
T_4	200	-	-	ms
T_5	0	-	50	ms
T_6	0	-	10	ms
T_7	400	-	-	ms

c. Display color vs. input data signals

Signal Name	Description	Remark
R5	Red Data 5 (MSB)	Red-pixel data. Each red pixel's brightness data consists of these 6 bits pixel data.
R4	Red Data 4	
R3	Red Data 3	
R2	Red Data 2	
R1	Red Data 1	
R0	Red Data 0 (LSB)	
	Red-pixel Data	
G5	Green Data 5 (MSB)	Green-pixel data. Each green pixel's brightness data consists of these 6 bits pixel data.
G4	Green Data 4	
G3	Green Data 3	
G2	Green Data 2	
G1	Green Data 1	
G0	Green Data 0 (LSB)	
	Green-pixel Data	
B5	Blue Data 5 (MSB)	Blue-pixel data. Each blue pixel's brightness data consists of these 6 bits pixel data.
B4	Blue Data 4	
B3	Blue Data 3	
B2	Blue Data 2	
B1	Blue Data 1	
B0	Blue Data 0 (LSB)	
	Blue-pixel Data	

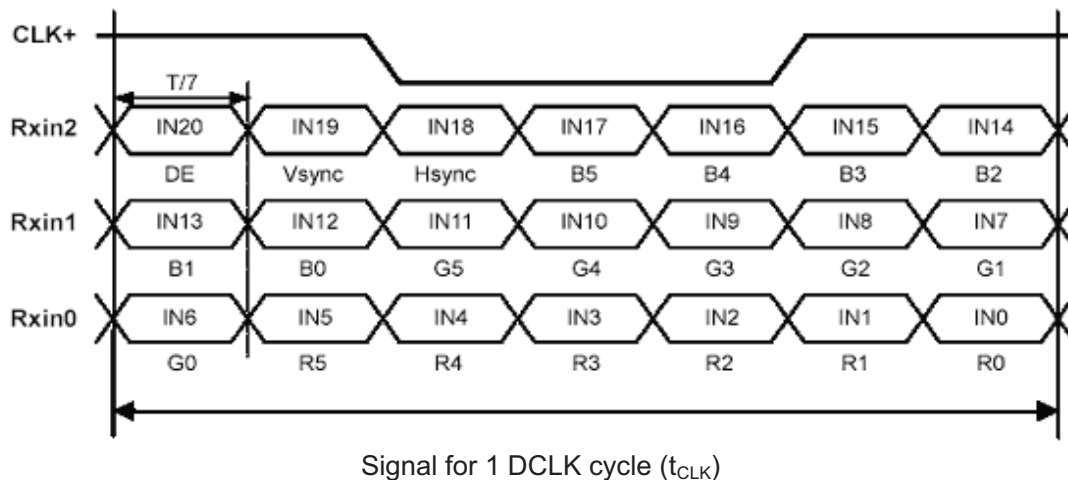

d. Input signal timing

Timing table

Description	Symbol	Min	Typ	Max	Unit
Frame rate	--	--	60	--	Hz
Clock freq.	$1/t_{CLK}$	(40)	57.5	(59)	MHz
Line cycle time	t_H	(1054)	1478	(1400)	t_{CLK}
Line width-active	t_{Hd}	--	1024	--	t_{CLK}
Frame cycle time	t_V	(610)	648	(654)	t_H
V width-active	t_{Vd}	--	600	--	t_H

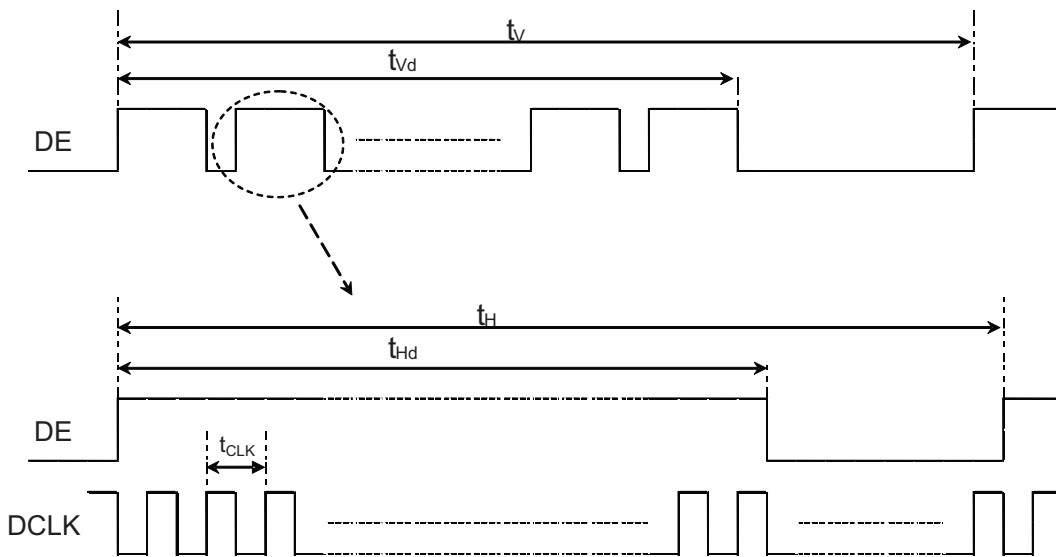

e. Display position

D(1, 1)	D(2, 1)	D(673, 1)	D(1023, 1)	D(1024, 1)
D(1, 2)	D(2, 2)	D(673, 2)	D(1023, 2)	D(1024, 2)
⋮		⋮	⋮	⋮
D(1, 384)	D(2, 300)	D(673, 384)	D(1023, 300)	D(1024, 300)
⋮		⋮	⋮	⋮
D(1, 767)	D(2, 599)	D(673, 599)	D(1023, 599)	D(1024, 599)
D(1, 768)	D(2, 600)	D(673, 600)	D(1023, 600)	D(1024, 600)

f. Backlight driving conditions

Parameter	Symbol	Min.	Typ.	Max.	Unit	Remark
LED forward voltage	V_F	3	3.2	3.4	V_{rms}	T = 25°C
LED forward current	I_F		20		mA_{rms}	T = 25°C
LED power consumption	P_{LED}		1.81	1.92	W	T = 25°C
Output PWM frequency	F_{PWM}	200		2000	Hz	T = 25°C
Duty ratio	-	5		100	%	Note 1
LED life time (LED only)	-	15,000			Hr	T = 25°C , Note 2

Note 1: PWM duty ratio linearity guarantees 20~100%

Note 2: LED life time definition is Brightness decrease to 50% of initial or abnormal lighting.

g. Module function block

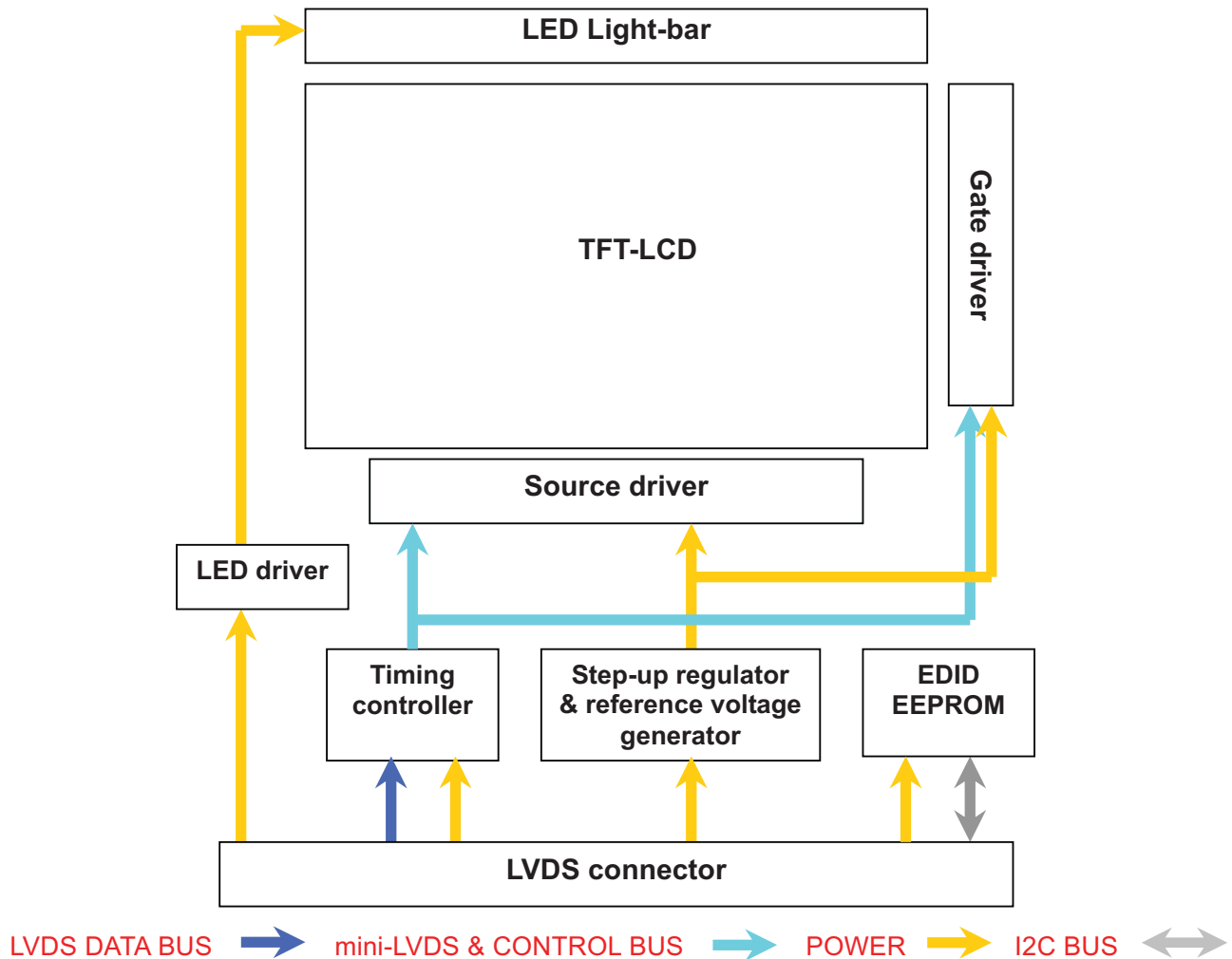

3. Optical specifications

Ambient temperature = 25°C

Item	Symbol	Condition	Specification			Unit	Remark
			Min.	Typ.	Max.		
Response time	Tr+Tf	$\theta = 0^\circ$		8	16	ms	Note 3
Contrast ratio	CR	$\theta = 0^\circ$	400	500			Note 2,4
Viewing angle	Top	$CR \geq 10$	15			deg	Note 2,4,6
	Bottom		30				
	Left		40				
	Right		40				
Brightness (5 points average)	Y_L		170	200		nit	Note 2,5
Color chromaticity (CIE)	W_x	$\theta = 0^\circ$	-0.03	0.313	+0.03		Note 2
	W_y			0.329			
	R_x			0.580			
	R_y			0.340			
	G_x			0.310			
	G_y			0.550			
	B_x			0.155			
	B_y			0.155			
Color Gamut	NTSC	CIE1931	40	45		%	-
White uniformity	$\delta_{W(5)}$		0.8				Note 2,7
	$\delta_{W(13)}$		0.65				
Cross talk	Ct				2%		Note 8

Note 1: To be measured in dark room.

Note 2: To be measured with a viewing cone of 2° by Topcon luminance meter BM-5A.

Note 3: Definition of response time:

The output signals of BM-7 are measured when the input signals are changed from “Black” to “White” (falling time) and from “White” to “Black” (rising time), respectively. The response time interval is between 10% and 90% of amplitudes. Refer to figure as below.

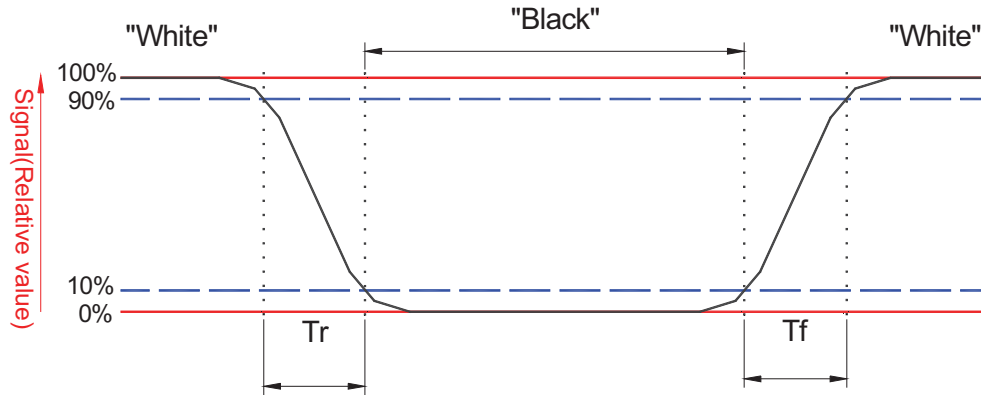

Note 4: Definition of contrast ratio:

Contrast ratio is calculated with the following formula:

$$\text{Contrast ratio (Avg of 5pts)} = \frac{L_{\text{white (Avg of 5pts.)}}}{L_{\text{Black (Avg of 5pts.)}}}$$

Note 5: Driving current for LED should be 20 mA.

Luminance are measured at the following thirteen points (1~13):

$$Y_L = (Y_5 + Y_{10} + Y_{11} + Y_{12} + Y_{13}) / 5$$

Note 6: Definition of viewing angle

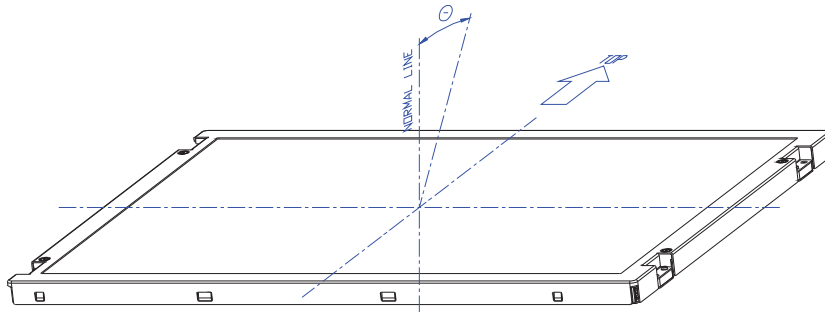

Note 7: Definition white uniformity:

Luminance is measured at the following thirteen points (1~13):

$$\delta_{W(13)} = \frac{\text{Minimum Brightness of thirteen points}}{\text{Maximum Brightness of thirteen points}}$$

$$\delta_{W(5)} = \frac{\text{Minimum Brightness of five points}}{\text{Maximum Brightness of five points}}$$

13 point measuring locations refer to the point 1, 2, 3, 4, 5, 6, 7, 8, 9, 10, 11, 12 and 13.
 5 point measuring locations refer to the point 3, 5, 7, 11 and 12.

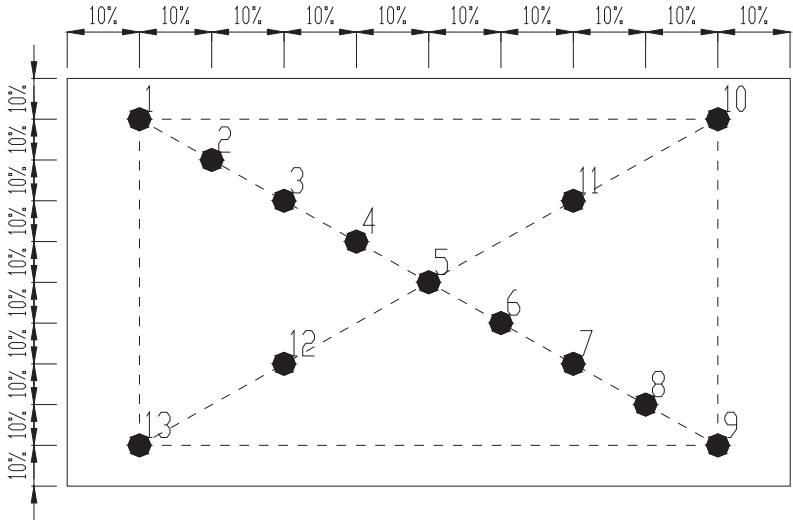

Note 8:

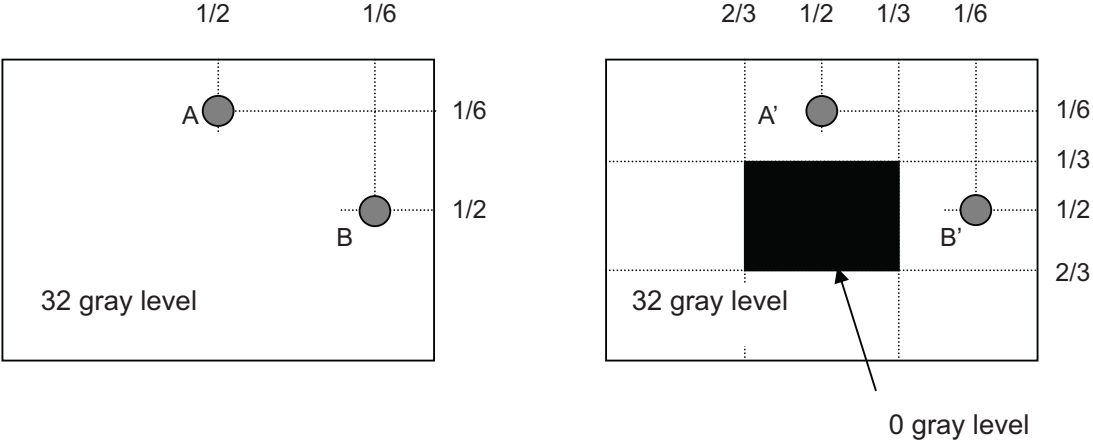

Unit: percentage of dimension of display area
 $|L_A - L_{A'}| / L_A \times 100\% = 2\% \text{ max.}$, L_A and $L_{A'}$ are brightness at location A and A'
 $|L_B - L_{B'}| / L_B \times 100\% = 2\% \text{ max.}$, $L_{B'}$ and L_B are brightness at location B and B'

4. Reliability test items

Test Item	Test Condition	Judgment	Remark
High temperature storage	60°C, 240 hours	Note 1	Note 2
Low temperature storage	-20°C, 240 hours	Note 1	Note 2
High temperature & high humidity operation	40°C, 90% RH, 240 hours (No condensation)	Note 1	Note 2
High temperature operation	50°C, 240 hours	Note 1	Note 2
Low temperature operation	0°C, 240 hours	Note 1	Note 2
Thermal Shock (Non-operation)	-25°C / 30 mins ~ 65°C / 30 mins 100 cycles	Note 1	Note 2
Electrostatic discharge (ESD)	150 pF, 330Ω, Contact: ±8kV, Air: ±15kV	Note 1	
Vibration (Non-operation)	1.5Grms, (PSD: 0.0046 [^] G/Hz) 10 to 500 Hz random; 0.5hr for each perpendicular	Note 1	Note 2
Mechanical shock (Non-operation)	220G/2ms, Half sine wave, ±X, ±Y, ±Z one time for each direction	Note 1	Note 2

Note 1: Pass: Normal display image with no obvious non-uniformity and no line defect.
 Fail: No display image, obvious non-uniformity, or line defects.
 Partial transformation of the module parts should be ignored.

Note 2: Evaluation should be tested after storage at room temperature more than one hour.

5. Safety

5-1. Sharp edge requirements

There will be no sharp edges or corners on the display assembly that could cause injury.

5-2. Materials

a. Toxicity

There will be no carcinogenic materials used anywhere in the display module. If toxic materials are used, they will be reviewed and approved by the responsible InnoLux Toxicologist.

b. Flammability

All components including electrical components that do not meet the flammability grade UL94-V0 in the module will complete the flammability rating exception approval process. The printed circuit board will be made from material rated 94-V0 or better. The actual UL flammability rating will be printed on the printed circuit board.

c. Capacitors

If any polarized capacitors are used in the display assembly, provisions will be made to keep them from being inserted backwards.

6. Display quality

The display quality of the color TFT-LCD module should be in compliance with the InnoLux incoming inspection standard.

7. Handling precaution

- (1) Do not apply rough force such as bending or twisting to the module during assembly.
- (2) To assemble or install module into user's system can be only in clean working areas. The dust and oil may cause electrical short or worsen the polarizer.
- (3) It's not permitted to have pressure or impulse on the module because the LCD panel and Backlight will be damaged.
- (4) Always follow the correct power sequence when LCD module is connecting and operating.
- (5) Do not pull the I/F connector in or out while the module is operating.
- (6) Do not disassemble the module.
- (7) Use a soft dry cloth without chemicals for cleaning, because the surface of polarizer is very soft and easily scratched.
- (8) It is dangerous that moisture come into or contacted the LCD module, because moisture may damage LCD module when it is operating.
- (9) High temperature or humidity may reduce the performance of module. Please store LCD module within the specified storage conditions.

9. Packing Form

Full packing: 40pcs Module.

↓ Step A
LCM

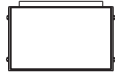

PET Tray

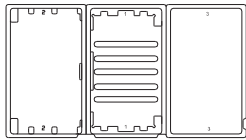

↓ Step B
Put LCM-1 into PET Tray

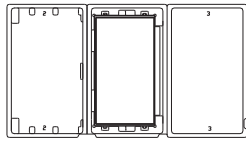

↓ Step C
Turn back PET Tray And
Put LCM-2 into PET Tray

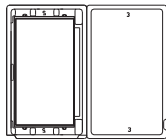

↓ Step D

Turn back the PET Tray



Step E

Put LCM with PET Tray into carton

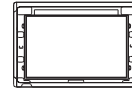

↓ Step F
upper cushion(1PCS)

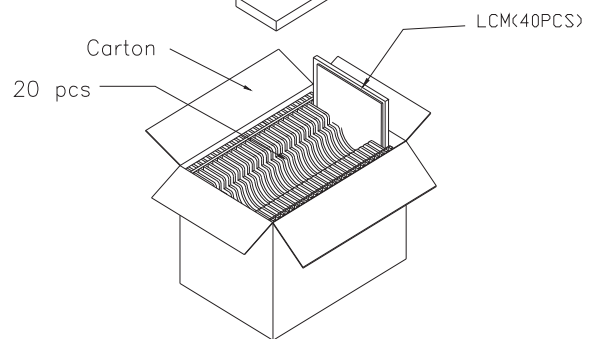
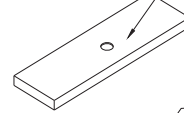

↓ Step G

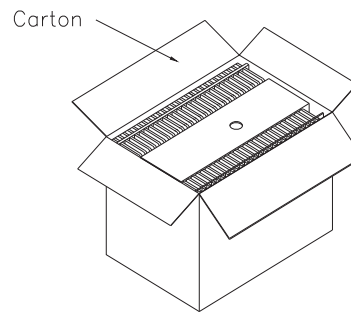

↓ Step H

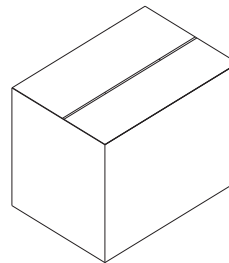

Appendix: EDID Code

	Byte	Field Name and Comments	Value	Value
	(hex)		(hex)	(binary)
Header	0	Header	00	00000000
	1	Header	FF	11111111
	2	Header	FF	11111111
	3	Header	FF	11111111
	4	Header	FF	11111111
	5	Header	FF	11111111
	6	Header	FF	11111111
	7	Header	00	00000000
Vendor / Product EDID Version	8	EISA manufacture code = 3 Character ID	25	00100101
	9	EISA manufacture code (Compressed ASCII)	CC	11001100
	0A	Panel Supplier Reserved – Product Code	0E	00001110
	0B	Panel Supplier Reserved – Product Code	00	00000000
	0C	LCD module Serial No - Preferred but Optional (“0” if not used)	00	00000000
	0D	LCD module Serial No - Preferred but Optional (“0” if not used)	00	00000000
	0E	LCD module Serial No - Preferred but Optional (“0” if not used)	00	00000000
	0F	LCD module Serial No - Preferred but Optional (“0” if not used)	00	00000000
	10	Week of manufacture	00	00000000
	11	Year of manufacture	14	00010100
	12	EDID structure version # = 1	01	00000001
	13	EDID revision # = 4	04	00000100
	Display Parameters	14	Video I/P definition = Digital I/P	90
15		Max H image size = (22.2= 22cm)	16	00010110
16		Max V image size = (12.5=12 cm)	0C	00001100
17		Display gamma = (gamma ×100)-100 = Example: (2.2×100)–100 = 120	78	01111000
18		Feature support (no DPMS, Active off, RGB, timing BLK 1)	0A	00001010
Panel Color Coordinates	19	Red/Green Low bit (RxRy/GxGy)	98	10011000
	1A	Blue/White Low bit (BxBY/WxWy)	F5	11110101
	1B	Red x Rx=0.5801	94	10010100
	1C	Red y Ry= 0.3408	57	01010111
	1D	Green x Gx= 0.3105	4F	01001111
	1E	Green y Gy= 0.5508	8D	10001101
	1F	Blue x Bx= 0.1553	27	00100111
	20	Blue y By= 0.1553	27	00100111
	21	White X Wx= 0.3135	50	01010000
	22	White Y Wy= 0.3291	54	01010100
Established Timings	23	Established timings 1 (00h if not used)	00	00000000
	24	Established timings 2 (00h if not used)	00	00000000
	25	Manufacturer’s timings (00h if not used)	00	00000000

Standard Timing ID	26	Standard timing ID1 (01h if not used)	01	00000001
	27	Standard timing ID1 (01h if not used)	01	00000001
	28	Standard timing ID2 (01h if not used)	01	00000001
	29	Standard timing ID2 (01h if not used)	01	00000001
	2A	Standard timing ID3 (01h if not used)	01	00000001
	2B	Standard timing ID3 (01h if not used)	01	00000001
	2C	Standard timing ID4 (01h if not used)	01	00000001
	2D	Standard timing ID4 (01h if not used)	01	00000001
	2E	Standard timing ID5 (01h if not used)	01	00000001
	2F	Standard timing ID5 (01h if not used)	01	00000001
	30	Standard timing ID6 (01h if not used)	01	00000001
	31	Standard timing ID6 (01h if not used)	01	00000001
	32	Standard timing ID7 (01h if not used)	01	00000001
	33	Standard timing ID7 (01h if not used)	01	00000001
	34	Standard timing ID8 (01h if not used)	01	00000001
35	Standard timing ID8 (01h if not used)	01	00000001	
Timing Descriptor #1	36	Pixel Clock/10,000 (Pixel Clock=57.5MHz) (LSB)	76	01110110
	37	Pixel Clock/10,000 (Pixel Clock=57.5MHz) (MSB)	16	00010110
	38	Horizontal Active=1024 pixels (lower 8 bits)	00	00000000
	39	Horizontal Blanking (Thbp) = 454 pixels (lower 8 bits)	C6	11000110
	3A	Horizontal Active/Horizontal blanking (Thbp) (upper4:4 bits)	41	01000001
	3B	Vertical Active = 600 lines	58	01011000
	3C	Vertical Blanking (Tvbp) = 48 lines(DE Blanking typ. for DE only panels)	30	00110000
	3D	Vertical Active : Vertical Blanking (Tvbp) (upper4:4 bits)	20	00100000
	3E	Horizontal Sync, Offset (Thfp) = 48 pixels	20	00100000
	3F	Horizontal Sync, Pulse Width = 32 pixels	20	00100000
	40	Vertical Sync, Offset (Tvfp) = 3 lines Sync Width = 6 lines	36	00110110
	41	Horizontal Vertical Sync Offset/Width upper 2 bits	00	00000000
	42	Horizontal Image Size =222 mm	DE	11011110
	43	Vertical image Size = 125 mm	7D	01111101
	44	Horizontal Image Size / Vertical image size	00	00000000
	45	Horizontal Border = 0 (Zero for Notebook LCD)	00	00000000
	46	Vertical Border = 0 (Zero for Notebook LCD)	00	00000000
47	Non-interlaced, Normal, no stereo, Separate sync, H/V pol Negatives, DE only note: LSB is set to "1" if panel is DE-timing only. H/V can be ignored.	18	00011000	
Timing Descriptor #2	48	Pixel Clock/10,000 (Pixel Clock=57.5Hz) (LSB)	76	01110110
	49	Pixel Clock/10,000 (Pixel Clock=57.5MHz) (MSB)	16	00010110
	4A	Horizontal Active = 1024 pixels (lower 8 bits)	00	00000000
	4B	Horizontal Blanking (Thbp) = 454 pixels (lower 8 bits)	C6	11000110
	4C	Horizontal Active/Horizontal blanking (Thbp) (upper4:4 bits)	41	01000001
	4D	Vertical Active = 600 lines	58	01011000
4E	Vertical Blanking (Tvbp) = 48 lines (DE Blanking typ. for DE only panels)	30	00110000	

	4F	Vertical Active : Vertical Blanking (Tvbp) (upper4:4 bits)	20	00100000
	50	Horizontal Sync, Offset (Thfp) = 48 pixels	30	00110000
	51	Horizontal Sync, Pulse Width = 32 pixels	20	00100000
	52	Vertical Sync, Offset (Tvfp) = 3 lines Sync Width = 6 lines	36	00110110
	53	Horizontal Vertical Sync Offset/Width upper 2 bits	00	00000000
	54	Horizontal Image Size =222mm	DE	11011110
	55	Vertical image Size = 125 mm	7D	01111101
	56	Horizontal Image Size / Vertical image size	00	00000000
	57	Horizontal Border = 0 (Zero for Notebook LCD)	00	00000000
	58	Vertical Border = 0 (Zero for Notebook LCD)	00	00000000
	59	Non-interlaced, Normal, no stereo, Separate sync, H/V pol Negatives, DE only note: LSB is set to "1" if panel is DE-timing only. H/V can be ignored.	18	00011000
Timing Descriptor #3 Dell specific information	5A	Flag	00	00000000
	5B	Flag	00	00000000
	5C	Flag	00	00000000
	5D	Dummy Descriptor	FE	11111110
	5E	Flag	00	00000000
	5F	Dell P/N 1 st Character "N"	4E	01001110
	60	Dell P/N 2 nd Character "X"	58	01011000
	61	Dell P/N 3 rd Character "V"	56	01010110
	62	Dell P/N 4 th Character "4"	34	00110100
	63	Dell P/N 5 th Character "P"	50	01010000
	64	LCD Supplier EEDID Revision #	14	00010100
	65	Manufacturer P/N "1"	31	00110001
	66	Manufacturer P/N "0"	30	00110000
	67	Manufacturer P/N "1"	31	00110001
	68	Manufacturer P/N "I"	49	01001001
69	Manufacturer P/N "W"	57	01010111	
6A	Manufacturer P/N "0"	30	00110000	
6B	Manufacturer P/N (If <13 char, then terminate with ASCII code 0Ah, set remaining char = 20h) "4"	34	00110100	
Timing Descriptor #4	6C	Flag	00	00000000
	6D	Flag	00	00000000
	6E	Flag	00	00000000
	6F	Data Type Tag: Manufacturer Specified Data 00	00	00000000
	70	Flag	00	00000000
	71	Color Management	00	00000000
	72	Panel Type and Revision	41	01000001
	73	Frame Rate	00	00000000
	74	Light Controller Interface and Maximum Luminance (200nit)	94	10010100
	75	Outdoor Features and Polarizer	00	00000000
	76	Multi-Media Features	00	00000000
77	Multi-Media Features	00	00000000	
78	Special Features	00	00000000	

	79	Special Features	01	00000001
	7A	Special Features	01	00000001
	7B	(If <13 char, then terminate with ASCII code 0Ah, set remaining char = 20h)	0A	00001010
	7C	(If <13 char, then terminate with ASCII code 0Ah, set remaining char = 20h)	20	00100000
	7D	(If <13 char, then terminate with ASCII code 0Ah, set remaining char = 20h)	20	00100000
Checksum	7E	Extension flag (# of optional 128 EDID extension blocks to follow, Typ = 0)	00	00000000
	7F	Checksum (The 1-byte sum of all 128 bytes in this EDID block shall = 0)	B3	10110011

10. Mechanical drawings

10-1. Front Side

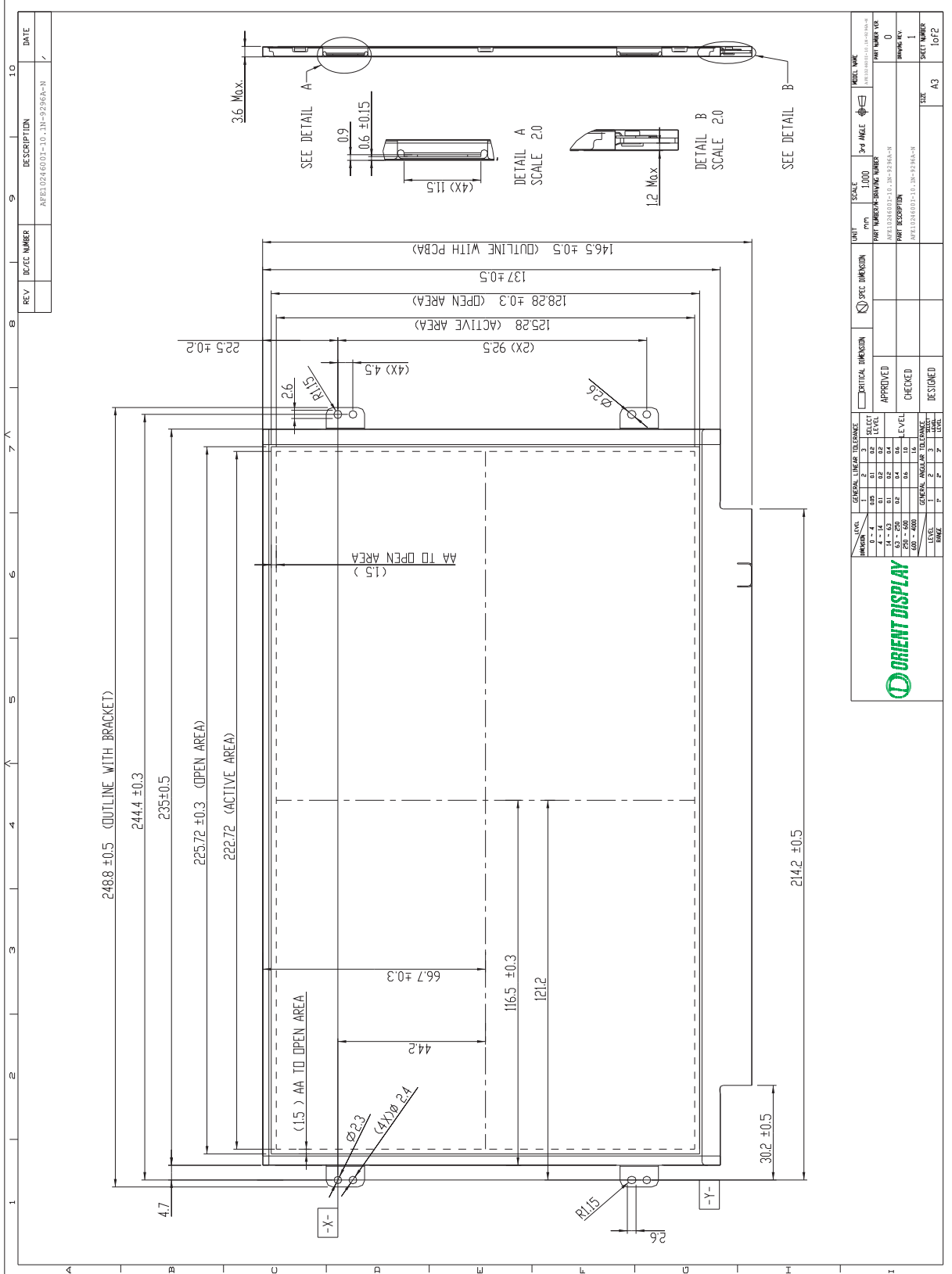

10-2. Rear Side

