



## 1jGeneral Description

AFN1026S, N-Channel enhancement mode MOSFET, uses Advanced Trench Technology to provide excellent  $R_{DS(ON)}$ , low gate charge.

These devices are particularly suited for low voltage power management, such as smart phone and notebook computer, and low in-line power loss are needed in commercial industrial surface mount applications.

## Features

- 60V/0.5A ,  $R_{DS(ON)}=2.4\Omega@V_{GS}=10V$
- 60V/0.2A ,  $R_{DS(ON)}=3.0\Omega@V_{GS}=4.5V$
- Super high density cell design for extremely low  $R_{DS(ON)}$
- Exceptional on-resistance and maximum DC current capability
- ESD Protection ( >2KV ) Diode design-in
- SOT-563 package design

## Pin Description ( SOT-563 )

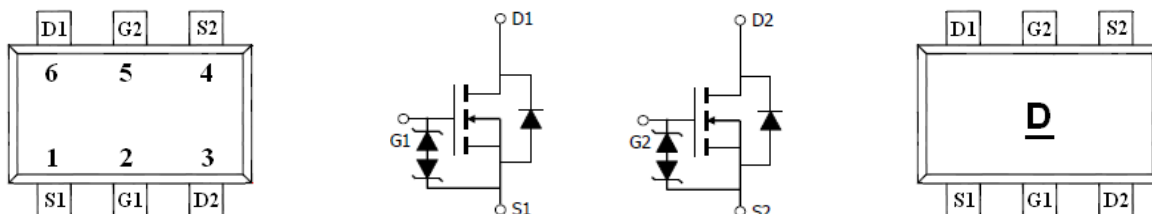

## Application

- Drivers: Relays, Solenoids, Lamps, Hammers, Displays, Memories
- Battery Operated Systems
- Power Supply Converter Circuits
- Load/Power Switching Smart Phones, Pagers

## Pin Define

Pin	Symbol	Description
1	S1	Source 1
2	G1	Gate 1
3	D2	Drain 2
4	S2	Source 2
5	G2	Gate 2
6	D1	Drain1

## Ordering Information

Part Ordering No.	Part Marking	Package	Unit	Quantity
AFN1026SS56RG	<u>D</u>	SOT-563	Tape & Reel	3000 EA

※ AFN1026SS56RG : 7" Tape & Reel ; Pb- Free ; Halogen- Free



**Absolute Maximum Ratings**

(T<sub>A</sub>=25°C Unless otherwise noted)

Parameter	Symbol	Typical	Unit
Drain-Source Voltage	V <sub>DSS</sub>	60	V
Gate –Source Voltage	V <sub>GSS</sub>	±20	V
Continuous Drain Current(T <sub>J</sub> =150°C)	I <sub>D</sub>	T <sub>A</sub> =25°C	0.35
		T <sub>A</sub> =70°C	0.23
Pulsed Drain Current	I <sub>DM</sub>	0.65	A
Continuous Source Current(Diode Conduction)	I <sub>S</sub>	0.25	A
Power Dissipation	P <sub>D</sub>	T <sub>A</sub> =25°C	0.25
		T <sub>A</sub> =70°C	0.15
Operating Junction Temperature	T <sub>J</sub>	-55/150	°C
Storage Temperature Range	T <sub>STG</sub>	-55/150	°C

**Electrical Characteristics**

(T<sub>A</sub>=25°C Unless otherwise noted)

Parameter	Symbol	Conditions	Min.	Typ	Max.	Unit
<b>Static</b>						
Drain-Source Breakdown Voltage	V <sub>(BR)DSS</sub>	V <sub>GS</sub> =0V, I <sub>D</sub> =250uA	60			V
Gate Threshold Voltage	V <sub>GS(th)</sub>	V <sub>DS</sub> =V <sub>GS</sub> , I <sub>D</sub> =250uA	1.0		2.0	
Gate Leakage Current	I <sub>GSS</sub>	V <sub>DS</sub> =0V, V <sub>GS</sub> =±20V			3	uA
Zero Gate Voltage Drain Current	I <sub>DSS</sub>	V <sub>DS</sub> =60V, V <sub>GS</sub> =0V			1	uA
		V <sub>DS</sub> =60V, V <sub>GS</sub> =0V T <sub>J</sub> =85°C			10	
Drain-Source On-Resistance	R <sub>DS(on)</sub>	V <sub>GS</sub> =10V, I <sub>D</sub> =0.5A		1.2	2.4	Ω
		V <sub>GS</sub> = 4.5V, I <sub>D</sub> =0.2A		1.7	3.0	
Forward Transconductance	g <sub>FS</sub>	V <sub>DS</sub> =10V, I <sub>D</sub> =0.2A		0.2		S
Diode Forward Voltage	V <sub>SD</sub>	I <sub>S</sub> =0.2A, V <sub>GS</sub> =0V		0.75	1.4	V
<b>Dynamic</b>						
Total Gate Charge	Q <sub>g</sub>	V <sub>DS</sub> =10V, V <sub>GS</sub> =4.5V I <sub>D</sub> ≅0.25A		450		pC
Gate-Source Charge	Q <sub>gs</sub>			110		
Gate-Drain Charge	Q <sub>gd</sub>			150		
Input Capacitance	C <sub>iss</sub>	V <sub>DS</sub> =25V, V <sub>GS</sub> =0V f=1MHz		30		pF
Output Capacitance	C <sub>oss</sub>			8		
Reverse Transfer Capacitance	C <sub>rss</sub>			5		
Turn-On Time	t <sub>d(on)</sub>	V <sub>DD</sub> =30V, R <sub>L</sub> =150Ω I <sub>D</sub> ≅0.2A, V <sub>GEN</sub> =10V R <sub>G</sub> =10Ω		4	10	ns
	t <sub>r</sub>			5	15	
Turn-Off Time	t <sub>d(off)</sub>			12	20	
	t <sub>f</sub>			10	20	



## Typical Characteristics

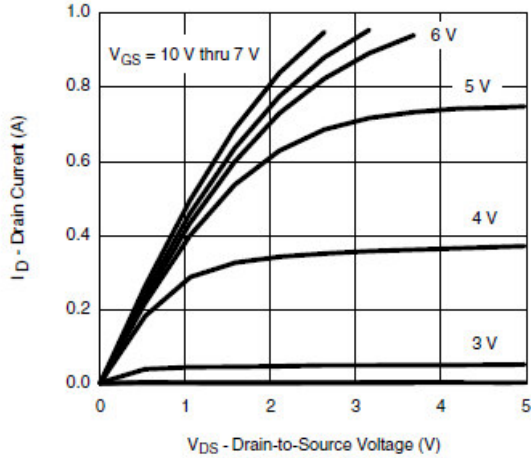

Output Characteristics

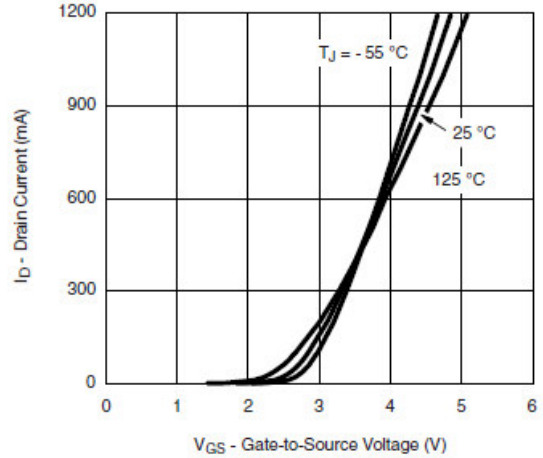

Transfer Characteristics

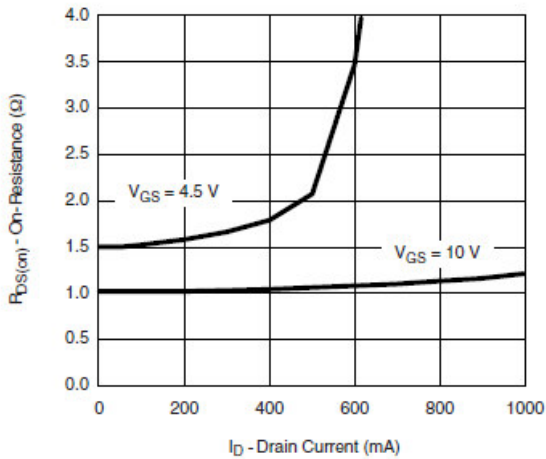

On-Resistance vs. Drain Current

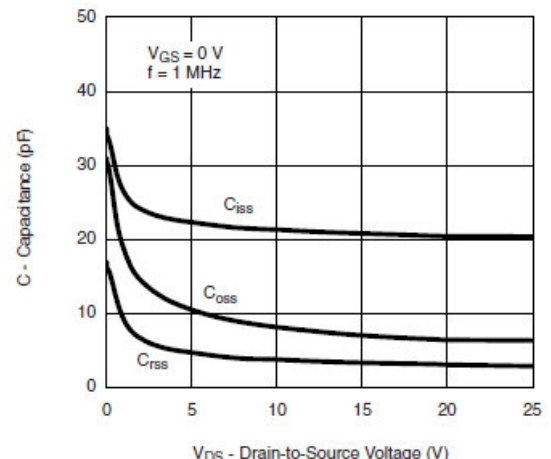

Capacitance

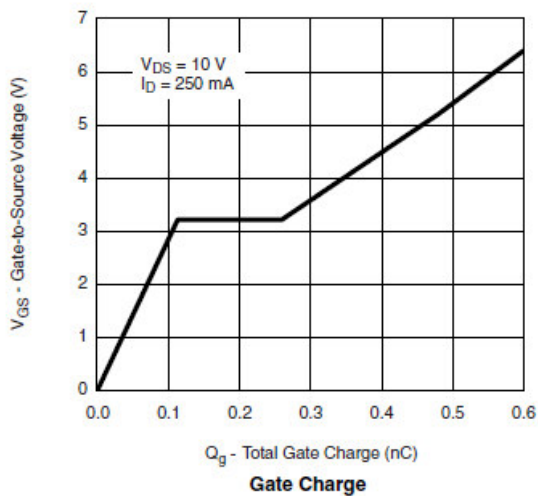

Gate Charge

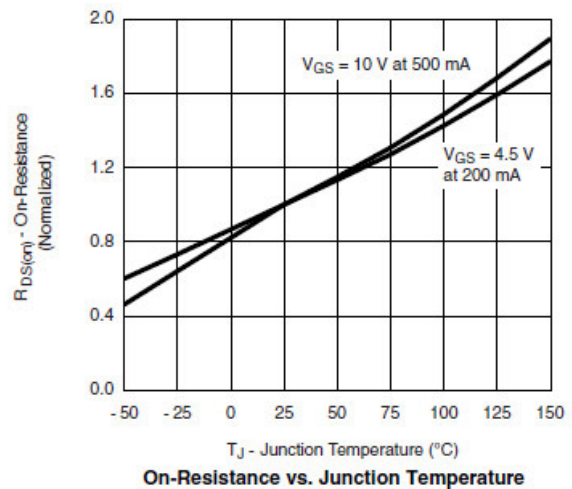

On-Resistance vs. Junction Temperature



## Typical Characteristics

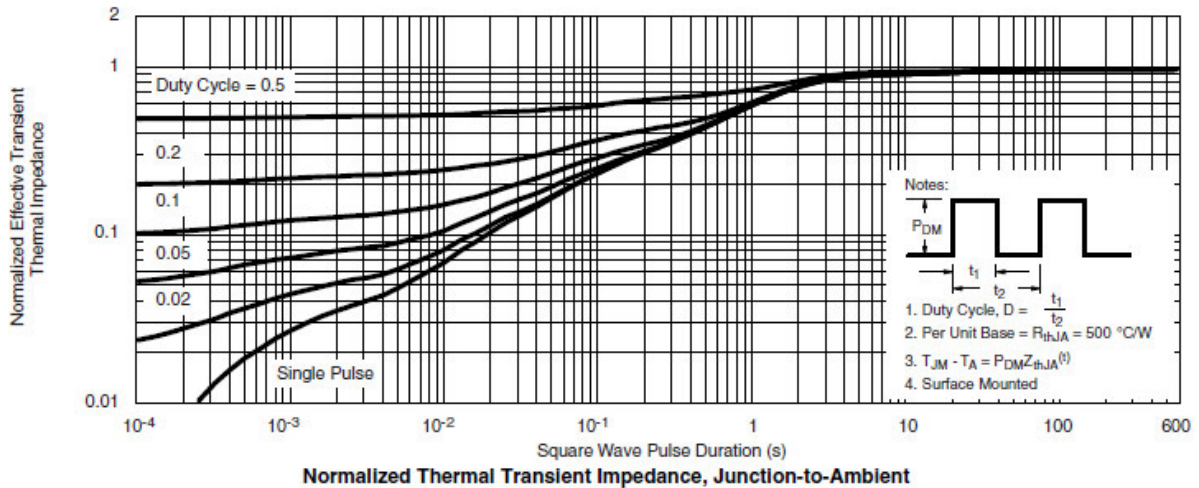
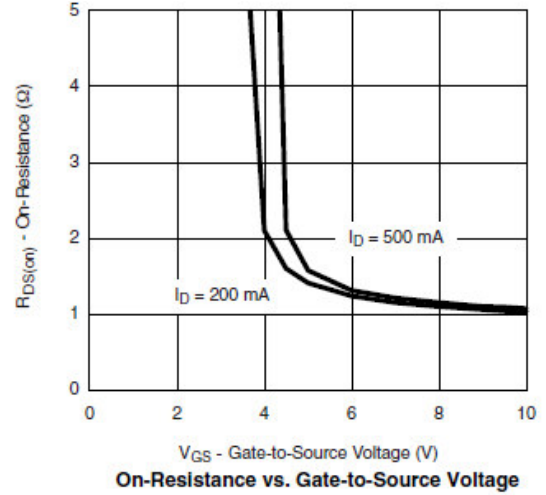
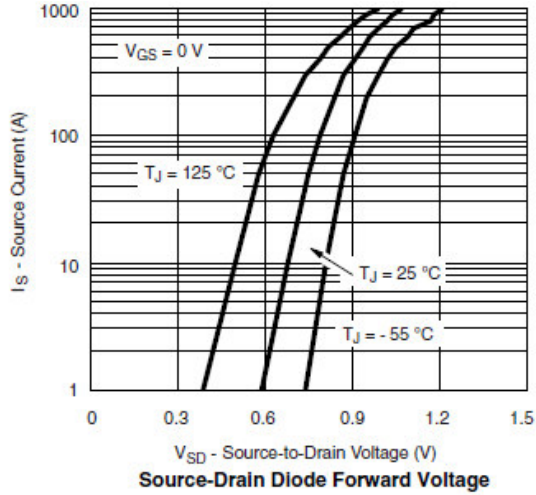



**Typical Characteristics**

Gate Charge Test Circuit & Waveform



Resistive Switching Test Circuit & Waveforms

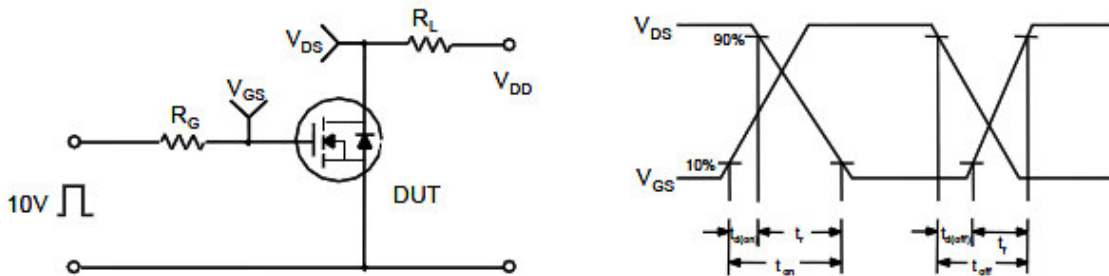

Unclamped Inductive Switching Test Circuit & Waveforms

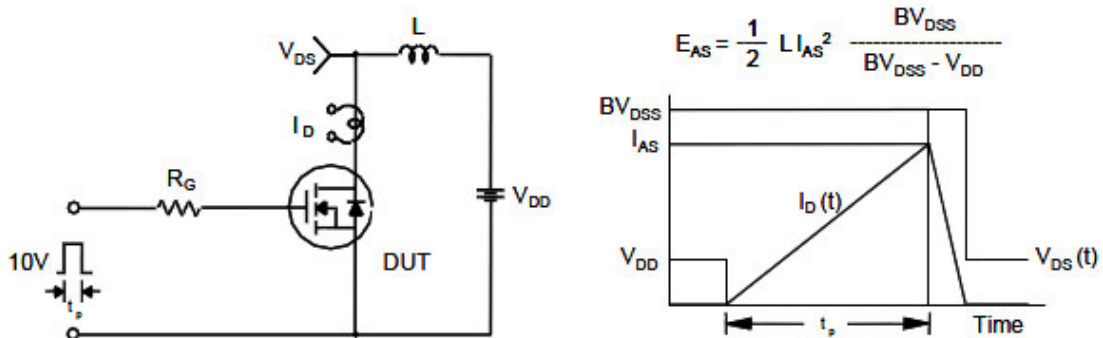



**Package Information ( SOT-563 )**

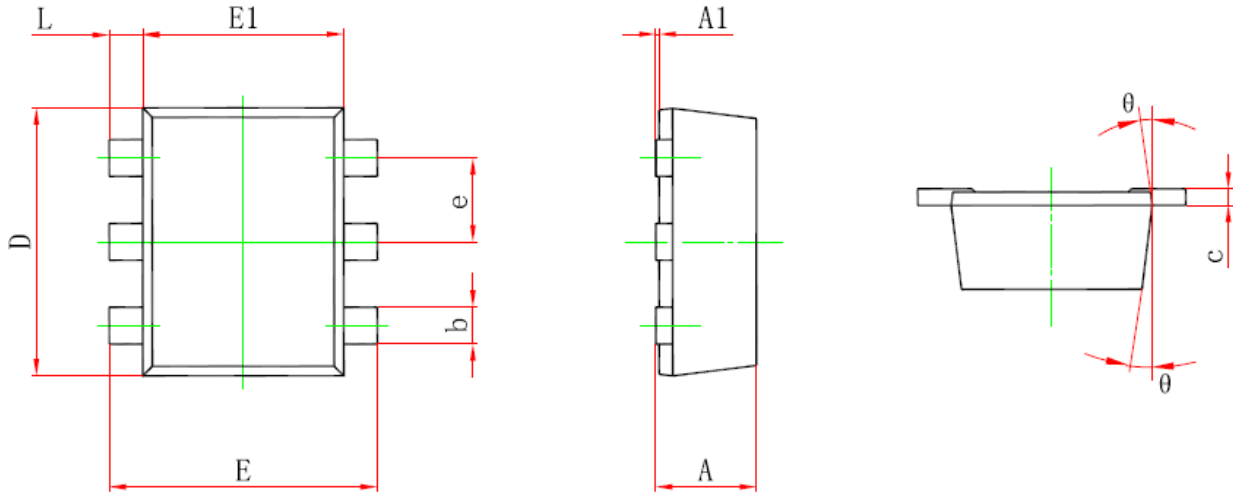

Symbol	Dimensions In Millimeters		Dimensions In Inches	
	Min.	Max.	Min.	Max.
A	0.525	0.600	0.021	0.024
A1	0.000	0.050	0.000	0.002
e	0.450	0.550	0.018	0.022
c	0.090	0.160	0.004	0.006
D	1.500	1.700	0.059	0.067
b	0.170	0.270	0.007	0.011
E1	1.100	1.300	0.043	0.051
E	1.500	1.700	0.059	0.067
L	0.100	0.300	0.004	0.012
θ	7 °REF.		7 °REF.	

©2010 Alfa-MOS Technology Corp.  
2F, No.80, Sec.1, Cheng Kung Rd., Nan Kang Dist., Taipei City 115, Taiwan (R.O.C.)  
Tel : 886 2) 2651 3928  
Fax : 886 2) 2786 8483  
©http://www.alfa-mos.com