



General Description

AFN2440WS, N-Channel enhancement mode MOSFET, uses Advanced Trench Technology to provide excellent $R_{DS(ON)}$, low gate charge. These devices are particularly suited for low voltage power management, and low in-line power loss are needed in commercial industrial surface mount applications.

Features

- 40V/ 9A, $R_{DS(ON)} = 20m\Omega @ V_{GS} = 10V$
- 40V/ 7A, $R_{DS(ON)} = 25m\Omega @ V_{GS} = 4.5V$
- Super high density cell design for extremely low $R_{DS(ON)}$
- DFN2X2-6L package design

Pin Description (DFN2X2-6L)

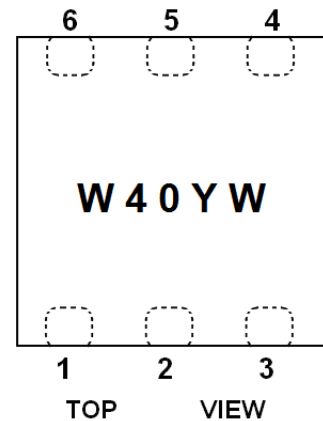
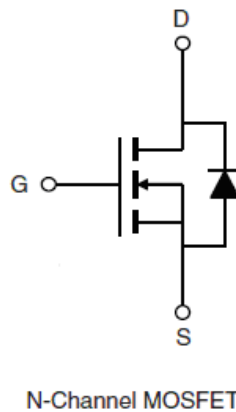
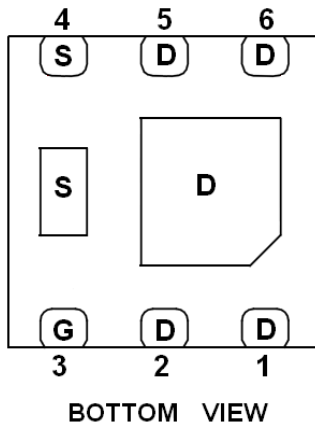

Application

- DC/DC Converter
- High Frequency Switching

Pin Define

Pin	Symbol	Description
1,2,5,6	D	Drain
4	S	Source
3	G	Gate

Ordering Information

Part Ordering No.	Part Marking	Package	Unit	Quantity
AFN2440WSFN226RG	W40YW	DFN2X2-6L	Tape & Reel	4000 EA

- ※ W40 part code
- ※ Y year code
- ※ W week code
- ※ AFN2440WSFN226RG : 7" Tape & Reel ; Pb- Free ; Halogen- Free



Absolute Maximum Ratings

(T_A=25°C Unless otherwise noted)

Parameter	Symbol	Typical	Unit
Drain-Source Voltage	V _{DSS}	40	V
Gate –Source Voltage	V _{GSS}	±20	V
Continuous Drain Current(T _J =150°C)	I _D	T _A =25°C	9
		T _A =70°C	7
Pulsed Drain Current	I _{DM}	40	A
Continuous Source Current(Diode Conduction)	I _S	2.9	A
Power Dissipation	P _D	T _A =25°C	3.5
		T _A =70°C	2.2
Operating Junction Temperature	T _J	150	°C
Storage Temperature Range	T _{STG}	-55/150	°C
Thermal Resistance-Junction to Ambient	R _{θJA}	36	°C/W

Electrical Characteristics

(T_A=25°C Unless otherwise noted)

Parameter	Symbol	Conditions	Min.	Typ	Max.	Unit
Static						
Drain-Source Breakdown Voltage	V _{(BR)DSS}	V _{GS} =0V, I _D =250uA	40			V
Gate Threshold Voltage	V _{GS(th)}	V _{DS} =V _{GS} , I _D =250uA	1.0		2.0	V
Gate Leakage Current	I _{GSS}	V _{DS} =0V, V _{GS} =±20V			±100	nA
Zero Gate Voltage Drain Current	I _{DSS}	V _{DS} =32V, V _{GS} =0V			1	uA
		V _{DS} =32V, V _{GS} =0V T _J =85°C			10	
On-State Drain Current	I _{D(on)}	V _{DS} ≥ 5V, V _{GS} =10V	10			A
Drain-Source On-Resistance	R _{DS(on)}	V _{GS} =10V, I _D =9A		15	20	mΩ
		V _{GS} =4.5V, I _D =7A		17	25	
Forward Transconductance	g _{FS}	V _{DS} =15V, I _D =8A		30		S
Diode Forward Voltage	V _{SD}	I _S =10A, V _{GS} =0V		0.85	1.2	V
Dynamic						
Total Gate Charge	Q _g	V _{DS} =10V, V _{GS} =4.5V I _D = 10A		10	15	nC
Gate-Source Charge	Q _{gs}			4.5		
Gate-Drain Charge	Q _{gd}			3.0		
Input Capacitance	C _{iss}	V _{DS} =20V, V _{GS} =0V f=1MHz		1350		pF
Output Capacitance	C _{oss}			150		
Reverse Transfer Capacitance	C _{rss}			70		
Turn-On Time	t _{d(on)}	V _{DD} =20V, R _L =2.5Ω I _D ≧8A, V _{GEN} =10V R _G =1Ω		10	20	ns
	t _r			15	30	
Turn-Off Time	t _{d(off)}			20	40	
	t _f			10	20	



Typical Characteristics

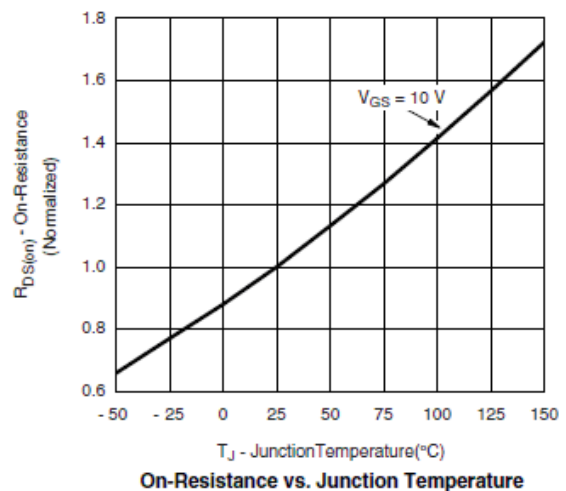
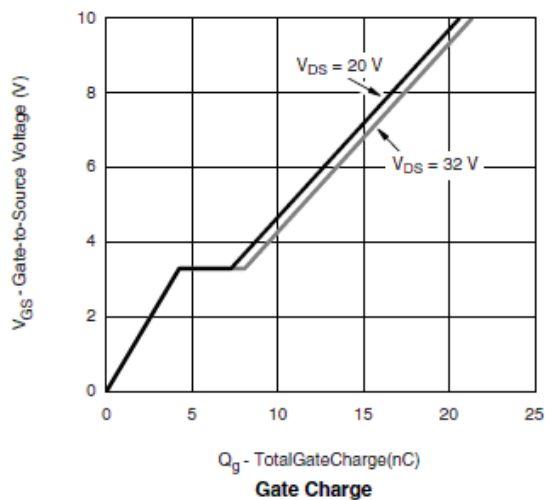
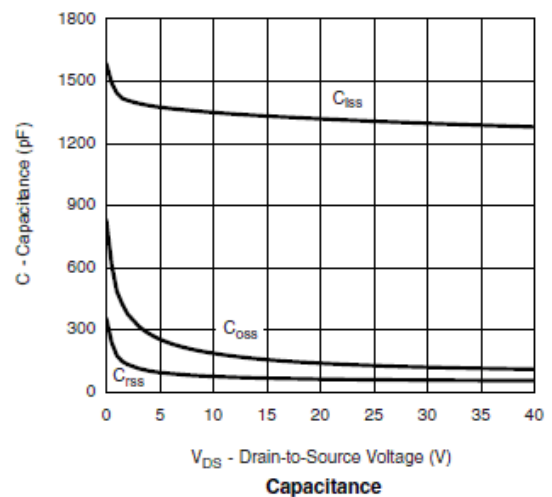
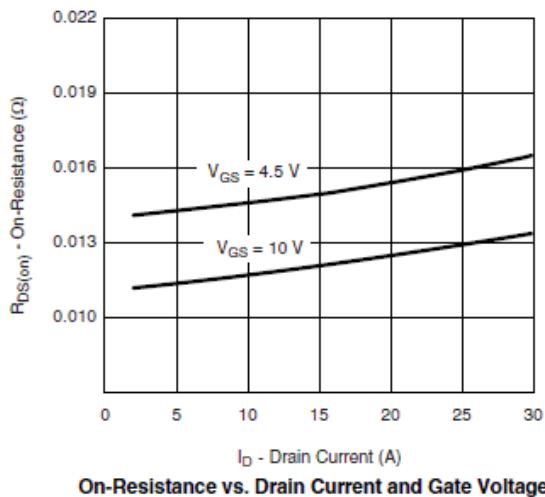
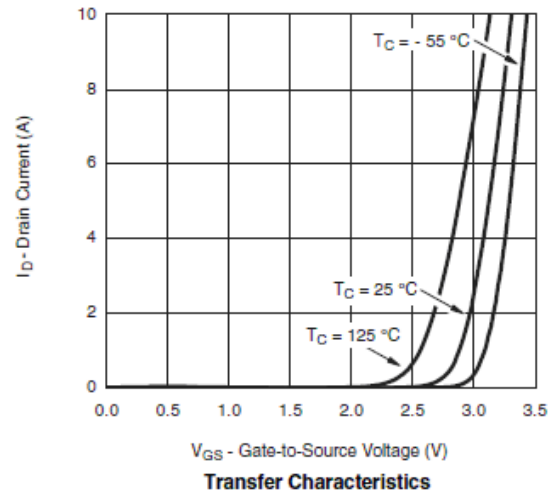
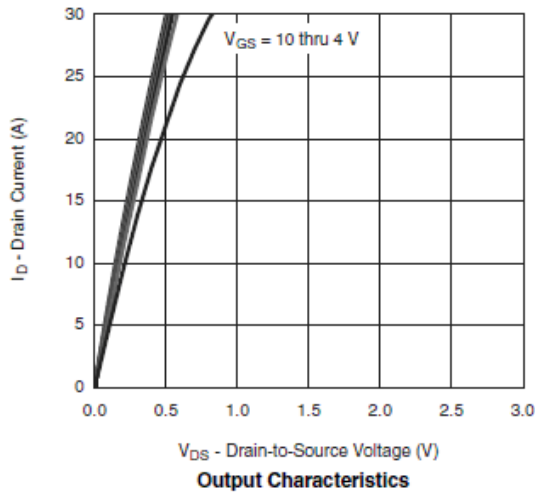



Typical Characteristics

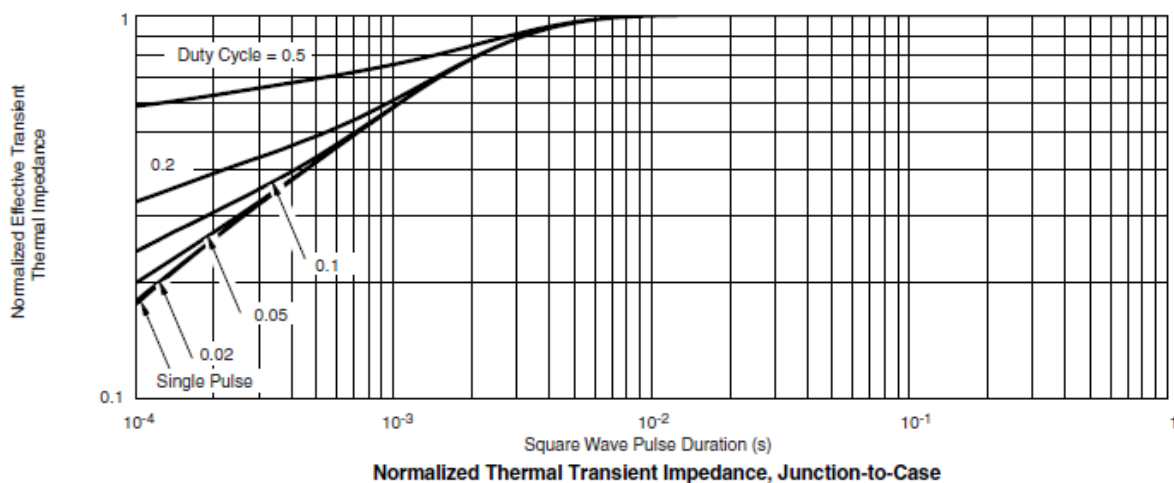
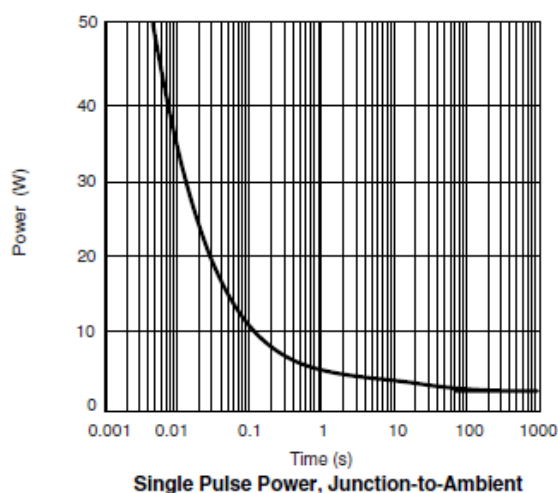
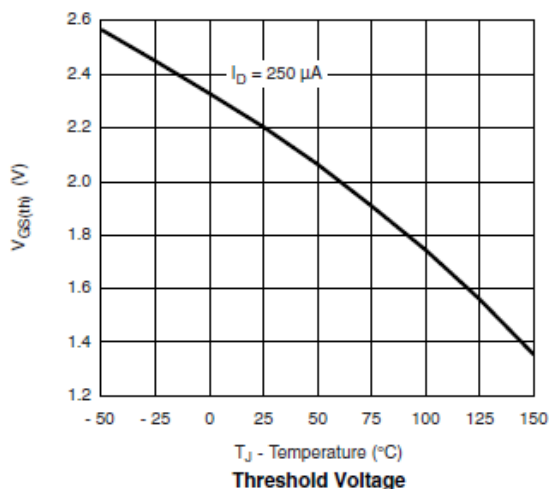
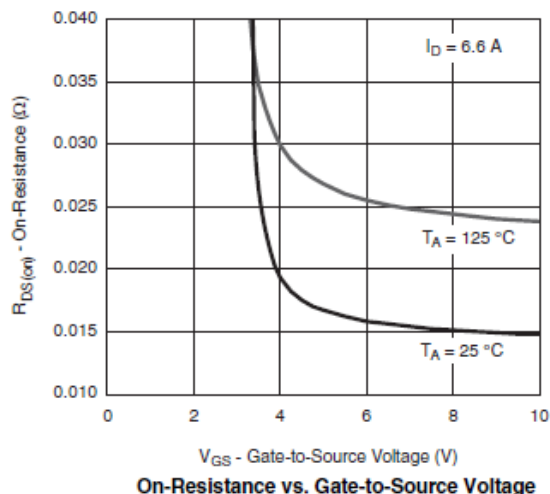
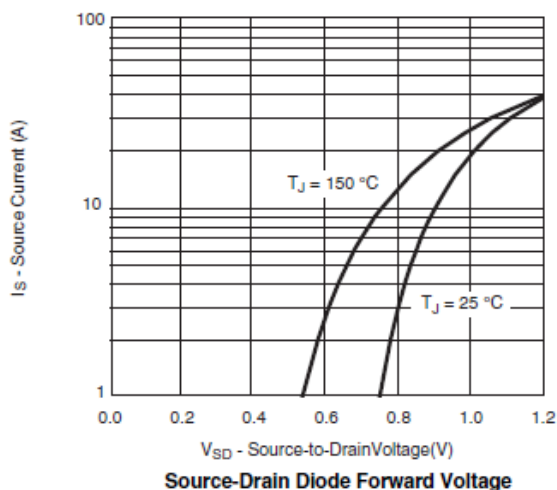



Typical Characteristics

Gate Charge Test Circuit & Waveform

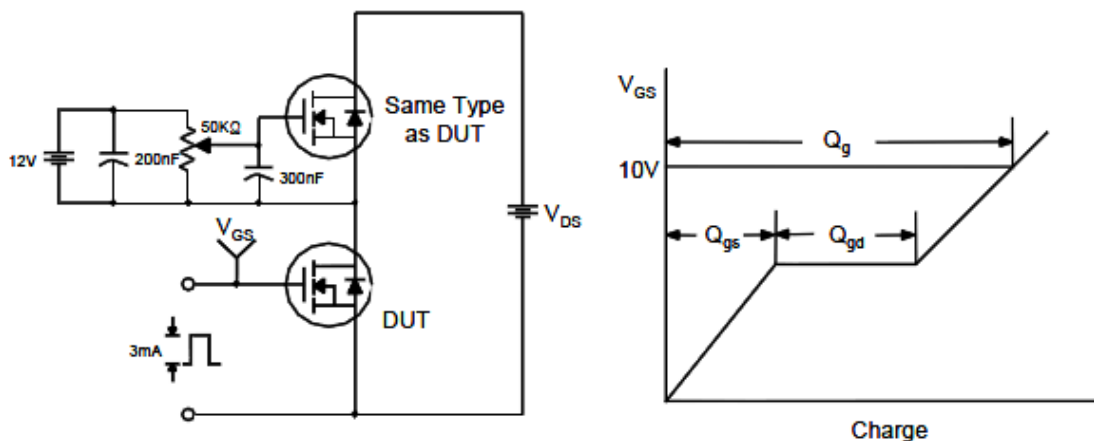

Resistive Switching Test Circuit & Waveforms

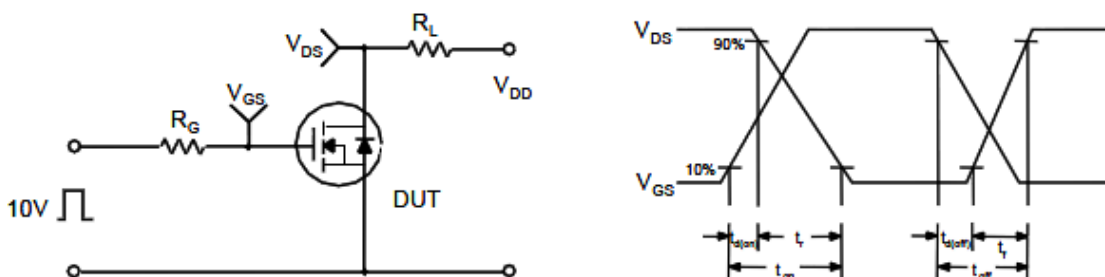

Unclamped Inductive Switching Test Circuit & Waveforms

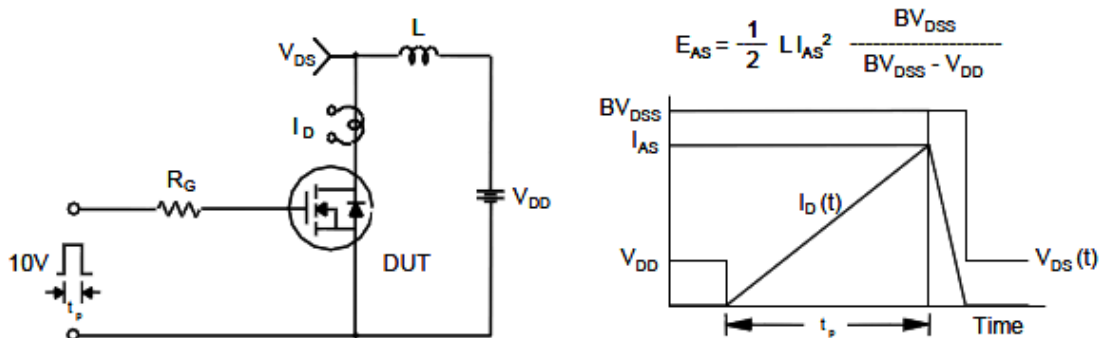



Package Information (DFN2X2-6L)

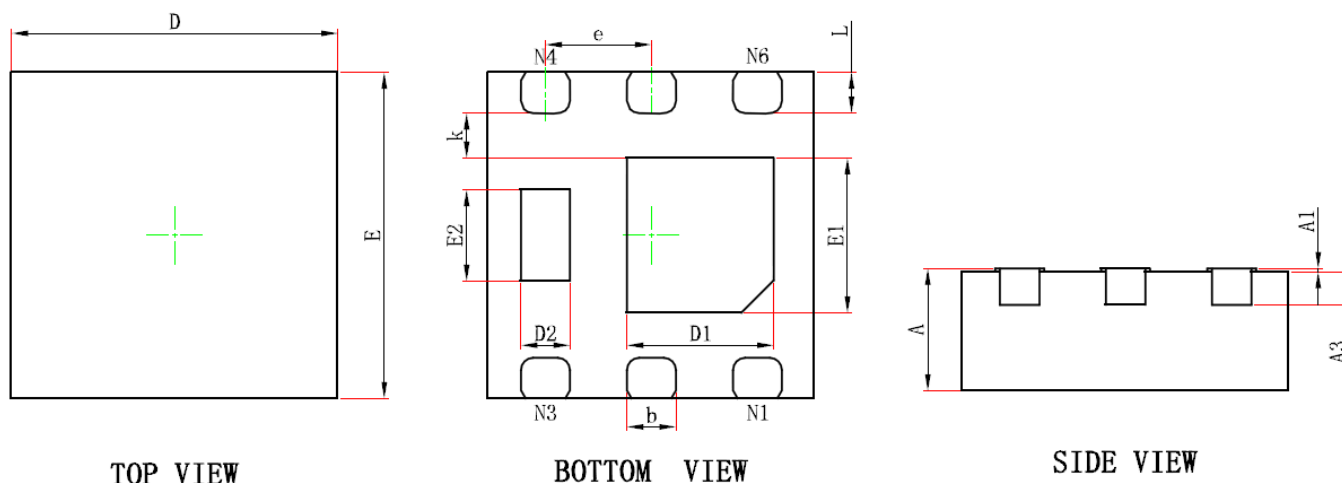

Symbol	Dimensions In Millimeters		Dimensions In Inches	
	Min.	Max.	Min.	Max.
A	0.700	0.800	0.028	0.031
A1	0.000	0.050	0.000	0.002
A3	0.203REF.		0.008REF.	
D	1.924	2.076	0.076	0.082
E	1.924	2.076	0.076	0.082
D1	0.800	1.000	0.031	0.039
E1	0.850	1.050	0.033	0.041
D2	0.200	0.400	0.008	0.016
E2	0.460	0.660	0.018	0.026
k	0.200MIN.		0.008MIN.	
b	0.250	0.350	0.010	0.014
e	0.650TYP.		0.026TYP.	
L	0.174	0.326	0.007	0.013

©2010 Alfa-MOS Technology Corp.
 2F, No.80, Sec.1, Cheng Kung Rd., Nan Kang Dist., Taipei City 115, Taiwan (R.O.C.)
 Tel : 886 2) 2651 3928
 Fax : 886 2) 2786 8483
 ©http://www.alfa-mos.com