



General Description

AFN4910W, N-Channel enhancement mode MOSFET, uses Advanced Trench Technology to provide excellent $R_{DS(ON)}$, low gate charge.

These devices are particularly suited for low voltage power management, and low in-line power loss are needed in commercial industrial surface mount applications.

Features

N1 Channel

- 40V/10A, $R_{DS(ON)} = 19m\Omega @ V_{GS} = 10V$
- 40V/ 8A, $R_{DS(ON)} = 25m\Omega @ V_{GS} = 4.5V$

N2 Channel

- 40V/10A, $R_{DS(ON)} = 10m\Omega @ V_{GS} = 10V$
- 40V/ 8A, $R_{DS(ON)} = 12m\Omega @ V_{GS} = 4.5V$

Pin Description (SOP-8P)

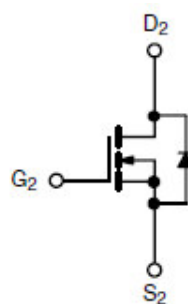
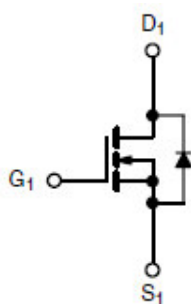
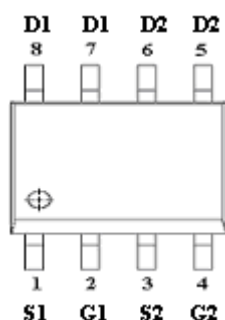

Application

- Car Charger
- POL, IBC
- Secondary Side

Pin Define

Pin	Symbol	Description
1	S1	Source 1
2	G1	Gate 1
3	S2	Source 2
4	G2	Gate 2
5	D2	Drain 2
6	D2	Drain 2
7	D1	Drain 1
8	D1	Drain 1

Ordering Information

Part Ordering No.	Part Marking	Package	Unit	Quantity
AFN4910WS8RG	4910W	SOP-8P	Tape & Reel	2500 EA

※ A Lot code

※ B Date code

※ AFN4910WS8RG : 13" Tape & Reel ; Pb- Free ; Halogen- Free



Absolute Maximum Ratings

(T_A=25°C Unless otherwise noted)

Parameter	Symbol	Typical		Unit
		N1	N2	
Drain-Source Voltage	V _{DSS}	40	40	V
Gate -Source Voltage	V _{GSS}	±20	±20	V
Continuous Drain Current(T _J =150°C)	I _D	T _A =25°C	10	A
		T _A =70°C	8	
Pulsed Drain Current	I _{DM}	20	30	A
Avalanche Current	I _{AS}	10	20	A
Avalanche Energy	E _{AS}	5	10	mJ
Continuous Source Current(Diode Conduction)	I _S	1.8	1.8	A
Power Dissipation	P _D	T _A =25°C	2.8	W
		T _A =70°C	1.8	
Operating Junction Temperature	T _J	150		°C
Storage Temperature Range	T _{STG}	-55/150		°C
Thermal Resistance-Junction to Ambient	R _{θJA}	62.5		°C/W

N1 Channel Electrical Characteristics

(T_A=25°C Unless otherwise noted)

Parameter	Symbol	Conditions	Min.	Typ	Max.	Unit
Static						
Drain-Source Breakdown Voltage	V _{(BR)DSS}	V _{GS} =0V, I _D =250uA	40			V
Gate Threshold Voltage	V _{GS(th)}	V _{DS} =V _{GS} , I _D =250uA	1.0		3.0	
Gate Leakage Current	I _{GSS}	V _{DS} =0V, V _{GS} =±20V			±100	nA
Zero Gate Voltage Drain Current	I _{DSS}	V _{DS} =40V, V _{GS} =0V			1	uA
		V _{DS} =40V, V _{GS} =0V T _J =85°C			10	
On-State Drain Current	I _{D(on)}	V _{DS} ≥ 5V, V _{GS} =10V	20			A
Drain-Source On-Resistance	R _{DS(on)}	V _{GS} =10V, I _D =10A		15.8	19	mΩ
		V _{GS} =4.5V, I _D =8A		21.5	25	
Forward Transconductance	g _{FS}	V _{DS} =15V, I _D =5.0A		25		S
Diode Forward Voltage	V _{SD}	I _S =2A, V _{GS} =0V		0.85	1.2	V
Dynamic						
Total Gate Charge	Q _g	V _{DS} =20V, V _{GS} =4.5V I _D = 10A		5	10	nC
Gate-Source Charge	Q _{gs}			1.5		
Gate-Drain Charge	Q _{gd}			1.5		
Input Capacitance	C _{iss}	V _{DS} =20V, V _{GS} =0V f=1MHz		600		pF
Output Capacitance	C _{oss}			100		
Reverse Transfer Capacitance	C _{rss}			45		
Turn-On Time	t _{d(on)}	V _{DD} =20V, R _L =2Ω I _D ≡10A, V _{GEN} =10V R _G =1Ω		7	15	ns
	t _r			9	20	
Turn-Off Time	t _{d(off)}			16	30	
	t _f			8	18	



N2 Channel Electrical Characteristics

(T_A=25°C Unless otherwise noted)

Parameter	Symbol	Conditions	Min.	Typ	Max.	Unit
Static						
Drain-Source Breakdown Voltage	V _{(BR)DSS}	V _{GS} =0V, I _D =250uA	40			V
Gate Threshold Voltage	V _{GS(th)}	V _{DS} =V _{GS} , I _D =250uA	1.0		3.0	
Gate Leakage Current	I _{GSS}	V _{DS} =0V, V _{GS} =±20V			±100	nA
Zero Gate Voltage Drain Current	I _{DSS}	V _{DS} =32V, V _{GS} =0V			1	uA
		V _{DS} =32V, V _{GS} =0V T _J =85°C			10	
On-State Drain Current	I _{D(on)}	V _{DS} ≥ 5V, V _{GS} =10V	30			A
Drain-Source On-Resistance	R _{DS(on)}	V _{GS} =10V, I _D =10A		8.8	10	mΩ
		V _{GS} =4.5V, I _D =8A		10.2	12	
Forward Transconductance	g _{FS}	V _{DS} =15V, I _D =12.4A		56		S
Diode Forward Voltage	V _{SD}	I _S =1.5A, V _{GS} =0V		0.85	1.2	V
Dynamic						
Total Gate Charge	Q _g	V _{DS} =10V, V _{GS} =4.5V I _D = 8A		15	30	nC
Gate-Source Charge	Q _{gs}			6.8		
Gate-Drain Charge	Q _{gd}			5.2		
Input Capacitance	C _{iss}	V _{DS} =20V, V _{GS} =0V f=1MHz		2000		pF
Output Capacitance	C _{oss}			260		
Reverse Transfer Capacitance	C _{rss}			150		
Turn-On Time	t _{d(on)}	V _{DD} =20V, R _L =2Ω I _D ≅8A, V _{GEN} =10V R _G =1Ω		10	20	ns
	t _r			15	30	
Turn-Off Time	t _{d(off)}			30	60	
	t _f			10	20	



N1 Channel Typical Characteristics

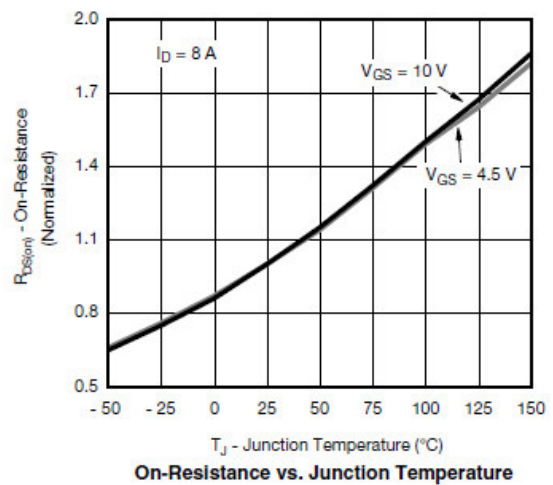
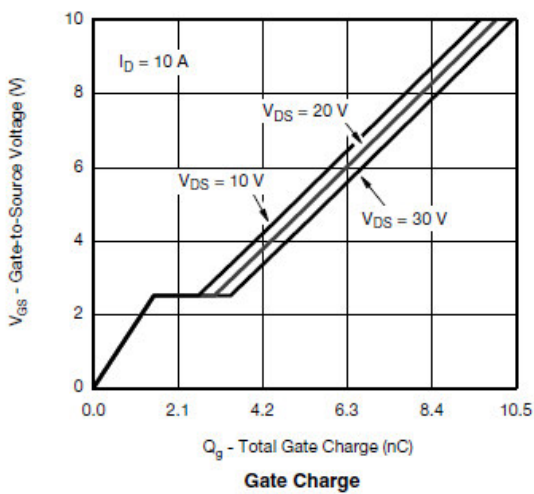
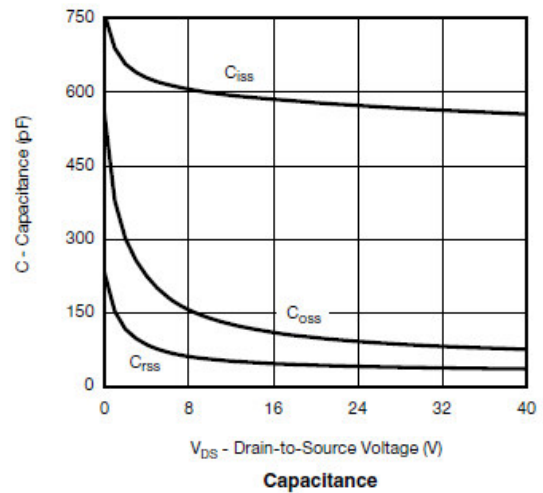
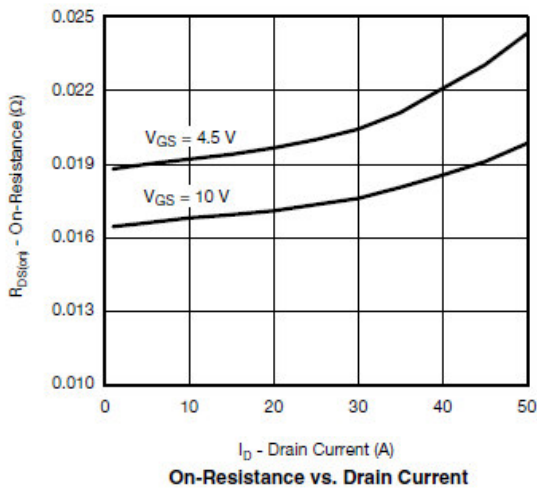
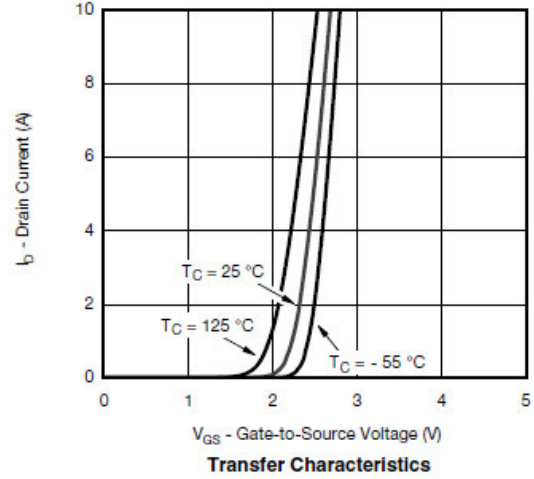
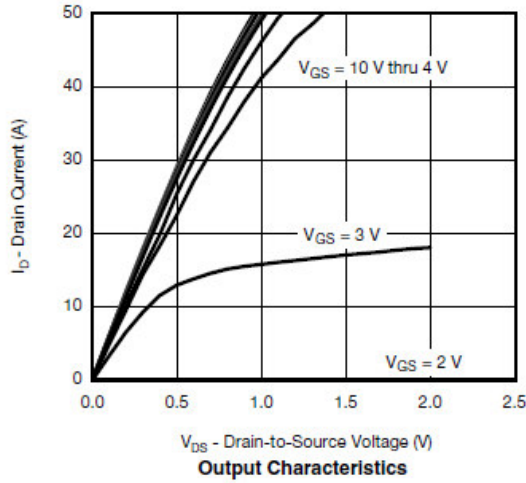



N1 Channel Typical Characteristics

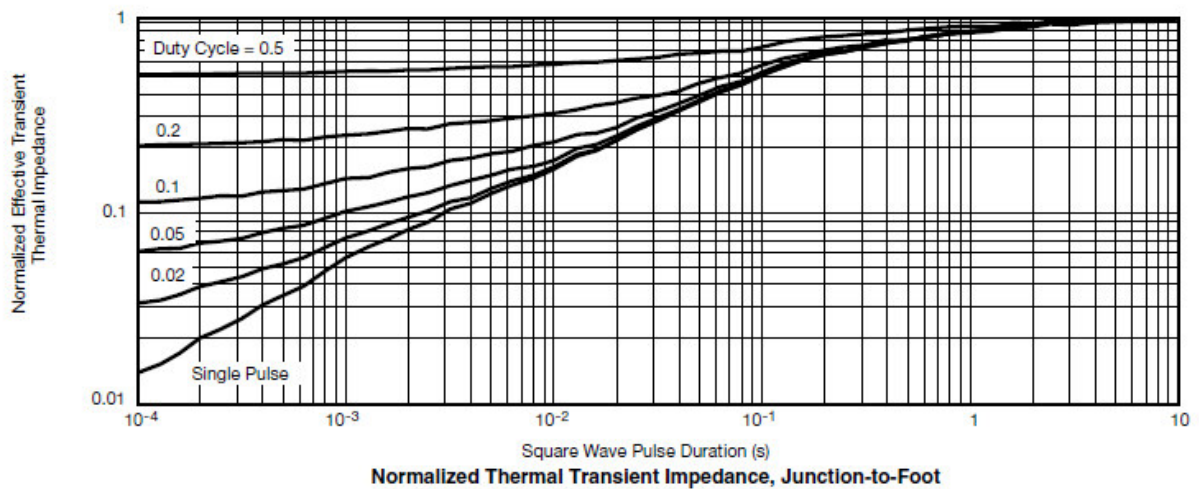
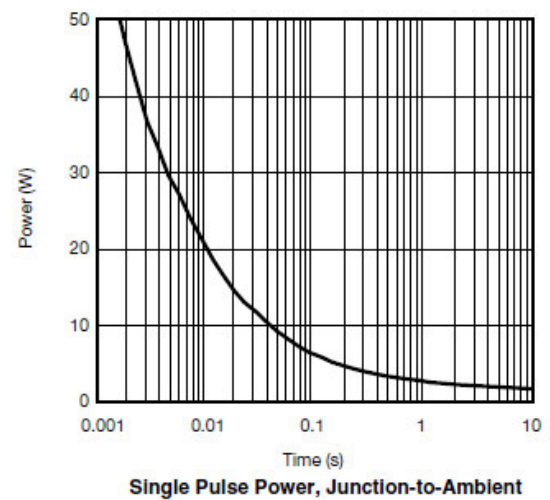
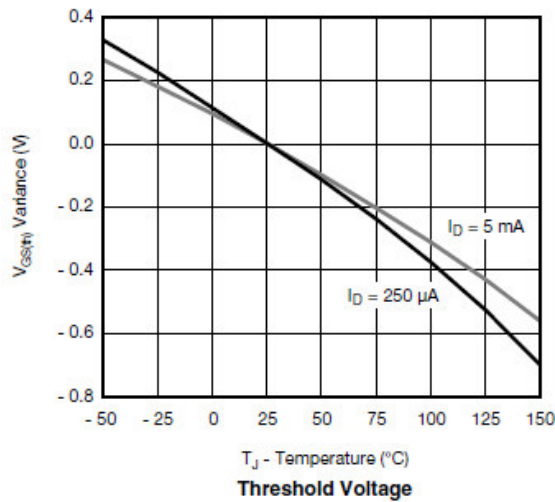
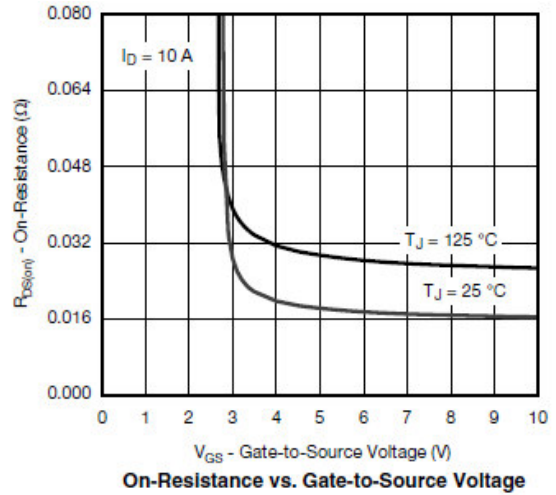
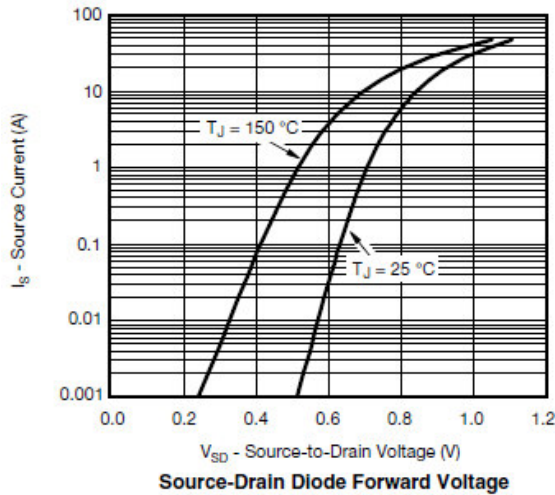



N2 Channel Typical Characteristics

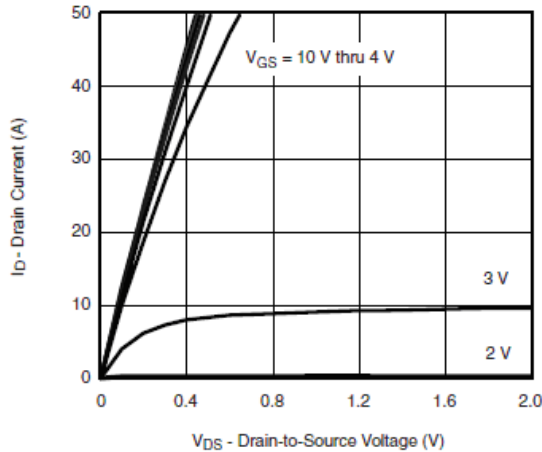

Output Characteristics

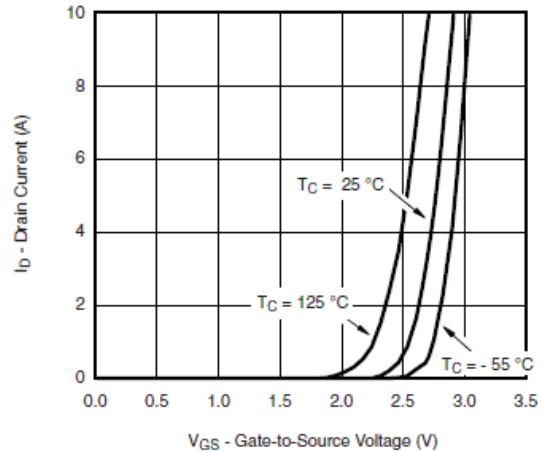

Transfer Characteristics

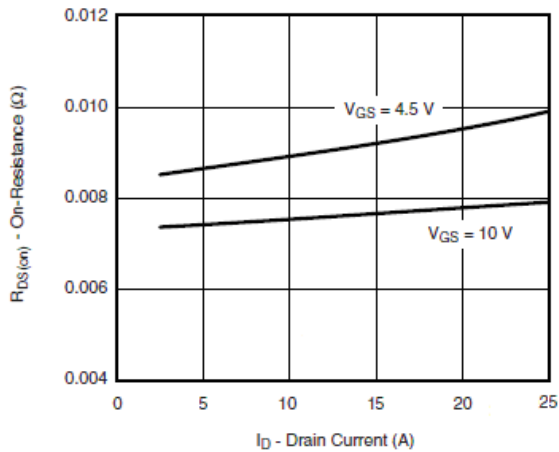

On-Resistance vs. Drain Current and Gate Voltage

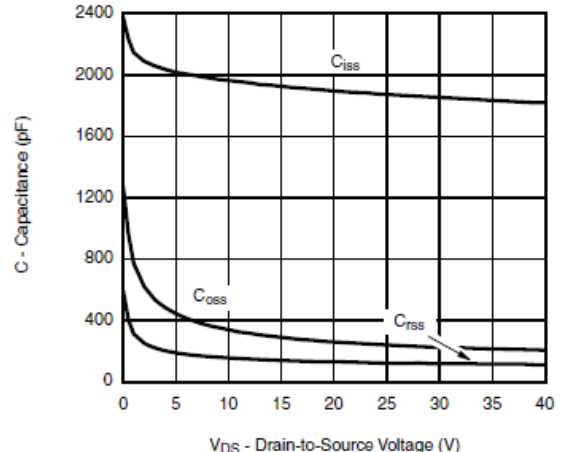

Capacitance

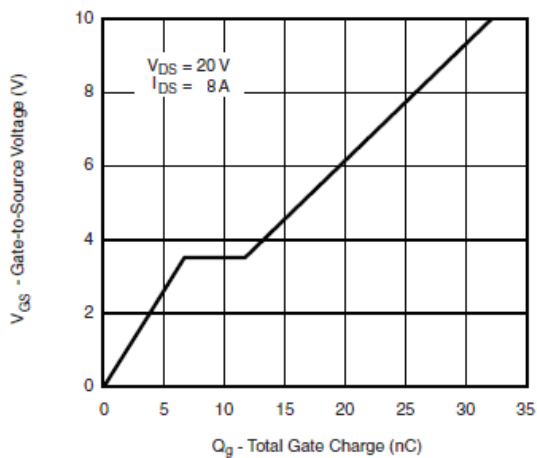

Gate Charge

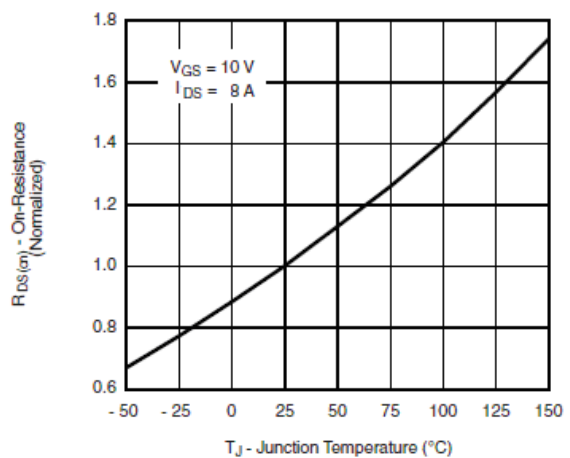

On-Resistance vs. Junction Temperature



N2 Channel Typical Characteristics

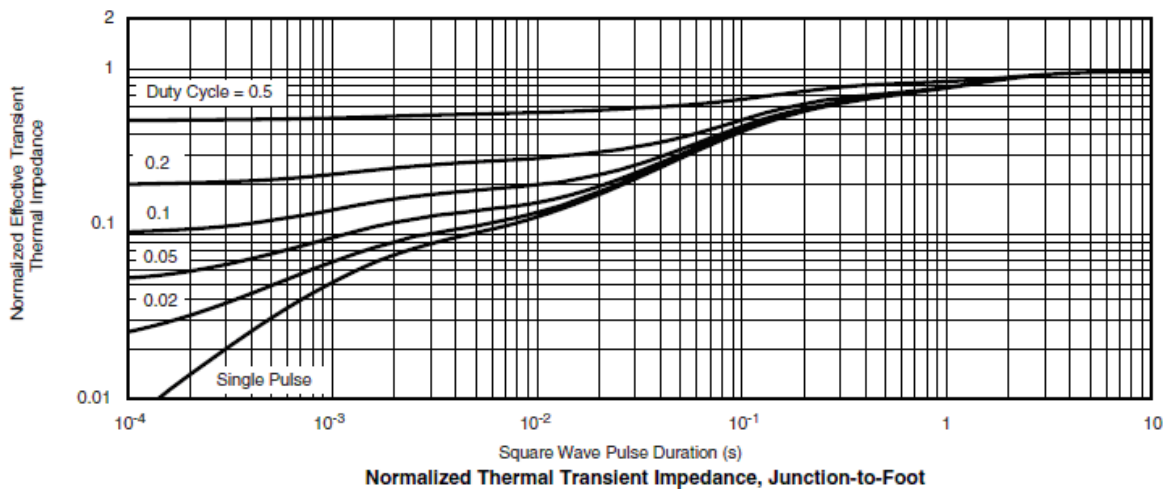
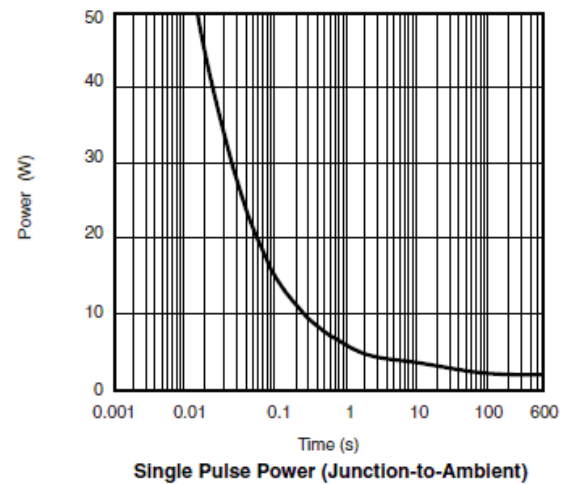
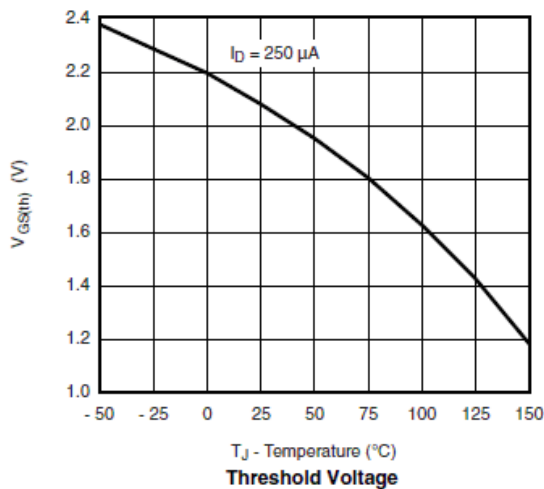
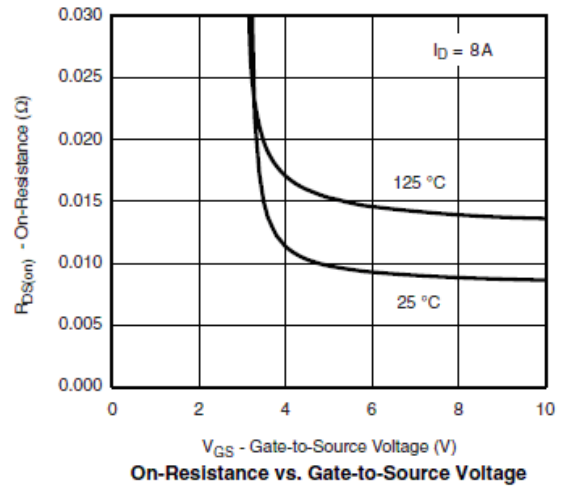
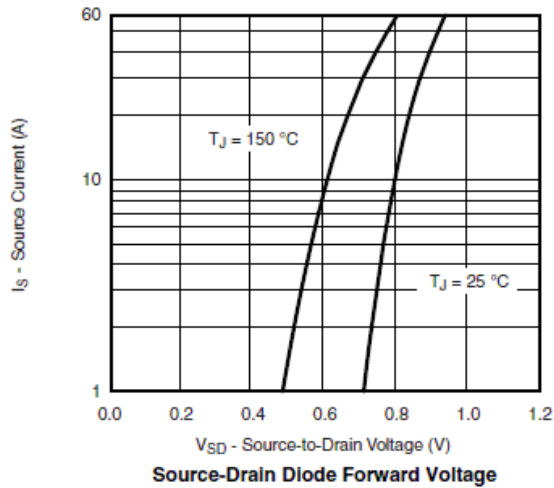



Typical Characteristics

Gate Charge Test Circuit & Waveform

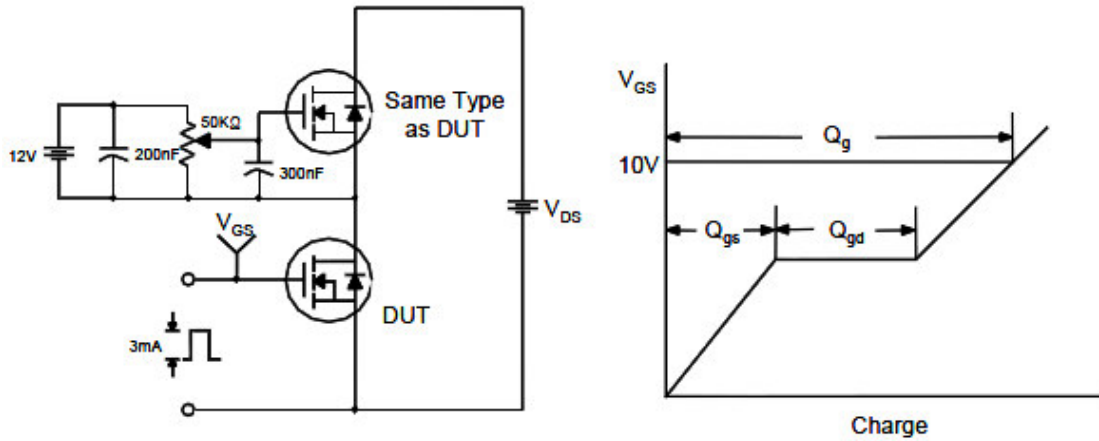

Resistive Switching Test Circuit & Waveforms

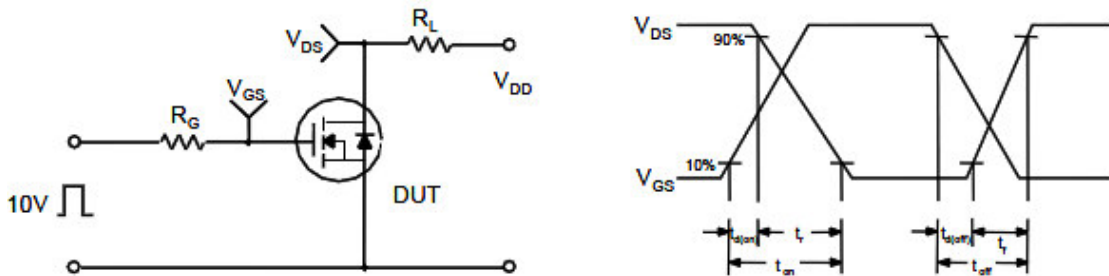

Unclamped Inductive Switching Test Circuit & Waveforms

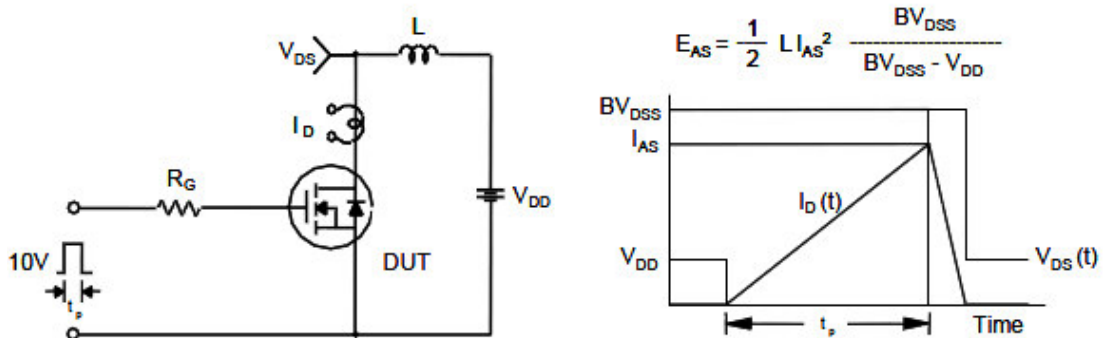



Package Information (SOP-8P)

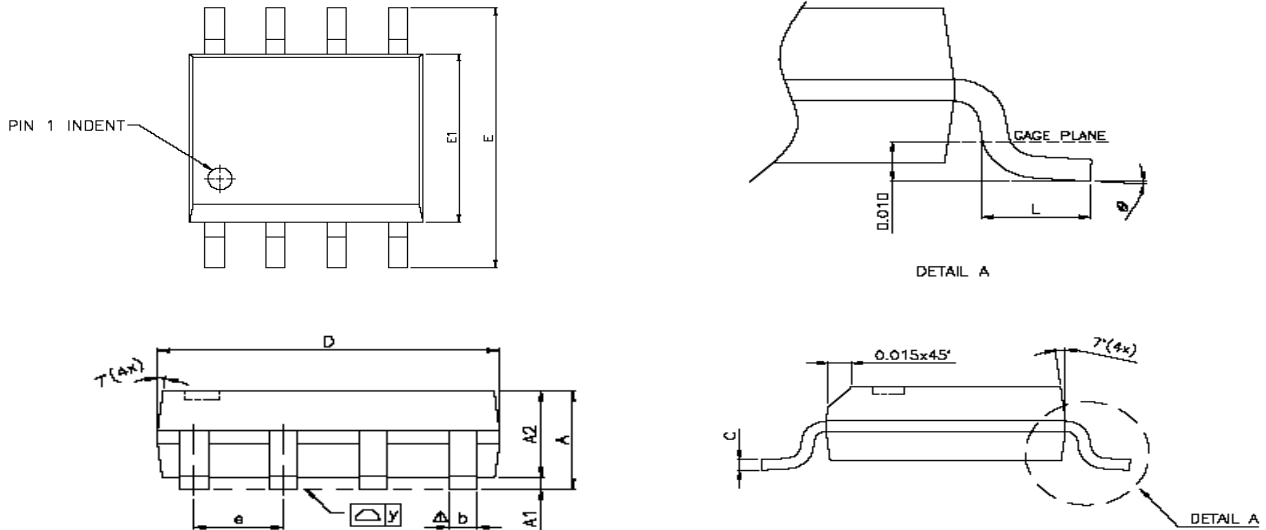

SYMBOLS	DIMENSIONS IN MILLIMETERS			DIMENSIONS IN INCHES		
	MIN	NOM	MAX	MIN	NOM	MAX
A	1.47	1.60	1.73	0.058	0.063	0.068
A1	0.10	—	0.25	0.004	—	0.010
A2	—	1.45	—	—	0.057	—
b	0.33	0.41	0.51	0.013	0.016	0.020
C	0.19	0.20	0.25	0.0075	0.008	0.0098
D	4.80	4.85	4.95	0.189	0.191	0.195
E	5.80	6.00	6.20	0.228	0.236	0.244
E1	3.80	3.90	4.00	0.150	0.154	0.157
e	—	1.27	—	—	0.050	—
L	0.38	0.71	1.27	0.015	0.028	0.050
Δ y	—	—	0.076	—	—	0.003
\varnothing	0°	—	8°	0°	—	8°

©2010 Alfa-MOS Technology Corp.
 2F, No.80, Sec.1, Cheng Kung Rd., Nan Kang Dist., Taipei City 115, Taiwan (R.O.C.)
 Tel : 886 2) 2651 3928
 Fax : 886 2) 2786 8483
 ©http://www.alfa-mos.com