

General Description

AFN6804S, N-Channel enhancement mode MOSFET, uses Advanced Trench Technology to provide excellent $R_{DS(ON)}$, low gate charge. These devices are particularly suited for low voltage power management, and low in-line power loss are needed in commercial industrial surface mount applications.

Features

- 100V/20A, $R_{DS(ON)}=6.8m\Omega@V_{GS}=10V$
- 100V/15A, $R_{DS(ON)}=9.8m\Omega@V_{GS}=4.5V$
- Super high density cell design for extremely low $R_{DS(ON)}$
- DFN5X6-8L package design

Pin Description (DFN5X6-8L)

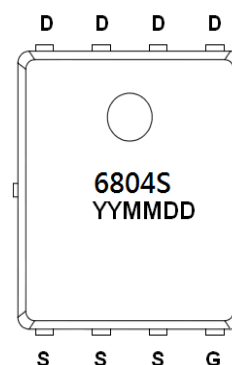
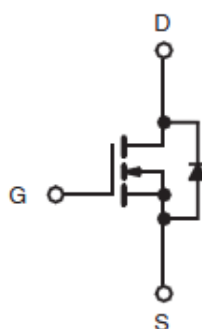
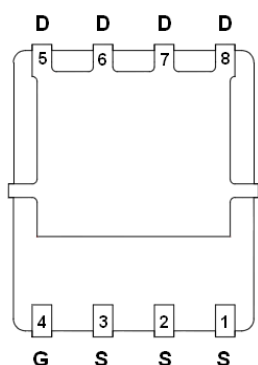

Application

- Networking / Telecom / Server
- LED Lighting Applications
- Quick Charger Applications
- DC-DC Primary Side Switch

Pin Define

Pin	Symbol	Description
1~3	S	Source
4	G	Gate
5~8	D	Drain

Ordering Information

Part Ordering No.	Part Marking	Package	Unit	Quantity
AFN6804SFN568RG	6804S	DFN5X6-8L	Tape & Reel	2500 EA

- ※ 6804S : Parts Code
- ※ YYMMDD : Date Code
- ※ AFN6804SFN568RG : 13" Tape & Reel ; Pb- Free ; Halogen- Free



Absolute Maximum Ratings

(T_A=25°C Unless otherwise noted)

Parameter	Symbol	Typical	Unit
Drain-Source Voltage	V _{DSS}	100	V
Gate –Source Voltage	V _{GSS}	±20	V
Continuous Drain Current(T _J =150°C)	I _{DSM}	T _A =25°C	20
		T _A =70°C	16
Pulsed Drain Current	I _{DM}	120	A
Continuous Source Current(Diode Conduction)	I _S	5.6	
Single Pulse Avalanche Current	E _{AS}	L=0.1mH	35
			60
Power Dissipation	P _D	T _A =25°C	6.25
		T _A =75°C	4.0
Operating Junction Temperature	T _J	150	°C
Storage Temperature Range	T _{STG}	-55/150	°C
Thermal Resistance-Junction to Ambient	R _{θJA}	15	°C/W
Maximum Junction-to-Case (Drain)	R _{θJA}	0.9	

Electrical Characteristics

(T_A=25°C Unless otherwise noted)

Parameter	Symbol	Conditions	Min.	Typ	Max.	Unit
Static						
Drain-Source Breakdown Voltage	V _{(BR)DSS}	V _{GS} =0V, I _D =250uA	100			V
Gate Threshold Voltage	V _{GS(th)}	V _{DS} =V _{GS} , I _D =250uA	1.0	1.6	2.5	
Gate Leakage Current	I _{GSS}	V _{DS} =0V, V _{GS} =±20V			±100	nA
Zero Gate Voltage Drain Current	I _{DSS}	V _{DS} =80V, V _{GS} =0V			1	uA
		V _{DS} =80V, V _{GS} =0V T _J =85°C			10	
On-State Drain Current	I _{D(on)}	V _{DS} ≥ 5V, V _{GS} =10V	30			A
Drain-Source On-Resistance	R _{DS(on)}	V _{GS} =10V, I _D =20A		6.2	6.8	mΩ
		V _{GS} =4.5V, I _D =15A		8.9	9.8	
Forward Transconductance	g _{FS}	V _{DS} =10V, I _D =20A		72		S
Diode Forward Voltage	V _{SD}	I _S =5A, V _{GS} =0V		0.8	1.3	V
Dynamic						
Total Gate Charge	Q _g	V _{DS} =50V, V _{GS} =4.5V I _D ≧20A		23	45	nC
Gate-Source Charge	Q _{gs}			8		
Gate-Drain Charge	Q _{gd}			10		
Input Capacitance	C _{iss}	V _{DS} =50V, V _{GS} =0V f=1MHz		2450		pF
Output Capacitance	C _{oss}			1400		
Reverse Transfer Capacitance	C _{rss}			80		
Turn-On Time	t _{d(on)}	V _{DD} =50V, R _L =2.5Ω I _D ≧20A, V _{GEN} =10V R _G =1Ω		10	20	ns
	t _r			10	20	
Turn-Off Time	t _{d(off)}			40	80	
	t _f		10	20		



Typical Characteristics

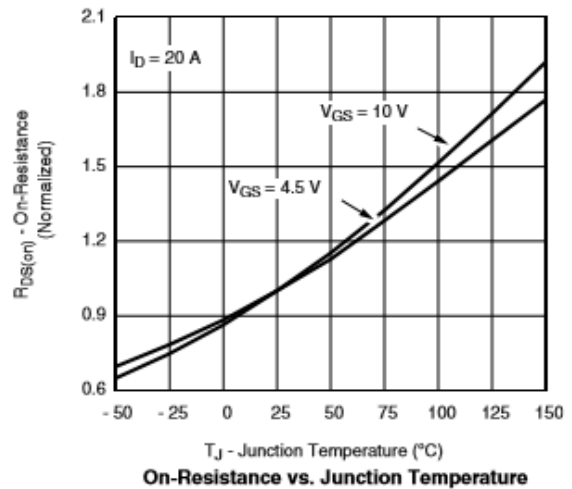
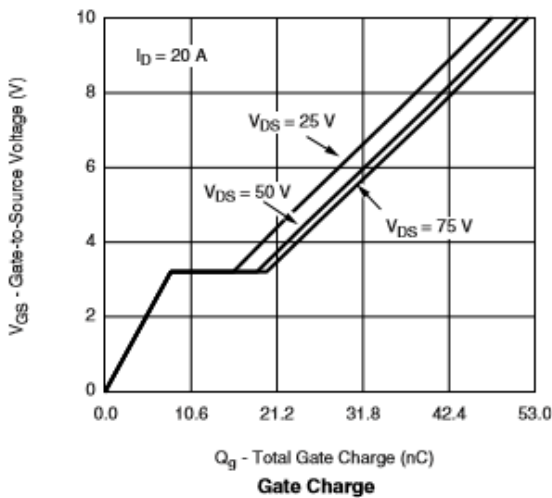
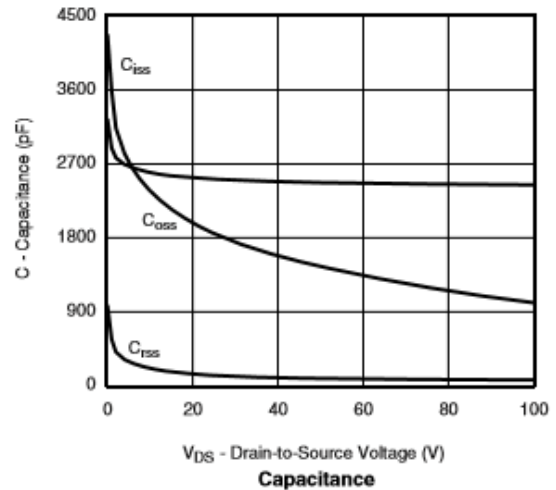
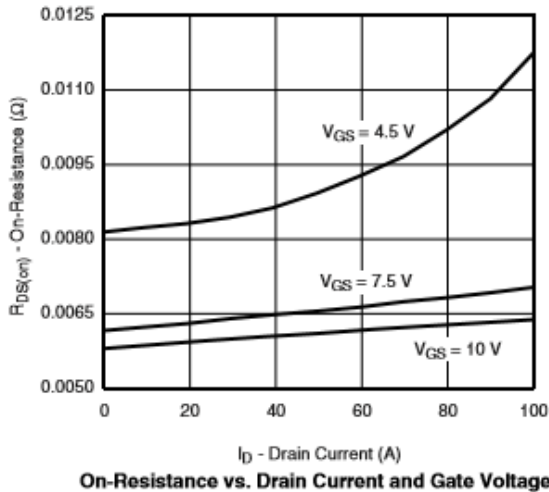
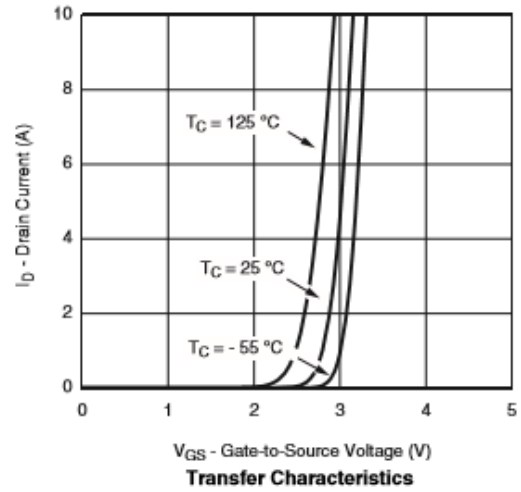
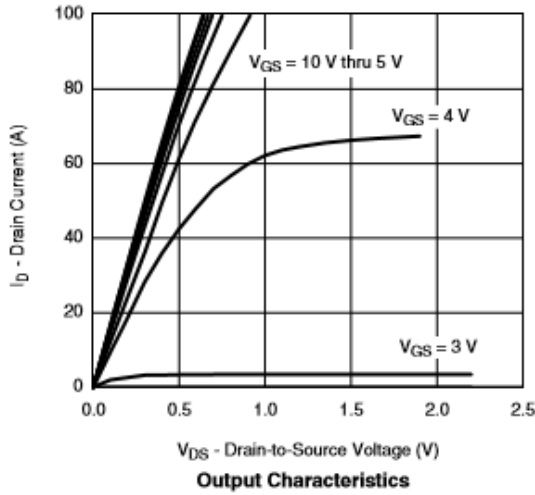



Typical Characteristics

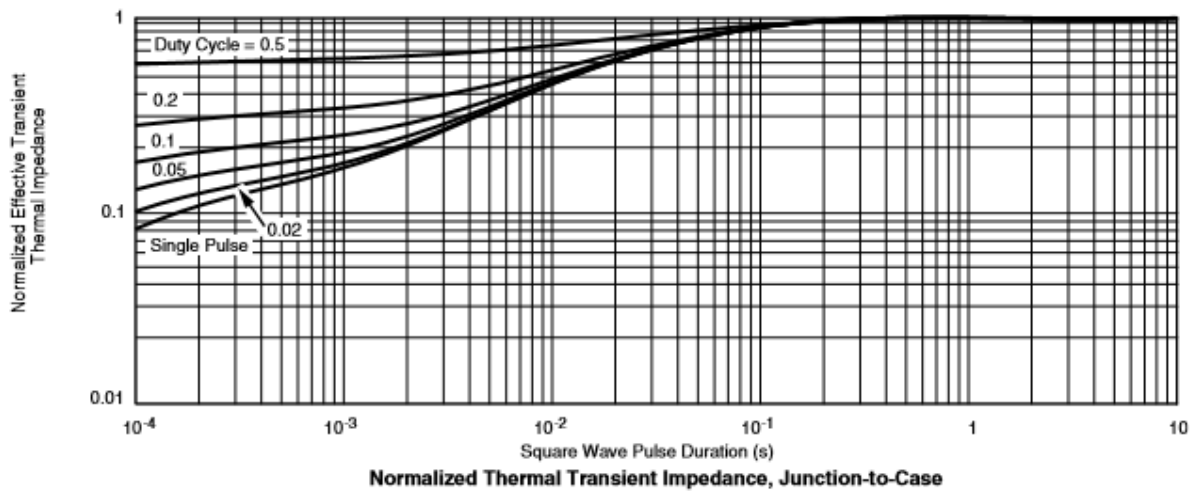
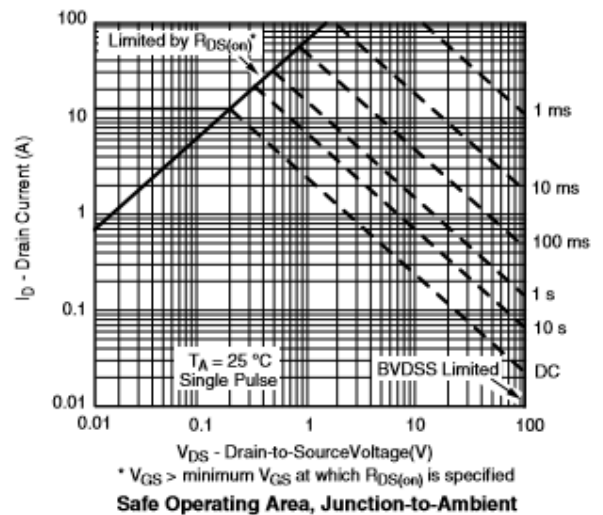
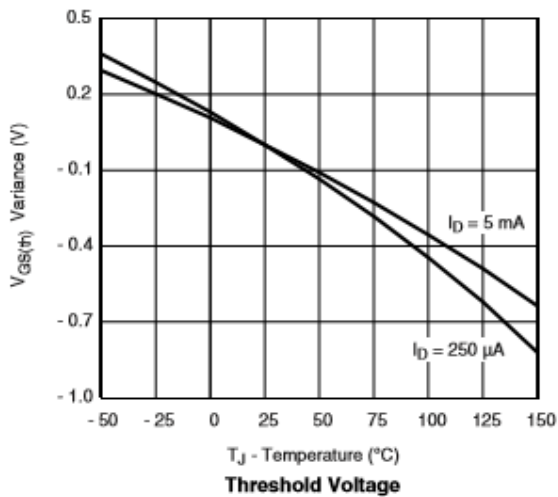
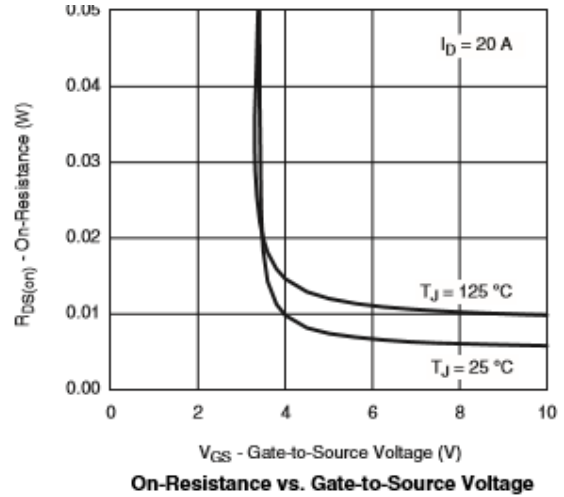
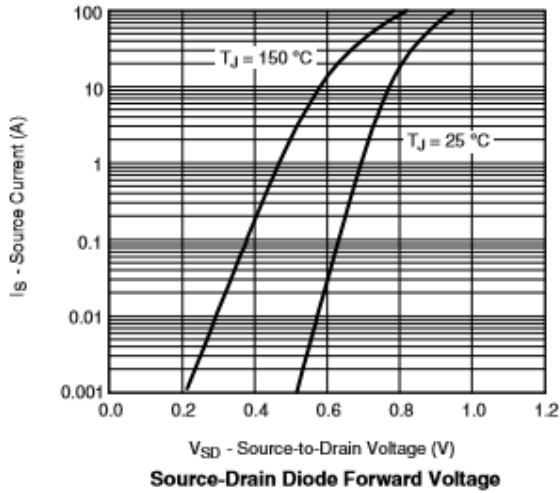



Typical Characteristics

Gate Charge Test Circuit & Waveform

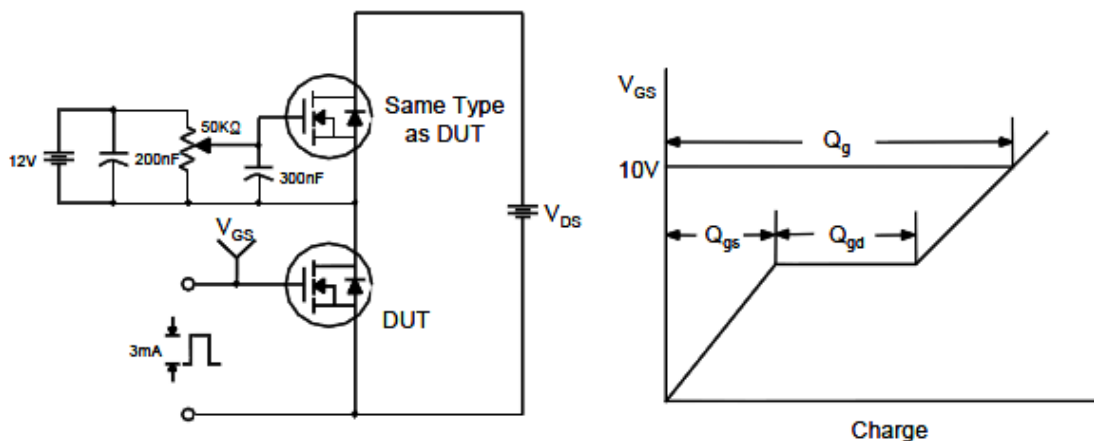

Resistive Switching Test Circuit & Waveforms

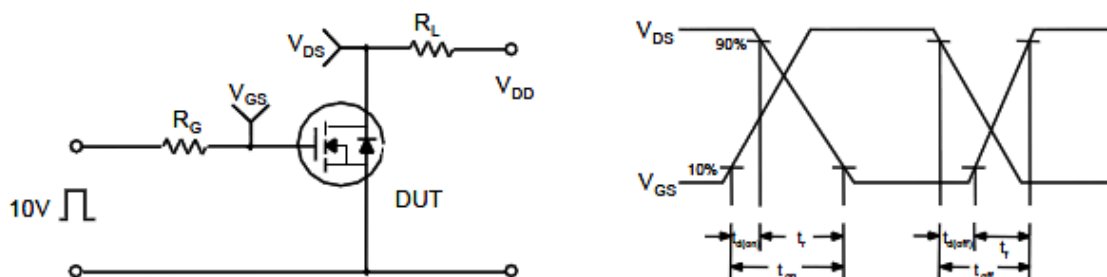

Unclamped Inductive Switching Test Circuit & Waveforms

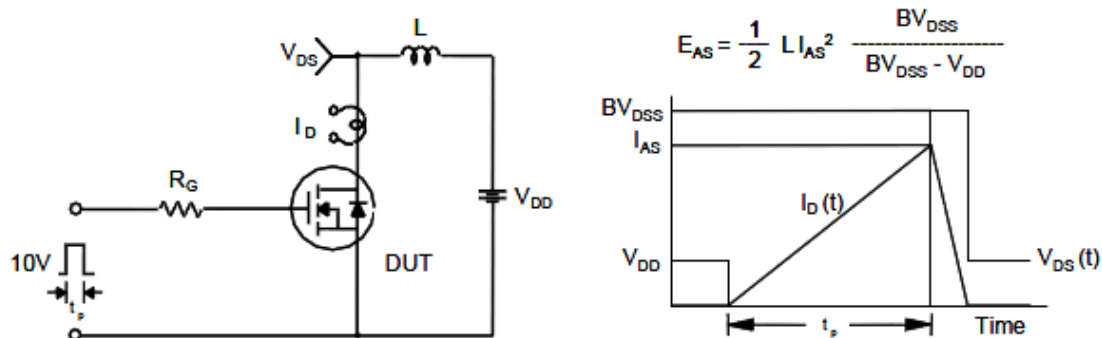



Package Information (DFN5X6-8L)

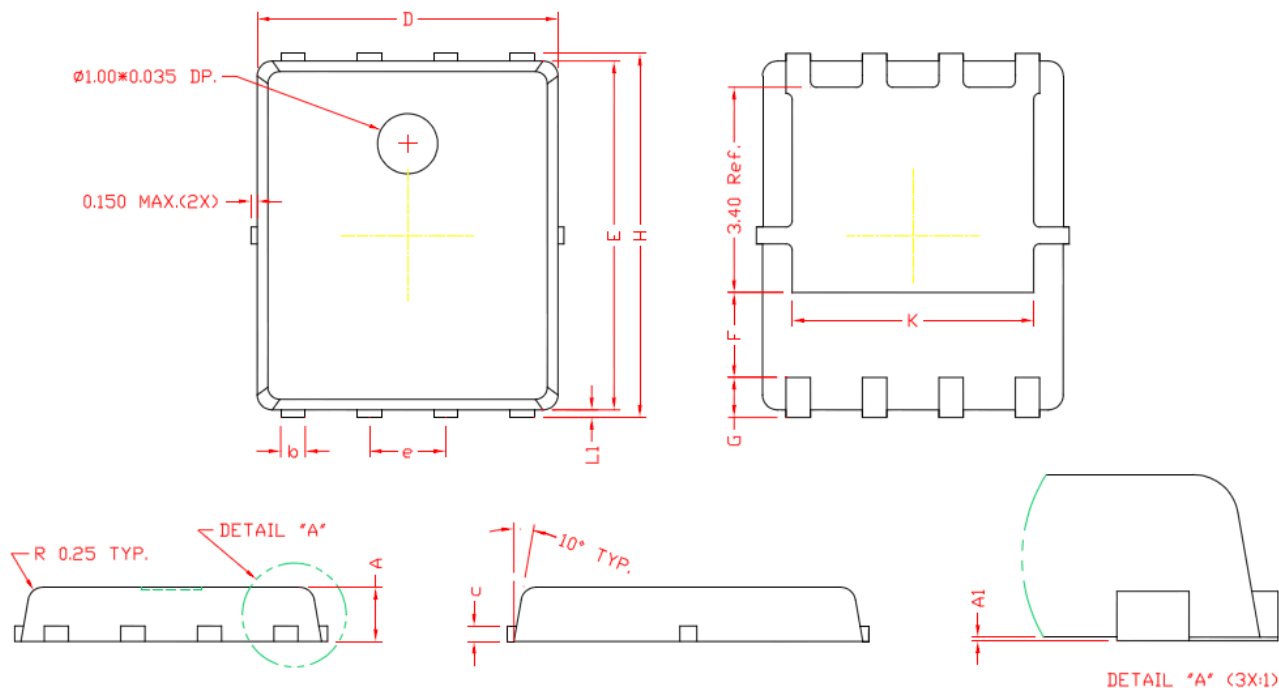

DIMENSIONS

REF.	Millimeters		REF.	Millimeters	
	Min.	Max.		Min.	Max.
A	0.80	1.00	E	5.70	5.90
A1	0.00	0.05	e	1.27 BSC.	
b	0.35	0.49	H	5.95	6.20
c	0.254 Ref.		L1	0.10	0.18
D	4.90	5.10	G	0.60 Ref.	
F	1.40 Ref.		K	4.00 Ref.	

©2010 Alfa-MOS Technology Corp.
 2F, No.80, Sec.1, Cheng Kung Rd., Nan Kang Dist., Taipei City 115, Taiwan (R.O.C.)
 Tel : 886 2) 2651 3928
 Fax : 886 2) 2786 8483
 ©http://www.alfa-mos.com