



General Description

AFP1023, P-Channel enhancement mode MOSFET, uses Advanced Trench Technology to provide excellent $R_{DS(ON)}$, low gate charge.

These devices are particularly suited for low voltage power management, such as smart phone and notebook computer, and low in-line power loss are needed in commercial industrial surface mount applications.

Features

- -20V/-0.45A, $R_{DS(ON)} = 620 \text{ m}\Omega @ V_{GS} = -4.5\text{V}$
- -20V/-0.35A, $R_{DS(ON)} = 860 \text{ m}\Omega @ V_{GS} = -2.5\text{V}$
- -20V/-0.25A, $R_{DS(ON)} = 1450 \text{ m}\Omega @ V_{GS} = -1.8\text{V}$
- Low Offset (Error) Voltage
- Low-Voltage Operation
- High-Speed Circuits
- Low Battery Voltage Operation
- SOT-563 package design

Pin Description (SOT-563)

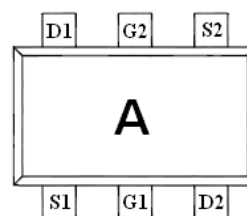
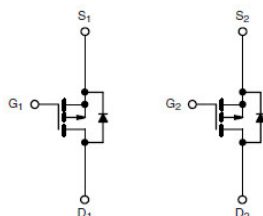
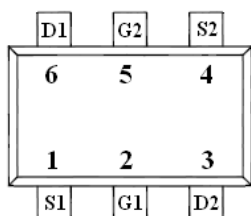

Application

- Drivers: Relays, Solenoids, Lamps, Hammers, Displays, Memories
- Battery Operated Systems
- Power Supply Converter Circuits
- Load/Power Switching Smart Phones, Pagers

Pin Define

Pin	Symbol	Description
1	S1	Source 1
2	G1	Gate 1
3	D2	Drain 2
4	S2	Source 2
5	G2	Gate 2
6	D1	Drain1

Ordering Information

Part Ordering No.	Part Marking	Package	Unit	Quantity
AFP1023S56RG	A	SOT-563	Tape & Reel	3000 EA

※ AFP1023S56RG : 7" Tape & Reel ; Pb- Free ; Halogen- Free



Absolute Maximum Ratings

(T_A=25°C Unless otherwise noted)

Parameter	Symbol	Typical	Unit
Drain-Source Voltage	V _{DSS}	-20	V
Gate –Source Voltage	V _{GSS}	±12	V
Continuous Drain Current(T _J =150°C)	I _D	T _A =25°C	-0.45
		T _A =70°C	-0.25
Pulsed Drain Current	I _{DM}	-1.0	A
Continuous Source Current(Diode Conduction)	I _S	-0.3	A
Power Dissipation	P _D	T _A =25°C	0.27
		T _A =70°C	0.16
Operating Junction Temperature	T _J	-55/150	°C
Storage Temperature Range	T _{STG}	-55/150	°C

Electrical Characteristics

(T_A=25°C Unless otherwise noted)

Parameter	Symbol	Conditions	Min.	Typ	Max.	Unit
Static						
Drain-Source Breakdown Voltage	V _{(BR)DSS}	V _{GS} =0V, I _D =-250uA	-20			V
Gate Threshold Voltage	V _{GS(th)}	V _{DS} =V _{GS} , I _D =-250uA	-0.4		-1.0	
Gate Leakage Current	I _{GSS}	V _{DS} =0V, V _{GS} =±12V			±100	nA
Zero Gate Voltage Drain Current	I _{DSS}	V _{DS} =-20V, V _{GS} =0V			-1	uA
		V _{DS} =-20V, V _{GS} =0V T _J =85°C			-5	
On-State Drain Current	I _{D(on)}	V _{DS} ≥ 5V, V _{GS} =4.5V	0.7			A
Drain-Source On-Resistance	R _{DS(on)}	V _{GS} =-4.5V, I _D =-0.45A		500	620	mΩ
		V _{GS} =-2.5V, I _D =-0.35A		700	860	
		V _{GS} =-1.8V, I _D =-0.25A		1000	1450	
Forward Transconductance	g _{FS}	V _{DS} =-10V, I _D =-0.4A		1		S
Diode Forward Voltage	V _{SD}	I _S =-0.15A, V _{GS} =0V		0.65	1.2	V
Dynamic						
Input Capacitance	C _{iss}	V _{DS} =-10V, V _{GS} =0V f=1MHz		70	100	pF
Output Capacitance	C _{oss}			20		
Reverse Transfer Capacitance	C _{rss}			10		
Total Gate Charge	Q _g	V _{DS} =-10V, V _{GS} =-4.5V I _D ≡-0.25A		1.0	1.3	nC
Gate-Source Charge	Q _{gs}			0.1		
Gate-Drain Charge	Q _{gd}			0.3		
Turn-On Time	t _{d(on)}	V _{DD} =-10V, R _L =30Ω I _D ≡-0.2A, V _{GEN} =-4.5V R _G =10Ω		10	15	ns
	t _r			10	15	
Turn-Off Time	t _{d(off)}			40	60	
	t _f			30	50	



Typical Characteristics

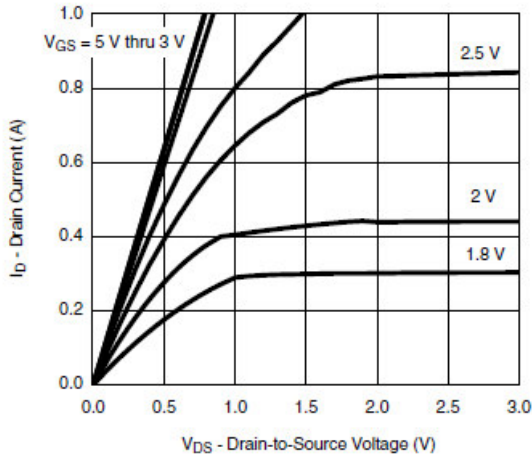

Output Characteristics

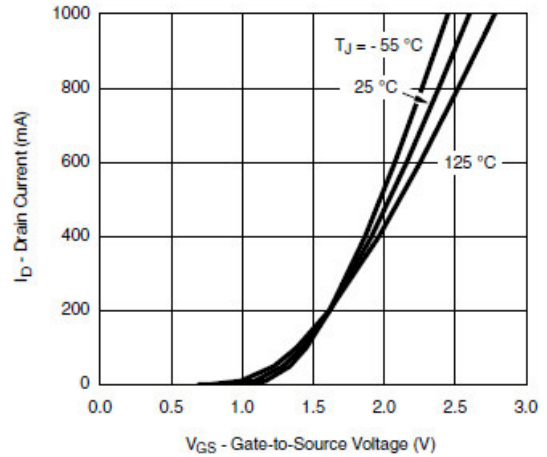

Transfer Characteristics

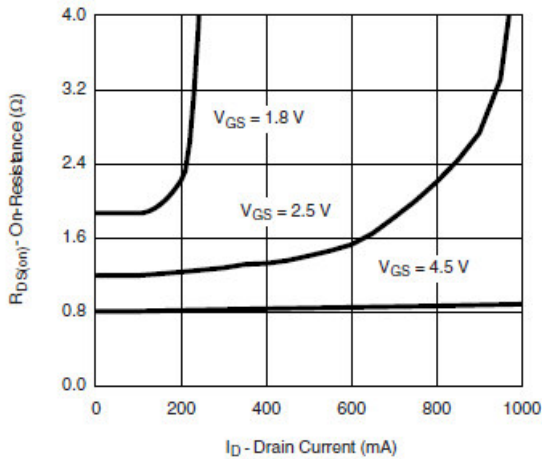

On-Resistance vs. Drain Current

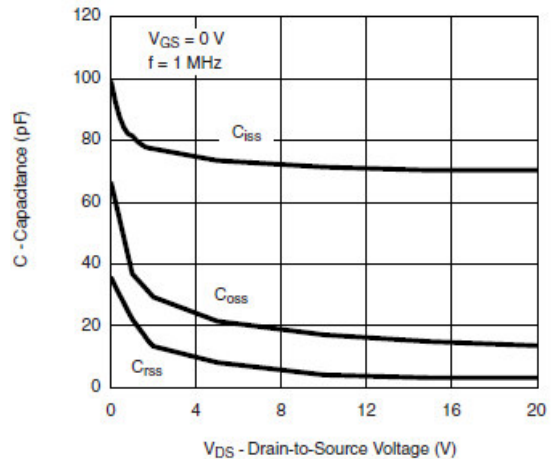

Capacitance

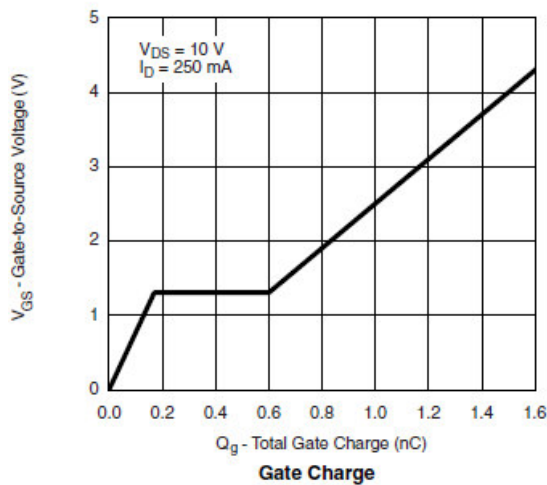

Gate Charge

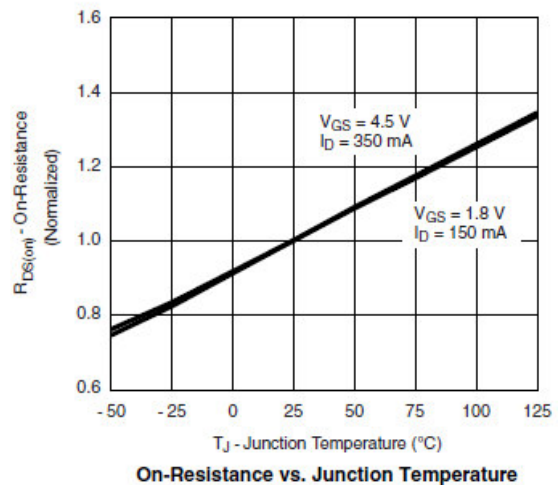

On-Resistance vs. Junction Temperature



Typical Characteristics

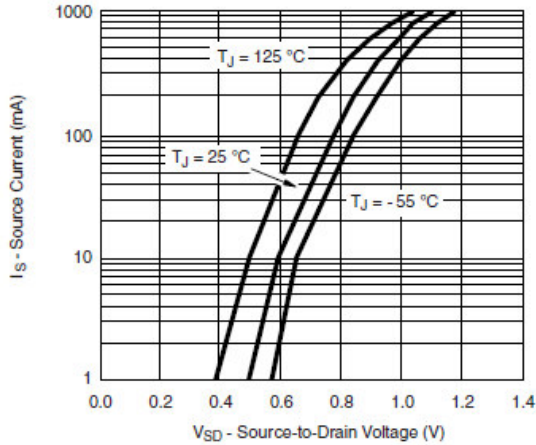

Source-Drain Diode Forward Voltage

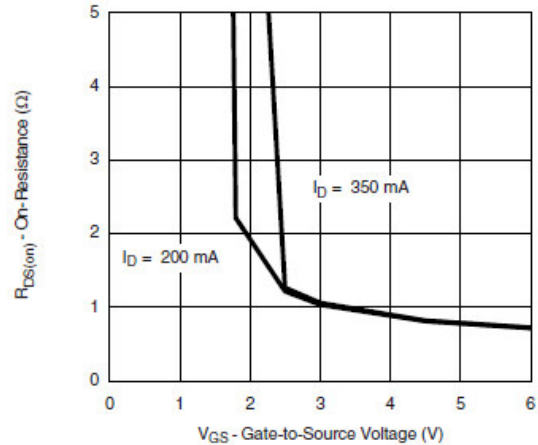

On-Resistance vs. Gate-to-Source Voltage

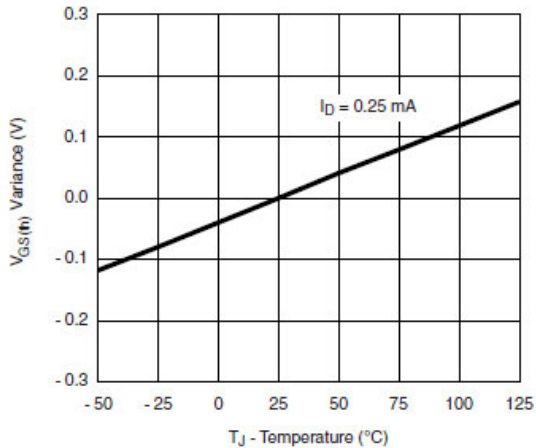

Threshold Voltage Variance vs. Temperature

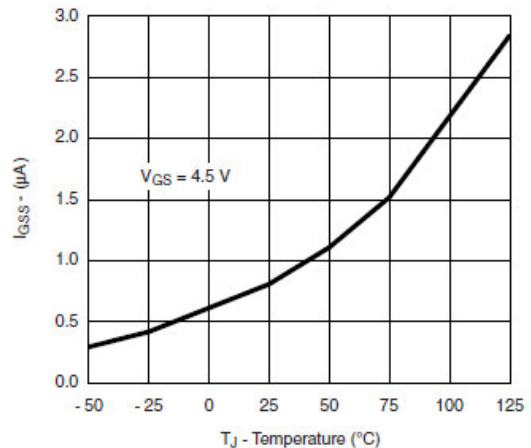

I_{GSS} vs. Temperature

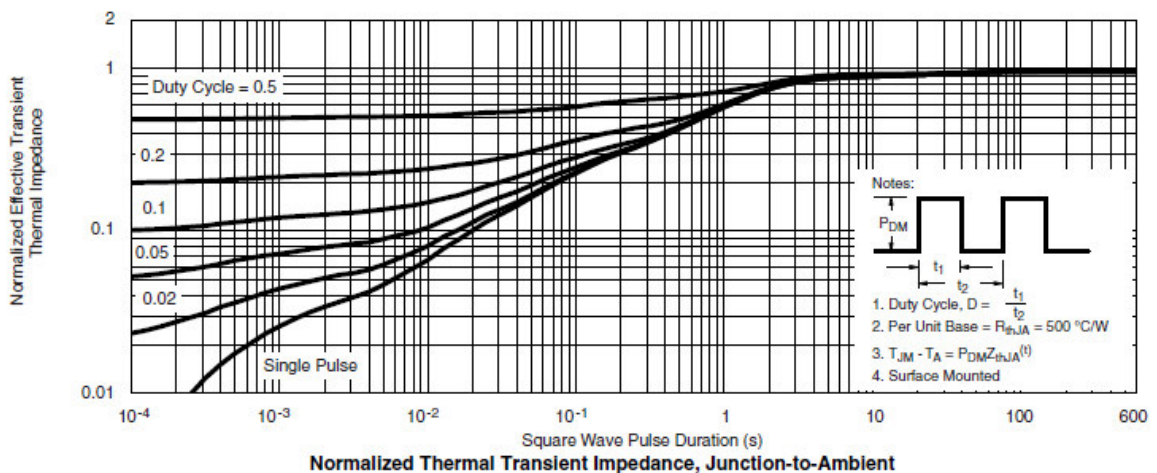



Typical Characteristics

Gate Charge Test Circuit & Waveform

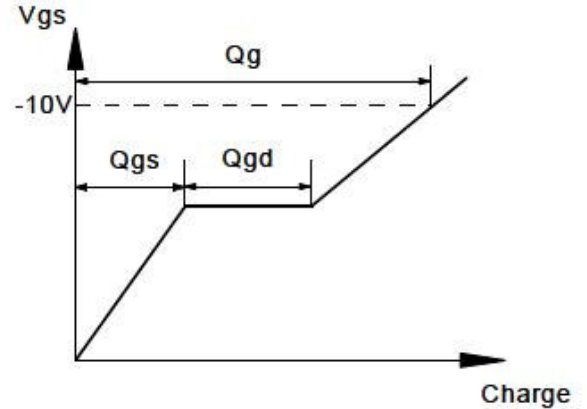
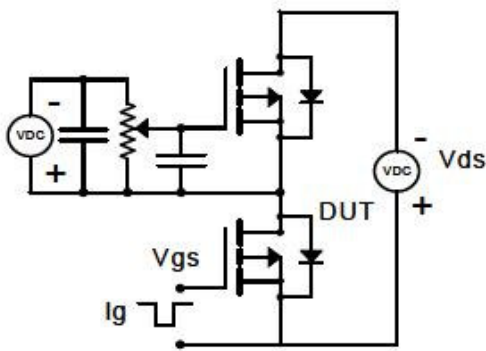

Resistive Switching Test Circuit & Waveforms

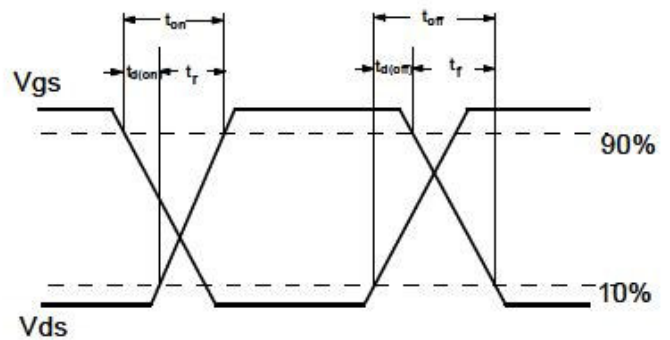
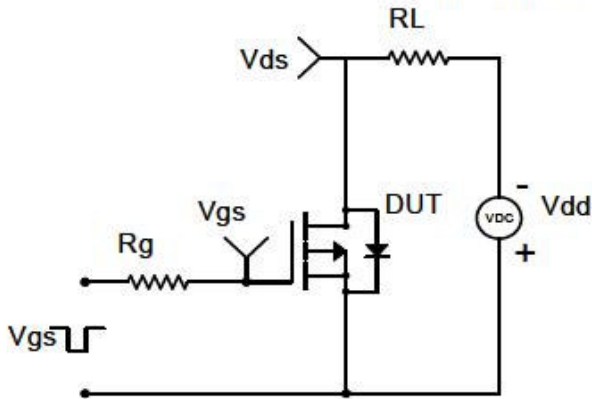

Diode Recovery Test Circuit & Waveforms

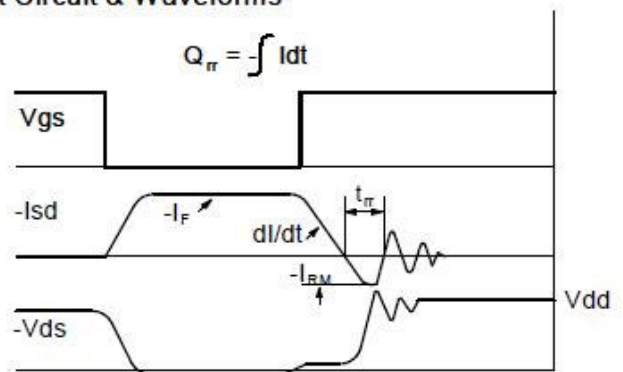
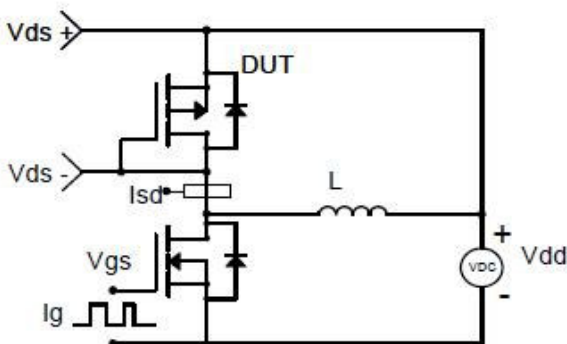



Package Information (SOT-563)

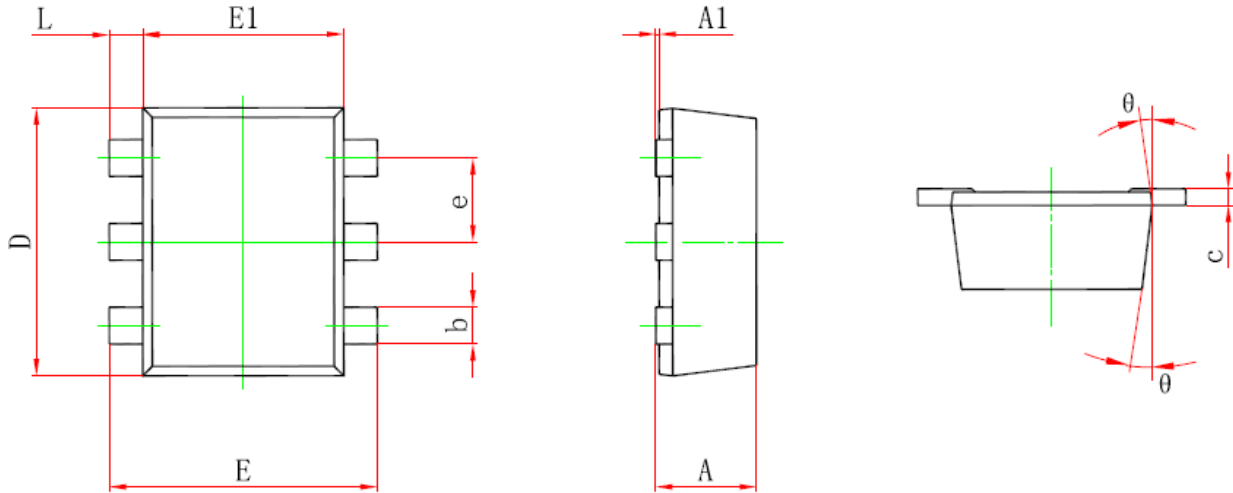

Symbol	Dimensions In Millimeters		Dimensions In Inches	
	Min.	Max.	Min.	Max.
A	0.525	0.600	0.021	0.024
A1	0.000	0.050	0.000	0.002
e	0.450	0.550	0.018	0.022
c	0.090	0.160	0.004	0.006
D	1.500	1.700	0.059	0.067
b	0.170	0.270	0.007	0.011
E1	1.100	1.300	0.043	0.051
E	1.500	1.700	0.059	0.067
L	0.100	0.300	0.004	0.012
θ	7 °REF.		7 °REF.	

©2010 Alfa-MOS Technology Corp.
 2F, No.80, Sec.1, Cheng Kung Rd., Nan Kang Dist., Taipei City 115, Taiwan (R.O.C.)
 Tel : 886 2) 2651 3928
 Fax : 886 2) 2786 8483
 ©http://www.alfa-mos.com