



General Description

AFP2913W, P-Channel enhancement mode MOSFET, uses Advanced Trench Technology to provide excellent $R_{DS(ON)}$, low gate charge. These devices are particularly suited for low voltage power management, such as smart phone and notebook computer and other battery powered circuits, and low in-line power loss are needed in commercial industrial surface mount applications.

Features

- -25V/-4.5A, $R_{DS(ON)}=120m\Omega@V_{GS}=-10V$
- -25V/-3.8A, $R_{DS(ON)}=155m\Omega@V_{GS}=-4.5V$
- Super high density cell design for extremely low $R_{DS(ON)}$
- Exceptional on-resistance and maximum DC current capability
- DFN2X2-6L package design

Pin Description (DFN2X2-6L)

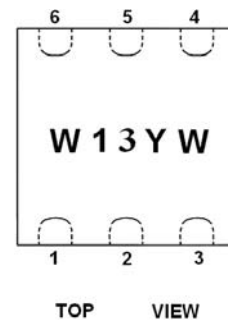
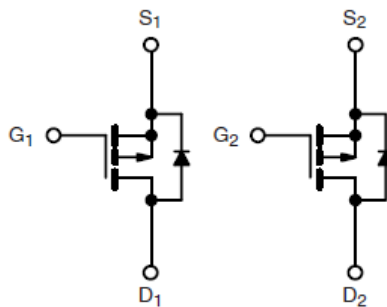
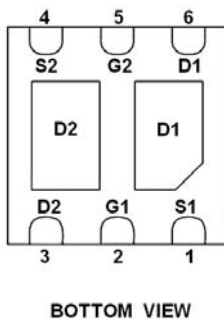

Application

- Load Switch
- Portable Equipment
- Battery Powered System

Pin Define

Pin	Symbol	Description
1	S1	Source1
2	G1	Gate1
3	D2	Drain2
4	S2	Source2
5	G2	Gate2
6	D1	Drain1

Ordering Information

Part Ordering No.	Part Marking	Package	Unit	Quantity
AFP2913WFN226RG	W13YW	DFN2X2-6L	Tape & Reel	4000 EA

- ※ W13 parts code
- ※ Y year code
- ※ W week code (A ~ Z = 1 ~ 26 / a ~ z = 27 ~ 52)
- ※ AFP2913WFN226RG : 7" Tape & Reel ; Pb- Free ; Halogen -Free



Absolute Maximum Ratings

(T_A=25°C Unless otherwise noted)

Parameter	Symbol	Typical	Unit
Drain-Source Voltage	V _{DSS}	-25	V
Gate –Source Voltage	V _{GSS}	±20	V
Continuous Drain Current(T _J =150°C)	I _D	T _A =25°C	-4.5
		T _A =70°C	-3.8
Pulsed Drain Current	I _{DM}	-12	A
Continuous Source Current(Diode Conduction)	I _S	-1.6	A
Power Dissipation	P _D	T _A =25°C	6.5
		T _A =70°C	4.2
Operating Junction Temperature	T _J	150	°C
Storage Temperature Range	T _{STG}	-55/150	°C
Thermal Resistance-Junction to Ambient	R _{θJA}	120	°C/W

Electrical Characteristics

(T_A=25°C Unless otherwise noted)

Parameter	Symbol	Conditions	Min.	Typ	Max.	Unit
Static						
Drain-Source Breakdown Voltage	V _{(BR)DSS}	V _{GS} =0V, I _D =-250uA	-25			V
Gate Threshold Voltage	V _{GS(th)}	V _{DS} =V _{GS} , I _D =-250uA	-1.0		-2.5	V
Gate Leakage Current	I _{GSS}	V _{DS} =0V, V _{GS} =±12V			±100	nA
Zero Gate Voltage Drain Current	I _{DSS}	V _{DS} =-20V, V _{GS} =0V			-1	uA
		V _{DS} =-20V, V _{GS} =0V T _J =85°C			-30	
On-State Drain Current	I _{D(on)}	V _{DS} ≤ -5V, V _{GS} =-4.5V	-8			A
		V _{DS} ≤ -5V, V _{GS} =-2.5V	-3			
Drain-Source On-Resistance	R _{DS(on)}	V _{GS} =-10V, I _D =-4.5A		108	120	mΩ
		V _{GS} =-4.5V, I _D =-3.8A		142	155	
Forward Transconductance	g _{FS}	V _{DS} =-5V, I _D =-2.8A		6.5		S
Diode Forward Voltage	V _{SD}	I _S =-1.25A, V _{GS} =0V		-0.75	-1.3	V
Dynamic						
Total Gate Charge	Q _g	V _{DS} =-10V, V _{GS} =-4.5V I _D =-3.5A		5	10	nC
Gate-Source Charge	Q _{gs}			0.85		
Gate-Drain Charge	Q _{gd}			1.5		
Input Capacitance	C _{iss}	V _{DS} =-10V, V _{GS} =0V f=1MHz		375		pF
Output Capacitance	C _{oss}			80		
Reverse Transfer Capacitance	C _{rss}			60		
Turn-On Time	t _{d(on)}	V _{DD} =-10V, R _L =2.85Ω I _D =-3.5A, V _{GEN} =-4.5V R _G =1Ω		15	25	ns
	t _r			36	60	
Turn-Off Time	t _{d(off)}			25	50	
	t _f			15	25	

Typical Characteristics

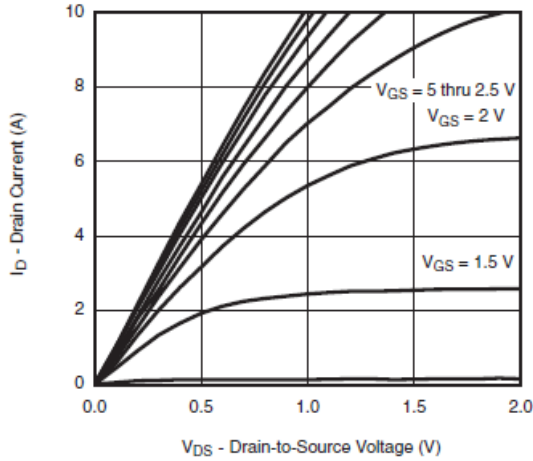

Output Characteristics

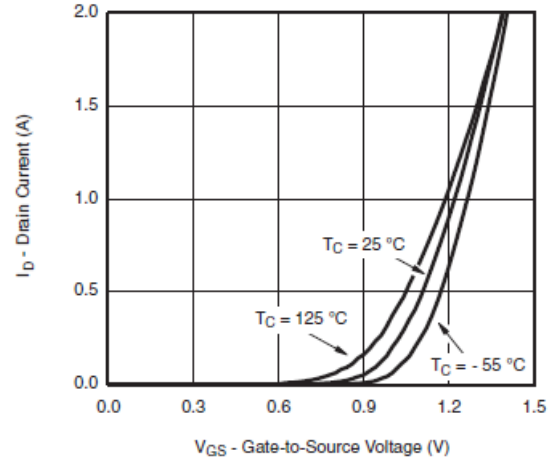

Transfer Characteristics

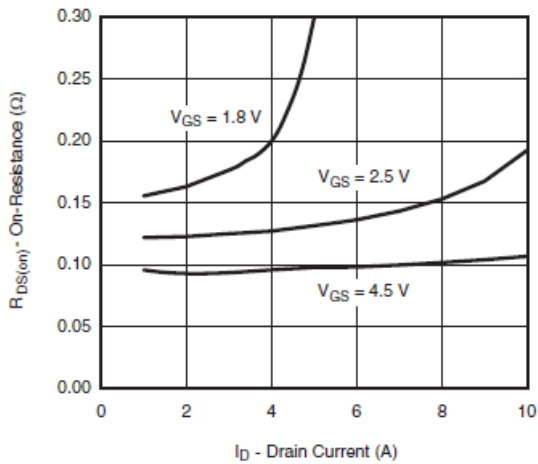

On-Resistance vs. Drain Current and Gate Voltage

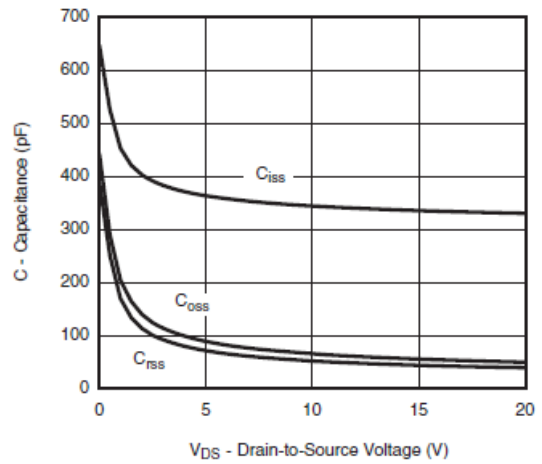

Capacitance

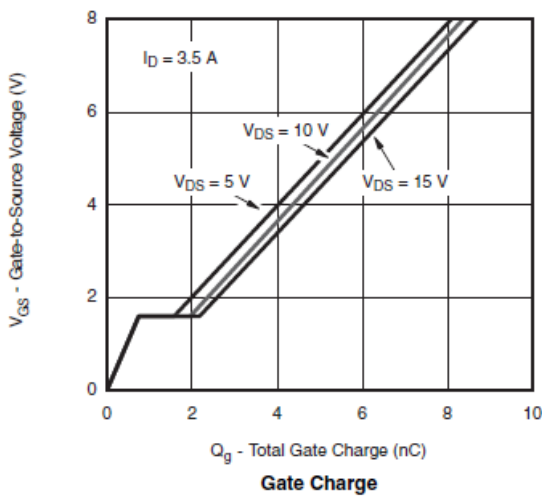

Gate Charge

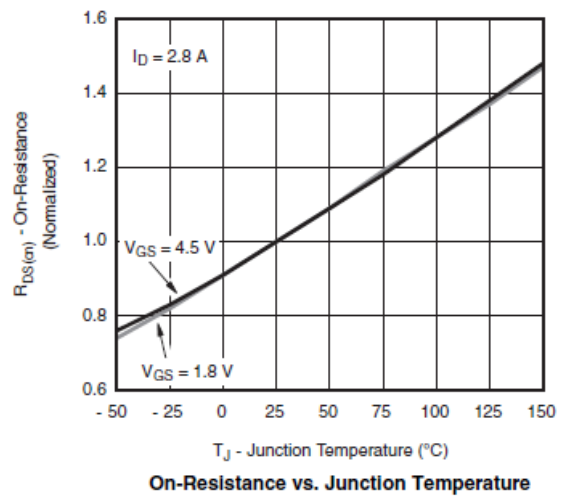

On-Resistance vs. Junction Temperature

Typical Characteristics

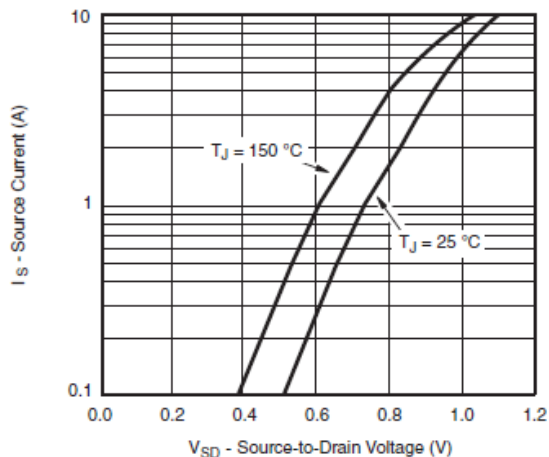

Source-Drain Diode Forward Voltage

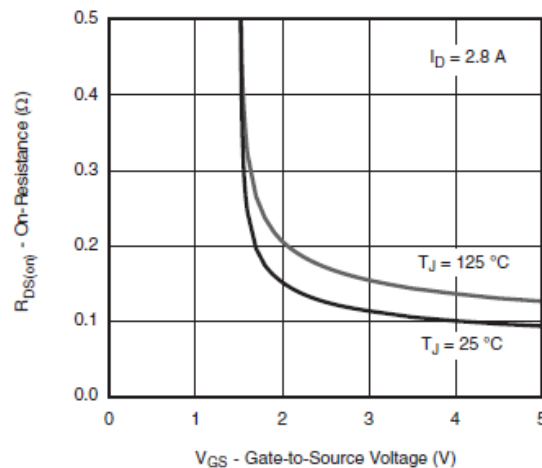

On-Resistance vs. Gate-to-Source Voltage

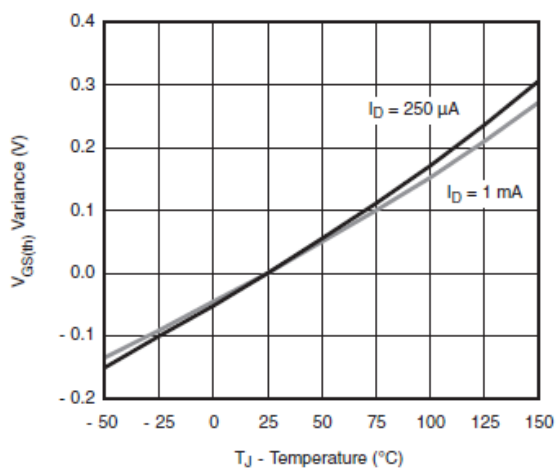

Threshold Voltage

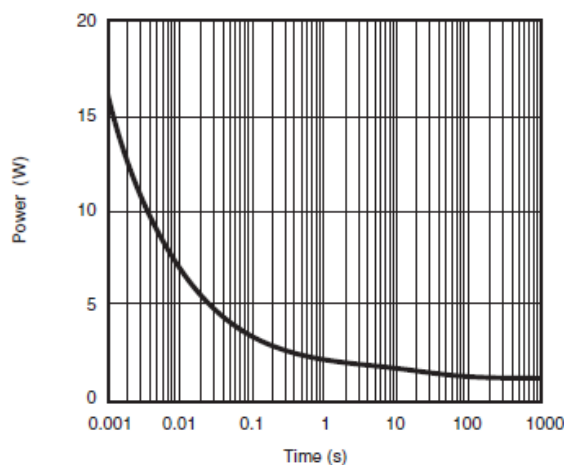

Single Pulse Power, Junction-to-Ambient

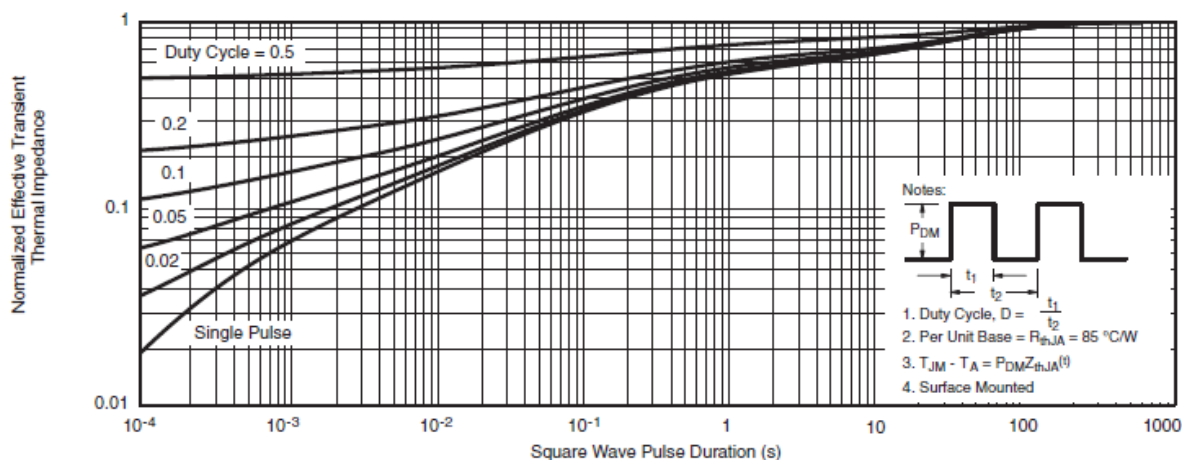

Normalized Thermal Transient Impedance, Junction-to-Ambient

Typical Characteristics



Gate Charge Test Circuit & Waveform

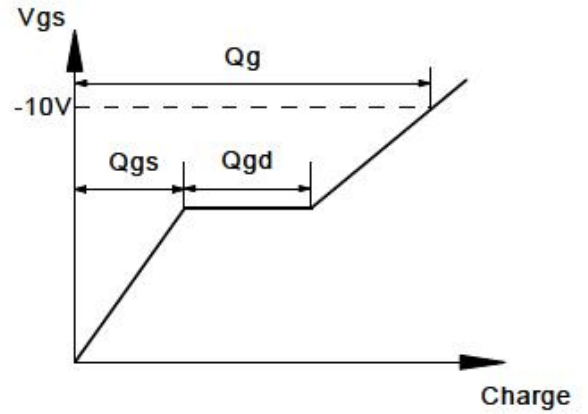
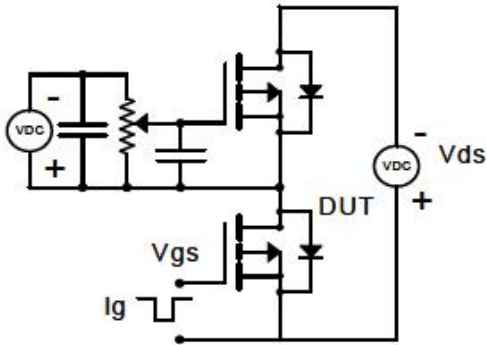

Resistive Switching Test Circuit & Waveforms

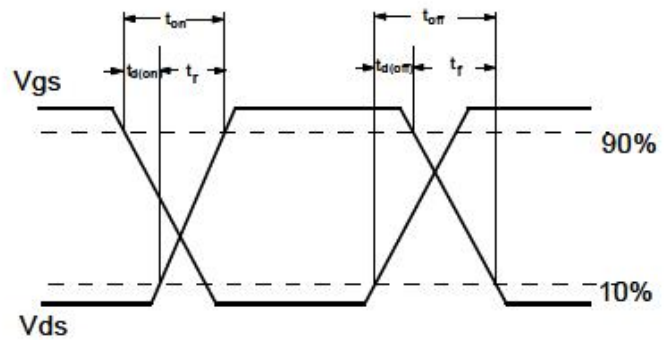
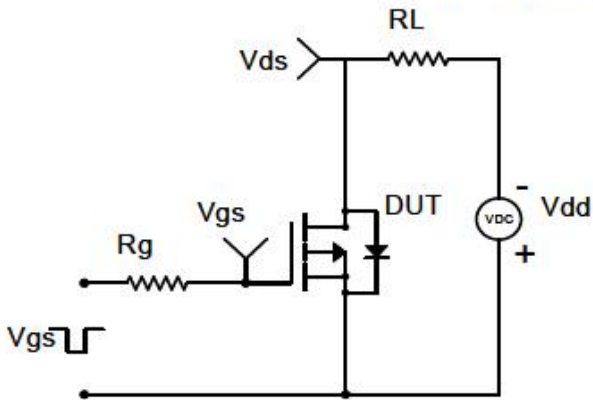

Diode Recovery Test Circuit & Waveforms

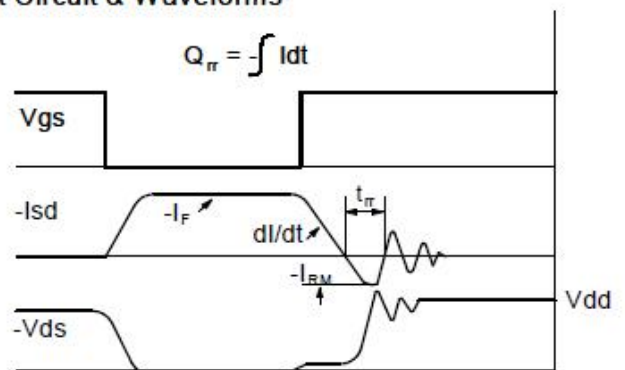
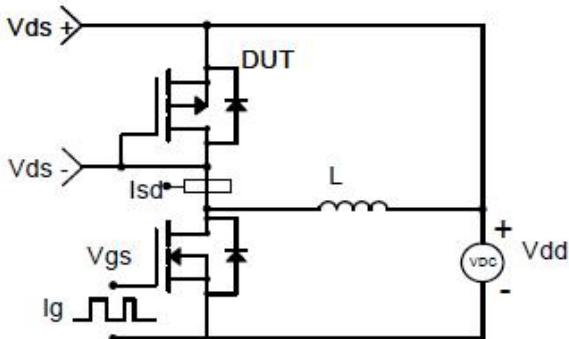

Package Information (DFN2X2-6L)

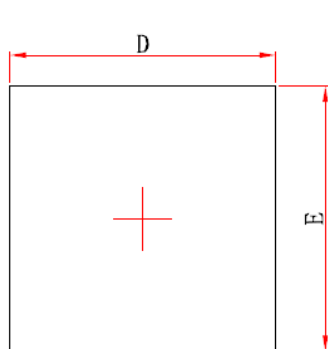

Top View

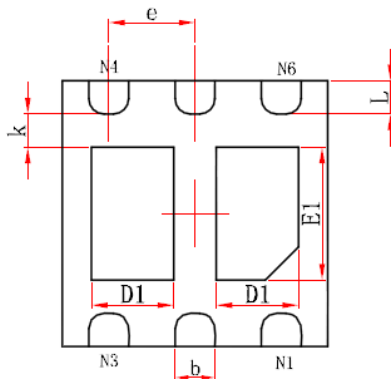

Bottom View

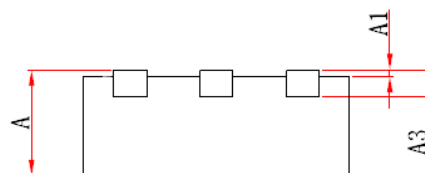

Side View

Symbol	Dimensions In Millimeters		Dimensions In Inches	
	Min.	Max.	Min.	Max.
A	0.700	0.800	0.028	0.031
A1	0.000	0.050	0.000	0.002
A3	0.203REF.		0.008REF.	
D	1.924	2.076	0.076	0.082
E	2.924	3.076	0.115	0.121
D1	1.400	1.600	0.055	0.063
E1	1.400	1.600	0.055	0.063
k	0.200MIN.		0.008MIN.	
b	0.200	0.300	0.008	0.012
e	0.500TYP.		0.020TYP.	
L	0.224	0.376	0.009	0.015

©2010 Alfa-MOS Technology Corp.
2F, No.80, Sec.1, Cheng Kung Rd., Nan Kang Dist., Taipei City 115, Taiwan (R.O.C.)
Tel : 886 2) 2651 3928
Fax : 886 2) 2786 8483
©http://www.alfa-mos.com