



General Description

AFP3403A, P-Channel enhancement mode MOSFET, uses Advanced Trench Technology to provide excellent $R_{DS(ON)}$, low gate charge.

These devices are particularly suited for low voltage power management, such as smart phone and notebook computer and other battery powered circuits, and low in-line power loss are needed in commercial industrial surface mount applications.

Features

- -30V/-2.6A, $R_{DS(ON)}=130m\Omega@V_{GS}=-10V$
- -30V/-2.2A, $R_{DS(ON)}=160m\Omega@V_{GS}=-4.5V$
- -30V/-1.2A, $R_{DS(ON)}=270m\Omega@V_{GS}=-2.5V$
- Super high density cell design for extremely low $R_{DS(ON)}$
- Exceptional on-resistance and maximum DC current capability
- SOT-23 package design

Pin Description (SOT-23)

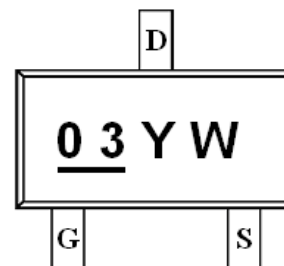
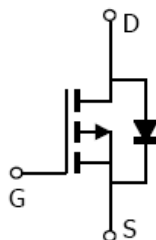
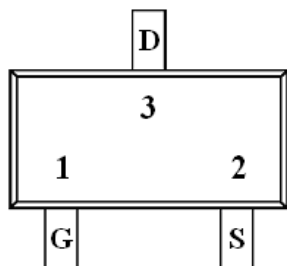

Application

- Power Management in Note book
- Portable Equipment
- Battery Powered System
- Net Working System

Pin Define

Pin	Symbol	Description
1	G	Gate
2	S	Source
3	D	Drain

Ordering Information

Part Ordering No.	Part Marking	Package	Unit	Quantity
AFP3403AS23RG	03YW	SOT-23	Tape & Reel	3000 EA

- ※ 03 parts code
- ※ Y year code (0 ~ 9)
- ※ W week code (A ~ Z = 1 ~ 26 / a ~ z = 27 ~ 52)
- ※ AFP3403AS23RG : 7" Tape & Reel ; Pb- Free ; Halogen- Free



Absolute Maximum Ratings

($T_A=25^{\circ}\text{C}$ Unless otherwise noted)

Parameter	Symbol	Typical	Unit
Drain-Source Voltage	V_{DSS}	-30	V
Gate -Source Voltage	V_{GSS}	± 12	V
Continuous Drain Current($T_J=150^{\circ}\text{C}$)	I_D	$T_A=25^{\circ}\text{C}$	-3.0
		$T_A=70^{\circ}\text{C}$	-1.2
Pulsed Drain Current	I_{DM}	-10	A
Continuous Source Current(Diode Conduction)	I_S	-1.6	A
Power Dissipation	P_D	$T_A=25^{\circ}\text{C}$	1.25
		$T_A=70^{\circ}\text{C}$	0.8
Operating Junction Temperature	T_J	150	$^{\circ}\text{C}$
Storage Temperature Range	T_{STG}	-55/150	$^{\circ}\text{C}$
Thermal Resistance-Junction to Ambient	$R_{\theta JA}$	120	$^{\circ}\text{C}/\text{W}$

Electrical Characteristics

($T_A=25^{\circ}\text{C}$ Unless otherwise noted)

Parameter	Symbol	Conditions	Min.	Typ	Max.	Unit
Static						
Drain-Source Breakdown Voltage	$V_{(BR)DSS}$	$V_{GS}=0\text{V}, I_D=-250\mu\text{A}$	-30			V
Gate Threshold Voltage	$V_{GS(th)}$	$V_{DS}=V_{GS}, I_D=-250\mu\text{A}$	-0.6		-1.4	V
Gate Leakage Current	I_{GSS}	$V_{DS}=0\text{V}, V_{GS}=\pm 12\text{V}$			± 100	nA
Zero Gate Voltage Drain Current	I_{DSS}	$V_{DS}=-24\text{V}, V_{GS}=0\text{V}$			-1	uA
		$V_{DS}=-24\text{V}, V_{GS}=0\text{V}$ $T_A=85^{\circ}\text{C}$			-30	
On-State Drain Current	$I_{D(on)}$	$V_{DS} \leq -5\text{V}, V_{GS}=-10\text{V}$	-10			A
Drain-Source On-Resistance	$R_{DS(on)}$	$V_{GS}=-10\text{V}, I_D=-2.6\text{A}$		113	130	m Ω
		$V_{GS}=-4.5\text{V}, I_D=-2.2\text{A}$		142	160	
		$V_{GS}=-2.5\text{V}, I_D=-1.2\text{A}$		245	270	
Forward Transconductance	g_{FS}	$V_{DS}=-5\text{V}, I_D=-4.0\text{A}$		10		S
Diode Forward Voltage	V_{SD}	$I_S=-1.7\text{A}, V_{GS}=0\text{V}$		-0.7	-1.3	V
Dynamic						
Total Gate Charge	Q_g	$V_{DS}=-15\text{V}, V_{GS}=-4.5\text{V}$ $I_D \equiv -2.0\text{A}$		4	6	nC
Gate-Source Charge	Q_{gs}			0.6		
Gate-Drain Charge	Q_{gd}			1.5		
Input Capacitance	C_{iss}	$V_{DS}=-15\text{V}, V_{GS}=0\text{V}$ $f=1\text{MHz}$		230		pF
Output Capacitance	C_{oss}			40		
Reverse Transfer Capacitance	C_{rss}			25		
Turn-On Time	$t_{d(on)}$	$V_{DD}=-15\text{V}, R_L=15\Omega$ $I_D \equiv -1.0\text{A}, V_{GEN}=-10\text{V}$ $R_G=6\Omega$		5	10	ns
	t_r			8	15	
Turn-Off Time	$t_{d(off)}$			15	30	
	t_f			15	30	



Typical Characteristics

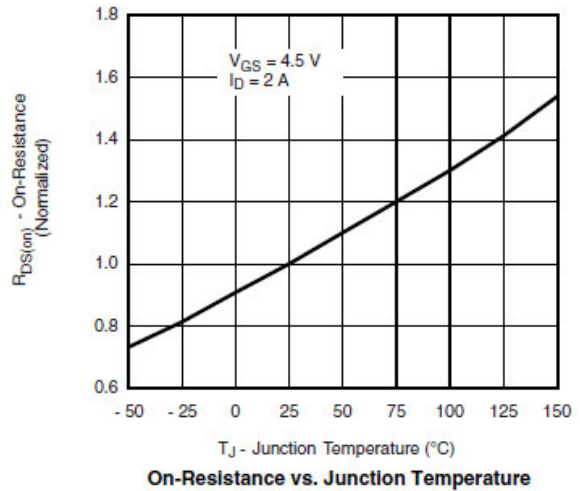
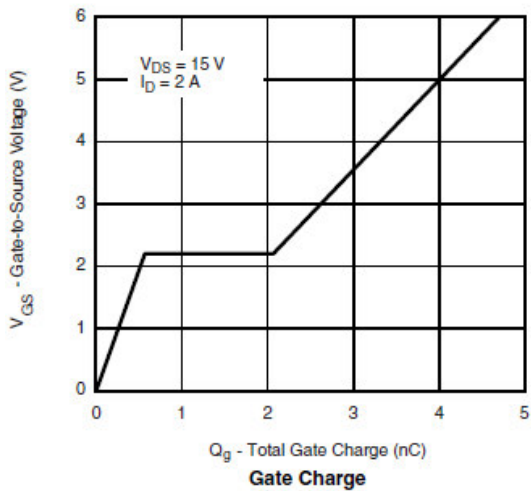
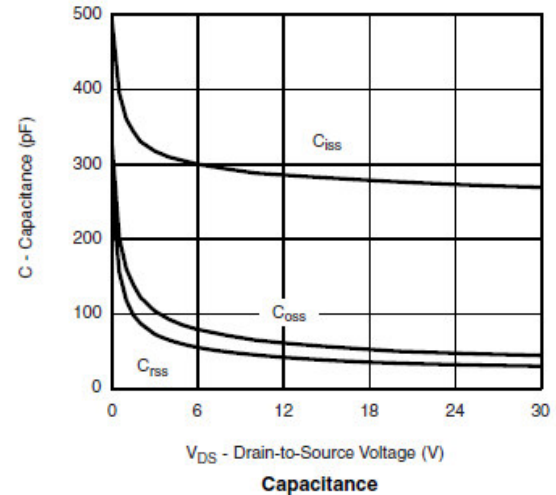
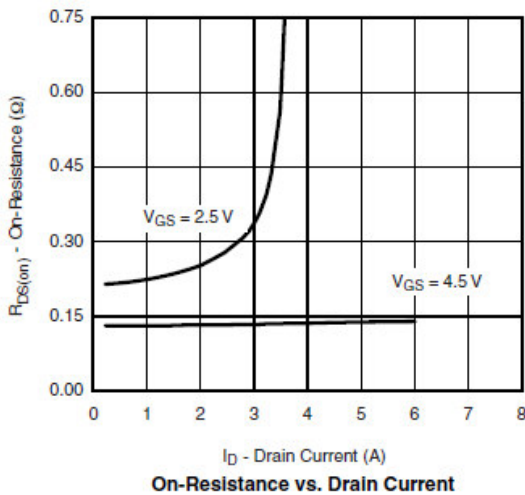
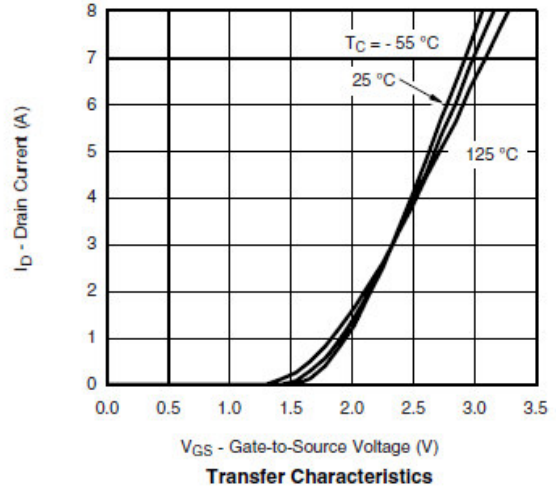
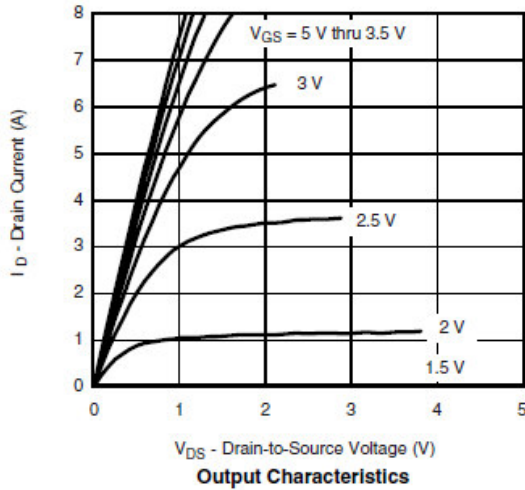



Typical Characteristics

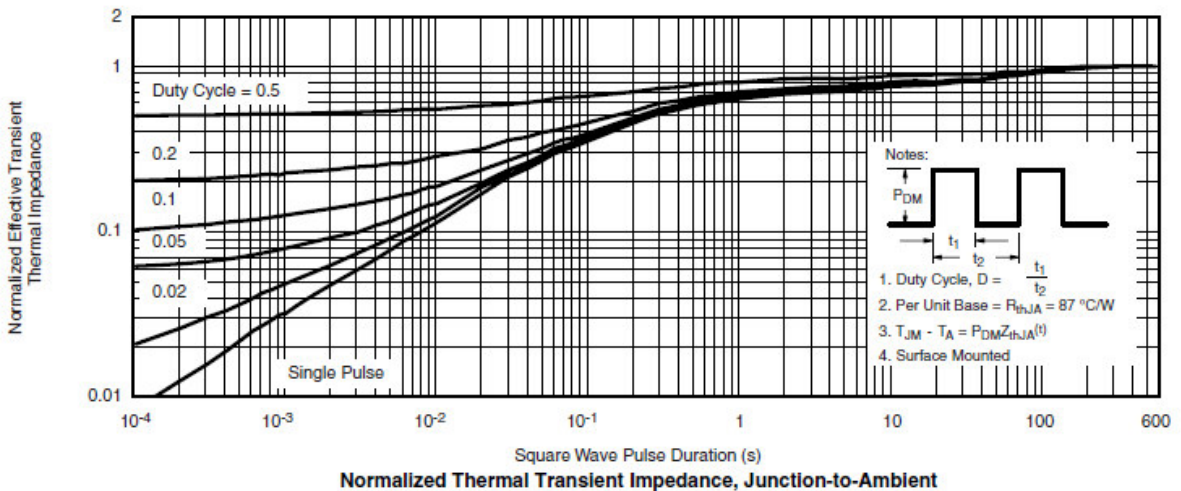
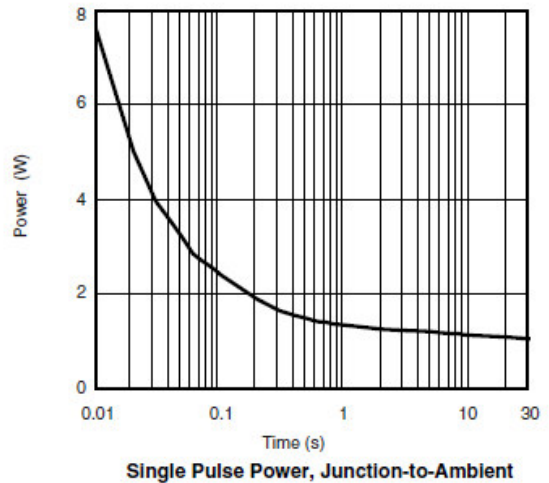
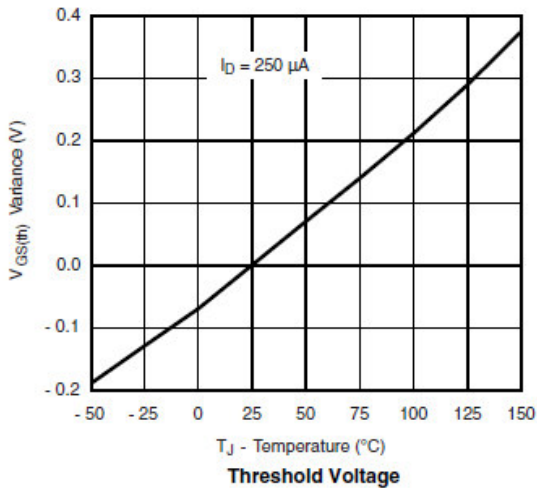
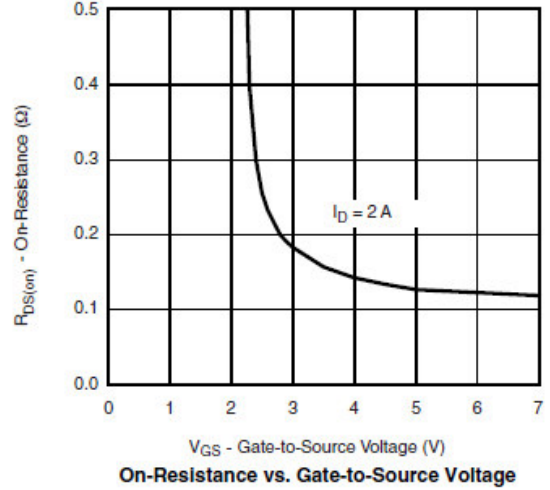
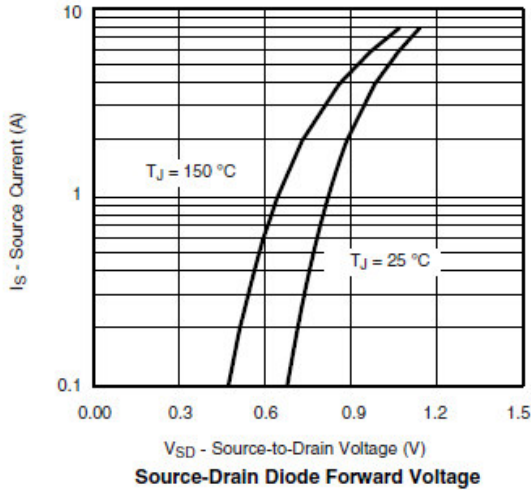



Typical Characteristics

Gate Charge Test Circuit & Waveform

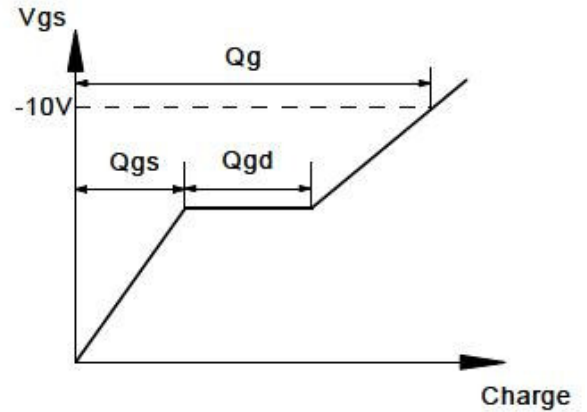
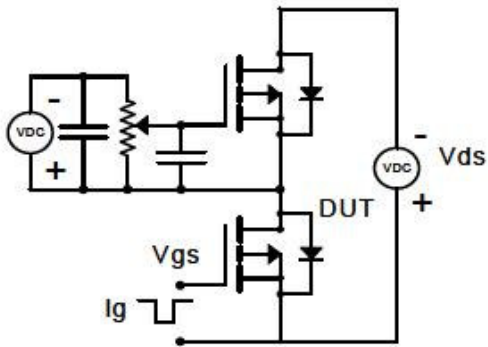

Resistive Switching Test Circuit & Waveforms

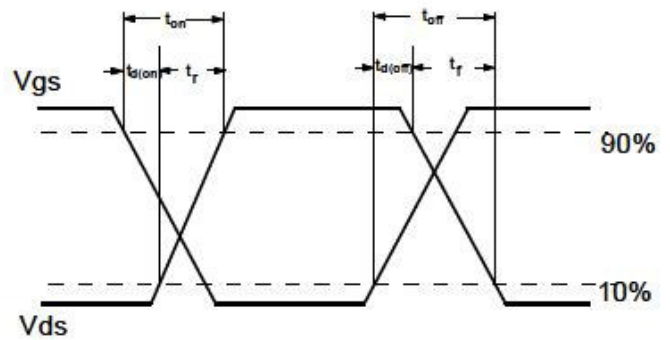
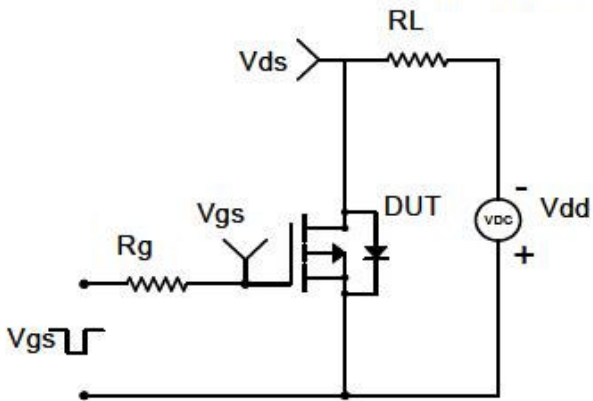

Diode Recovery Test Circuit & Waveforms

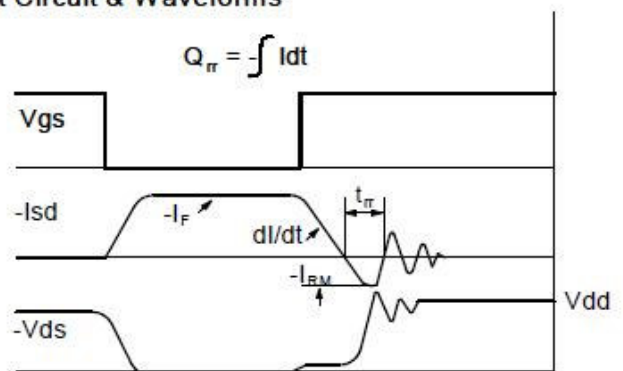
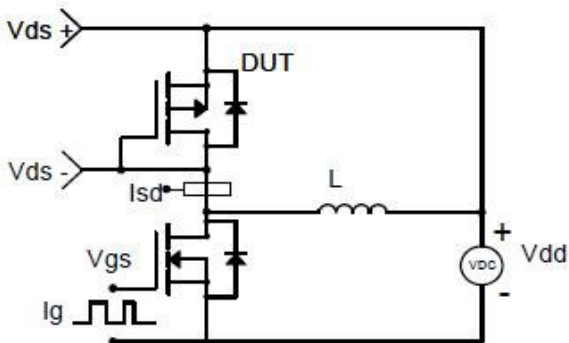



Package Information (SOT-23)

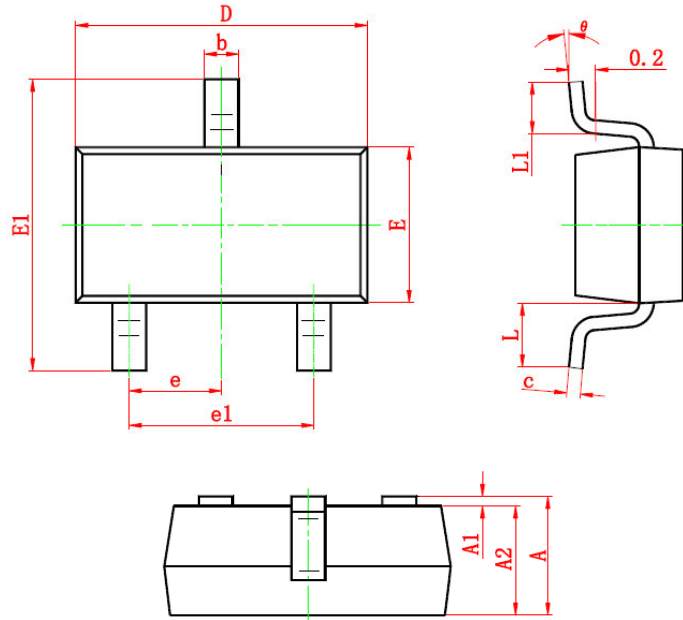

Symbol	Dimensions In Millimeters		Dimensions In Inches	
	Min	Max	Min	Max
A	0.900	1.200	0.035	0.043
A1	0.000	0.100	0.000	0.004
A2	0.900	1.100	0.035	0.039
b	0.300	0.500	0.012	0.020
c	0.080	0.150	0.003	0.006
D	2.800	3.000	0.110	0.118
E	1.200	1.400	0.047	0.055
E1	2.250	2.550	0.089	0.100
e	0.950 TYP		0.037 TYP	
e1	1.800	2.000	0.071	0.079
L	0.550 REF		0.022 REF	
L1	0.300	0.500	0.012	0.020
θ	0°	8°	0°	6°

©2010 Alfa-MOS Technology Corp.
 2F, No.80, Sec.1, Cheng Kung Rd., Nan Kang Dist., Taipei City 115, Taiwan (R.O.C.)
 Tel : 886 2) 2651 3928
 Fax : 886 2) 2786 8483
 ©http://www.alfa-mos.com