



### General Description

AFP7433, P-Channel enhancement mode MOSFET, uses Advanced Trench Technology to provide excellent  $R_{DS(ON)}$ , low gate charge.

These devices are particularly suited for low voltage power management, such as smart phone and notebook computer and other battery powered circuits, and low in-line power loss are needed in commercial industrial surface mount applications.

### Features

- -30V/-4.2A,  $R_{DS(ON)}=60m\Omega@V_{GS}=-10.0V$
- -30V/-3.2A,  $R_{DS(ON)}=80m\Omega@V_{GS}=-4.5V$
- Super high density cell design for extremely low  $R_{DS(ON)}$
- Exceptional on-resistance and maximum DC current capability
- SOT-363 package design

### Pin Description ( SOT-363 )

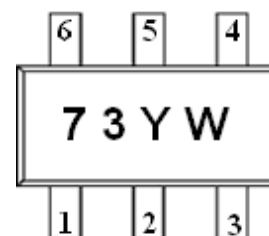
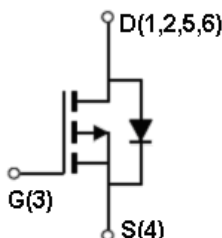
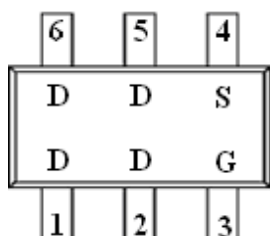

### Application

- Power Management in Note book
- Portable Equipment
- Battery Powered System
- Net Working System

### Pin Define

Pin	Symbol	Description
1	D	Drain
2	D	Drain
3	G	Gate
4	S	Source
5	D	Drain
6	D	Drain

### Ordering Information

Part Ordering No.	Part Marking	Package	Unit	Quantity
AFP7433S36RG	73YW	SOT-363	Tape & Reel	3000 EA

※ 73 parts code

※ Y year code ( 0 ~ 9 )

※ W week code ( A ~ Z = 1 ~ 26 / a ~ z = 27 ~ 52 )

※ AFP7433S36RG : 7" Tape & Reel ; Pb- Free ; Halogen -Free



**Absolute Maximum Ratings**

(T<sub>A</sub>=25°C Unless otherwise noted)

Parameter	Symbol	Typical	Unit
Drain-Source Voltage	V <sub>DSS</sub>	-30	V
Gate –Source Voltage	V <sub>GSS</sub>	±20	V
Continuous Drain Current(T <sub>J</sub> =150°C)	I <sub>D</sub>	T <sub>A</sub> =25°C	-4.2
		T <sub>A</sub> =70°C	-3.2
Pulsed Drain Current	I <sub>DM</sub>	-8	A
Continuous Source Current(Diode Conduction)	I <sub>S</sub>	-1.4	A
Power Dissipation	P <sub>D</sub>	T <sub>A</sub> =25°C	1.5
		T <sub>A</sub> =70°C	1.0
Operating Junction Temperature	T <sub>J</sub>	150	°C
Storage Temperature Range	T <sub>STG</sub>	-55/150	°C
Thermal Resistance-Junction to Ambient	R <sub>θJA</sub>	120	°C/W

**Electrical Characteristics**

(T<sub>A</sub>=25°C Unless otherwise noted)

Parameter	Symbol	Conditions	Min.	Typ	Max.	Unit
<b>Static</b>						
Drain-Source Breakdown Voltage	V <sub>(BR)DSS</sub>	V <sub>GS</sub> =0V, I <sub>D</sub> =-250uA	-30			V
Gate Threshold Voltage	V <sub>GS(th)</sub>	V <sub>DS</sub> =V <sub>GS</sub> , I <sub>D</sub> =-250uA	-1.0		-2.5	V
Gate Leakage Current	I <sub>GSS</sub>	V <sub>DS</sub> =0V, V <sub>GS</sub> =±12V			±100	nA
Zero Gate Voltage Drain Current	I <sub>DSS</sub>	V <sub>DS</sub> =-24V, V <sub>GS</sub> =0V			-1	uA
		V <sub>DS</sub> =-24V, V <sub>GS</sub> =0V T <sub>A</sub> =85°C			-30	
On-State Drain Current	I <sub>D(on)</sub>	V <sub>DS</sub> ≤ -5V, V <sub>GS</sub> =-10V	-10			A
Drain-Source On-Resistance	R <sub>DS(on)</sub>	V <sub>GS</sub> =-10.0V, I <sub>D</sub> =-3.6A		50	60	mΩ
		V <sub>GS</sub> =-4.5V, I <sub>D</sub> =-3.2A		65	80	
Forward Transconductance	g <sub>FS</sub>	V <sub>DS</sub> =-5V, I <sub>D</sub> =-4.0A		10		S
Diode Forward Voltage	V <sub>SD</sub>	I <sub>S</sub> =-1.7A, V <sub>GS</sub> =0V		-0.7	-1.3	V
<b>Dynamic</b>						
Total Gate Charge	Q <sub>g</sub>	V <sub>DS</sub> =-15V, V <sub>GS</sub> =-10V I <sub>D</sub> ≡-3.5A		10	18	nC
Gate-Source Charge	Q <sub>gs</sub>			1.6		
Gate-Drain Charge	Q <sub>gd</sub>			3.0		
Input Capacitance	C <sub>iss</sub>	V <sub>DS</sub> =-15V, V <sub>GS</sub> =0V f=1MHz		450		pF
Output Capacitance	C <sub>oss</sub>			95		
Reverse Transfer Capacitance	C <sub>rss</sub>			55		
Turn-On Time	t <sub>d(on)</sub>	V <sub>DD</sub> =-15V, R <sub>L</sub> =15Ω I <sub>D</sub> ≡-1.0A, V <sub>GEN</sub> =-10V R <sub>G</sub> =6Ω		8	18	ns
	t <sub>r</sub>			8	18	
Turn-Off Time	t <sub>d(off)</sub>			25	50	
	t <sub>f</sub>			25	35	



## Typical Characteristics

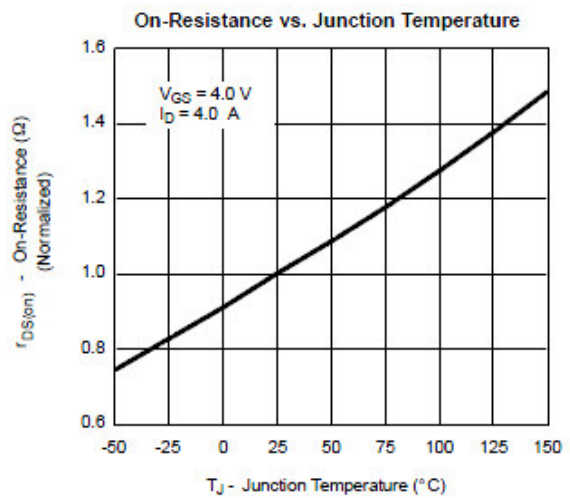
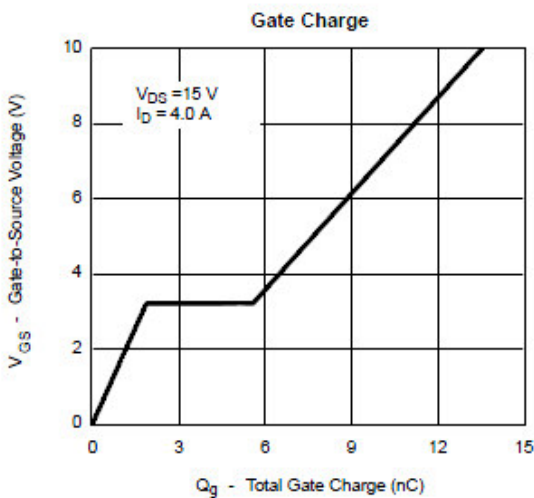
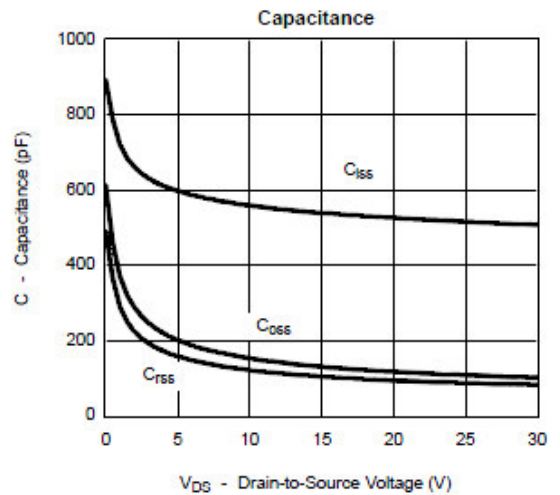
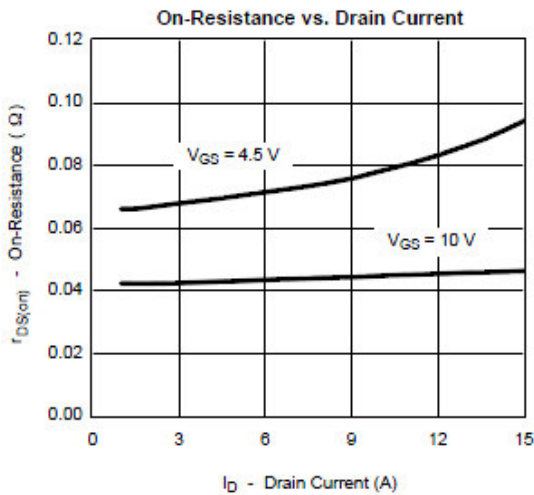
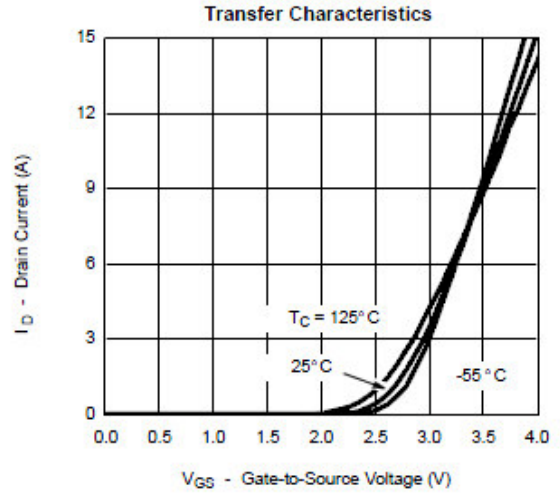
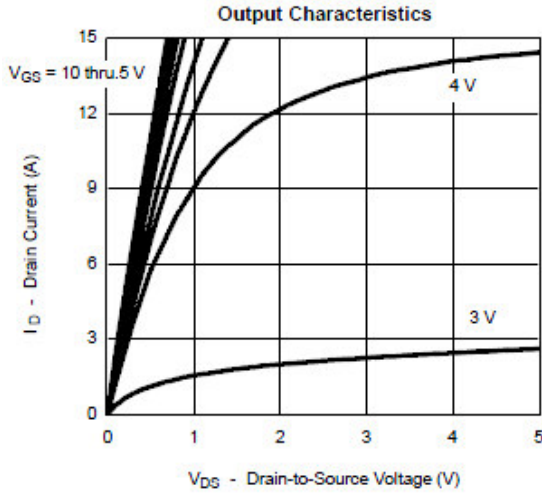



## Typical Characteristics

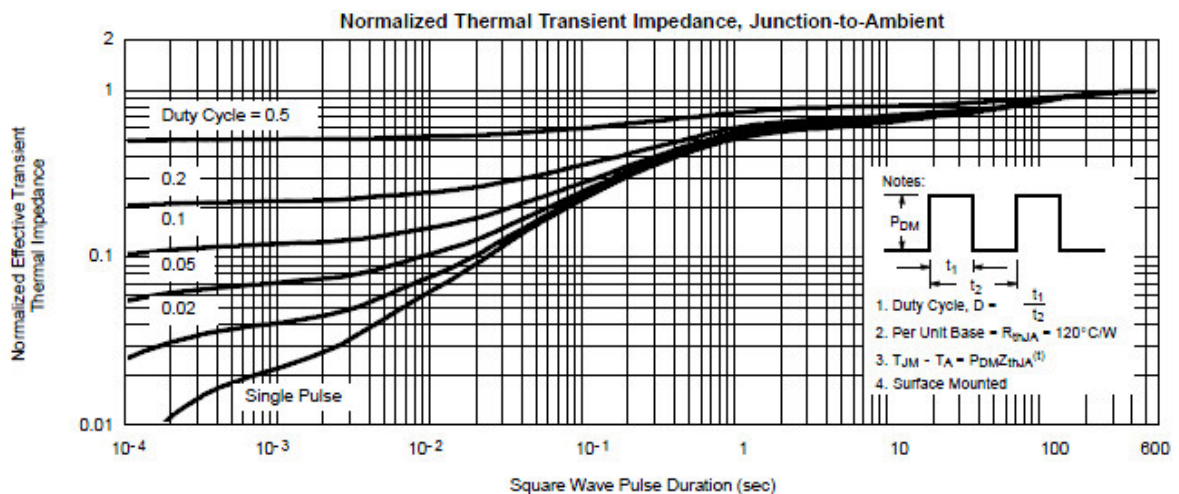
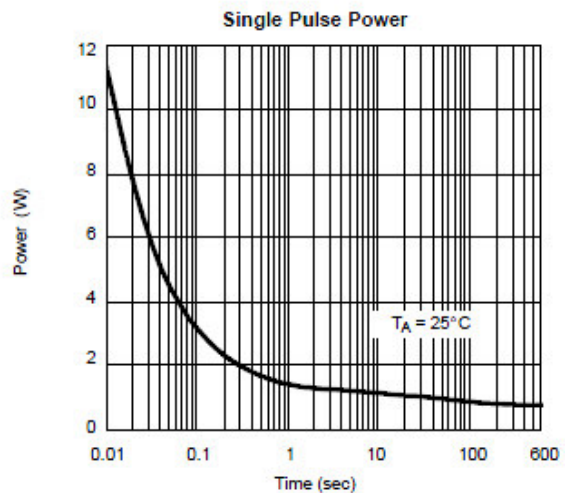
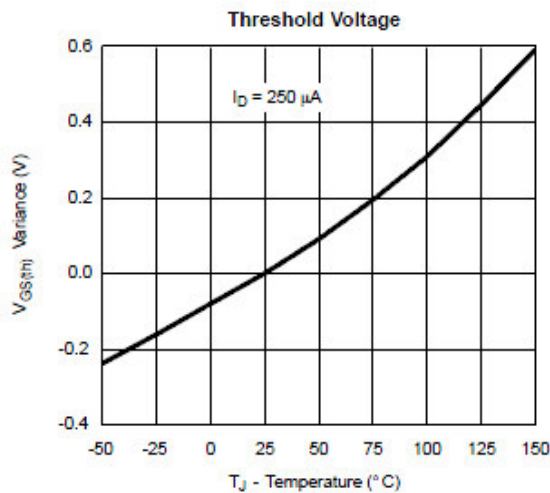
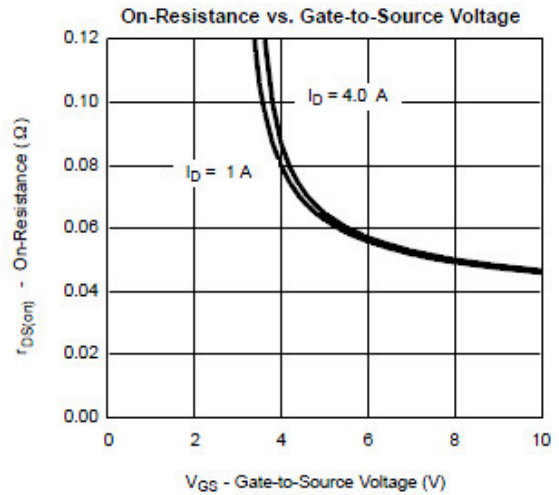
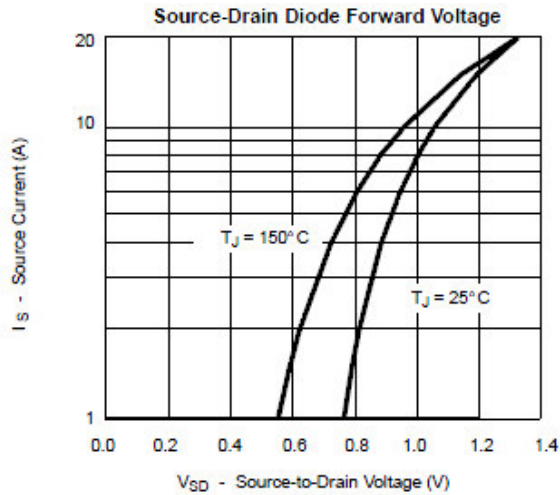



**Typical Characteristics**

Gate Charge Test Circuit & Waveform

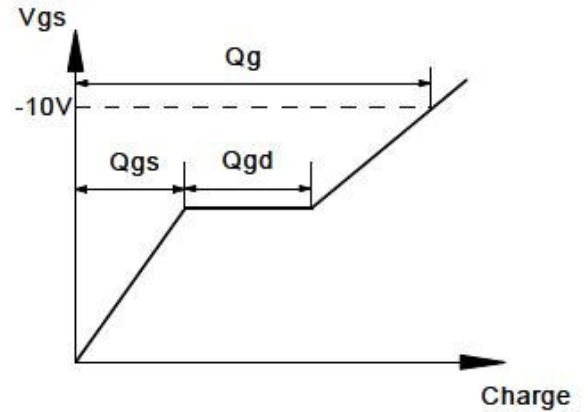
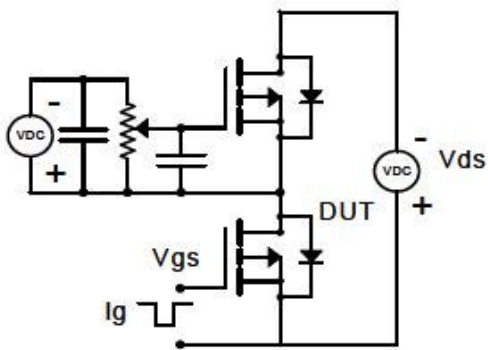

Resistive Switching Test Circuit & Waveforms

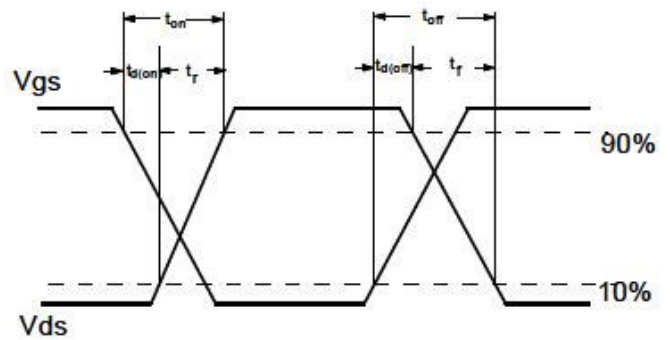
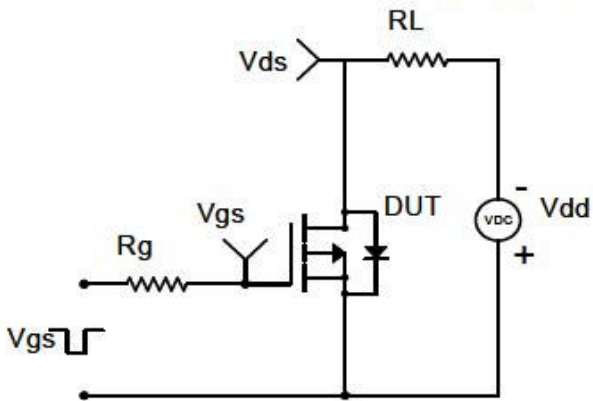

Diode Recovery Test Circuit & Waveforms

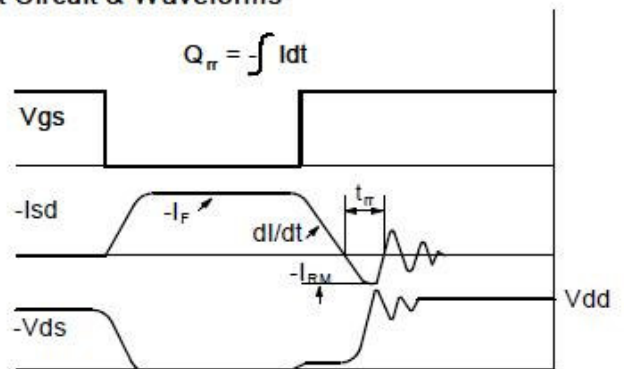
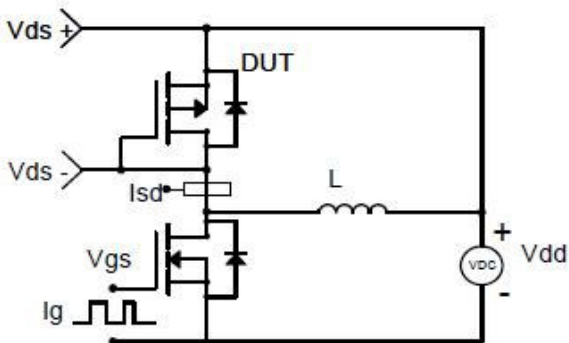



**Package Information ( SOT-363 )**

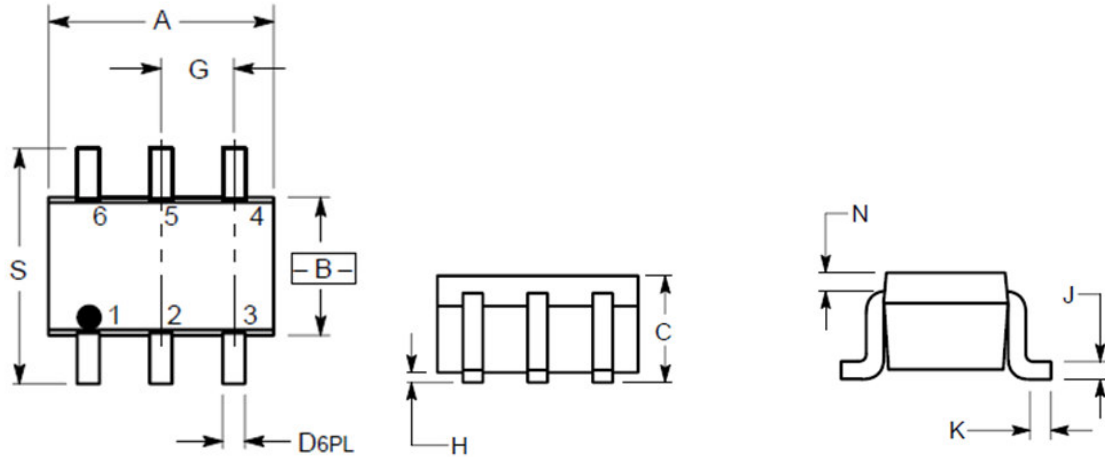

$\oplus$	0.2 (0.008) $\text{\textcircled{M}}$	B $\text{\textcircled{M}}$
----------	--------------------------------------	----------------------------

DIM	INCHES		MILLIMETERS	
	MIN	MAX	MIN	MAX
A	0.071	0.087	1.80	2.20
B	0.045	0.053	1.15	1.35
C	0.031	0.043	0.80	1.10
D	0.004	0.012	0.10	0.30
G	0.026 BSC		0.65 BSC	
H	---	0.004	---	0.10
J	0.004	0.010	0.10	0.25
K	0.004	0.012	0.10	0.30
N	0.008 REF		0.20 REF	
S	0.079	0.087	2.00	2.20

©2010 Alfa-MOS Technology Corp.  
 2F, No.80, Sec.1, Cheng Kung Rd., Nan Kang Dist., Taipei City 115, Taiwan (R.O.C.)  
 Tel : 886 2) 2651 3928  
 Fax : 886 2) 2786 8483  
 ©http://www.alfa-mos.com