



Your Total LCD Solution Provider

<http://www.orientdisplay.com>

**SPECIFICATION
FOR
LCD MODULE**

**MODULE NO: AFS176220TG-2.0-X300021
REVISION NO: 00**

Customer's Approval:

--

	SIGNATURE	DATE
PREPARED BY (RD ENGINEER)	Y LH	JUL -25-2011
CHECKED BY	FR. LI	JUL -25-2011
APPROVED BY	SEAN	JUL -25-2011

DOCUMENT REVISION HISTORY

Version	DATE	DESCRIPTION	CHANGED BY
00	Jul-25-2011	First Issue	Ylh

CONTENTS

1. Features & Mechanical specifications	1
2. Dimensional Outline	2
3. Block Diagram	3
4. Pin Description	4
5. Absolute Maximum Ratings	5
6. Electrical Characteristics	5
7. Backlight Specification	5
8. Electro-Optical Characteristics	6
9. Instruction Description	9
10. AC Characteristics	11
11. Quality Specification	13

1. Features & Mechanical Specifications

Item	Contents	Unit
	LCD	
LCD Type	TFT / Transmissive / Normally White	--
Viewing direction	12:00	--
Backlight	White LED x 3 in Parallel	--
Interface	8080-8bit parallel bus interface	--
Driver IC	ST7775R	--
Outline Dimension	41.5(W) ×49.1(H) × 2.4(T)	mm
Glass area (W×H×T)	35.1 ×43.0 /46.2 × 0.5	mm
Active area (W×H)	31.68 × 39.6	mm
Number of Dots	176(RGB) × 220	--
Dot pitch (W×H)	0.06 × 0.18	mm
Pixel pitch (W×H)	0.18 × 0.18	mm
Operating Temperature	-10 ~ +70	°C
Storage temperature	-30 ~ +80	°C

2. Dimensional Outline

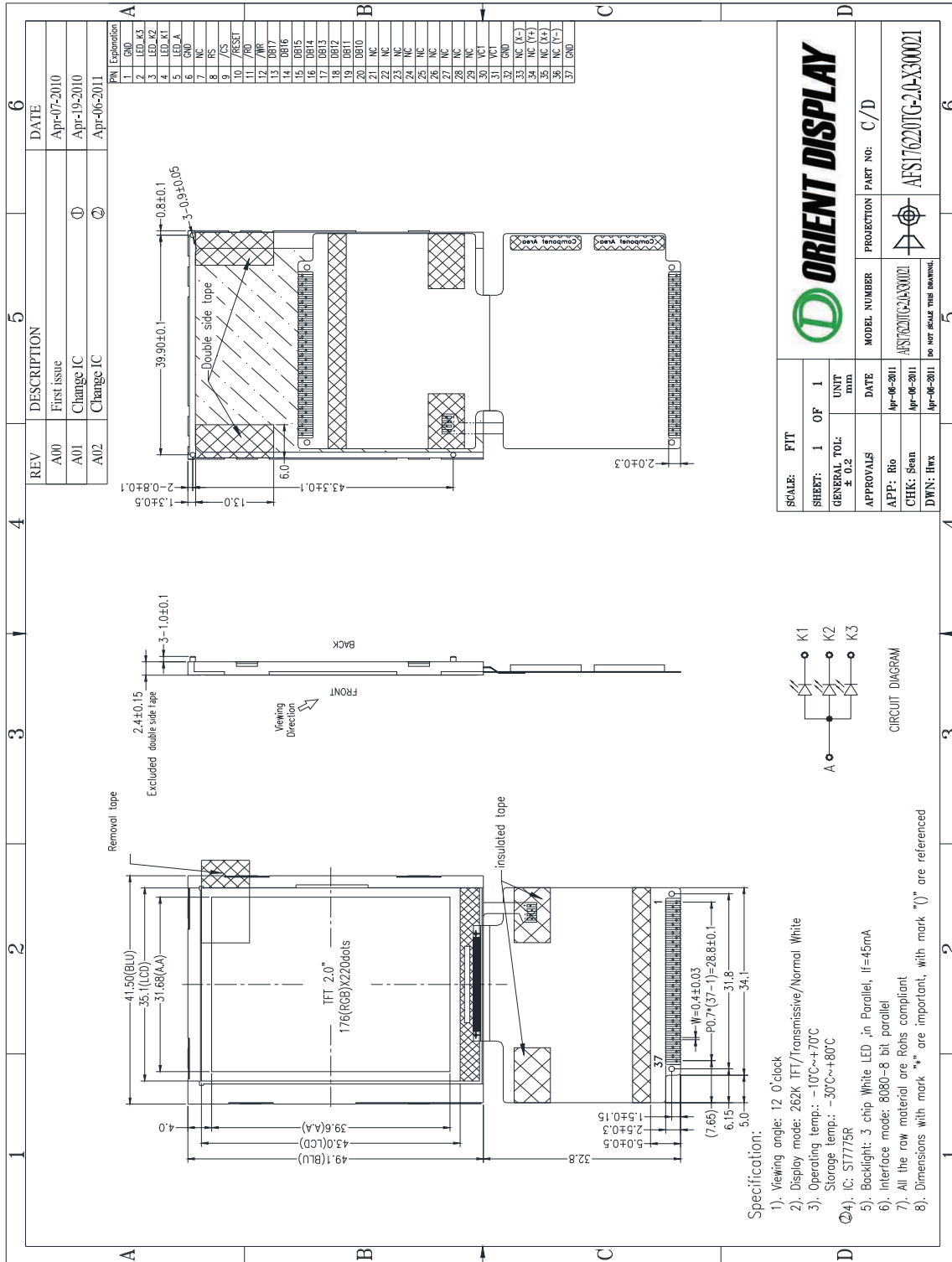

Figure 1. Dimensional outline

3. Block Diagram

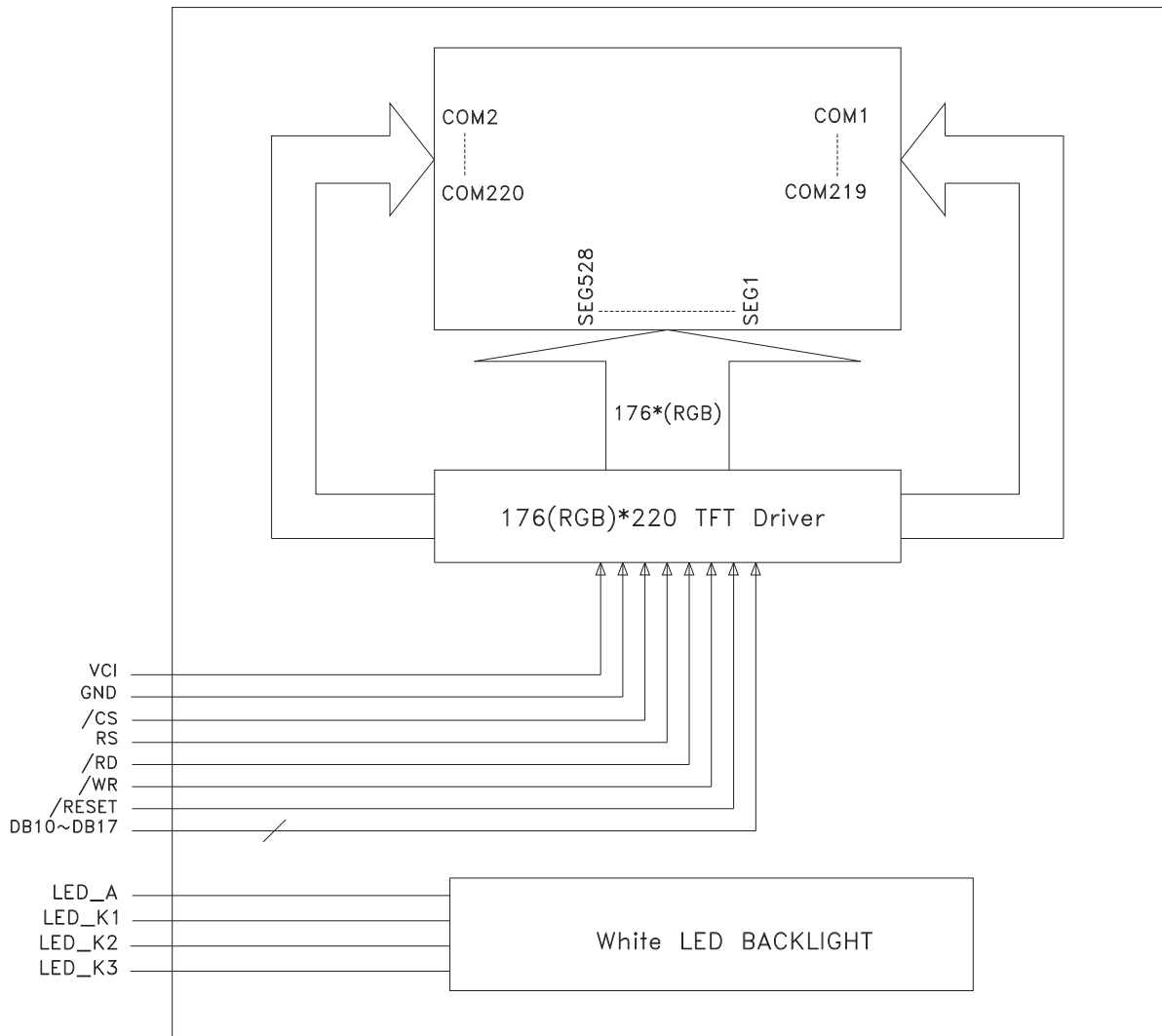

Figure 2. Block diagram

4. Pin Description

PIN No.	SYMBOL	Function
1	GND	Ground
2	LED_K3	Backlight LED3 Cathode
3	LED_K2	Backlight LED2 Cathode
4	LED_K1	Backlight LED1 Cathode
5	LED_A	Backlight LED Anode
6	GND	Ground
7	NC	No Connection
8	RS	Display data/command selection pin Low: command data High: display data or parameter
9	/CS	Chip Select Signal ("Low" enable)
10	/RESET	Reset pin. (Active Low)
11	/RD	Read signal.
12	/WR	Write signal.
13~20	DB17~DB10	Data Bus
21~29	NC	No Connection
30~31	VCI	A supply voltage to the analog circuit
32	GND	Ground
33	NC(X-)	No Connection
34	NC(Y+)	No Connection
35	NC(X+)	No Connection
36	NC(Y-)	No Connection
37	GND	Ground

5. Absolute Maximum Ratings

Item	Symbol	Rating	Unit
Supply Voltage range	VCI	-0.3 to +4.6	V
I/O supply voltage range	IOVCC	-0.3 to +4.6	V
Operating Temperature range	TOP	-10 to +70	°C
Storage Temperature range	TST	-30 to +80	°C

6. Electrical Characteristics

DC Characteristics

Item	Symbol	Min.	Type.	Max.	Unit
Driver Supply Voltage	VCI	2.5	2.75	3.3	V

7. Backlight Characteristics

White LED × 3 in parallel

(Ta = 25°C)

Item	Symbol	Condition	Min	Typ	Max	Unit
Forward Voltage	VF	IF=45mA	-	3.2	-	V
Uniformity	△Bp	-	80	-	-	%
Luminance for LCD	Lv	IF=45mA	2000		-	cd/m ²

8. Electro-Optical Characteristics

Item	Symbol	Condition	Min.	Typ.	Max.	Unit	Note	
Transmittance (without Polarizer)	T(%)	—	—	16.0	—	—		
Contrast Ratio	CR	$\Theta=0$	400	500	—	—	(1)(2)	
Response time	Rising	T_R	Normal viewing angle — —	—	2	4	msec	(1)(3)
	Falling	T_F		—	6	12		
Color gamut	S(%)			60		%		
Color chromaticity (CIE1931)	White	W_x		0.283	0.303	0.323	(1)(4) CF glass	
		W_y		0.305	0.325	0.345		
	Red	R_x		0.606	0.626	0.646		
		R_y		0.314	0.334	0.354		
	Green	G_x		0.257	0.277	0.297		
		G_y		0.529	0.549	0.569		
Blue	B_x		0.122	0.142	0.162			
	B_y		0.102	0.122	0.142			
Viewing angle	Hor.	Θ_L	CR>10	35	45	—		
		Θ_R		35	45	—		
	Ver.	Θ_U		35	45	—		
		Θ_D		10	20	—		
Optima View Direction	12 O'clock						(5)	

Measuring Condition

- Measuring surrounding : dark room
- Ambient temperature : $25\pm 2^\circ\text{C}$
- 15min. warm-up time.

Measuring Equipment

- FPM520 of Westar Display technologies, INC., which utilized SR-3 for Chromaticity and BM-5A for other optical characteristics.

Note (1) Definition of Viewing Angle :

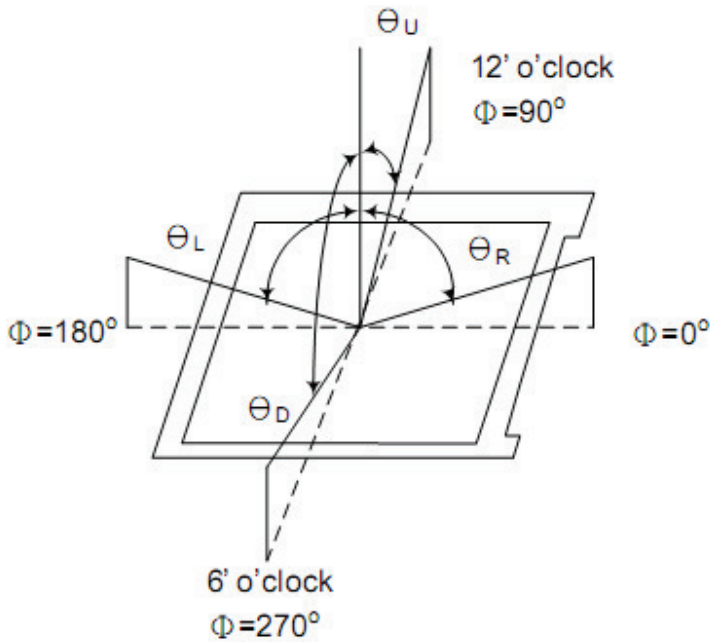

Note (2) Definition of Contrast Ratio(CR) :
measured at the center point of panel

$$CR = \frac{\text{Luminance with all pixels white}}{\text{Luminance with all pixels black}}$$

Note (3) Definition of Response Time : Sum of T_R and T_F

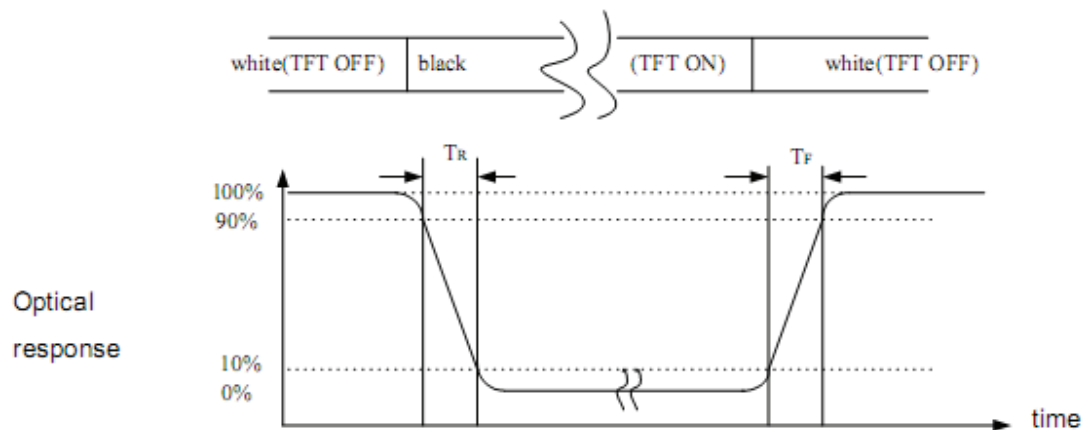

Note (4) Definition of optical measurement setup

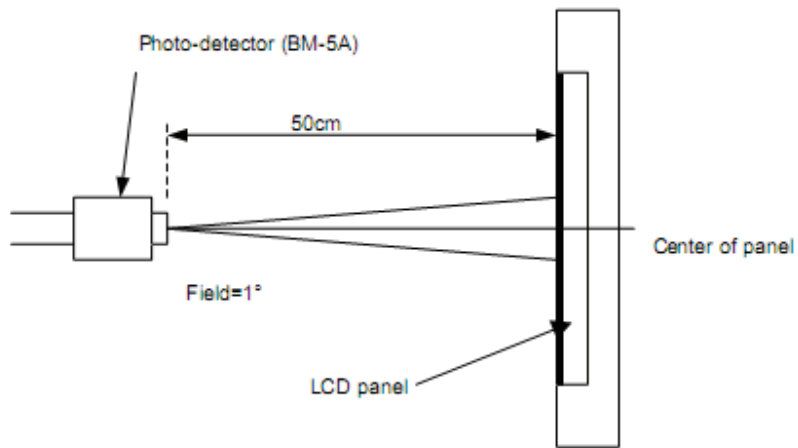

Note (5) Rubbing Direction (The different Rubbing Direction will cause the different optima view direction).

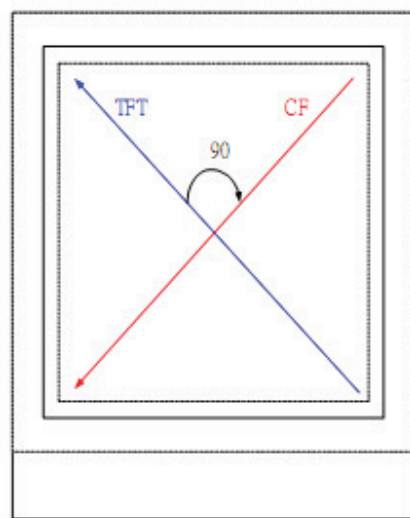

TFT Face up

9. Instruction Description

No	Registers	W/R	RS	D15	D14	D13	D12	D11	D10	D9	D8	D7	D6	D5	D4	D3	D2	D1	D0
1R	Index Register	W	0	-	-	-	-	-	-	-	-	ID7	ID6	ID5	ID4	ID3	ID2	ID1	ID0
00h	Driver Code Read	R	1	0	1	1	1	0	1	1	1	0	1	1	1	0	1	0	1
01h	Driver Output Control	W/R	1	VSPL	HSPL	DPL	EPL	0	SM	GS	SS	0	0	0	NL4	NL3	NL2	NL1	NL0
02h	LCD Driving Control	W/R	1	0	0	0	0	0	0	0	INV	0	0	0	0	0	0	0	0
03h	Entry Mode	W/R	1	0	0	0	BGR	0	0	MDT1	MDT0	0	0	ID1	ID0	AM	0	0	0
07h	Display Control 1	W/R	1	0	0	0	TEMON	0	0	0	0	0	0	0	GON	CL	REV	D1	D0
08h	Display control 2	W/R	0	0	0	0	FP3	FP2	FP1	FP0	0	0	0	0	BP3	BP2	BP1	BP0	0
08h	Display Control 4	W/R	1	0	0	0	0	0	0	0	0	0	0	0	0	RTN3	RTN2	RTN1	RTN0
0Ch	RGB Display Interface Control 1	W/R	1	0	0	0	0	0	0	0	RM	0	0	0	DM	0	0	RIM1	RIM0
0Fh	Frame Marker Position	W/R	1	0	0	0	0	0	0	0	0	0	0	0	0	0	0	0	OSC_EN
10h	Power Control 1	W/R	1	0	0	0	0	0	0	0	0	0	0	0	0	0	0	SLP	STB
11h	Power Control 2	W/R	1	0	0	0	APON	0	0	0	0	0	0	0	0	0	0	0	0
20h	Horizontal DRAM Address Set	W/R	1	0	0	0	0	0	0	0	0	AD7	AD6	AD5	AD4	AD3	AD2	AD1	AD0
21h	Vertical DRAM Address Set	W/R	1	0	0	0	0	0	0	0	0	AD15	AD14	AD13	AD12	AD11	AD10	AD9	AD8
22h	Write Data to GRAM	W	1	DRAM Write Data (WD17-0) / Read Data (RD17-0)															
22h	Read Data from GRAM	R	1																
28h	Software Reset	W	1	0	0	0	0	0	0	0	0	0	0	0	0	0	0	0	0
30h	Gate Scan Control	W/R	1	0	0	0	0	0	0	0	0	0	0	0	SCN4	SCN3	SCN2	SCN1	SCN0
31h	Vertical Scroll Control 1	W/R	1	0	0	0	0	0	0	0	0	SEA7	SEA6	SEA5	SEA4	SEA3	SEA2	SEA1	SEA0
32h	Vertical Scroll Control 2	W/R	1	0	0	0	0	0	0	0	0	SSA7	SSA6	SSA5	SSA4	SSA3	SSA2	SSA1	SSA0
33h	Vertical Scroll Control 3	W/R	1	0	0	0	0	0	0	0	0	SST7	SST6	SST5	SST4	SST3	SST2	SST1	SST0
34h	Partial Driving Control 1	W/R	1	0	0	0	0	0	0	0	0	SE17	SE16	SE15	SE14	SE13	SE12	SE11	SE10
35h	Partial Driving Control 2	W/R	1	0	0	0	0	0	0	0	0	SS17	SS16	SS15	SS14	SS13	SS12	SS11	SS10
36h	Horizontal Address End Position	W/R	1	0	0	0	0	0	0	0	0	HEA7	HEA6	HEA5	HEA4	HEA3	HEA2	HEA1	HEA0
37h	Horizontal Address Start Position	W/R	1	0	0	0	0	0	0	0	0	HSA7	HSA6	HSA5	HSA4	HSA3	HSA2	HSA1	HSA0
38h	Vertical Address End Position	W/R	1	0	0	0	0	0	0	0	0	VEA7	VEA6	VEA5	VEA4	VEA3	VEA2	VEA1	VEA0

39h	Vertical Address Start Position	W/R	1	0	0	0	0	0	0	0	0	VSA7	VSA6	VSA5	VSA4	VSA3	VSA2	VSA1	VSA0	
50h	Gamma Control 1	W/R	1	0	0	0	0	0	KP1[2]	KP1[1]	KP1[0]	0	0	0	0	0	KP0[2]	KP0[1]	KP0[0]	
51h	Gamma Control 2	W/R	1	0	0	0	0	0	KP3[3]	KP3[2]	KP3[1]	KP3[0]	0	0	0	0	KP2[3]	KP2[2]	KP2[1]	KP2[0]
52h	Gamma Control 3	W/R	1	0	0	0	0	0	KP5[2]	KP5[1]	KP5[0]	0	0	0	0	0	KP4[3]	KP4[2]	KP4[1]	KP4[0]
53h	Gamma Control 4	W/R	1	0	0	SELV63 P[2]	SELV63 P[1]	SELV63 P[0]	SELV62 P[2]	SELV62 P[1]	SELV62 P[0]	SELV1 P[3]	SELV1 P[2]	SELV1 P[1]	SELV1 P[0]	SELV0 P[3]	SELV0 P[2]	SELV0 P[1]	SELV0 P[0]	
54h	Gamma Control 5	W/R	1	0	0	0	0	VOS0 P[3]	VOS0 P[2]	VOS0 P[1]	VOS0 P[0]	0	0	0	0	VRF0 P[3]	VRF0 P[2]	VRF0 P[1]	VRF0 P[0]	
55h	Gamma Control 6	W/R	1	0	0	0	0	0	KN1[2]	KN1[1]	KN1[0]	0	0	0	0	0	KN0[2]	KN0[1]	KN0[0]	
56h	Gamma Control 7	W/R	1	0	0	0	0	0	KN3[3]	KN3[2]	KN3[1]	KN3[0]	0	0	0	0	KN2[3]	KN2[2]	KN2[1]	KN2[0]
57h	Gamma Control 8	W/R	1	0	0	0	0	0	KN5[2]	KN5[1]	KN5[0]	0	0	0	0	0	KN4[3]	PKN4[2]	KN4[1]	KN4[0]
58h	Gamma Control 9	W/R	1	0	0	SELV63 N[2]	SELV63 N[1]	SELV63 N[0]	SELV62 N[2]	SELV62 N[1]	SELV62 N[0]	SELV1 N[3]	SELV1 N[2]	SELV1 N[1]	SELV1 N[0]	SELV0 N[3]	SELV0 N[2]	SELV0 N[1]	SELV0 N[0]	
59h	Gamma Control 10	W/R	1	0	0	0	0	VOS0 N[3]	VOS0 N[2]	VOS0 N[1]	VOS0 N[0]	0	0	0	0	VRF0 N[3]	VRF0 N[2]	VRF0 N[1]	VRF0 N[0]	
65h	ID code	R		0	0	0	0	0	0	0	0	0	0	0	0	0	ID3	ID2	ID1	ID0
66h	SPI Read/Write Control	W/R	1	0	0	0	0	0	0	0	0	0	0	0	0	0	0	0	0	R/WX
B0h	Power Control 3	W/R	1	0	0	VCM5	VCM4	VCM3	VCM2	VCM1	VCM0	0	0	VGLSEL 1	VGLSEL 0	0	0	VGHBT1	VGHBT0	
B1h	Power Control 4	W/R	1	0	0	0	VRHN4	VRHN3	VRHN2	VRHN1	VRHN0	0	0	0	VRHP4	VRHP3	VRHP2	VRHP1	VRHP0	
B2h	Power Control 5	W/R	1	0	0	0	0	0	AVCLS2	AVCLS1	AVCLS0	0	0	BCLK_D1 V1	BCLK_D1 V0	0	AVDDS2	AVDDS1	AVDDS0	
D2h	NVM ID Code	W/R	1	0	0	0	0	0	0	0	0	0	0	0	0	0	ID3	ID2	ID1	ID0
D9h	NVM Control Status	W/R	1	0	0	0	0	0	0	0	0	0	VMF_EN	0	0	0	0	0	0	
DFh	NVM Write Command	W	1	0	0	0	0	0	0	0	0	1	0	1	0	0	1	0	1	
FAh	NVM Enable	W/R	1	0	0	0	0	0	0	0	0	PROG _MODE	0	0	0	0	1	MTP _PROG	0	
FEh	NVM VCOM Offset	W/R	1	0	0	0	0	0	0	0	0	1	0	0	VMF4	VMF3	VMF2	VMF1	VMF0	
FFh	NVM Command Enable	W	1	0	0	0	0	0	0	0	0	0	0	0	0	0	0	CMD1_ EN	CMD2_ EN	

10. AC Characteristics

8080 Series MCU Parallel Interface Characteristics: 18/16/9/8-bit Bus

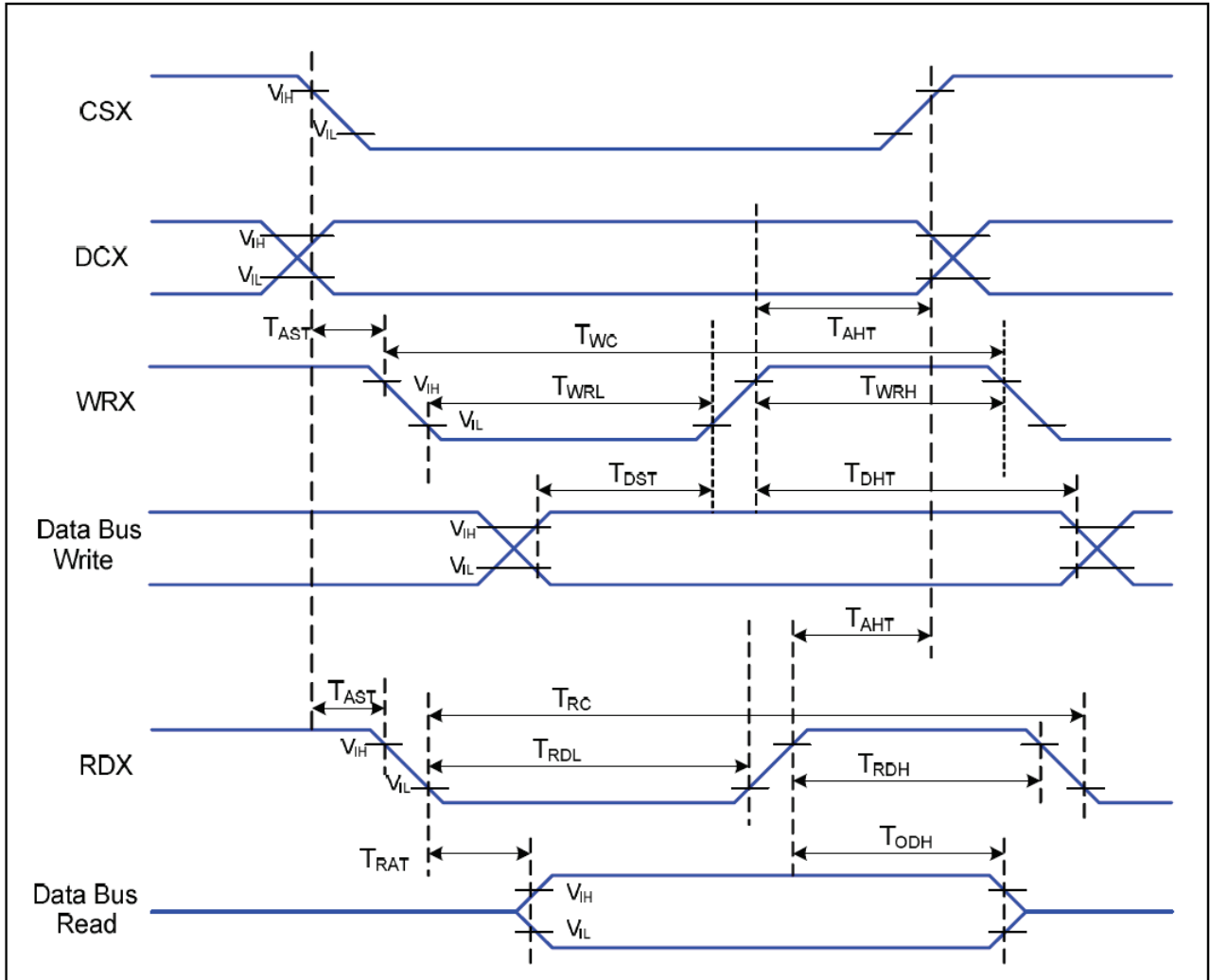

Parallel Interface Timing Characteristics (8080-Series MCU Interface)

Signal	Symbol	Parameter	Min	Max	Unit	Description
	TRAT	Read Access Time (ID)		TBD	ns	and 30pF Parallel Cap. To GND. TODH: 3K ohm Pull up or Down.
	TODH	Output Disable Time	TBD	TBD	ns	

Table 4 8080 Parallel Interface Characteristics

VDDI=1.65 to 3.3V, VDD=2.5 to 3.3V, AGND=DGND=0V, Ta=25 °C

Signal	Symbol	Parameter	Min	Max	Unit	Description
DCX	TAST	Address Setup Time	10	-	ns	
	TAHT	Address Hold Time (Write/Read)	5	-	ns	
WRX	TWC	Write Cycle	70	-	ns	
	TWRH	Control Pulse "H" Duration	35	-	ns	
	TWRL	Control Pulse "L" Duration	35	-	ns	
RDX	TRC	Read Cycle (ID)	300	-	ns	When Read ID Data
	TRDH	Control Pulse "H" Duration (ID)	150	-	ns	
	TRDL	Control Pulse "L" Duration (ID)	150	-	ns	
DB[17:0]	TDST	Data Setup Time	10	-	ns	TRAT, TRATFM: 3K ohm Pull up or Down and 30pF Parallel Cap. To GND. TODH: 3K ohm Pull up or Down.
	TDHT	Data Hold Time	15	-	ns	
	TRAT	Read Access Time (ID)	-	100	ns	
	TODH	Output Disable Time	50	-	ns	

8080 Parallel Interface Characteristics

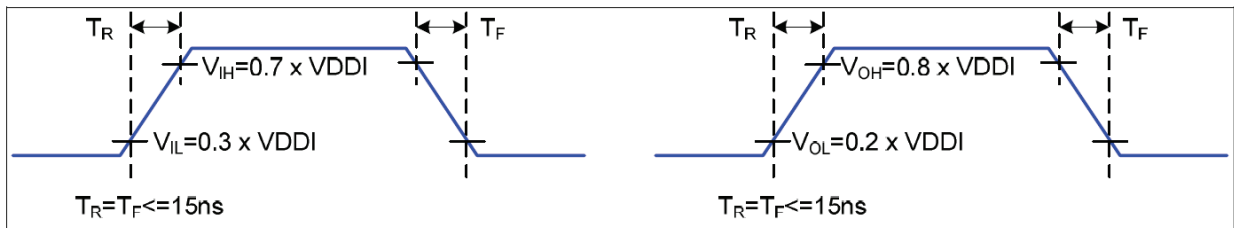

! Rising and Falling Timing for I/O Signal

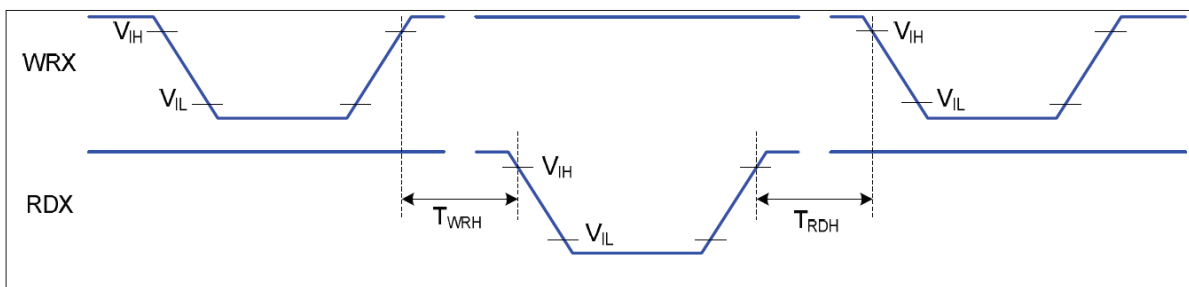

Write-to-Read and Read-to-Write Timing

Note: The rising time and falling time (T_r , T_f) of input signal and fall time are specified at 15 ns or less. Logic high and low levels are specified as 30% and 70% of VDDI for Input signals.

11. Quality Specifications

All The raw material are Rohs compliant.

11.1 Standard of the product appearance test

Manner of appearance test: The inspection should be performed in using 20W x 2 fluorescent lamps.

Distance between LCM and fluorescent lamps should be 100 cm or more. Distance between LCM and inspector eyes should be 30 cm or more.

Viewing direction for inspection is 45° from vertical against LCM.

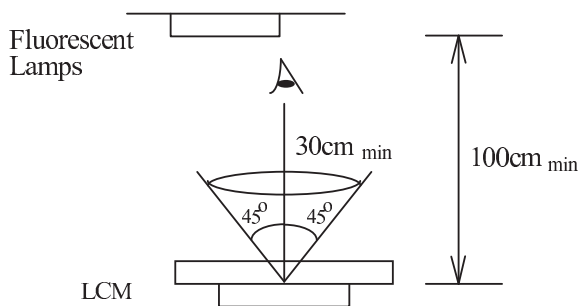

Definition of zone:

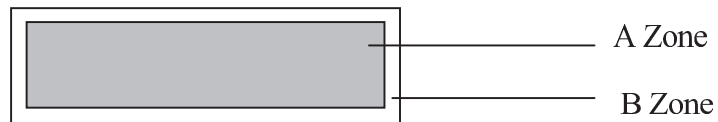

A Zone: viewing area

B Zone: outside viewing area

11.2 Specification of quality assurance

AQL inspection standard

Sampling method: MIL-STD-105E, Level II, single sampling

Defect classification (Note: * is not including)

Classify	Item		Note	AQL
Major	Display state	Short or open circuit	1	0.65
		LC leakage		
		Flickering		
		No display		
		Wrong viewing direction		
		Contrast defect (dim, ghost)	2	
		Back-light	1,8	
	Non-display	Flat cable or pin reverse	10	
Wrong or missing component		11		
Minor	Display state	Background color deviation	2	1.0
		Black spot and dust	3	
		Line defect, Scratch	4	
		Rainbow	5	
		Chip	6	
		Pin hole	7	
	Polarizer	Protruded	12	
		Bubble and foreign material	3	
	Soldering	Poor connection	9	
	Wire	Poor connection	10	
	TAB	Position, Bonding strength	13	

Note on defect classification

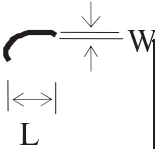
No.	Item	Criterion																				
1	Short or open circuit	Not allow																				
	LC leakage																					
	Flickering																					
	No display																					
	Wrong viewing direction																					
	Wrong Back-light																					
2	Contrast defect	Refer to approval sample																				
	Background color deviation																					
3	Point defect, Black spot, dust (including Polarizer) $\phi = (X+Y)/2$	 <table border="1" data-bbox="916 963 1342 1252"> <thead> <tr> <th>Point Size</th> <th>Acceptable Qty.</th> </tr> </thead> <tbody> <tr> <td>$\phi \leq 0.10$</td> <td>Disregard</td> </tr> <tr> <td>$0.10 < \phi \leq 0.20$</td> <td>3</td> </tr> <tr> <td>$0.20 < \phi \leq 0.25$</td> <td>2</td> </tr> <tr> <td>$0.25 < \phi \leq 0.30$</td> <td>1</td> </tr> <tr> <td>$\phi > 0.30$</td> <td>0</td> </tr> </tbody> </table> <p style="text-align: right;">Unit: mm</p>	Point Size	Acceptable Qty.	$\phi \leq 0.10$	Disregard	$0.10 < \phi \leq 0.20$	3	$0.20 < \phi \leq 0.25$	2	$0.25 < \phi \leq 0.30$	1	$\phi > 0.30$	0								
Point Size	Acceptable Qty.																					
$\phi \leq 0.10$	Disregard																					
$0.10 < \phi \leq 0.20$	3																					
$0.20 < \phi \leq 0.25$	2																					
$0.25 < \phi \leq 0.30$	1																					
$\phi > 0.30$	0																					
4	Line defect, Scratch	 <table border="1" data-bbox="821 1422 1358 1697"> <thead> <tr> <th colspan="2">Line</th> <th>Acceptable Qty.</th> </tr> <tr> <th>L</th> <th>W</th> <th></th> </tr> </thead> <tbody> <tr> <td>---</td> <td>$0.02 \geq W$</td> <td>Disregard</td> </tr> <tr> <td>$4.0 \geq L$</td> <td>$0.03 \geq W > 0.02$</td> <td rowspan="2">2</td> </tr> <tr> <td>$2.0 \geq L$</td> <td>$0.05 \geq W > 0.03$</td> </tr> <tr> <td>$1.0 \geq L$</td> <td>$0.1 > W > 0.05$</td> <td>1</td> </tr> <tr> <td>---</td> <td>$0.1 < W$</td> <td>Applied as point defect</td> </tr> </tbody> </table> <p style="text-align: right;">Unit: mm</p>	Line		Acceptable Qty.	L	W		---	$0.02 \geq W$	Disregard	$4.0 \geq L$	$0.03 \geq W > 0.02$	2	$2.0 \geq L$	$0.05 \geq W > 0.03$	$1.0 \geq L$	$0.1 > W > 0.05$	1	---	$0.1 < W$	Applied as point defect
Line		Acceptable Qty.																				
L	W																					
---	$0.02 \geq W$	Disregard																				
$4.0 \geq L$	$0.03 \geq W > 0.02$	2																				
$2.0 \geq L$	$0.05 \geq W > 0.03$																					
$1.0 \geq L$	$0.1 > W > 0.05$	1																				
---	$0.1 < W$	Applied as point defect																				
5	Rainbow	Not more than two color changes across the viewing area.																				

No	Item	Criterion																																	
6	<p data-bbox="260 394 323 427">Chip</p> <p data-bbox="260 499 368 533">Remark:</p> <p data-bbox="316 537 448 602">X: Length direction</p> <p data-bbox="316 620 448 685">Y: Short direction</p> <p data-bbox="316 703 480 768">Z: Thickness direction</p> <p data-bbox="316 786 472 851">t: Glass thickness</p> <p data-bbox="316 869 480 934">W: Terminal Width</p>	<div data-bbox="571 432 938 611"> </div> <table border="1" data-bbox="962 432 1342 544"> <caption data-bbox="962 432 1222 465">Acceptable criterion</caption> <thead> <tr> <th>X</th> <th>Y</th> <th>Z</th> </tr> </thead> <tbody> <tr> <td>≤ 2</td> <td>0.5mm</td> <td>$\leq t/2$</td> </tr> </tbody> </table> <div data-bbox="571 745 911 925"> </div> <table border="1" data-bbox="951 730 1345 842"> <caption data-bbox="951 730 1211 763">Acceptable criterion</caption> <thead> <tr> <th>X</th> <th>Y</th> <th>Z</th> </tr> </thead> <tbody> <tr> <td>≤ 2</td> <td>0.5mm</td> <td>$\leq t$</td> </tr> </tbody> </table> <div data-bbox="571 1003 903 1227"> </div> <table border="1" data-bbox="967 1016 1345 1167"> <caption data-bbox="967 1016 1227 1050">Acceptable criterion</caption> <thead> <tr> <th>X</th> <th>Y</th> <th>Z</th> </tr> </thead> <tbody> <tr> <td>≤ 3</td> <td>≤ 2</td> <td>$\leq t$</td> </tr> <tr> <td colspan="2">shall not reach to ITO</td> <td></td> </tr> </tbody> </table> <div data-bbox="560 1350 951 1529"> </div> <table border="1" data-bbox="951 1379 1345 1491"> <caption data-bbox="951 1379 1211 1413">Acceptable criterion</caption> <thead> <tr> <th>X</th> <th>Y</th> <th>Z</th> </tr> </thead> <tbody> <tr> <td>Disregard</td> <td>≤ 0.2</td> <td>$\leq t$</td> </tr> </tbody> </table> <div data-bbox="560 1653 911 1832"> </div> <table border="1" data-bbox="951 1666 1313 1778"> <caption data-bbox="951 1666 1211 1700">Acceptable criterion</caption> <thead> <tr> <th>X</th> <th>Y</th> <th>Z</th> </tr> </thead> <tbody> <tr> <td>≤ 5</td> <td>≤ 2</td> <td>$\leq t/3$</td> </tr> </tbody> </table>	X	Y	Z	≤ 2	0.5mm	$\leq t/2$	X	Y	Z	≤ 2	0.5mm	$\leq t$	X	Y	Z	≤ 3	≤ 2	$\leq t$	shall not reach to ITO			X	Y	Z	Disregard	≤ 0.2	$\leq t$	X	Y	Z	≤ 5	≤ 2	$\leq t/3$
X	Y	Z																																	
≤ 2	0.5mm	$\leq t/2$																																	
X	Y	Z																																	
≤ 2	0.5mm	$\leq t$																																	
X	Y	Z																																	
≤ 3	≤ 2	$\leq t$																																	
shall not reach to ITO																																			
X	Y	Z																																	
Disregard	≤ 0.2	$\leq t$																																	
X	Y	Z																																	
≤ 5	≤ 2	$\leq t/3$																																	

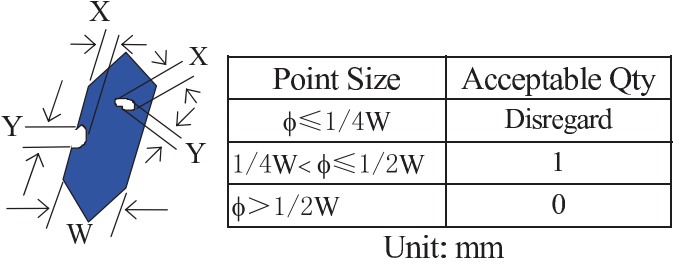
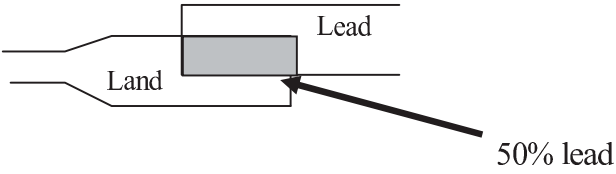
No.	Item	Criterion								
7	Segment pattern $W = \text{Segment width}$ $\phi = (X+Y)/2$	(1) Pin hole $\phi < 0.10\text{mm}$ is acceptable.  <table border="1" data-bbox="906 723 1358 896"> <thead> <tr> <th>Point Size</th> <th>Acceptable Qty</th> </tr> </thead> <tbody> <tr> <td>$\phi \leq 1/4W$</td> <td>Disregard</td> </tr> <tr> <td>$1/4W < \phi \leq 1/2W$</td> <td>1</td> </tr> <tr> <td>$\phi > 1/2W$</td> <td>0</td> </tr> </tbody> </table> <p style="text-align: center;">Unit: mm</p>	Point Size	Acceptable Qty	$\phi \leq 1/4W$	Disregard	$1/4W < \phi \leq 1/2W$	1	$\phi > 1/2W$	0
Point Size	Acceptable Qty									
$\phi \leq 1/4W$	Disregard									
$1/4W < \phi \leq 1/2W$	1									
$\phi > 1/2W$	0									
8	Back-light	(1) The color of backlight should correspond its specification. (2) Not allow flickering								
9	Soldering	(1) Not allow heavy dirty and solder ball on PCB. (The size of dirty refer to point and dust defect) (2) Over 50% of lead should be soldered on Land. 								
10	Wire	(1) Copper wire should not be rusted (2) Not allow crack on copper wire connection. (3) Not allow reversing the position of the flat cable. (4) Not allow exposed copper wire inside the flat cable.								
11*	PCB	(1) Not allow screw rust or damage. (2) Not allow missing or wrong putting of component.								

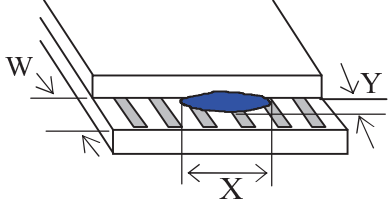
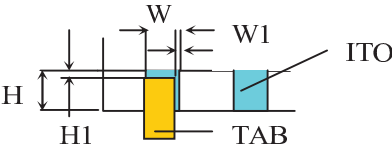
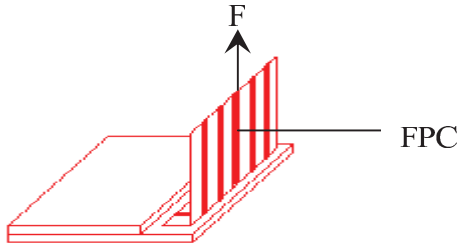
No	Item	Criterion
12	Protruded W: Terminal Width	 <p>Acceptable criteria: $Y \leq 0.4$</p>
13	TAB	<p>1. Position</p>  <div style="border: 1px solid black; padding: 5px; width: fit-content; margin-left: auto;"> $W1 \leq 1/3W$ $H1 \leq 1/3H$ </div> <p>2 FPC bonding strength test</p>  <p>$P (=F/FPC \text{ bonding width}) \geq 650\text{gf/cm}$, (speed rate: 1mm/min) 5pcs per SOA (shipment)</p>
14	Total no. of acceptable Defect	<p>A. Zone</p> <p>Maximum 2 minor non-conformities per one unit. Defect distance: each point to be separated over 10mm</p> <p>B. Zone</p> <p>It is acceptable when it is no trouble for quality and assembly in customer's end product.</p>

11.3 Reliability of LCM

Reliability test condition:

Item	Condition	Time (hrs)	Assessment
High temp. Storage	60°C	48	No abnormalities in functions and appearance
High temp. Operating	50°C	48	
Low temp. Storage	-20°C	48	
Low temp. Operating	-10°C	48	
Humidity	40°C/ 90%RH	48	
Temp. Cycle	-20°C ← 25°C →60°C (60 min ← 5 min → 60min)	10cycles	

Recovery time should be 24 hours minimum. Moreover, functions, performance and appearance shall be free from remarkable deterioration within 50,000 hours under ordinary operating and storage conditions room temperature (20±8°C), normal humidity (below 65% RH), and in the area not exposed to direct sunlight.

11.4 Precaution for using LCD/LCM

LCD/LCM is assembled and adjusted with a high degree of precision. Do not attempt to make any alteration or modification. The followings should be noted.

General Precautions:

1. LCD panel is made of glass. Avoid excessive mechanical shock or applying strong pressure onto the surface of display area.
2. The polarizer used on the display surface is easily scratched and damaged. Extreme care should be taken when handling. To clean dust or dirt off the display surface, wipe gently with cotton, or other soft material soaked with isopropyl alcohol, ethyl alcohol or trichlorotrifluoroethane, do not use water, ketone or aromatics and never scrub hard.
3. Do not tamper in any way with the tabs on the metal frame.
4. Do not make any modification on the PCB without consulting ORIENT DISPLAY.
5. When mounting a LCM, make sure that the PCB is not under any stress such as bending or twisting. Elastomer contacts are very delicate and missing pixels could result from slight dislocation of any of the elements.
6. Avoid pressing on the metal bezel, otherwise the elastomer connector could be deformed and lose contact, resulting in missing pixels and also cause rainbow on the display.
7. Be careful not to touch or swallow liquid crystal that might leak from a damaged cell. Any liquid crystal adheres to skin or clothes, wash it off immediately with soap and water.

Static Electricity Precautions:

1. CMOS-LSI is used for the module circuit; therefore operators should be grounded whenever he/she comes into contact with the module.
2. Do not touch any of the conductive parts such as the LSI pads; the copper leads on the PCB and the interface terminals with any parts of the human body.
3. Do not touch the connection terminals of the display with bare hand; it will cause disconnection or defective insulation of terminals.
4. The modules should be kept in anti-static bags or other containers resistant to static for storage.
5. Only properly grounded soldering irons should be used.
6. If an electric screwdriver is used, it should be grounded and shielded to prevent sparks.
7. The normal static prevention measures should be observed for work clothes and working benches.
8. Since dry air is inductive to static, a relative humidity of 50-60% is recommended.

Soldering Precautions:

1. Soldering should be performed only on the I/O terminals.
2. Use soldering irons with proper grounding and no leakage.
3. Soldering temperature: $280^{\circ}\text{C} \pm 10^{\circ}\text{C}$
4. Soldering time: 3 to 4 second.
5. Use eutectic solder with resin flux filling.
6. If flux is used, the LCD surface should be protected to avoid spattering flux.
7. Flux residue should be removed.

Operation Precautions:

1. The viewing angle can be adjusted by varying the LCD driving voltage V_o .
2. Since applied DC voltage causes electro-chemical reactions, which deteriorate the display, the applied pulse waveform should be a symmetric waveform such that no DC component remains. Be sure to use the specified operating voltage.
3. Driving voltage should be kept within specified range; excess voltage will shorten display life.
4. Response time increases with decrease in temperature.
5. Display color may be affected at temperatures above its operational range.
6. Keep the temperature within the specified range usage and storage. Excessive temperature and humidity could cause polarization degradation, polarizer peel-off or generate bubbles.
7. For long-term storage over 40°C is required, the relative humidity should be kept below 60%, and avoid direct sunlight.

Limited Warranty

ORIENT DISPLAY LCDs and modules are not consumer products, but may be incorporated by OD's customers into consumer products or components thereof, OD does not warrant that its LCDs and components are fit for any such particular purpose.

1. The liability of ORIENT DISPLAY is limited to repair or replacement on the terms set forth below. OD will not be responsible for any subsequent or consequential events or injury or damage to any personnel or user including third party personnel and/or user. Unless otherwise agreed in writing between OD and the customer, OD will only replace or repair any of its LCD which is found defective electrically or visually when inspected in accordance with OD general LCD inspection standard. (Copies available on request)
2. No warranty can be granted if any of the precautions state in handling liquid crystal display above has been disregarded. Broken glass, scratches on polarizer mechanical damages as well as defects that are caused accelerated environment tests are excluded from warranty.
3. In returning the LCD/LCM, they must be properly packaged; there should be detailed description of the failures or defect.