



**SPECIFICATION
FOR
LCD MODULE**

**MODULE NO: AFS320240TG-3.5-E300011
REVISION NO: 02**

Customer's Approval:

--

	SIGNATURE	DATE
PREPARED BY (RD ENGINEER)	FR. LI	JUN-25-2011
CHECKED BY	Y LH	JUN-25-2011
APPROVED BY	SEAN	JUN-25-2011

DOCUMENT REVISION HISTORY

Version	DATE	DESCRIPTION	CHANGED BY
00	Apr-21-2011	First Issue	Ylh
01	May-05-2011	Changed pin explanation	lhm
02	Jun-25-2011	Changed “Chapter 10”	Fr.li

CONTENTS

1. Features & Mechanical specifications	1
2. Dimensional Outline	2
3. Block Diagram	3
4. Pin Description	4
5. Absolute Maximum Ratings	5
6. Electrical Characteristics	5
7. Backlight Specification	5
8. Electro-Optical Characteristics	6
9. Instruction Description	9
10. AC Characteristics	10
11. Quality Specification	12

1. Features & Mechanical Specifications

Item	Contents	Unit
	LCD	
LCD Type	TFT / Transmissive / Normal White	--
Viewing direction	6 O'clock	--
Backlight	White LED BackLight	--
Interface	RGB interface	--
Driver IC	NT39016D	--
Outline Dimension	77.1(W) × 64.1(H) × 4.35(T)	mm
Glass area (W×H×T)	74.1 × 56.8 / 61.9 × 0.5	mm
Active area (W×H)	70.08 × 52.56	mm
Number of Dots	320(RGB) × 240	--
Dot pitch (W×H)	0.073 × 0.219	mm
Pixel pitch (W×H)	0.219 × 0.219	mm
Operating Temperature	-20 ~ +70	°C
Storage temperature	-30 ~ +80	°C

2. Dimensional Outline

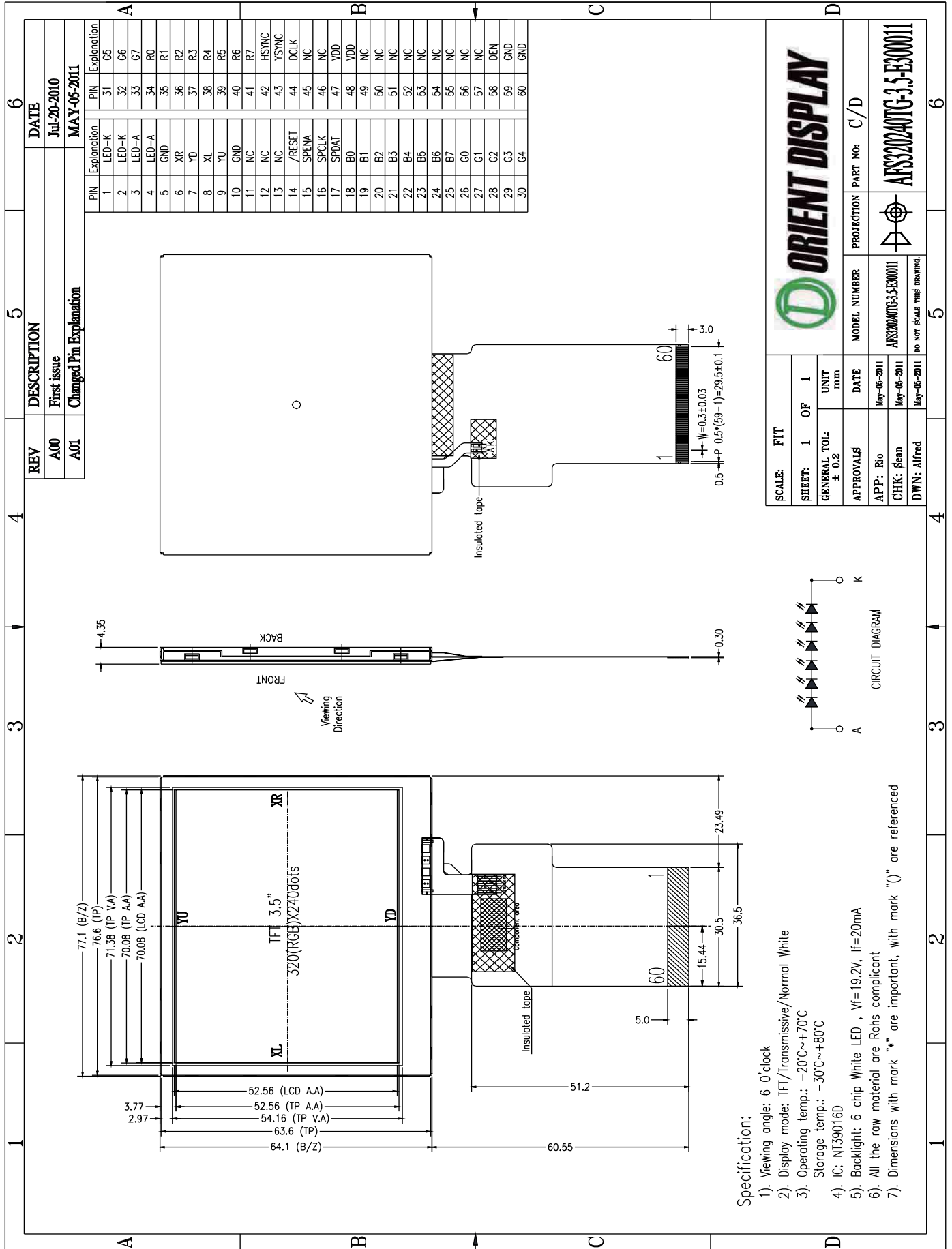

Figure 1. Dimensional outline

3. Block Diagram

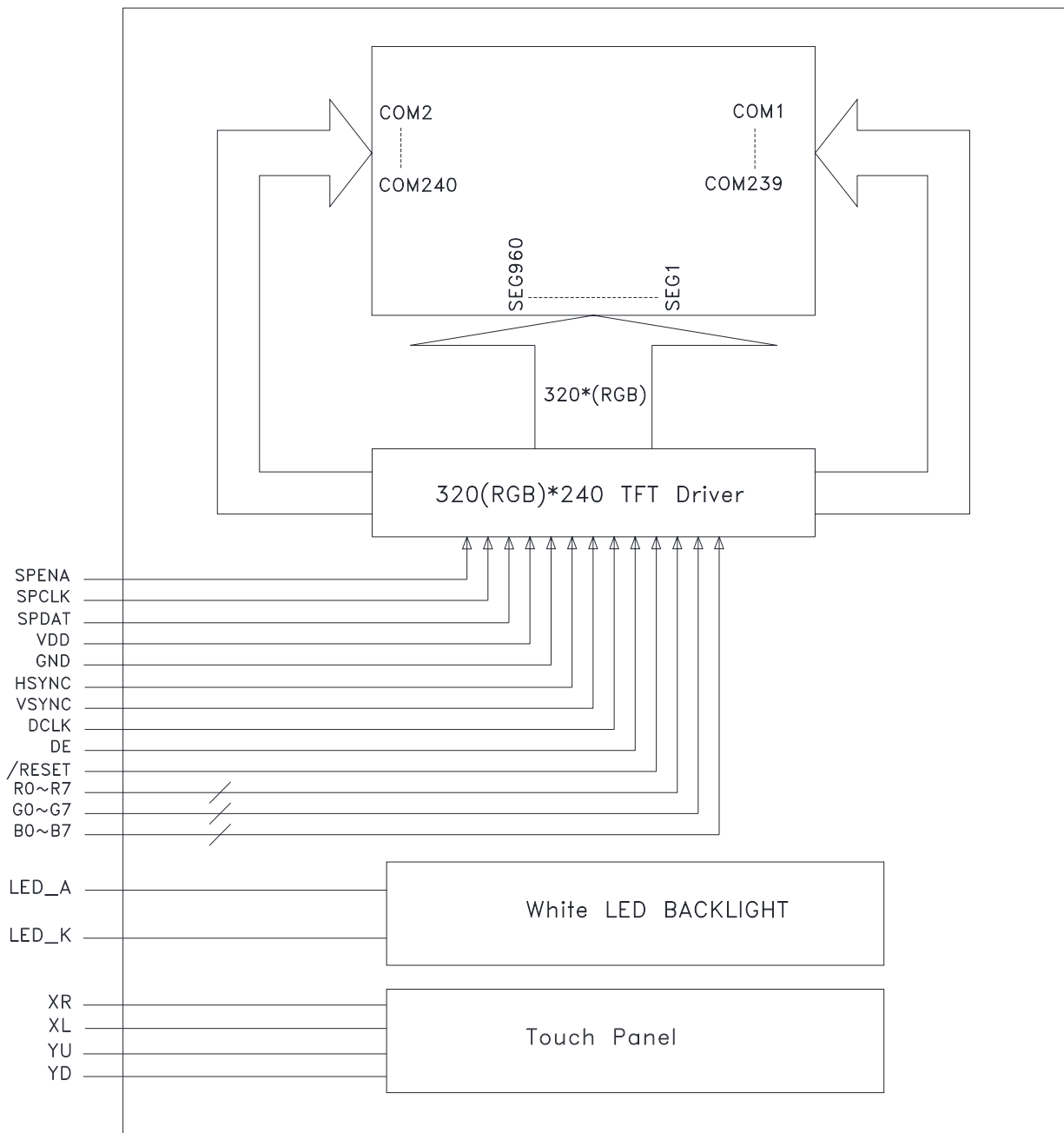

Figure 2. Block diagram

4. Pin Description

PIN No.	SYMBOL	Function
1,2	LED_K	Backlight LED Cathode
3,4	LED_A	Backlight LED Anode
5	GND	Ground
6	XR	Touch Panel XR Position
7	YD	Touch Panel YD Position
8	XL	Touch Panel XL Position
9	YU	Touch Panel YU Position
10	GND	Ground
11,12,13	NC	No Connection
14	/RESET	Reset pin. (Active Low)
15	SPENA	3-Wire Communication Enable. Active Low
16	SPCLK	3-Wire Communication Clock input.
17	SPDAT	3-Wire Communication Data input/output
18~25	B0~B7	B data bus
26~33	G0~G7	G data bus
34~41	R0~R7	R data bus
42	HSYNC	Horizontal Sync input
43	VSYNC	Vertical Sync input
44	DCLK	Clock for Input Data
45,46	NC	No Connection
47,48	VCC	Power supply
49~57	NC	No Connection
58	DEN	Data Input Enable.
59,60	GND	Ground

5. Absolute Maximum Ratings

Item	Symbol	Rating	Unit
Supply Voltage range	VDD	-0.5 to +5.0	V
Operating Temperature range	TOP	-20 to +70	°C
Storage Temperature range	TST	-30 to +80	°C

6. Electrical Characteristics

DC Characteristics

Item	Symbol	Min.	Type.	Max.	Unit
Logic Supply Voltage	VDD	3.0	-	3.6	V

7. Backlight Characteristics

White LED × 6

(Ta = 25°C)

Item	Symbol	Condition	Min	Typ	Max	Unit
Forward Voltage	VF	IF = 20mA	-	19.2	21.6	V
Uniformity	△Bp	-	80	-	-	%
-	Lv	IF = 20mA	3500	4000	-	cd/m ²

8. Electro-Optical Characteristics

Light source: C light

Ta=25°C

Item	Symbol	Condition	Min	Typ.	Max.	Unit	Remark
View Angles	θT	$CR \geq 10$	30	40		Degree	Note 2 With EWV polarizer
	θB		50	60			
	θL		50	60			
	θR		50	60			
Contrast Ratio	CR	$\theta=0^\circ$		350			Note3
Response Time	Ton	25°C		25	40	ms	Note4
	Toff						
Chromaticity	White	X	0.261	0.311	0.361	Measured by C light.	
		Y	0.300	0.350	0.400		
	RED	X	0.586	0.636	0.686		
		Y	0.300	0.350	0.400		
	GREEN	X	0.261	0.311	0.361		
		Y	0.501	0.551	0.601		
	BLUE	X	0.084	0.134	0.184		
		Y	0.101	0.151	0.201		
NTSC				50		%	Note 5
Transmittance			6.9	7.5		%	With EWV polarizer, without DBEF

Rubbing Direction

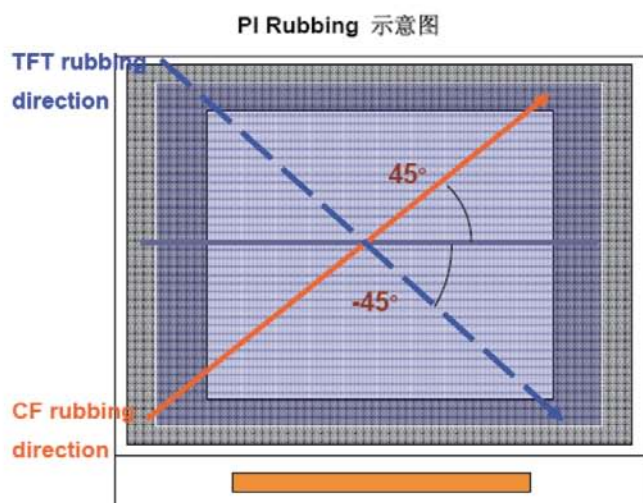

Note 1: Definition of optical measurement system.

The optical characteristics should be measured in dark room. After 5 minutes operation, the optical properties are measured at the center point of the LCD screen. All input terminals LCD panel must be ground when measuring the center area of the panel.

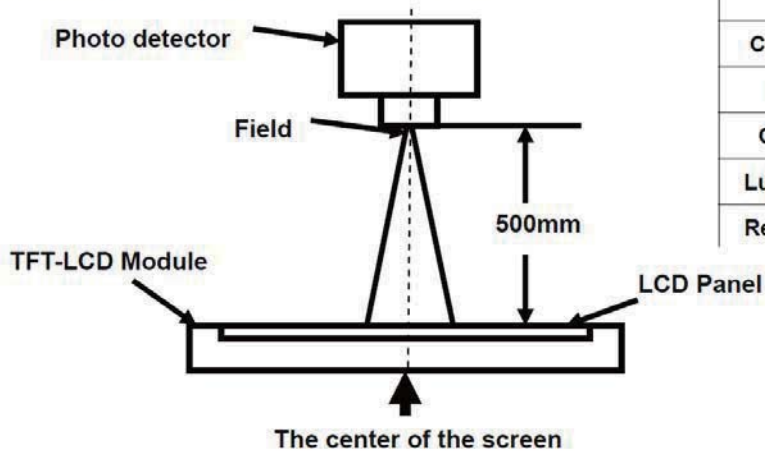

Item	Photo Detector	Field
Contrast Ratio	SR-3	1°
Luminance		
Chromaticity		
Lum Uniformity	BM-7A	2°
Response Time		

Note 2: Definition of viewing angle range and measurement system.

viewing angle is measured at the center point of the LCD by CONOSCOPE(ergo-80).

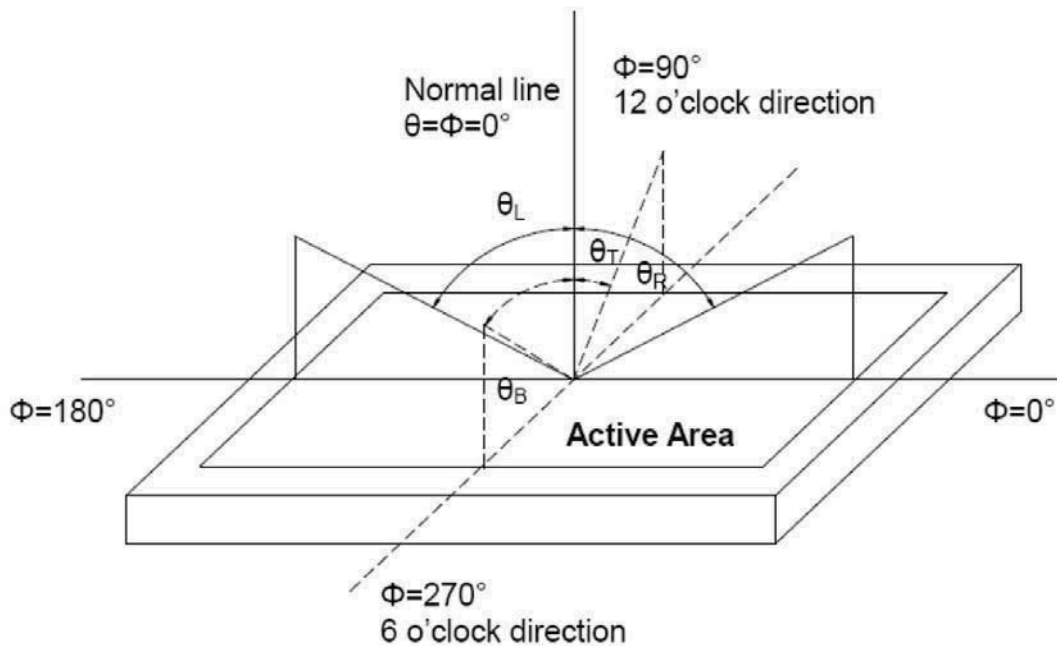

Fig. 1 Definition of viewing angle

Note 3: Definition of contrast ratio

$$\text{Contrast ratio (CR)} = \frac{\text{Luminance measured when LCD is on the "White" state}}{\text{Luminance measured when LCD is on the "Black" state}}$$

"White state ":The state is that the LCD is driven by V_{white} .

"Black state": The state is that the LCD is driven by V_{black} .

V_{white} : To be determined V_{black} : To be determined.

Note 4: Definition of Response time

The response time is defined as the LCD optical switching time interval between "White" state and "Black" state. Rise time (T_{ON}) is the time between photo detector output intensity changed from 90% to 10%. And fall time (T_{OFF}) is the time between photo detector output intensity changed from 10% to 90%.

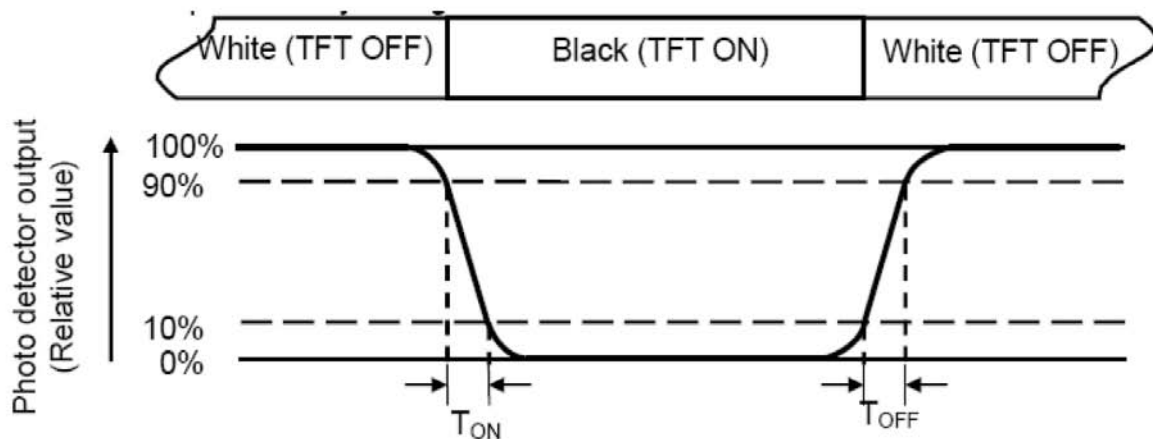

Note 5: Definition of color chromaticity (CIE1931)

Color coordinates measured at center point of LCD.

9. Instruction Description

NT39016 3-Wire Control Register List (Default)

3-Wire Registers		Register Description		
D[15:10]	Name	Init.	R/W	Function Description
000000b	R00	07h	R/W	System control register
000001b	R01	00h	R/W	Timing Controller function register
000010b	R02	03h	R/W	Operation control register
000011b	R03	CCh	R/W	Input data Format control register
000100b	R04	46h	R/W	Source Timing delay control register
000101b	R05	0Dh	R/W	Gate Timing delay control register
000110b	R06	00h	R/W	Reserved
000111b	R07	00h	R/W	Internal function control register
001000b	R08	08h	R/W	RGB Contrast control register
001001b	R09	40h	R/W	RGB Brightness control register
001010b	R0A	88h	R/W	Hue / Saturation control register
001011b	R0B	88h	R/W	R / B Sub-Contrast control register
001100b	R0C	20h	R/W	R Sub-Brightness control register
001101b	R0D	20h	R/W	B Sub-Brightness control register
001110b	R0E	10h	R/W	VCOMDC Level Control Register
001111b	R0F	A4h	R/W	VCOMAC Level Control Register
010000b	R10	04h	R/W	VGAM2 level control register
010001b	R11	24h	R/W	VGAM3/4 level control register
010010b	R12	24h	R/W	VGAM5/6 level control register
011110b	R1E	00h	R/W	VCOMDC Trim function control register
100000b	R20	00h	R/W	Wide and narrow display mode control register

NT39016 3-Wire Register Bit Definition (Default)

3-Wire Control Register Bit Map								
Reg.	Bit [7]	Bit [6]	Bit [5]	Bit [4]	Bit [3]	Bit [2]	Bit [1]	Bit [0]
R00	PAT3	PAT2	PAT1	PAT0	PWMPDB	X	STBYB	RESETB
R01	X	X	X	SWD2	SWD1	SWD0	DITHB	CFTYP
R02	SKIPMOD	HDNC1	HDNC0	X	FPOL	VSET	UPDN	SHLR
R03	DENPOL	CLKPOL	HSDPOL	VSDPOL	SEL3	SEL2	SEL1	SEL0
R04	DDLY7	DDLY6	DDLY5	DDLY4	DDLY3	DDLY2	DDLY1	DDLY0
R05	X	HDLY6	HDLY5	HDLY4	HDLY3	HDLY2	HDLY1	HDLY0
R06	X	X	X	X	X	X	X	X
R07	FRAD1	FRAD0	INVSL1	INVSL0	PAL	PALM	-	AVGY
R08	X	X	X	CON4	CON3	CON2	CON1	CON0
R09	X	BRI6	BRI5	BRI4	BRI3	BRI2	BRI1	BRI0
R0A	HUE3	HUE2	HUE1	HUE0	SAT3	SAT2	SAT1	SAT0
R0B	SCONB1	SCONB0			SCONR1	SCONR0		
R0C	X	X	SBRIR5	SBRIR4	SBRIR3	SBRIR2	SBRIR1	SBRIR0
R0D	X	X	SBRIB5	SBRIB4	SBRIB3	SBRIB2	SBRIB1	SBRIB0
R0E	X	OTP_BYPS	VCDCSL5	VCDCSL4	VCDCSL3	VCDCSL2	VCDCSL1	VCDCSL0
R0F	VGLSL1	VGLSL0	VGHSL1	VGHSL0	VCACSL3	VCACSL2	VCACSL1	VCACSL0
R10	X	X	X	GAMEN	X	V2GAM2	V2GAM1	V2GAM0
R11	X	X	V4GAM2	V4GAM1	V4GAM0	V3GAM2	V3GAM1	V3GAM0
R12	X	X	V6GAM2	V6GAM1	V6GAM0	V5GAM2	V5GAM1	V5GAM0
R1E	TRMEN7	TRMEN6	TRMEN5	TRMEN4	TRMEN3	TRMEN2	TRMEN1	TRMEN0
R20	X	X	X	X	X	X	WNSEL1	WNSEL0

Note: Register function active at the falling edge of VSD except STBYB, RESETB register bits.

10. AC Characteristics

10.1 3-Wire Timing Diagram

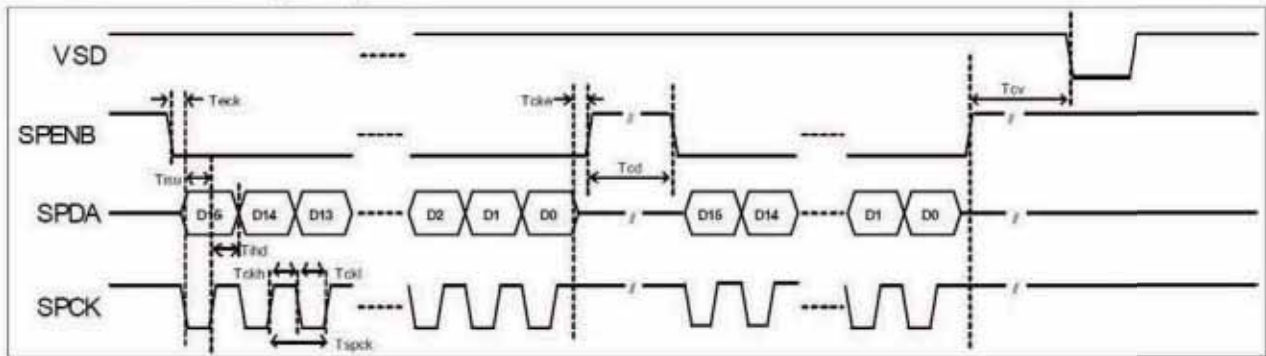

Serial clock	T_{spck}	320	-	-	ns
SPCK pulse duty	T_{scdut}	40	50	60	%
Serial data setup time	T_{tsu}	120	-	-	ns
Serial data hold time	T_{thd}	120	-	-	ns
Serial clock high/low	T_{ssw}	120	-	-	ns
Chip select distinguish	T_{od}	1	-	-	us
SPENA to VSD	T_{cv}	1	-	-	us

3-wire serial communication AC timing

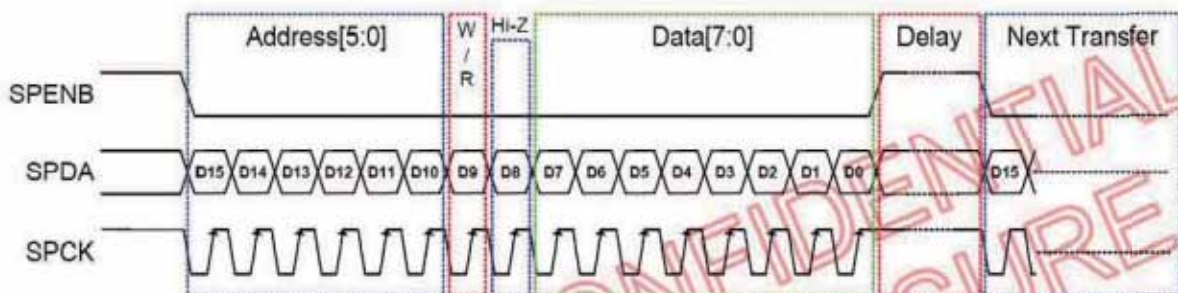

3-Wire Command Format:

Bit	Description
D15-D10	Register Address [5:0].
D9	W/R control bit. "1" for Write, "0" for Read
D8	Hi-Z bit during read mode. Any data within this bits will be ignored during write mode
D7-D0	Data for the W/R operation to the address indicated by Address phase

3-Wire Writer Format:

MSB															LSB
D15	D14	D13	D12	D11	D10	D9	D8	D7	D6	D5	D4	D3	D2	D1	D0
Register Address [5:0]						1	X	DATA (Issue by external controller)							

3-Wire Read Format:

MSB															LSB
D15	D14	D13	D12	D11	D10	D9	D8	D7	D6	D5	D4	D3	D2	D1	D0
Register Address [5:0]						0	Hi-Z	DATA (Issue by NT39016)							

Input Data Timing

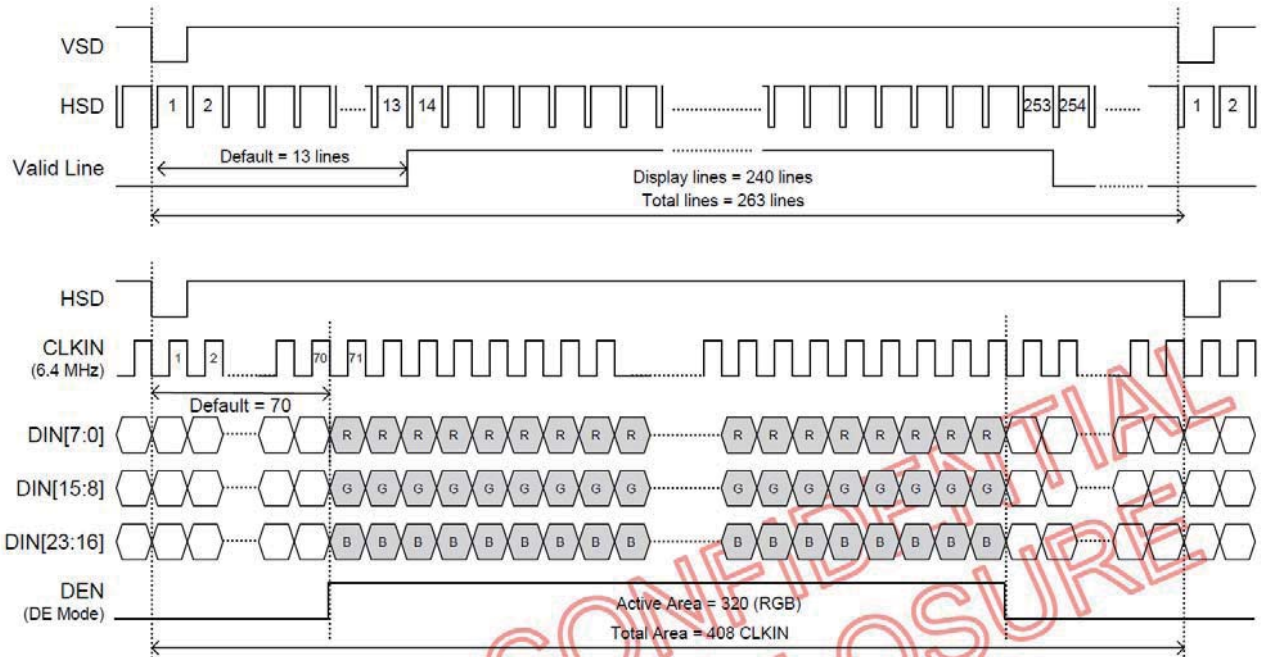

11. Quality Specifications

All The raw material are Rohs complicant.

11.1 Standard of the product appearance test

Manner of appearance test: The inspection should be performed in using 20W x 2 fluorescent lamps. Distance between LCM and fluorescent lamps should be 100 cm or more. Distance between LCM and inspector eyes should be 30 cm or more.

Viewing direction for inspection is 45 ° from vertical against LCM.

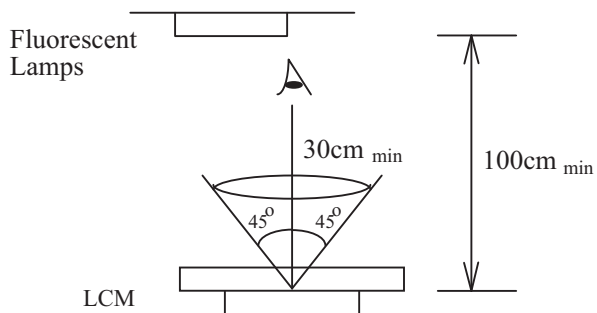

Definition of zone:

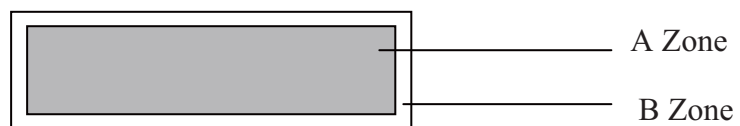

A Zone: viewing area

B Zone: outside viewing area

11.2 Specification of quality assurance

AQL inspection standard

Sampling method: MIL-STD-105E, Level II, single sampling

Defect classification (Note: * is not including)

Classify	Item		Note	AQL
Major	Display state	Short or open circuit	1	0.65
		LC leakage		
		Flickering		
		No display		
		Wrong viewing direction		
		Contrast defect (dim, ghost)	2	
		Back-light	1,8	
	Non-display	Flat cable or pin reverse	10	
Wrong or missing component		11		
Minor	Display state	Background color deviation	2	1.0
		Black spot and dust	3	
		Line defect, Scratch	4	
		Rainbow	5	
		Chip	6	
		Pin hole	7	
	Polarizer	Protruded	12	
		Bubble and foreign material	3	
	Soldering	Poor connection	9	
	Wire	Poor connection	10	
	TAB	Position, Bonding strength	13	

Note on defect classification

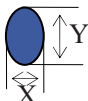
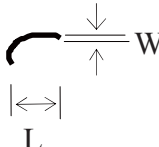
No.	Item	Criterion																				
1	Short or open circuit	Not allow																				
	LC leakage																					
	Flickering																					
	No display																					
	Wrong viewing direction																					
	Wrong Back-light																					
2	Contrast defect	Refer to approval sample																				
	Background color deviation																					
3	Point defect, Black spot, dust (including Polarizer) $\phi = (X+Y)/2$	 <table border="1" data-bbox="917 891 1353 1187"> <thead> <tr> <th>Point Size</th> <th>Acceptable Qty.</th> </tr> </thead> <tbody> <tr> <td>$\phi \leq 0.10$</td> <td>Disregard</td> </tr> <tr> <td>$0.10 < \phi \leq 0.20$</td> <td>3</td> </tr> <tr> <td>$0.20 < \phi \leq 0.25$</td> <td>2</td> </tr> <tr> <td>$0.25 < \phi \leq 0.30$</td> <td>1</td> </tr> <tr> <td>$\phi > 0.30$</td> <td>0</td> </tr> </tbody> </table> <p style="text-align: right;">Unit: mm</p>	Point Size	Acceptable Qty.	$\phi \leq 0.10$	Disregard	$0.10 < \phi \leq 0.20$	3	$0.20 < \phi \leq 0.25$	2	$0.25 < \phi \leq 0.30$	1	$\phi > 0.30$	0								
Point Size	Acceptable Qty.																					
$\phi \leq 0.10$	Disregard																					
$0.10 < \phi \leq 0.20$	3																					
$0.20 < \phi \leq 0.25$	2																					
$0.25 < \phi \leq 0.30$	1																					
$\phi > 0.30$	0																					
4	Line defect, Scratch	 <table border="1" data-bbox="845 1361 1396 1624"> <thead> <tr> <th colspan="2">Line</th> <th>Acceptable Qty.</th> </tr> <tr> <th>L</th> <th>W</th> <th></th> </tr> </thead> <tbody> <tr> <td>---</td> <td>$0.015 \geq W$</td> <td>Disregard</td> </tr> <tr> <td>$3.0 \geq L$</td> <td>$0.03 \geq W$</td> <td rowspan="2">2</td> </tr> <tr> <td>$2.0 \geq L$</td> <td>$0.05 \geq W$</td> </tr> <tr> <td>$1.0 \geq L$</td> <td>$0.1 > W$</td> <td>1</td> </tr> <tr> <td>---</td> <td>$0.05 < W$</td> <td>Applied as point defect</td> </tr> </tbody> </table> <p style="text-align: right;">Unit: mm</p>	Line		Acceptable Qty.	L	W		---	$0.015 \geq W$	Disregard	$3.0 \geq L$	$0.03 \geq W$	2	$2.0 \geq L$	$0.05 \geq W$	$1.0 \geq L$	$0.1 > W$	1	---	$0.05 < W$	Applied as point defect
Line		Acceptable Qty.																				
L	W																					
---	$0.015 \geq W$	Disregard																				
$3.0 \geq L$	$0.03 \geq W$	2																				
$2.0 \geq L$	$0.05 \geq W$																					
$1.0 \geq L$	$0.1 > W$	1																				
---	$0.05 < W$	Applied as point defect																				
5	Rainbow	Not more than two color changes across the viewing area.																				

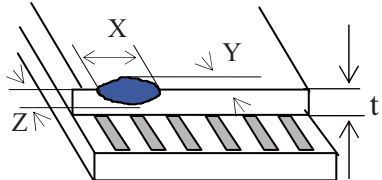
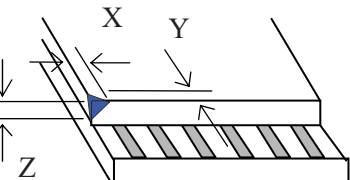
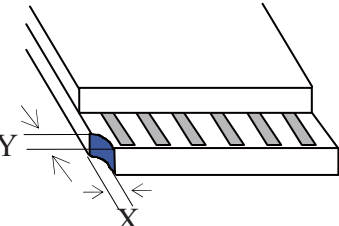
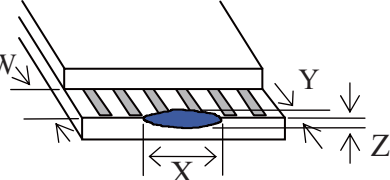
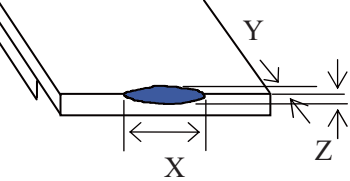
No	Item	Criterion																																	
6	<p data-bbox="268 342 331 376">Chip</p> <p data-bbox="268 450 379 483">Remark:</p> <p data-bbox="323 488 459 555">X: Length direction</p> <p data-bbox="323 577 459 645">Y: Short direction</p> <p data-bbox="323 667 496 734">Z: Thickness direction</p> <p data-bbox="323 757 485 824">t: Glass thickness</p> <p data-bbox="323 846 491 913">W: Terminal Width</p>	<div data-bbox="587 387 970 566">  </div> <p data-bbox="991 376 1257 409">Acceptable criterion</p> <table border="1" data-bbox="991 421 1382 499"> <thead> <tr> <th>X</th> <th>Y</th> <th>Z</th> </tr> </thead> <tbody> <tr> <td>≤ 2</td> <td>0.5mm</td> <td>$\leq t/2$</td> </tr> </tbody> </table> <div data-bbox="587 701 938 880">  </div> <p data-bbox="978 689 1244 723">Acceptable criterion</p> <table border="1" data-bbox="978 734 1382 813"> <thead> <tr> <th>X</th> <th>Y</th> <th>Z</th> </tr> </thead> <tbody> <tr> <td>≤ 2</td> <td>0.5mm</td> <td>$\leq t$</td> </tr> </tbody> </table> <div data-bbox="587 969 927 1193">  </div> <p data-bbox="991 981 1262 1014">Acceptable criterion</p> <table border="1" data-bbox="991 1025 1382 1137"> <thead> <tr> <th>X</th> <th>Y</th> <th>Z</th> </tr> </thead> <tbody> <tr> <td>≤ 3</td> <td>≤ 2</td> <td>$\leq t$</td> </tr> <tr> <td colspan="2">shall not reach to ITO</td> <td></td> </tr> </tbody> </table> <div data-bbox="587 1328 978 1507">  </div> <p data-bbox="978 1361 1246 1395">Acceptable criterion</p> <table border="1" data-bbox="978 1406 1382 1485"> <thead> <tr> <th>X</th> <th>Y</th> <th>Z</th> </tr> </thead> <tbody> <tr> <td>Disregard</td> <td>≤ 0.2</td> <td>$\leq t$</td> </tr> </tbody> </table> <div data-bbox="587 1641 938 1821">  </div> <p data-bbox="978 1653 1246 1686">Acceptable criterion</p> <table border="1" data-bbox="978 1697 1350 1765"> <thead> <tr> <th>X</th> <th>Y</th> <th>Z</th> </tr> </thead> <tbody> <tr> <td>≤ 5</td> <td>≤ 2</td> <td>$\leq t/3$</td> </tr> </tbody> </table>	X	Y	Z	≤ 2	0.5mm	$\leq t/2$	X	Y	Z	≤ 2	0.5mm	$\leq t$	X	Y	Z	≤ 3	≤ 2	$\leq t$	shall not reach to ITO			X	Y	Z	Disregard	≤ 0.2	$\leq t$	X	Y	Z	≤ 5	≤ 2	$\leq t/3$
X	Y	Z																																	
≤ 2	0.5mm	$\leq t/2$																																	
X	Y	Z																																	
≤ 2	0.5mm	$\leq t$																																	
X	Y	Z																																	
≤ 3	≤ 2	$\leq t$																																	
shall not reach to ITO																																			
X	Y	Z																																	
Disregard	≤ 0.2	$\leq t$																																	
X	Y	Z																																	
≤ 5	≤ 2	$\leq t/3$																																	

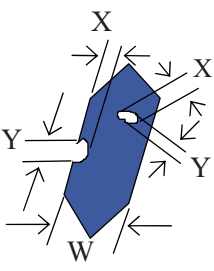
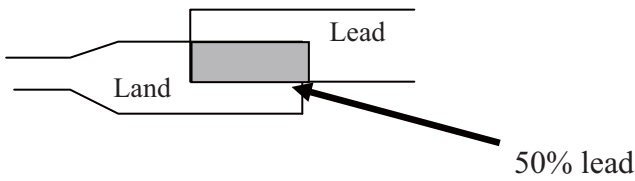
No.	Item	Criterion								
7	Segment pattern W = Segment width $\phi = (X+Y)/2$	<p>(1) Pin hole</p> <p>$\phi < 0.10\text{mm}$ is acceptable.</p>  <table border="1" data-bbox="909 548 1364 728"> <thead> <tr> <th>Point Size</th> <th>Acceptable Qty</th> </tr> </thead> <tbody> <tr> <td>$\phi \leq 1/4W$</td> <td>Disregard</td> </tr> <tr> <td>$1/4W < \phi \leq 1/2W$</td> <td>1</td> </tr> <tr> <td>$\phi > 1/2W$</td> <td>0</td> </tr> </tbody> </table> <p>Unit: mm</p>	Point Size	Acceptable Qty	$\phi \leq 1/4W$	Disregard	$1/4W < \phi \leq 1/2W$	1	$\phi > 1/2W$	0
Point Size	Acceptable Qty									
$\phi \leq 1/4W$	Disregard									
$1/4W < \phi \leq 1/2W$	1									
$\phi > 1/2W$	0									
8	Back-light	<p>(1) The color of backlight should correspond its specification.</p> <p>(2) Not allow flickering</p>								
9	Soldering	<p>(1) Not allow heavy dirty and solder ball on PCB. (The size of dirty refer to point and dust defect)</p> <p>(2) Over 50% of lead should be soldered on Land.</p> 								
10	Wire	<p>(1) Copper wire should not be rusted</p> <p>(2) Not allow crack on copper wire connection.</p> <p>(3) Not allow reversing the position of the flat cable.</p> <p>(4) Not allow exposed copper wire inside the flat cable.</p>								
11*	PCB	<p>(1) Not allow screw rust or damage.</p> <p>(2) Not allow missing or wrong putting of component.</p>								

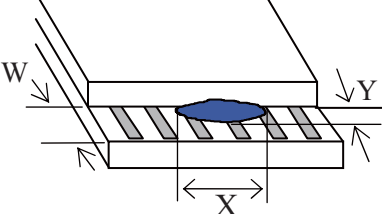
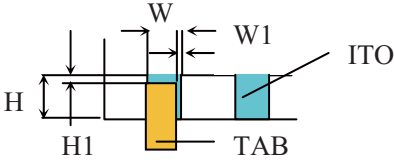
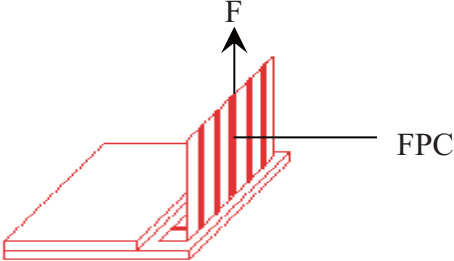
No	Item	Criterion
12	Protruded W: Terminal Width	 <p>Acceptable criteria: $Y \leq 0.4$</p>
13	TAB	<p>1. Position</p>  <div style="border: 1px solid black; padding: 5px; width: fit-content; margin-left: auto; margin-right: auto;"> $W1 \leq 1/3W$ $H1 \leq 1/3H$ </div> <p>2 FPC bonding strength test</p>  <p> $P (=F/FPC \text{ bonding width}) \geq 650\text{gf/cm}$,(speed rate: 1mm/min) 5pcs per SOA (shipment) </p>
14	Total no. of acceptable Defect	<p>A. Zone</p> <p>Maximum 2 minor non-conformities per one unit. Defect distance: each point to be separated over 10mm</p> <p>B. Zone</p> <p>It is acceptable when it is no trouble for quality and assembly in customer's end product.</p>

11.3 Reliability of LCM

Reliability test condition:

Item	Condition	Time (hrs)	Assessment
High temp. Storage	60°C	48	No abnormalities in functions and appearance
High temp. Operating	50°C	48	
Low temp. Storage	-20°C	48	
Low temp. Operating	-10°C	48	
Humidity	40°C/ 90%RH	48	
Temp. Cycle	-20°C ← 25°C →60°C (60 min ← 5 min → 60min)	10cycles	

Recovery time should be 24 hours minimum. Moreover, functions, performance and appearance shall be free from remarkable deterioration within 50,000 hours under ordinary operating and storage conditions room temperature ($20\pm 8^{\circ}\text{C}$), normal humidity (below 65% RH), and in the area not exposed to direct sun light.

11.4 Precaution for using LCD/LCM

LCD/LCM is assembled and adjusted with a high degree of precision. Do not attempt to make any alteration or modification. The followings should be noted.

General Precautions:

1. LCD panel is made of glass. Avoid excessive mechanical shock or applying strong pressure onto the surface of display area.
2. The polarizer used on the display surface is easily scratched and damaged. Extreme care should be taken when handling. To clean dust or dirt off the display surface, wipe gently with cotton, or other soft material soaked with isopropyl alcohol, ethyl alcohol or trichlorotrifluoroethane, do not use water, ketone or aromatics and never scrub hard.
3. Do not tamper in any way with the tabs on the metal frame.
4. Do not make any modification on the PCB without consulting Orient Display.
5. When mounting a LCM, make sure that the PCB is not under any stress such as bending or twisting. Elastomer contacts are very delicate and missing pixels could result from slight dislocation of any of the elements.
6. Avoid pressing on the metal bezel, otherwise the elastomer connector could be deformed and lose contact, resulting in missing pixels and also cause rainbow on the display.
7. Be careful not to touch or swallow liquid crystal that might leak from a damaged cell. Any liquid crystal adheres to skin or clothes, wash it off immediately with soap and water.

Static Electricity Precautions:

1. CMOS-LSI is used for the module circuit; therefore operators should be grounded whenever he/she comes into contact with the module.
2. Do not touch any of the conductive parts such as the LSI pads; the copper leads on the PCB and the interface terminals with any parts of the human body.
3. Do not touch the connection terminals of the display with bare hand; it will cause disconnection or defective insulation of terminals.
4. The modules should be kept in anti-static bags or other containers resistant to static for storage.
5. Only properly grounded soldering irons should be used.
6. If an electric screwdriver is used, it should be grounded and shielded to prevent sparks.
7. The normal static prevention measures should be observed for work clothes and working benches.
8. Since dry air is inductive to static, a relative humidity of 50-60% is recommended.

Soldering Precautions:

1. Soldering should be performed only on the I/O terminals.
2. Use soldering irons with proper grounding and no leakage.
3. Soldering temperature: $280^{\circ}\text{C} \pm 10^{\circ}\text{C}$
4. Soldering time: 3 to 4 second.
5. Use eutectic solder with resin flux filling.
6. If flux is used, the LCD surface should be protected to avoid spattering flux.
7. Flux residue should be removed.

Operation Precautions:

1. The viewing angle can be adjusted by varying the LCD driving voltage V_o .
2. Since applied DC voltage causes electro-chemical reactions, which deteriorate the display, the applied pulse waveform should be a symmetric waveform such that no DC component remains. Be sure to use the specified operating voltage.
3. Driving voltage should be kept within specified range; excess voltage will shorten display life.
4. Response time increases with decrease in temperature.
5. Display color may be affected at temperatures above its operational range.
6. Keep the temperature within the specified range usage and storage. Excessive temperature and humidity could cause polarization degradation, polarizer peel-off or generate bubbles.
7. For long-term storage over 40°C is required, the relative humidity should be kept below 60%, and avoid direct sunlight.

Limited Warranty

Orient Display's LCDs and modules are not consumer products, but may be incorporated by Orient Display's customers into consumer products or components thereof, Orient Display does not warrant that its LCDs and components are fit for any such particular purpose.

1. The liability of Orient Display is limited to repair or replacement on the terms set forth below. Orient Display will not be responsible for any subsequent or consequential events or injury or damage to any personnel or user including third party personnel and/or user. Unless otherwise agreed in writing between Orient Display and the customer, Orient Display will only replace or repair any of its LCD which is found defective electrically or visually when inspected in accordance with Orient Display general LCD inspection standard. (Copies available on request)
2. No warranty can be granted if any of the precautions state in handling liquid crystal display above has been disregarded. Broken glass, scratches on polarizer mechanical damages as well as defects that are caused accelerated environment tests are excluded from warranty.
3. In returning the LCD/LCM, they must be properly packaged; there should be detailed description of the failures or defect.