



**SPECIFICATION
FOR
LCD MODULE**

**MODULE NO: AFU800600G-10.4-SN02V2
REVISION NO: 00**

Customer's Approval:

| |
|--|
| |
|--|

| | SIGNATURE | DATE |
|---------------------------|-----------|----------|
| PREPARED BY (RD ENGINEER) | | 2009-2-3 |
| CHECKED BY | | |
| APPROVED BY | | |

Contents

| | |
|---|----------|
| 1. Operating Precautions | 4 |
| 2. General Description | 5 |
| 2.1 Display Characteristics | 5 |
| 2.2 Optical Characteristics..... | 6 |
| 3. Functional Block Diagram | 9 |
| 4. Absolute Maximum Ratings | 9 |
| 4.1 Absolute Ratings of TFT LCD Module | 9 |
| 4.2 Absolute Ratings of Environment..... | 9 |
| 5. Electrical Characteristics | 9 |
| 5.1 TFT LCD Module | 9 |
| 5.2 Backlight Unit..... | 9 |
| 6. Signal Characteristics | 9 |
| 6.1 Pixel Format Image | 9 |
| 6.2 Scanning Direction..... | 9 |
| 6.3 TFT-LCD Interface Signal Description | 9 |
| 6.4 The Input Data Format..... | 9 |
| 6.5 TFT-LCD Interface Timing..... | 9 |
| 6.6 Power ON/OFF Sequence | 9 |
| 7. Connector & Pin Assignment | 9 |
| 7.1 TFT-LCD Signal (CN1): LCD Connector..... | 9 |
| 7.2 LED Backlight Unit (CN2): Backlight Connector | 9 |
| 8. Reliability Test Criteria | 9 |
| 9. Mechanical Characteristics | 9 |
| 9.1 LCM Outline Dimension (Front View) | 9 |
| 9.2 LCM Outline Dimension (Rear View)..... | 9 |
| 10. Label and Packaging | 9 |
| 10.1 Shipping Label (on the rear side of TFT-LCD display) | 9 |
| 10.2 Carton Package | 9 |
| 11 Safety | 9 |
| 11.1 Sharp Edge Requirements | 9 |
| 11.2 Materials | 9 |
| 11.3 Capacitors | 9 |
| 11.4 National Test Lab Requirement..... | 9 |

| Version and Date | Page | Old description | New Description |
|-------------------------|-------------|------------------------|------------------------|
| 0.0 2009/02/03 | All | First Edition | |
| | | | |
| | | | |
| | | | |
| | | | |
| | | | |
| | | | |
| | | | |
| | | | |
| | | | |
| | | | |
| | | | |
| | | | |
| | | | |

1. Operating Precautions

- 1) Since front polarizer is easily damaged, please be cautious and not to scratch it.
- 2) Be sure to turn off power supply when inserting or disconnecting from input connector.
- 3) Wipe off water drop immediately. Long contact with water may cause discoloration or spots.
- 4) When the panel surface is soiled, wipe it with absorbent cotton or soft cloth.
- 5) Since the panel is made of glass, it may be broken or cracked if dropped or bumped on hard surface.
- 6) To avoid ESD (Electro Static Discharge) damage, be sure to ground yourself before handling TFT-LCD Module.
- 7) Do not open nor modify the module assembly.
- 8) Do not press the reflector sheet at the back of the module to any direction.
- 9) In case if a module has to be put back into the packing container slot after it was taken out from the container, do not press the center of the LED light bar edge. Instead, press at the far ends of the LED light bar edge softly. Otherwise the TFT Module may be damaged.
- 10) At the insertion or removal of the Signal Interface Connector, be sure not to rotate nor tilt the Interface Connector of the TFT Module.
- 11) TFT-LCD Module is not allowed to be twisted & bent even force is added on module in a very short time. Please design your display product well to avoid external force applying to module by end-user directly.
- 12) Small amount of materials without flammability grade are used in the TFT-LCD module. The TFT-LCD module should be supplied by power complied with requirements of Limited Power Source (IEC60950 or UL1950), or be applied exemption.
- 13) Severe temperature condition may result in different luminance, response time and lamp ignition voltage.
- 14) Continuous operating TFT-LCD display under low temperature environment may accelerate lamp exhaustion and reduce luminance dramatically.
- 15) The data on this specification sheet is applicable when LCD module is placed in landscape position.
- 16) Continuous displaying fixed pattern may induce image sticking. It's recommended to use screen saver or shuffle content periodically if fixed pattern is displayed on the screen.

2. General Description

This specification applies to the Color Active Matrix Liquid Crystal Display AMU800600SN02-10.4-V2 composed of a TFT-LCD display, a driver and power supply circuit, and a LED backlight system.

The screen format is intended to support SVGA (800(H) x 600(V)) screen and 16.2M (RGB 8-bits) or 262k colors (RGB 6-bits).

LED driving board for backlight unit is included in AMU800600SN02-10.4-V2 and the LED unit is replaceable.

All input signals are LVDS interface.

AMU800600SN02-10.4-V2 designed with wide viewing angle; wide temperature and long life LED backlight is well suited for industrial applications.

AMU800600SN02-10.4-V2 is a RoHS product.

2.1 Display Characteristics

The following items are characteristics summary on the table under 25 °C condition:

| Items | Unit | Specifications |
|---------------------------|---------|------------------------------------|
| Screen Diagonal | [inch] | 10.4 |
| Active Area | [mm] | 211.2 (H) x 158.4 (V) |
| Pixels H x V | | 800 x 3(RGB) x 600 |
| Pixel Pitch | [mm] | 0.264 x 0.264 |
| Pixel Arrangement | | R.G.B. Vertical Stripe |
| Display Mode | | TN, Normally White |
| Nominal Input Voltage VDD | [Volt] | 3.3 (typ.) |
| Typical Power Consumption | [Watt] | 5.2W All black pattern |
| Weight | [Grams] | 360(Typ.) |
| Physical Size | [mm] | 243.0(H) x 184.0(V) x 8.0(D)(Typ.) |
| Electrical Interface | | 1 channel LVDS |
| Surface Treatment | | Anti-glare, Hardness 3H |
| Support Color | | 16.2M / 262K colors |
| Temperature Range | | |
| Operating | [°C] | -30 to +85 |
| Storage (Non-Operating) | [°C] | -30 to +85 |
| RoHS Compliance | | RoHS Compliance |

2.2 Optical Characteristics

The optical characteristics are measured under stable conditions at 25°C (Room Temperature):

| Item | Unit | Conditions | Min. | Typ. | Max. | Remark |
|---|----------------------|---|------|------|------|-----------|
| White Luminance | [cd/m ²] | I _F = 80mA/1 LED Line (center point) | 300 | 400 | - | Note 1 |
| Uniformity | % | 5 Points | 75 | - | - | Note 2, 3 |
| Contrast Ratio | | | 500 | 700 | - | Note 4 |
| Response Time | [msec] | Rising | - | 10 | 20 | Note 5 |
| | [msec] | Falling | - | 20 | 30 | |
| | [msec] | Raising + Falling | - | 30 | 50 | |
| Viewing Angle | [degree] | Horizontal (Right) CR = 10 (Left) | 70 | 80 | - | Note 6 |
| | [degree] | | 70 | 80 | - | |
| | [degree] | Vertical (Upper) CR = 10 (Lower) | 50 | 60 | - | |
| | [degree] | | 70 | 80 | - | |
| Color / Chromaticity Coordinates (CIE 1931) | | Red x | TBD | TBD | TBD | |
| | | Red y | TBD | TBD | TBD | |
| | | Green x | TBD | TBD | TBD | |
| | | Green y | TBD | TBD | TBD | |
| | | Blue x | TBD | TBD | TBD | |
| | | Blue y | TBD | TBD | TBD | |
| | | White x | 0.26 | 0.31 | 0.36 | |
| | | White y | 0.28 | 0.33 | 0.38 | |
| Color Gamut | % | | - | 45 | - | |

Note 1: Measurement method

Equipment Pattern Generator, Power Supply, Digital Voltmeter, Luminance meter (SR_3 or equivalent)

Aperture 1° with 50cm viewing distance

Test Point Center

Environment < 1 lux

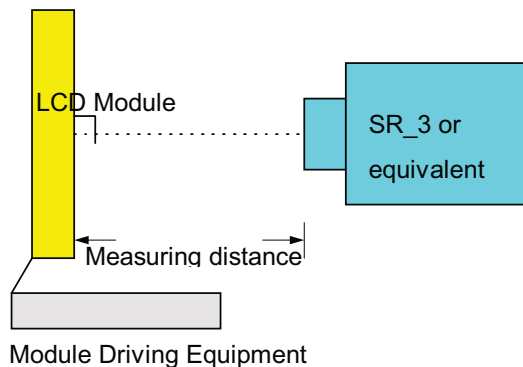

Note 2: Definition of 5 points position (Display active area: 211.2mm (H) x 158.4mm (V))

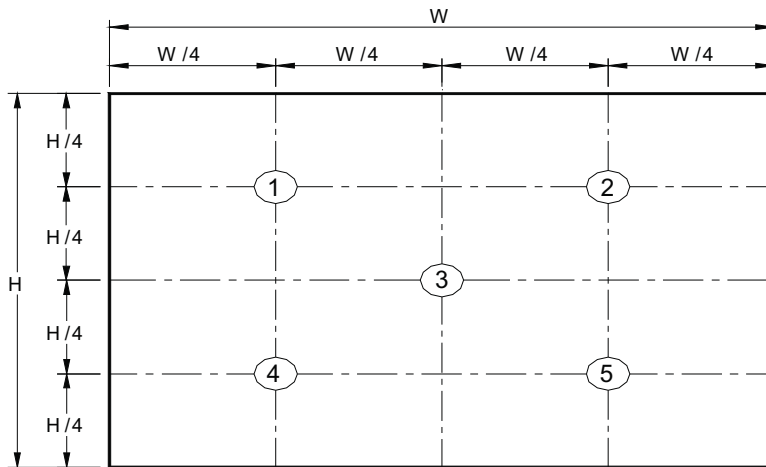

Note 3: The luminance uniformity of 5 points is defined by dividing the minimum luminance values by the maximum test point luminance

$$\delta_{w9} = \frac{\text{Minimum Brightness of five points}}{\text{Maximum Brightness of five points}}$$

Note 4: Definition of contrast ratio (CR):

$$\text{Contrast ratio (CR)} = \frac{\text{Brightness on the "White" state}}{\text{Brightness on the "Black" state}}$$

Note 5: Definition of response time:

The output signals of photo detector are measured when the input signals are changed from "White" to "Black" (falling time) and from "Black" to "White" (rising time), respectively. The response time interval is between 10% and 90% of amplitudes. Please refer to the figure as below.

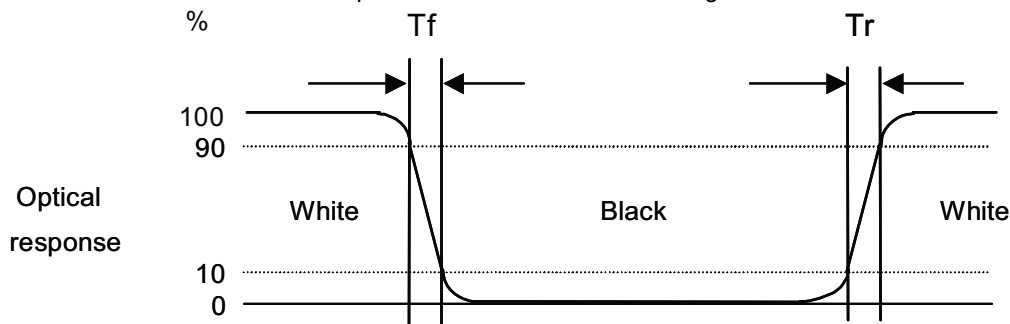

Note 6: Definition of viewing angle

Viewing angle is the measurement of contrast ratio ≥ 10 , at the screen center, over a 180° horizontal and 180° vertical range (off-normal viewing angles). The 180° viewing angle range is broken down as below: 90° (θ) horizontal left and right, and 90° (Φ) vertical high (up) and low (down). The measurement direction is typically perpendicular to the display surface with the screen rotated to its center to develop

the desired measurement viewing angle.

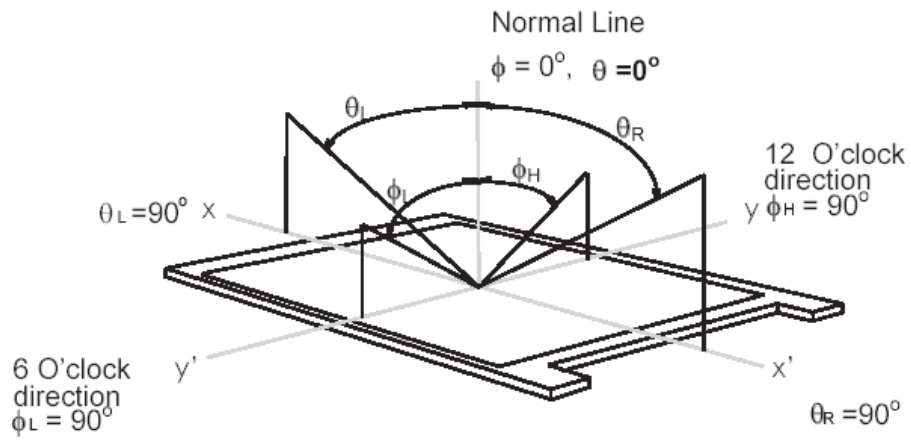

3. Functional Block Diagram

The following diagram shows the functional block of the 10.4 inch color TFT/LCD module:

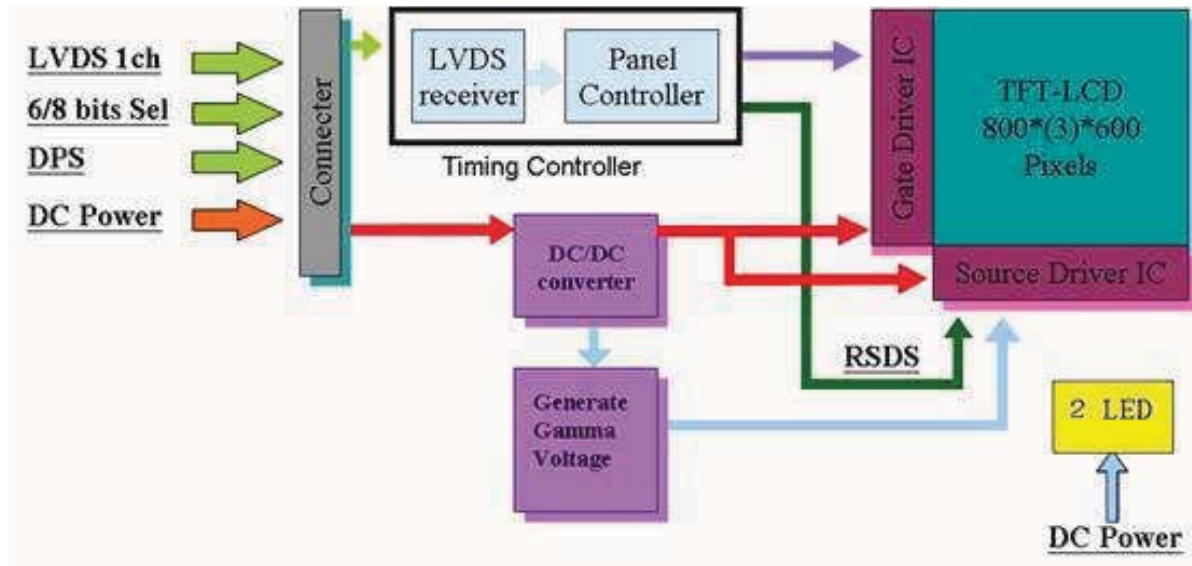

4. Absolute Maximum Ratings

4.1 Absolute Ratings of TFT LCD Module

| Item | Symbol | Min | Max | Unit |
|-----------------|--------|------|------|--------|
| Logic/LCD Drive | Vin | -0.3 | +4.0 | [Volt] |

4.2 Absolute Ratings of Environment

| Item | Symbol | Min | Max | Unit |
|-----------------------|--------|-----|-----|-------|
| Operating Temperature | TOP | -30 | +85 | [°C] |
| Operation Humidity | HOP | 5 | 95 | [%RH] |
| Storage Temperature | TST | -30 | +85 | [°C] |
| Storage Humidity | HST | 5 | 95 | [%RH] |

Note: Maximum Wet-Bulb should be 39°C and no condensation.

5. Electrical Characteristics

5.1 TFT LCD Module

5.1.1 Power Specification

| Symbol | Parameter | Min | Typ | Max | Units | Remark |
|-----------------------|--|-----|-------|-----|-------------|--|
| VDD | Logic/LCD Input Voltage | 3.0 | 3.3 | 3.6 | [Volt] | |
| I _{VDD} | LCD Input Current | - | 280 | - | [mA] | VDD=3.3V at 60 HZ, all Black Pattern |
| P _{VDD} | LCD Power consumption | - | 0.924 | - | [Watt] | VDD=3.3V at 60 HZ, all Black Pattern |
| I _{rush LCD} | LCD Inrush Current | - | - | 1.5 | [A] | Note 1; VDD=3.3V Black Pattern, Rising time=470us |
| VDD _{rp} | Allowable Logic/LCD Drive Ripple Voltage | - | - | 100 | [mV] p-p | VDD=3.3V at 60 HZ, all Black Pattern |

Note 1: Measurement condition:

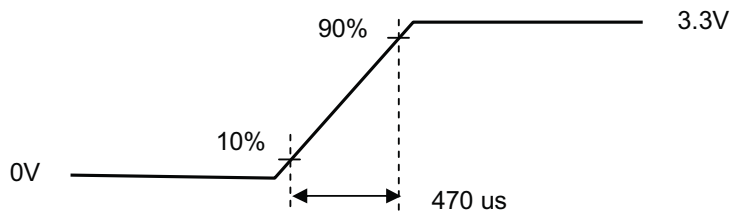
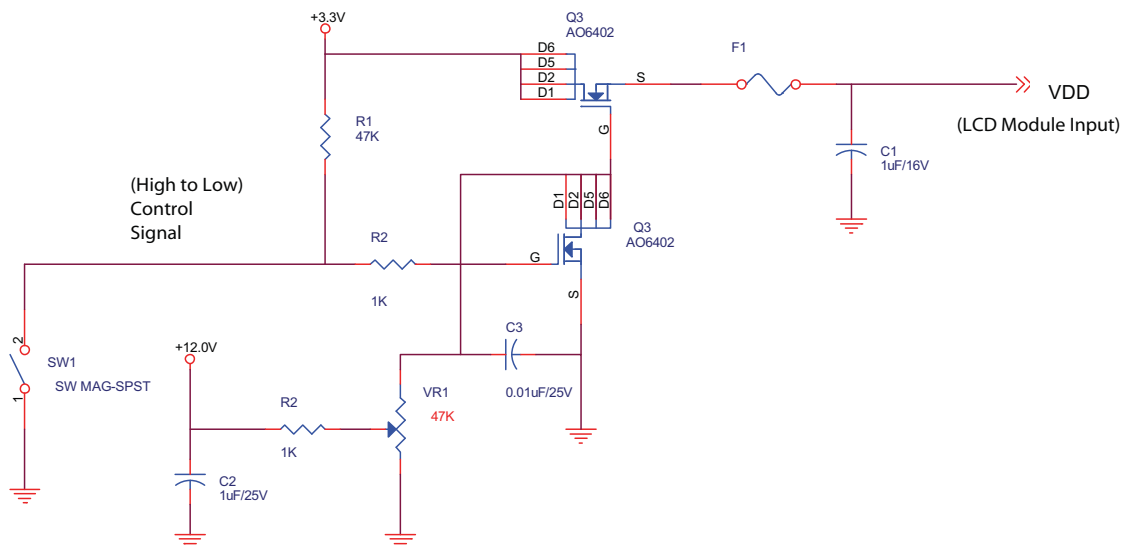

VDD rising time

5.1.2 Signal Electrical Characteristics

Input signals shall be low or Hi-Z state when VDD is off.

| Symbol | Item | Min. | Typ. | Max. | Unit | Remark |
|--------|--|------|------|------|------|-----------------|
| VTH | Differential Input High Threshold | - | - | 100 | [mV] | VCM=1.2V |
| VTL | Differential Input Low Threshold | 100 | - | - | [mV] | VCM=1.2V |
| VID | Input Differential Voltage | 100 | 400 | 600 | [mV] | |
| VICM | Differential Input Common Mode Voltage | 1.1 | - | 1.45 | [V] | VTH/VTL=+-100mV |

Note: LVDS Signal Waveform.

Single-end Signal

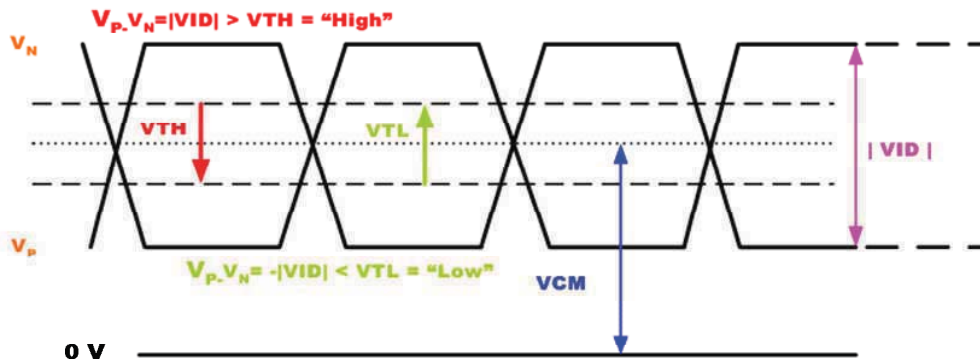

Differential Signal

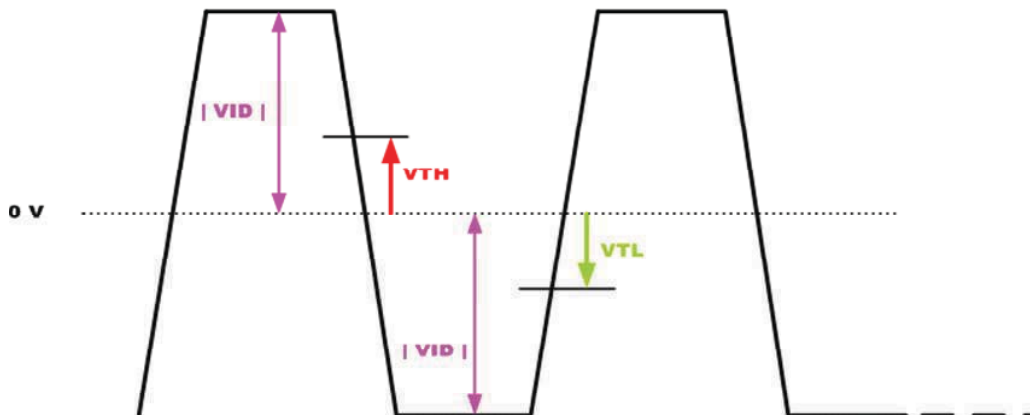

5.2 Backlight Unit

5.2.1 Parameter guideline for LED backlight

Following characteristics are measured under a stable condition using a inverter at 25°C. (Room Temperature):

| Symbol | Parameter | Min. | Typ. | Max. | Unit | Remark |
|-----------------------|--------------------|--------|------|------|--------|---|
| VCC | Input Voltage | 10.8 | 12 | 12.6 | [Volt] | |
| I _{VCC} | Input Current | - | 0.35 | - | [A] | 100% PWM Duty |
| P _{VCC} | Power Consumption | - | 4.2 | TBD | [Watt] | 100% PWM Duty |
| I _{rush LED} | Inrush Current | - | - | TBD | [A] | at rising time=470us |
| F _{PWM} | Dimming Frequency | 200 | - | 20K | [Hz] | |
| | Swing Voltage | 3 | 3.3 | 5.5 | [Volt] | |
| | Dimmung duty cycle | TBD | - | 100 | % | |
| Operation Life | | 50,000 | - | - | Hrs | I _F =80mA, T _a = 25°C |

Note 1: T_a means ambient temperature of TFT-LCD module.

Note 2: I_F means LED unit forward current.

Note 3: VCC, I_{VCC}, I_{rush LED}, P_{VCC} are defined for LED backlight.(100% duty of PWM dimming)

Note 4: If AMU800600SN02-10.4-V2 module is driven by high current or at high ambient temperature & humidity condition. The operating life will be reduced.

Note 5: Operating life means brightness goes down to 50% initial brightness. Minimum operating life time is estimated data.

6. Signal Characteristics

6.1 Pixel Format Image

Following figure shows the relationship between input signal and LCD pixel format.

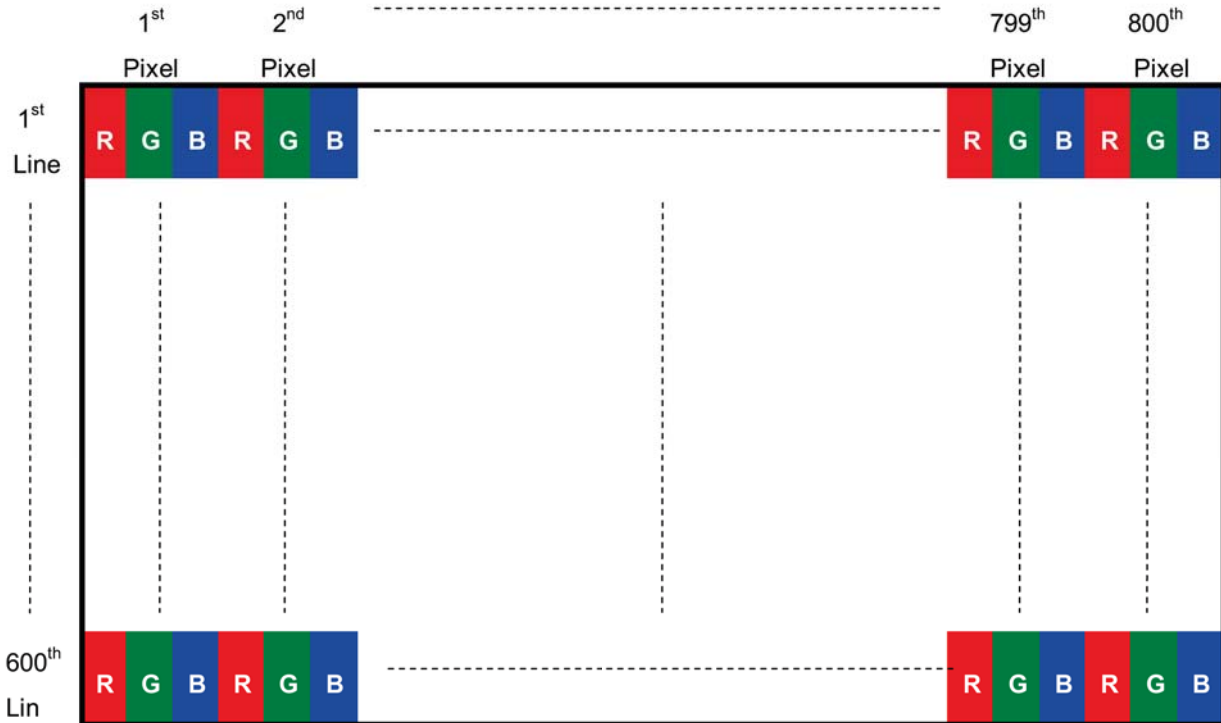

6.2 Scanning Direction

The following figures show the image seen from the front view. The arrow indicates the direction of scan.

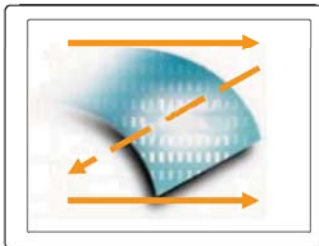

Fig. 1 Normal scan (Pin19, RSV = Low or NC)

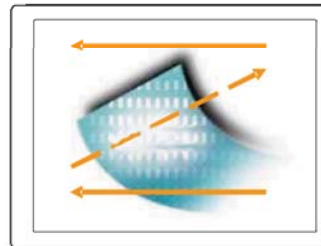

Fig. 2 Reverse scan (Pin19, RSV = High)

6.3 TFT-LCD Interface Signal Description

| Input Signal Interface | | |
|------------------------|----------|---|
| Pin No. | Symbol | Description |
| 1 | VDD | Power Supply, 3.3V (typical) |
| 2 | VDD | Power Supply, 3.3V (typical) |
| 3 | GND | Ground |
| 4 | DPS | Reverse Scan Function [H: Enable; L/NC: Disable] |
| 5 | RxIN0- | LVDS receiver signal channel 0 |
| 6 | RxIN0+ | LVDS Differential Data Input (R0, R1, R2, R3, R4, R5, G0) |
| 7 | GND | Ground |
| 8 | RxIN1- | LVDS receiver signal channel 1 |
| 9 | RxIN1+ | LVDS Differential Data Input (G1, G2, G3, G4, G5, B0, B1) |
| 10 | GND | Ground |
| 11 | RxIN2- | LVDS receiver signal channel 2 |
| 12 | RxIN2+ | LVDS Differential Data Input (B2, B3, B4, B5, DE) |
| 13 | GND | Ground |
| 14 | RxCLKIN- | LVDS receiver signal clock |
| 15 | RxCLKIN+ | |
| 16 | GND | Ground |
| 17 | RxIN3- | LVDS receiver signal channel 3, NC for 6 bit LVDS Input |
| 18 | RxIN3+ | LVDS Differential Data Input (R6, R7, G6, G7, B6, B7, RSV) |
| 19 | RSV | Reserved for Orient Display internal test. Please treat it as NC. |
| 20 | SEL68 | 6/8bits LVDS data input selection [H: 8bits L/NC: 6bit] |

Note 1: Input Signals shall be in low status when VDD is off.

Note 2: High stands for "3.3V", Low stands for "0V", NC stands for "No Connection".

Note 3: RSV stands for "Reserved".

6.4 The Input Data Format

6.4.1 SEL68

SEL68 = “Low” or “NC” for 6 bits LVDS Input



SEL68 = “High” for 8 bits LVDS Input

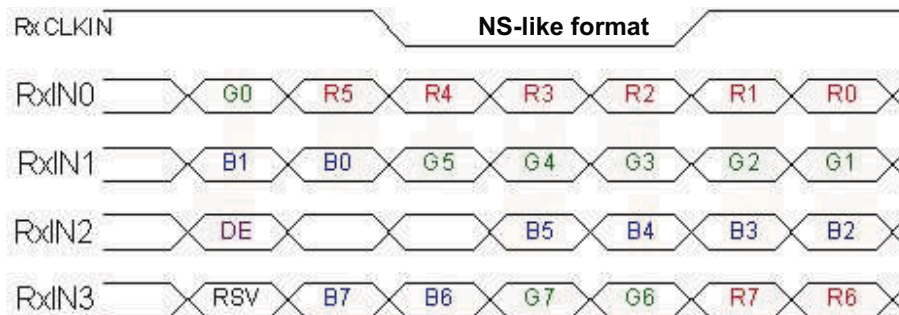

Note1: Please follow PSWG.

Note2: R/G/B data 7:MSB, R/G/B data 0:LSB

| Signal Name | Description | Remark |
|-------------|--------------------|---|
| R7 | Red Data 7 | Red-pixel Data |
| R6 | Red Data 6 | |
| R5 | Red Data 5 | For 8Bits LVDS input |
| R4 | Red Data 4 | MSB: R7 ; LSB: R0 |
| R3 | Red Data 3 | |
| R2 | Red Data 2 | For 6Bits LVDS input |
| R1 | Red Data 1 | MSB: R5 ; LSB: R0 |
| R0 | Red Data 0 | |
| G7 | Green Data 7 | Green-pixel Data |
| G6 | Green Data 6 | |
| G5 | Green Data 5 | For 8Bits LVDS input |
| G4 | Green Data 4 | MSB: G7 ; LSB: G0 |
| G3 | Green Data 3 | |
| G2 | Green Data 2 | For 6Bits LVDS input |
| G1 | Green Data 1 | MSB: G5 ; LSB: G0 |
| G0 | Green Data 0 | |
| B7 | Blue Data 7 | Blue-pixel Data |
| B6 | Blue Data 6 | |
| B5 | Blue Data 5 | For 8Bits LVDS input |
| B4 | Blue Data 4 | MSB: B7 ; LSB: B0 |
| B3 | Blue Data 3 | |
| B2 | Blue Data 2 | For 6Bits LVDS input |
| B1 | Blue Data 1 | MSB: B5 ; LSB: B0 |
| B0 | Blue Data 0 | |
| RxCLKIN | LVDS Data Clock | |
| DE | Data Enable Signal | When the signal is high, the pixel data shall be valid to be displayed. |

Note: Output signals from any system shall be low or Hi-Z state when VDD is off.

6.5 TFT-LCD Interface Timing

6.5.1 Timing Characteristics

| Signal | Symbol | Min. | Typ. | Max. | Unit | |
|--------------------|----------------------|----------|------|------|------|--------------------|
| Clock Frequency | $1/T_{\text{Clock}}$ | 30 | 40 | 50 | MHz | |
| Vertical Section | Period | T_V | 608 | 628 | 1024 | T_{Line} |
| | Active | T_{VD} | -- | 600 | -- | |
| | Blanking | T_{VB} | 8 | 28 | 424 | |
| Horizontal Section | Period | T_H | 960 | 1056 | 1060 | T_{Clock} |
| | Active | T_{HD} | -- | 800 | -- | |
| | Blanking | T_{HB} | 160 | 256 | 260 | |

Note 1: Frame rate is 60 Hz.

Note 2: DE mode.

6.5.2 Input Timing Diagram

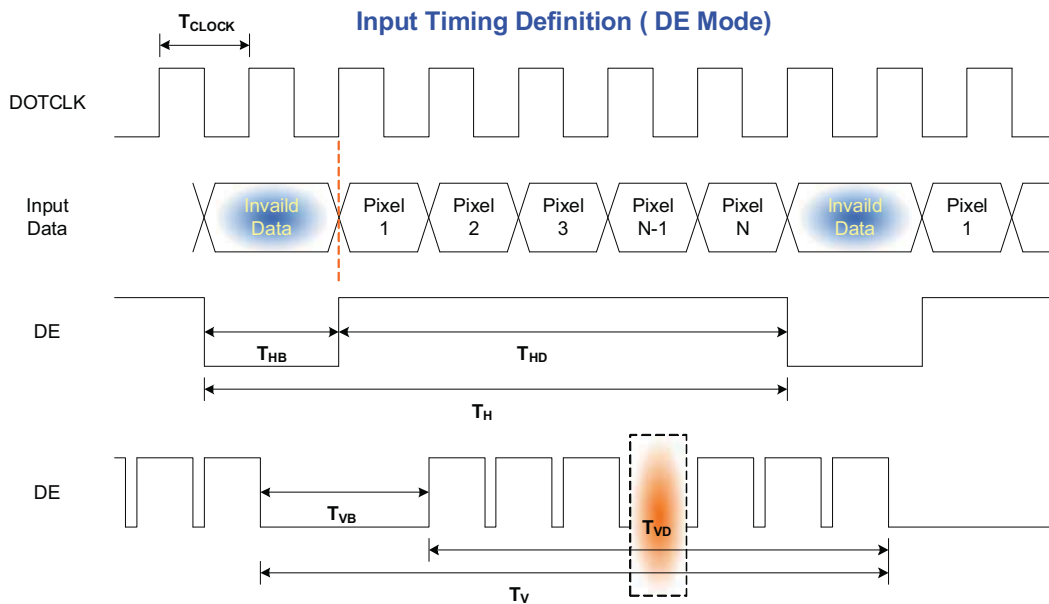

6.6 Power ON/OFF Sequence

VDD power and lamp on/off sequence is as below. Interface signals are also shown in the chart. Signals from any system shall be Hi-Z state or low level when VDD is off.

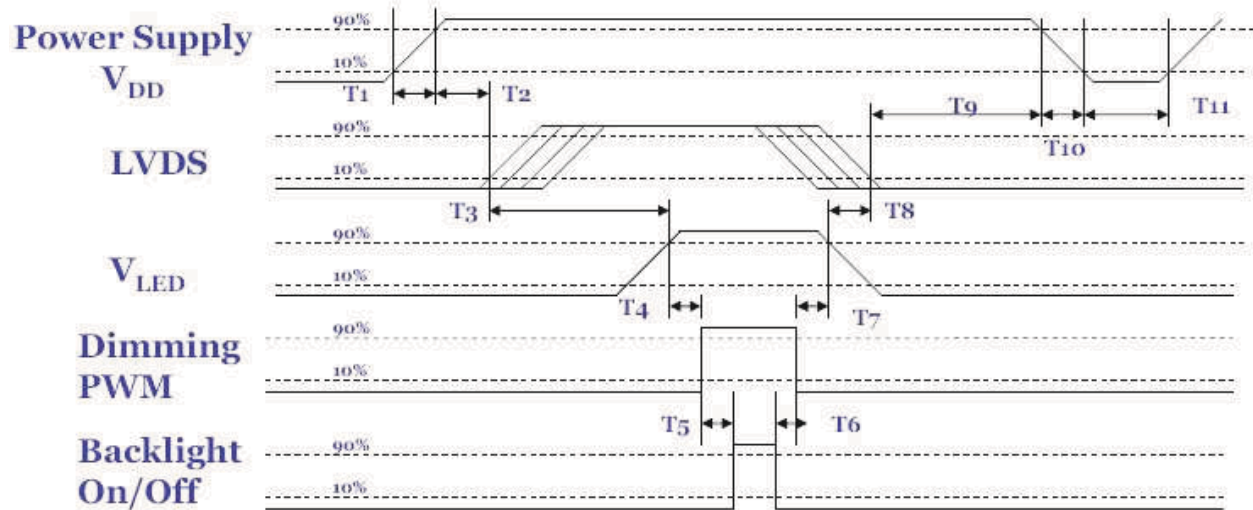

Power ON/OFF sequence timing

| Parameter | Value | | | Units |
|-----------|-------|------|------|-------|
| | Min. | Typ. | Max. | |
| T1 | 0.5 | - | 10 | [ms] |
| T2 | 30 | 40 | 50 | [ms] |
| T3 | 200 | - | - | [ms] |
| T4 | 10 | - | - | [ms] |
| T5 | 10 | - | - | [ms] |
| T6 | 0 | - | - | [ms] |
| T7 | 10 | - | - | [ms] |
| T8 | 100 | - | - | [ms] |
| T9 | 0 | 16 | 50 | [ms] |
| T10 | - | - | 10 | [ms] |
| T11 | 1000 | - | - | [ms] |

The above on/off sequence should be applied to avoid abnormal function in the display. Please make sure to turn off the power when you plug the cable into the input connector or pull the cable out of the connector.

7. Connector & Pin Assignment

Physical interface is described as for the connector on module. These connectors are capable of accommodating the following signals and will be following components.

7.1 TFT-LCD Signal (CN1): LVDS Connector

| Connector Name / Designation | Signal Connector |
|------------------------------|-----------------------------|
| Manufacturer | STM or compatible |
| Connector Model Number | MSB24013P20HA or compatible |
| Adaptable Plug | P24013P20 or compatible |

| Pin No. | Symbol | Pin No. | Symbol |
|---------|---------|---------|---------|
| 1 | VDD | 2 | VDD |
| 3 | GND | 4 | DPS |
| 5 | RxIN0- | 6 | RxIN0+ |
| 7 | GND | 8 | RxIN1- |
| 9 | RxIN1+ | 10 | GND |
| 11 | RxIN2- | 12 | RxIN2+ |
| 13 | GND | 14 | RxCKIN- |
| 15 | RxCKIN+ | 16 | GND |
| 17 | RxIN3- | 18 | RxIN3+ |
| 19 | RSV | 20 | SEL68 |

7.2 LED Backlight Unit (CN2): Driver Connector

| Connector Name / Designation | Lamp Connector |
|------------------------------|------------------------------|
| Manufacturer | ENTERY or compatible |
| Connector Model Number | 3808K-F05N-02R or compatible |
| Mating Model Number | H208K-P05N-02B or compatible |

| Pin No. | symbol | description |
|---------|---------|--------------|
| Pin1 | VCC | 12V input |
| Pin2 | GND | GND |
| Pin3 | On/OFF | 5V-ON,0V-OFF |
| Pin4 | Dimming | PWM |
| Pin5 | NA | |

8. Reliability Test Criteria

| Items | Required Condition | Note |
|--------------------------------|--|--------|
| Temperature Humidity Bias | 40°C, 90%RH, 300 hours | |
| High Temperature Operation | 85°C, 300 hours | |
| Low Temperature Operation | -30°C, 300 hours | |
| Hot Storage | 85°C, 300 hours | |
| Cold Storage | -30°C, 300 hours | |
| Thermal Shock Test | -20°C/ 30 min, 60°C/ 30 min, 100cycles, 40°C minimum ramp rate | |
| Hot Start Test | 85°C/ 1Hr min. power on/off per 5 minutes, 5 times | |
| Cold Start Test | -30°C/ 1Hr min. power on/off per 5 minutes, 5 times | |
| Shock Test (Non-Operating) | 50G, 20ms, Half-sine wave, (±X, ±Y, ±Z) | |
| Vibration Test (Non-Operating) | 1.5G, (10~200Hz, Sine wave) 30 mins/axis, 3 direction (X, Y, Z) | |
| On/off test | On/10 sec, Off/10 sec, 30,000 cycles | |
| ESD | Contact Discharge: ± 8KV, 150pF(330Ω) 1sec, 8 points, 25 times/ point Air Discharge: ± 15KV, 150pF(330Ω) 1sec, 8 points, 25 times/ point | Note 1 |
| EMI | 30-230 MHz, limit 40 dBu V/m, 230-1000 MHz, limit 47 dBu V/m | |

Note1: According to EN61000-4-2, ESD class B: Some performance degradation allowed. No data lost
Self-recoverable. No hardware failures.

Note2:

- Water condensation is not allowed for each test items.
- Each test is done by new TFT-LCD module. Don't use the same TFT-LCD module repeatedly for reliability test.
- The reliability test is performed only to examine the TFT-LCD module capability.
- To inspect TFT-LCD module after reliability test, please store it at room temperature and room humidity for 24 hours at least in advance.

9. Mechanical Characteristics

9.1 LCM Outline Dimension (Front View)

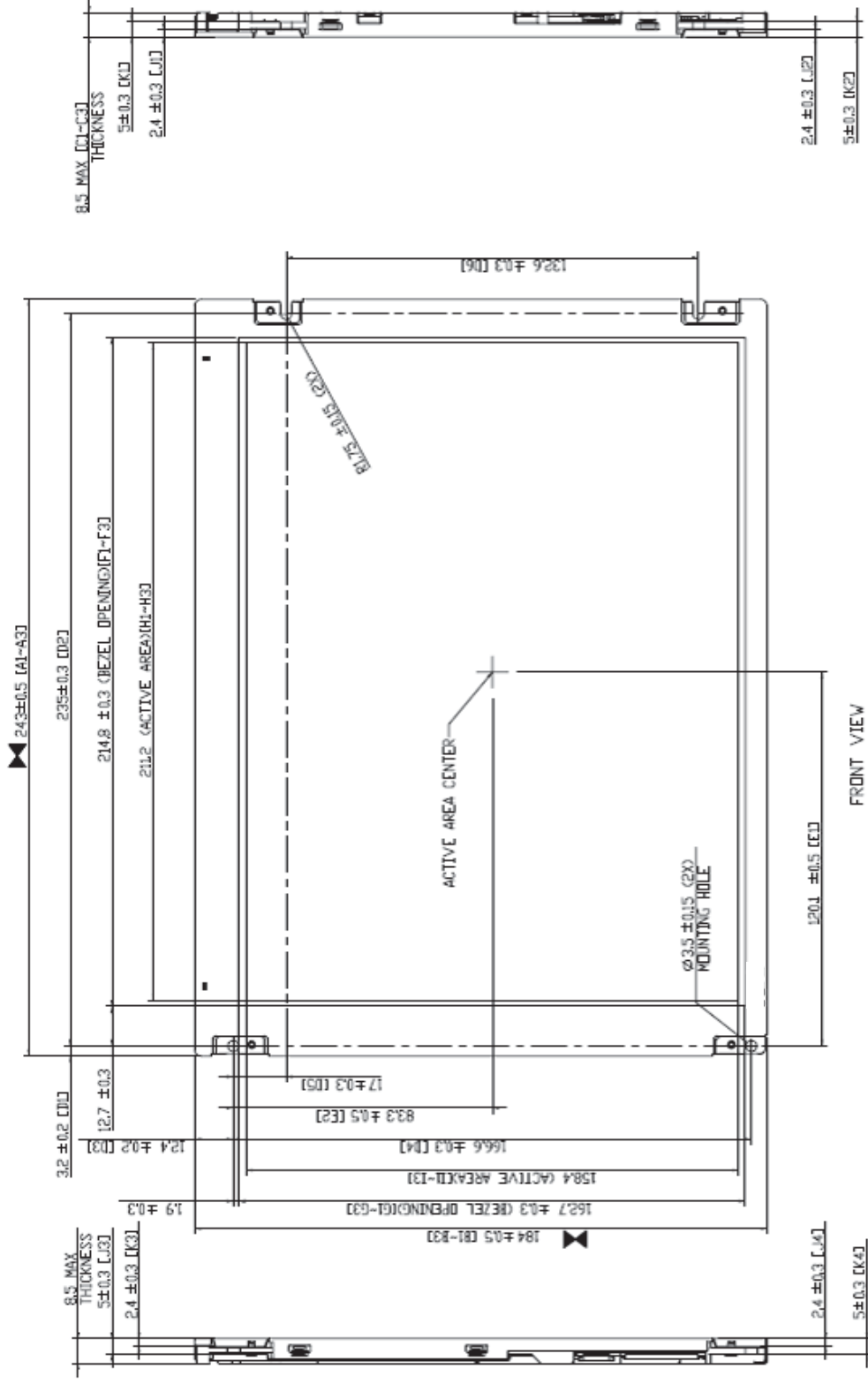

9.2 LCM Outline Dimension (Rear View)

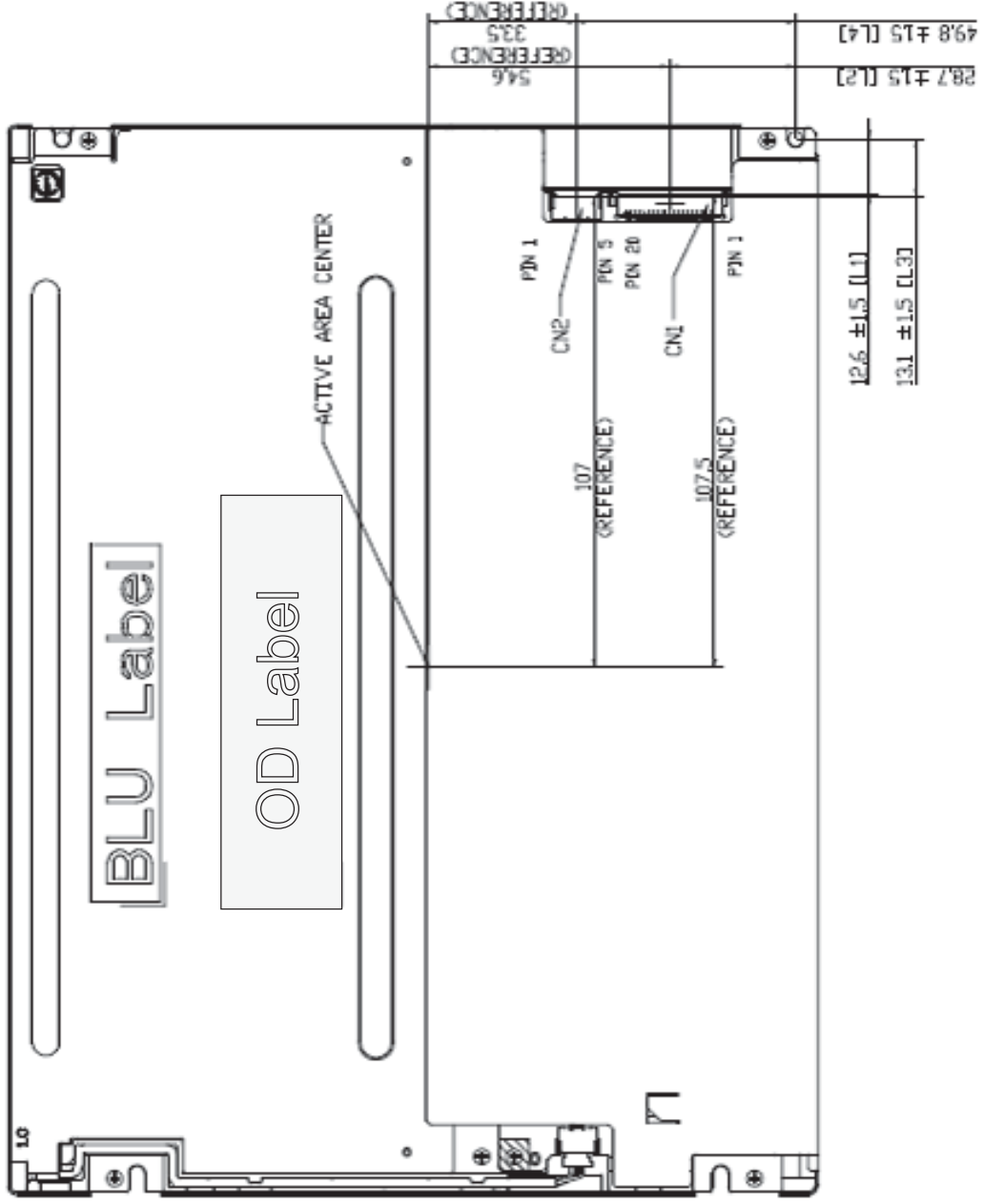

10. Label and Packaging

10.1 Shipping Label (on the rear side of TFT-LCD display)

10.2 Carton Package

11 Safety

11.1 Sharp Edge Requirements

There will be no sharp edges or corners on the display assembly that could cause injury.

11.2 Materials

11.2.1 Toxicity

There will be no carcinogenic materials used anywhere in the display module. If toxic materials are used, they will be reviewed and approved by the responsible Orient Display toxicologist.

11.2.2 Flammability

All components including electrical components that do not meet the flammability grade UL94-V1 in the module will complete the flammability rating exception approval process.

The printed circuit board will be made from material rated 94-V1 or better. The actual UL flammability rating will be printed on the printed circuit board.

11.3 Capacitors

If any polarized capacitors are used in the display assembly, provisions will be made to keep them from being inserted backwards.

11.4 National Test Lab Requirement

The display module will satisfy all requirements for compliance to:

UL 60950

U.S.A. Information Technology Equipment