



**SPECIFICATION  
FOR  
LCD MODULE**

**MODULE NO: AFU800600G-8.4-SN05V9  
REVISION NO: 00**

Customer's Approval:

--

	SIGNATURE	DATE
PREPARED BY (RD ENGINEER)	Alan C.	2011-12-10
CHECKED BY	Leader F.	2011-12-10
APPROVED BY	Leader F.	2011-12-10

## Contents

1. Operating Precautions.....	3
2. General Description .....	4
2.1 Display Characteristics .....	4
2.2 Optical Characteristics .....	5
3. Functional Block Diagram .....	8
4. Absolute Maximum Ratings .....	9
4.1 Absolute Ratings of TFT LCD Module.....	9
4.2 Absolute Ratings of Environment .....	9
5. Electrical Characteristics .....	10
5.1 TFT LCD Module.....	10
5.2 Backlight Unit .....	12
6. Signal Characteristic .....	13
6.1 Pixel Format Image .....	13
6.2 Signal Description .....	14
6.3 Scanning Direction .....	15
6.4 The Input Data Format .....	16
6.5 Interface Timing.....	17
6.6 Power ON/OFF Sequence .....	18
7. Connector & Pin Assignment .....	19
7.1 TFT LCD Signal (CN1): LVDS Connector .....	19
7.2 LED Backlight Unit (CN2): LED Driver Connector .....	19
7.3 LED Light Bar Input Connector (CN3):.....	20
8. Reliability Test Criteria .....	20
9. Mechanical Characteristics.....	21
9.1 LCM Front View.....	21
9.2 LCM Rear View .....	22
10. Label and Packaging.....	23
10.1 Shipping Label (on the rear side of TFT-LCD display) .....	23
10.2 Carton Package .....	23
11 Safety.....	24
11.1 Sharp Edge Requirements .....	24
11.2 Materials.....	24
11.3 Capacitors .....	24

## 1. Operating Precautions

- 1) Since front polarizer is easily damaged, please be cautious not to scratch it.
- 2) Be sure to turn off power supply when inserting or disconnecting from input connector.
- 3) Wipe off water drop immediately. Long contact with water may cause discoloration or spots.
- 4) When the panel surface is soiled, wipe it with absorbent cotton or soft cloth.
- 5) Since the panel is made of glass, it may be broken or cracked if dropped or bumped on hard surface.
- 6) To avoid ESD (Electro Static Discharge) damage, be sure to ground yourself before handling TFT-LCD Module.
- 7) Do not open nor modify the module assembly.
- 8) Do not press the reflector sheet at the back of the module to any direction.
- 9) In case if a module has to be put back into the packing container slot after it was taken out from the container, do not press the center of the LED Reflector edge. Instead, press at the far ends of the LED Reflector edge softly. Otherwise the TFT Module may be damaged.
- 10) At the insertion or removal of the Signal Interface Connector, be sure not to rotate nor tilt the Interface Connector of the TFT Module.
- 11) After installation of the TFT Module into an enclosure (Notebook PC Bezel, for example), do not twist nor bend the TFT Module even momentarily. At designing the enclosure, it should be taken into consideration that no bending/twisting forces are applied to the TFT Module from outside. Otherwise the TFT Module may be damaged.
- 12) Small amount of materials having no flammability grade is used in the LCD module. The LCD module should be supplied by power complied with requirements of Limited Power Source (IEC60950 or UL1950), or be applied exemption.
- 13) Severe temperature condition may result in different luminance, response time.
- 14) Continuous operating TFT-LCD Module under high temperature environment may accelerate LED light bar exhaustion and reduce luminance dramatically.
- 15) The data on this specification sheet is applicable when LCD module is placed in landscape position.
- 16) Continuous displaying fixed pattern may induce image sticking. It is recommended to use screen saver or shuffle content periodically if fixed pattern is displayed on the screen.

## 2. General Description

This specification applies to the 8.4 inch color TFT LCD module AFU800600G-8.4-SN05V9.

AFU800600G-8.4-SN05V9 designed with wide viewing angle; wide operating temperature and long life LEDs backlight is well suited to be the display units for Industrial Applications.

LED driving board for backlight unit is included in this panel and the structure of the LED units is replaceable.

AFU800600G-8.4-SN05V9 is built in timing controller and LVDS interface.

The screen format is intended to support the SVGA (800(H) x 600(V)) screen and 16.2M (RGB 8-bits) or 262k colors (RGB 6-bits).

AFU800600G-8.4-SN05V9 is a RoHS product.

### 2.1 Display Characteristics

The following items are characteristics summary on the table under 25 °C condition:

Items	Unit	Specifications
Screen Diagonal	[inch]	8.4 ( 213.4mm )
Active Area	[mm]	170.4(H) x 127.8(V)
Pixels H x V		800x3(RGB) x 600
Pixel Pitch	[mm]	0.213x 0.213
Pixel Arrangement		R.G.B. Vertical Stripe
Display Mode		TN, Normally White
Nominal Input Voltage VDD	[Volt]	TBD
Typical Power Consumption	[Watt]	TBD
Weight	[Grams]	TBD
Physical Size	[mm]	203.0(W) x 142.5(H) x 8.0(D) (typ.)
Electrical Interface		1 channel LVDS
Surface Treatment		Anti-glare, Hardness 3H
Support Color		262K(6-bit) / 16.2M(8-bit)
Temperature Range Operating Storage (Non-Operating)	[°C] [°C]	-30 to +85 (panel surface temperature) -30 to +85
RoHS Compliance		RoHS Compliance

## 2.2 Optical Characteristics

The optical characteristics are measured under stable conditions at 250C (Room Temperature):

Item	Unit	Conditions	Min.	Typ.	Max.	Note
White Luminance	[cd/m <sup>2</sup> ]	I <sub>F</sub> = 80mA (center point)	TBD	450	-	1
Uniformity	%	9 Points	TBD	75	-	1, 2, 3
Contrast Ratio			TBD	600	-	4
Response Time	[msec]	Rising	-	TBD	TBD	5
	[msec]	Falling	-	TBD	TBD	
	[msec]	Raising + Falling	-	30	TBD	
Viewing Angle	[degree] [degree]	Horizontal (Right) CR ≥ 10 (Left)	TBD	80 80	- -	6
	[degree] [degree]	Vertical (Upper) CR ≥ 10 (Lower)	TBD	80 60	- -	
Color / Chromaticity Coordinates (CIE 1931)		Red x	TBD	TBD	TBD	1
		Red y	TBD	TBD	TBD	
		Green x	TBD	TBD	TBD	
		Green y	TBD	TBD	TBD	
		Blue x	TBD	TBD	TBD	
		Blue y	TBD	TBD	TBD	
		White x	0.26	0.31	0.36	
		White y	0.28	0.33	0.38	
Color Gamut	%			45	-	1

Note 1: Measurement method

Equipment : Pattern Generator, Power Supply, Digital Voltmeter, Luminance meter (SR\_3 or equivalent)

Aperture 1 ° with 50cm viewing distance

Test Point Center

Environment < 1 lux

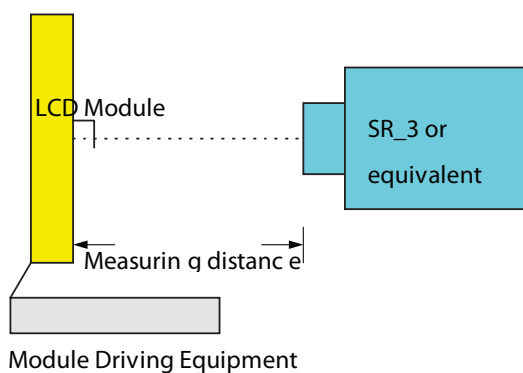

Note 2: Definition of 9 points position (Display active area : 170.4(H) x 127.8(V))

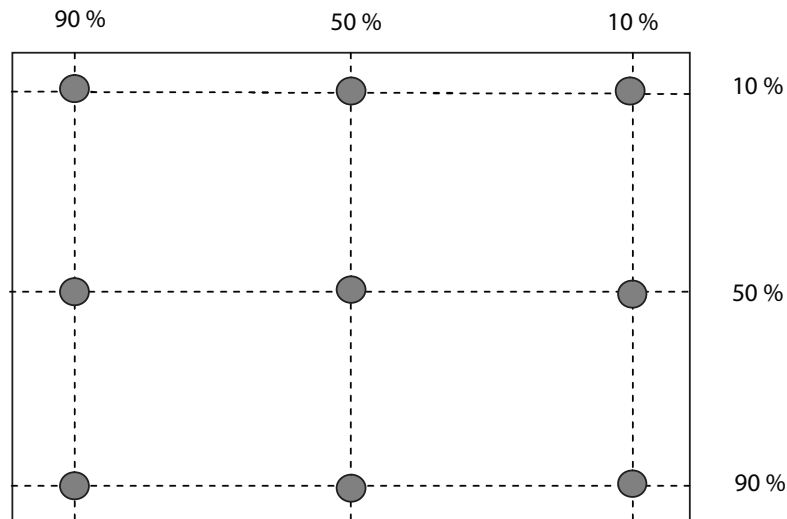

Note 3: The luminance uniformity of 9 points is defined by dividing the minimum luminance value by the maximum test point luminance

$$\delta_{w9} = \frac{\text{Minimum Brightness of nine points}}{\text{Maximum Brightness of nine points}}$$

Note 4 : Definition of contrast ratio (CR):

$$\text{Contrast ratio (CR)} = \frac{\text{Brightness on the "White" state}}{\text{Brightness on the "Black" state}}$$

Note 5: Definition of response time:

The output signals of photo detector are measured when the input signals are changed from "White" to "Black" (falling time) and from "Black" to "White" (rising time), respectively. The response time interval is between 10% and 90% of amplitudes. Please refer to the figure as below.

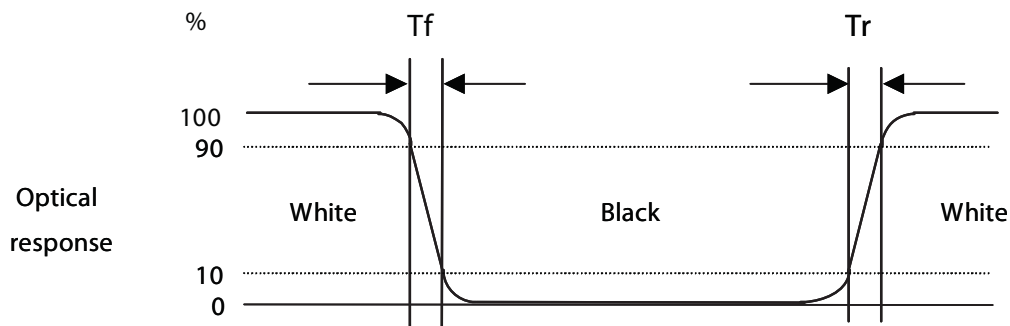

Note 6: Definition of viewing angle

Viewing angle is the measurement of contrast ratio  $C_{\theta}$  at the screen center, over a  $180^\circ$  horizontal and  $180^\circ$  vertical range (off-normal viewing angles). The  $180^\circ$  viewing angle range is broken down as below:  $90^\circ$  ( $\theta$ ) horizontal left and right, and  $90^\circ$  ( $\phi$ ) vertical high (up) and low (down). The measurement direction is typically perpendicular to the display surface with the screen rotated to its center to develop the desired measurement viewing angle.

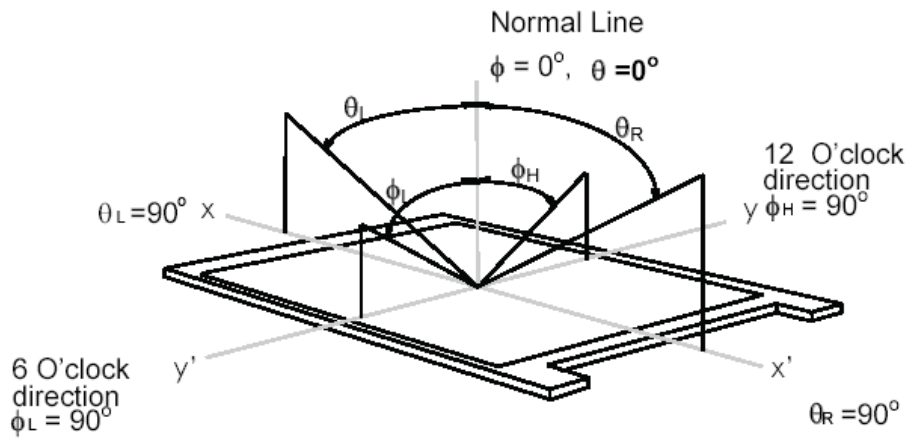

### 3. Functional Block Diagram

The following diagram shows the functional block of the 8.4 inch color TFT/LCD module:

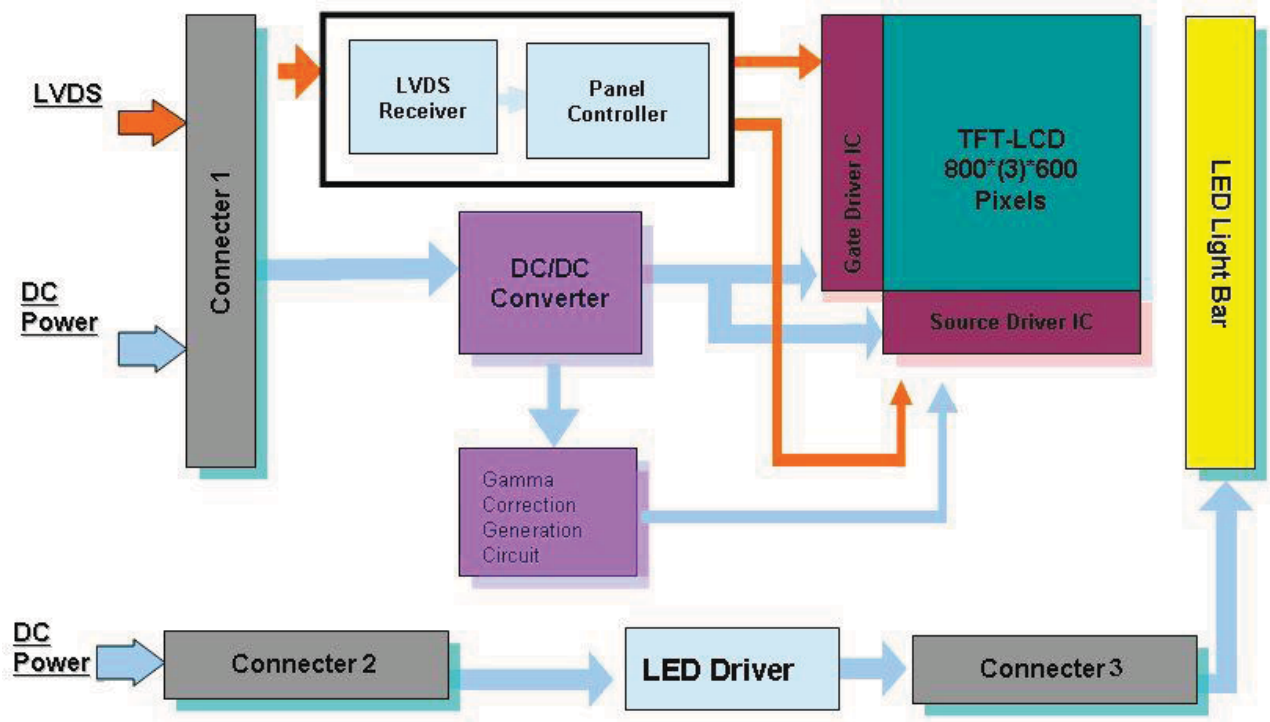



## 4. Absolute Maximum Ratings

### 4.1 Absolute Ratings of TFT LCD Module

Item	Symbol	Min	Max	Unit	Conditions
Logic/LCD Drive	VDD	-0.3	+3.6	[Volt]	

### 4.2 Absolute Ratings of Environment

Item	Symbol	Min	Max	Unit
Operating Temperature	TOP	-30	+85	[ °C]
Operation Humidity	HOP	5	90	[%RH]
Storage Temperature	TST	-30	+85	[ °C]
Storage Humidity	HST	5	90	[%RH]

Note: Maximum Wet-Bulb should be 39°C and no condensation.

## 5. Electrical Characteristics

### 5.1 TFT LCD Module

#### 5.1.1 Power Specification

Symbol	Parameter	Min	Typ	Max	Units	Remark
V <sub>DD</sub>	Logic/LCD Drive Voltage	TBD	3.3	TBD	[Volt]	± 10%
I <sub>VDD</sub>	VDD Current	-	TBD	TBD	[mA]	64 Gray Bar Pattern (VDD=3.3V, at 60Hz)
I <sub>rush LCD</sub>	LCD Inrush Current	-	-	TBD	[A]	Note 1
P <sub>VDD</sub>	VDD Power	-	TBD	TBD	[Watt]	64 Gray Bar Pattern (VDD=3.3V, at 60Hz)

Note 1: Measurement condition:

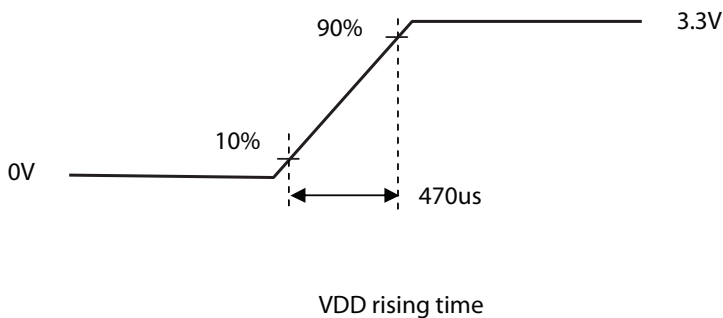
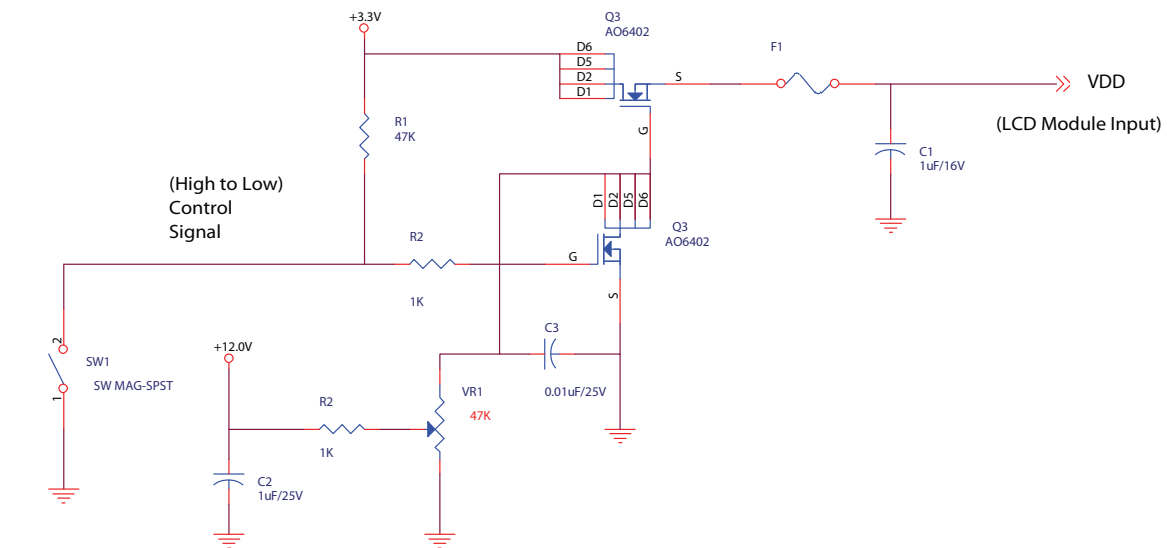

64 Gray pattern

### 5.1.2 Signal Electrical Characteristics

Input signals shall be low or Hi-Z state when VDD is off.

Symbol	Item	Min.	Typ.	Max.	Unit	Remark
VTH	Differential Input High Threshold	-	-	100	[mV]	VICM=1.2V
VTL	Differential Input Low Threshold	-100	-	-	[mV]	VICM=1.2V
VID	Input Differential Voltage	100	400	600	[mV]	
VICM	Differential Input Common Mode Voltage	1.1		1.6	[V]	VTH/VTL= ±100mV

Note: LVDS Signal Waveform.

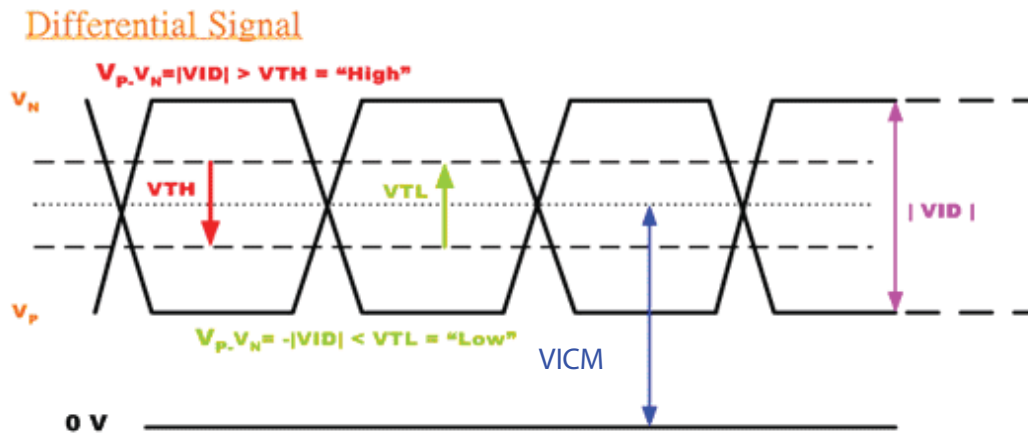

## 5.2 Backlight Unit

### 5.2.1 Parameter guideline for LED backlight

Following characteristics are measured under a stable condition using an inverter at 250C (Room Temperature):

Symbol	Parameter	Min.	Typ.	Max.	Unit	Remark
V <sub>CC</sub>	Input Voltage	TBD	TBD	TBD	[Volt]	
I <sub>VCC</sub>	Input Current	TBD	TBD	TBD	[A]	100% PWM Duty
P <sub>VCC</sub>	Power Consumption	TBD	TBD	TBD	[Watt]	100% PWM Duty
I <sub>rush LED</sub>	Inrush Current	TBD	TBD	TBD	[A]	at rising time=470us
F <sub>PWM</sub>	Dimming Frequency	TBD	TBD	TBD	[Hz]	
	Swing Voltage	TBD	TBD	TBD	V	
	Dimming Duty Cycle	TBD	TBD	TBD	%	
I <sub>F</sub>	LED Forward Current	TBD	TBD	TBD	mA	Ta = 25 °C
V <sub>F</sub>	LED Forward Voltage	TBD	TBD	TBD	Volt	I <sub>F</sub> = 80mA, Ta = -30°C
		TBD	TBD	TBD	Volt	I <sub>F</sub> = 80mA, Ta = 25°C
		TBD	TBD	TBD		I <sub>F</sub> = 80mA, Ta = 85°C
P <sub>LED</sub>	LED Power Consumption	TBD	TBD	TBD	Watt	I <sub>F</sub> = 80mA, Ta = 25°C
Operation Lifetime		50,000			Hrs	I <sub>F</sub> =80mA, Ta= 25 °C

Note 1: Ta means ambient temperature of TFT-LCD module.

Note 2: V<sub>CC</sub>, I<sub>VCC</sub>, P<sub>VCC</sub>, I<sub>rush LED</sub> are defined for LED B/L.(100% duty of PWM dimming)

Note 3: I<sub>F</sub>, V<sub>F</sub>, P<sub>LED</sub> are defined for LED Light Bar. There is two LED channel (AN1-CA1-CA2) in back light unit.

Note 4: If AFU800600G-8.4-SN05V9 module is driven by high current or at high ambient temperature & humidity condition.

The operating life will be reduced.

Note 5: Operating life means brightness goes down to 50% initial brightness. Minimum operating life time is estimated data.



## 6.2 Signal Description

LVDS is a differential signal technology for LCD interface and high speed data transfer device. The connector pin definition is as below.

Pin No.	Symbol	Description
1	VDD	Power Supply, 3.3V (typical)
2	VDD	Power Supply, 3.3V (typical)
3	UD	Vertical Reverse Scan Control, When UD=Low or NC ☒ Normal Mode. When UD=High ☒ Vertical Reverse Scan. <small>Note</small>
4	LR	Horizontal Reverse Scan Control, When LR=Low or NC ☒ Normal Mode. When LR=High ☒ Horizontal Reverse Scan. <small>Note</small>
5	RxIN1-	LVDS differential data input Pair 0
6	RxIN1+	
7	GND	Ground
8	RxIN2-	LVDS differential data input Pair 1
9	RxIN2+	
10	GND	Ground
11	RxIN3-	LVDS differential data input Pair 2
12	RxIN3+	
13	GND	Ground
14	RxCLKIN-	LVDS differential Clock input Pair
15	RxCLKIN+	
16	GND	Ground
17	SEL 68	LVDS 6/8 bit select function control, Low or NC ☒ 6 Bit Input Mode. High ☒ 8 Bit Input Mode. <small>Note</small>
18	NC	NC
19	RxIN4-	LVDS differential data input Pair 3. Must be set to NC in 6 bit input mode.
20	RxIN4+	

Note : "Low" stands for 0V. "High" stands for 3.3V. "NC" stands for "No Connected."

### 6.3 Scanning Direction

The following figures show the image seen from the front view. The arrow indicates the direction of scan.

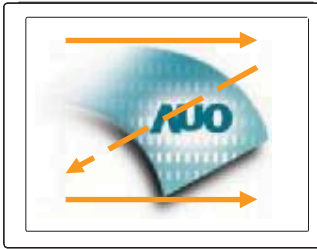

Fig. 1

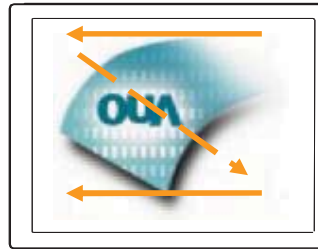

Fig. 2



Fig. 3

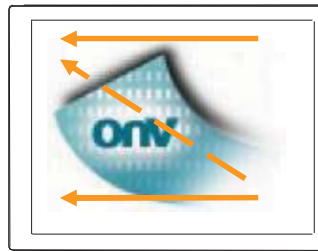

Fig. 4

Fig. 1 Normal scan (Pin3, UD = Low or NC ; Pin4, RL = Low or NC)

Fig. 2 Reverse scan (Pin3, UD = Low or NC ; Pin4, RL = High)

Fig. 3 Reverse scan (Pin3, UD = High ; Pin4, RL = Low or NC)

Fig. 4 Reverse scan (Pin3, UD = High ; Pin4, RL = High)

## 6.4 The Input Data Format

### 6.4.1 SEL68

SEL68 = "Low" or "NC" for 6 bits LVDS Input

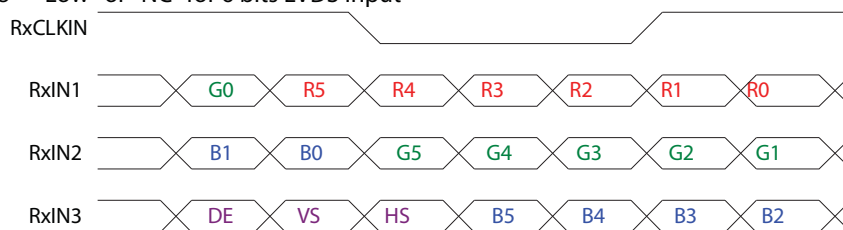

SEL68 = "High" for 8 bits LVDS Input

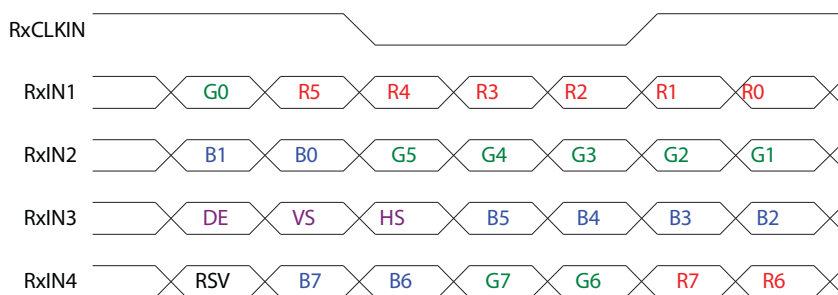

Note1 : Please follow PSWG.

Note2 : R/G/B data 7:MSB, R/G/B data 0:LSB

Signal Name	Description	Remark
R7	Red Data 7 (MSB)	Red-pixel Data Each red pixel's brightness data consists of these 8 bits pixel data.
R6	Red Data 6	
R5	Red Data 5	
R4	Red Data 4	
R3	Red Data 3	
R2	Red Data 2	
R1	Red Data 1	
R0	Red Data 0 (LSB)	
B7	Blue Data 7 (MSB)	Blue-pixel Data Each blue pixel's brightness data consists of these 8 bits pixel data.
B6	Blue Data 6	
B5	Blue Data 5	
B4	Blue Data 4	
B3	Blue Data 3	
B2	Blue Data 2	
B1	Blue Data 1	
B0	Blue Data 0 (LSB)	
G7	Green Data 7 (MSB)	Green-pixel Data Each green pixel's brightness data consists of these 8 bits pixel data.
G6	GreenData 6	
G5	GreenData 5	
G4	GreenData 4	
G3	GreenData 3	
G2	GreenData 2	
G1	GreenData 1	
G0	GreenData 0 (LSB)	
RxCLKIN+ RxCLKIN-	LVDS Clock Input	
DE	Display Enable	
VS	Vertical Sync	
HS	Horizontal Sync	

Note: Output signals from any system shall be low or Hi-Z state when VDD is off.



## 6.5 Interface Timing

### 6.5.1 Timing Characteristics

DE mode only

Parameter		Symbol	Min.	Typ.	Max.	Unit	Condition
Clock frequency		$1/T_{\text{Clock}}$	33.6	39.8	48.3	MHz	
Vertical Section	Period	$T_V$	608	628	650	$T_H$	
	Active	$T_{VD}$	600	600	600		
	Blanking	$T_{VB}$	8	28	50		
Horizontal Section	Period	$T_H$	920	1056	1240	$T_{\text{Clock}}$	
	Active	$T_{HD}$	800	800	800		
	Blanking	$T_{HB}$	120	256	440		

Note: Frame rate is 60 Hz.

Note: DE mode.

### 6.5.2 Input Timing Diagram

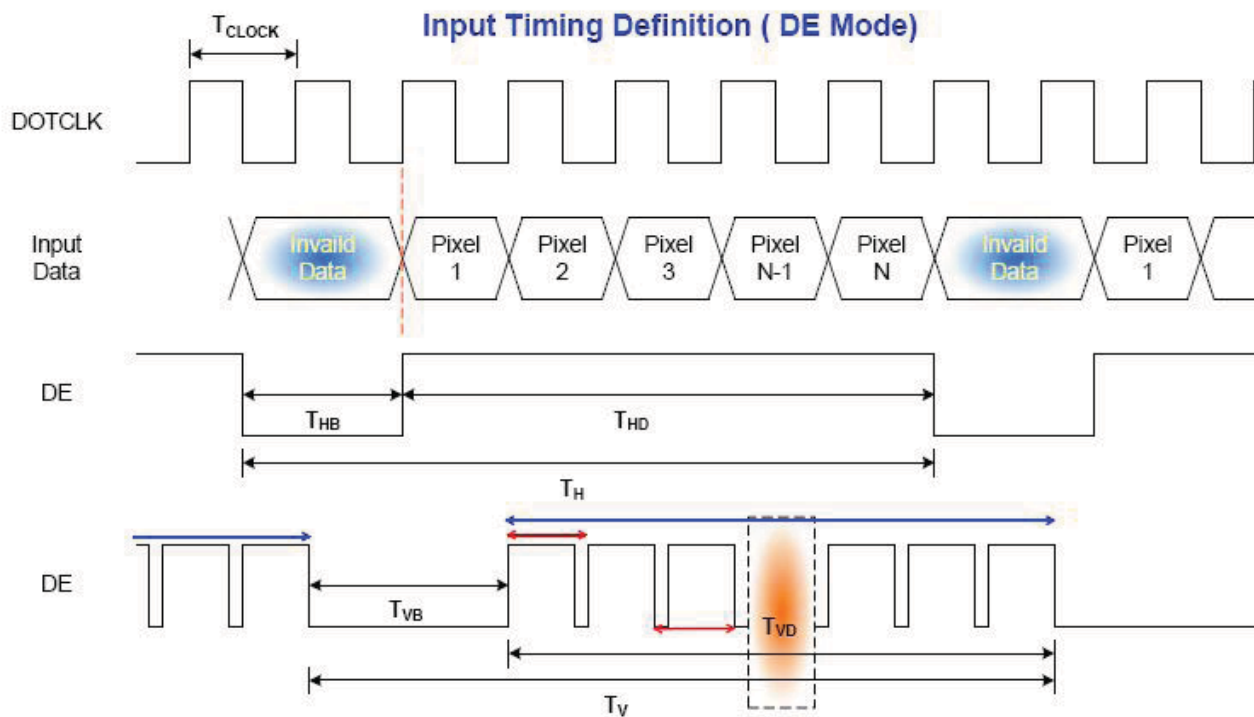

## 6.6 Power ON/OFF Sequence

VDD power and lamp on/off sequence is as below. Interface signals are also shown in the chart. Signals from any system shall be Hi-Z state or low level when VDD is off.

TBD

The above on/off sequence should be applied to avoid abnormal function in the display. Please make sure to turn off the power when you plug the cable into the input connector or pull the cable out of the connector.

## 7. Connector & Pin Assignment

Physical interface is described as for the connector on module. These connectors are capable of accommodating the following signals and will be following components.

### 7.1 TFT LCD Signal (CN1): LVDS Connector

Connector Name / Designation	Signal Connector
Manufacturer	STM, Hirose or compatible
Connector Model Number	STM -MSB24013P20HA, Hirose- DF19LA-20P-1H or compatible
Mating Model Number	STM-P24013P20, Hirose-DF19-20S-1C or compatible

Pin No.	Signal Name	Pin No.	Signal Name
1	VDD	2	VDD
3	UD	4	LR
5	RxIN1-	6	RxIN1+
7	GND	8	RxIN2-
9	RxIN2+	10	GND
11	RxIN3-	12	RxIN3+
13	GND	14	RxCKIN-
15	RxCKIN+	16	GND
17	SEL 68	18	NC
19	RxIN4-	20	RxIN4+

### 7.2 LED Backlight Unit (CN2): LED Driver Connector

Connector Name / Designation	Lamp Connector
Manufacturer	TBD
Connector Model Number	TBD
Mating Model Number	TBD

Pin #	Symbol	Pin Description
1	VCC	12V input
2	GND	GND
3	Display_ON/OFF	+5.0V or +3.3 V:ON, 0V:OFF
4	Dimming	PWM

### 7.3 LED Light Bar Input Connector (CN3):

Manufacturer	TBD
Connector Model Number	TBD
Mating Connector Model Number	TBD

Pin #	Symbol	Pin Description
1	AN1	LED anode
2	CA1	LED cathode
3	CA2	LED cathode

Pin #	Symbol	Cable color
1	AN1	Red
2	CA1	Black
3	CA2	Black

### 8. Reliability Test Criteria

Items	Required Condition	Note
Temperature Humidity Bias	40°C/90%,300 hours	
High Temperature Operation	85°C,300 hours	
Low Temperature Operation	-30°C,300 hours	
Hot Storage	85°C,300 hours	
Cold Storage	-30°C,300 hours	
Thermal Shock Test	-20°C/30 min ,600C/30 min ,100cycles	
Shock Test (Non-Operating)	50G,20ms,Half-sine wave,(±X, ±Y, ±Z)	
Vibration Test (Non-Operating)	1.5G, (10~200Hz, P-P) 30 mins/axis (X, Y, Z)	
On/off test	On/10 sec, Off/10 sec, 30,000 cycles	
ESD	Contact Discharge: ± 8KV, 150pF(330Ω) 1sec, 8 points, 25 times/ point Air Discharge: ± 15KV, 150pF(330Ω) 1sec, 8 points, 25 times/ point	Note 1

Note1: According to EN61000-4-2, ESD class B: Some performance degradation allowed. No data lost

. Self-recoverable. No hardware failures.

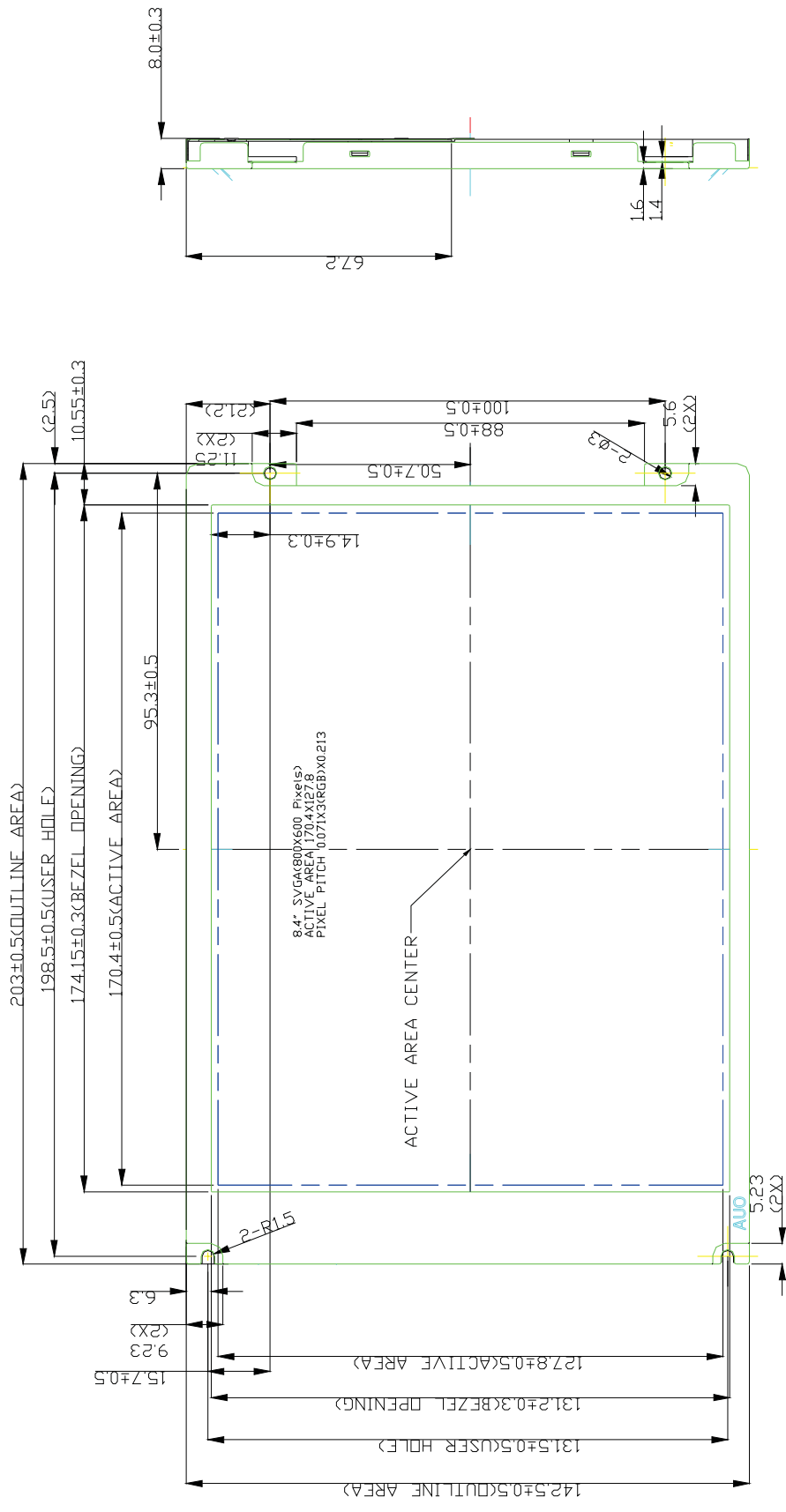

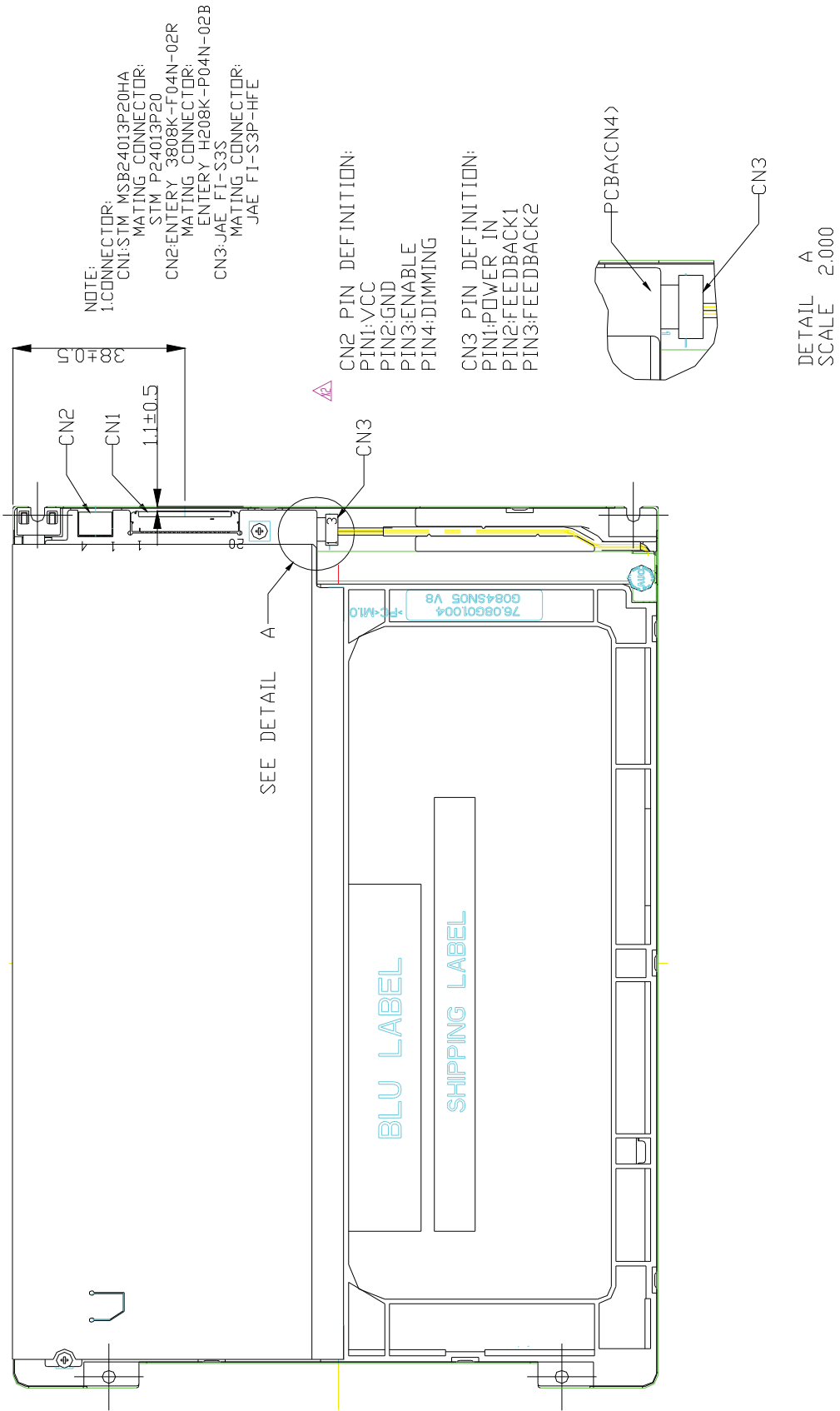

## 10. Label and Packaging

### 10.1 Shipping Label (on the rear side of TFT-LCD display)



### 10.2 Carton Package

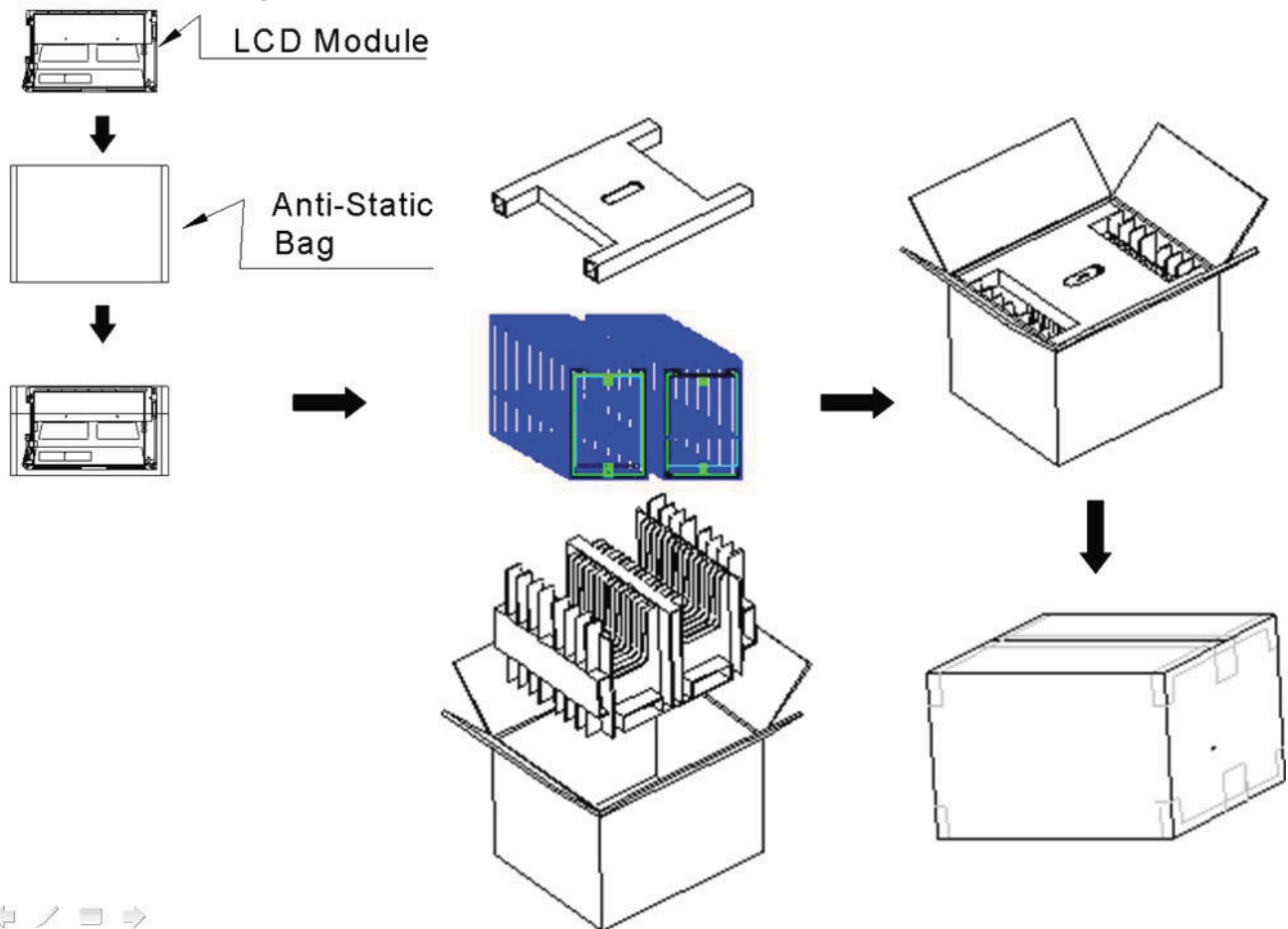

#### Note:

1. Max. Capacity: 30pcs LCD Modules / per carton
2. Max. Weight: 9.5 kg / per carton
3. The outside dimension of carton is 405(L) mm x 328(W) mm x 301(H) mm

## 11 Safety

### 11.1 Sharp Edge Requirements

There will be no sharp edges or corners on the display assembly that could cause injury.

### 11.2 Materials

#### 11.2.1 Toxicity

There will be no carcinogenic materials used anywhere in the display module. If toxic materials are used, they will be reviewed and approved by the responsible OD's toxicologist.

#### 11.2.2 Flammability

All components including electrical components that do not meet the flammability grade UL94-V1 in the module will complete the flammability rating exception approval process.

The printed circuit board will be made from material rated 94-V1 or better. The actual UL flammability rating will be printed on the printed circuit board.

### 11.3 Capacitors

If any polarized capacitors are used in the display assembly, provisions will be made to keep them from being inserted backwards.