

EMI FILTER

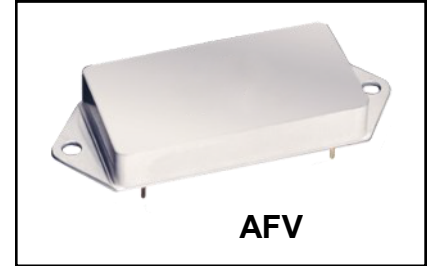

Description

The AFV461 EMI filter will reduce the input line reflected ripple current of all DC-DC converter families to levels below the CEO3 limits of MIL-STD-461. This filter is intended for applications requiring compatibility to MIL-STD-704A.

These EMI filters are manufactured in a facility certified to MIL-PRF-38534 and are available with military screening. Four grades are offered with different screening options. Refer to Part Number section.

Features

- 4.0 A Maximum Input Current
- 40 dB Noise Reduction min. @100 kHz
- -55°C to +125°C Operation
- Class H per MIL-PRF-38534
- Compatible with all standard 28 Volts Input DC-DC Converters
- No Derating for -55°C to +125°C Operation
- No Tantalum Capacitors for High Reliability

Typical Application

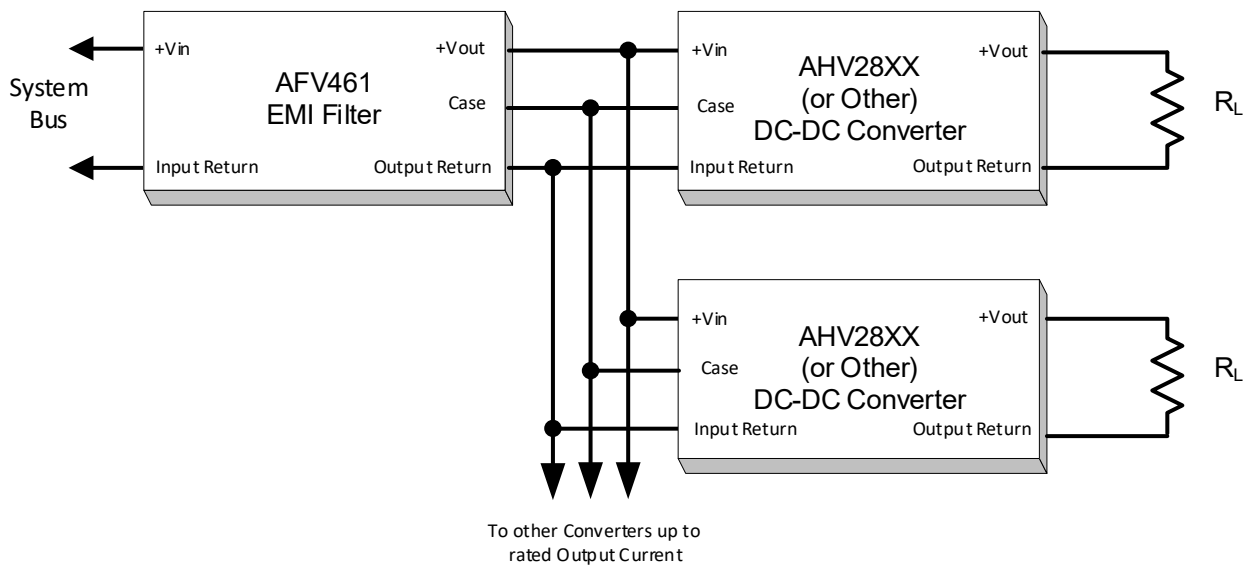

Absolute Maximum Ratings, Note 1

Input Voltage	50 V DC
Input Current	4.0 A
Input Ripple	1.0 A
Power Dissipation	4.0 W
Lead Soldering Temperature	+300°C for 10 seconds
Case Temperature-Operating	-55°C to +125°C
Case Temperature-Storage	-65°C to +150°C

Specifications

Parameter	Conditions	Min.	Typ.	Max.	Unit
Input Voltage	Steady State	0	28	40	V _{DC}
	Transient, 1 second	—	—	80	
Input Current	DC	—	—	4.0	A
	Ripple	—	—	1.0	A RMS
Output Voltage, Note 1	Steady State	$V_{OUT} = V_{IN} - I_{IN} (R_{DC})$			V _{DC}
Output Current	Steady State	—	—	4.0	A
DC Resistance (R _{DC})	Steady State	0.07	0.10	0.15	Ω
Noise Reduction	100 kHz to 50 MHz	40	—	—	dB
Capacitance	Any Pin and Case	—	—	4200	pF
Isolation	Any Pin to Case 500 V DC	100	—	—	MΩ
Device Weight		—	—	39	g

1. Typical Applications result in Vout within 2 % of Vin

AFV461 Block Diagram

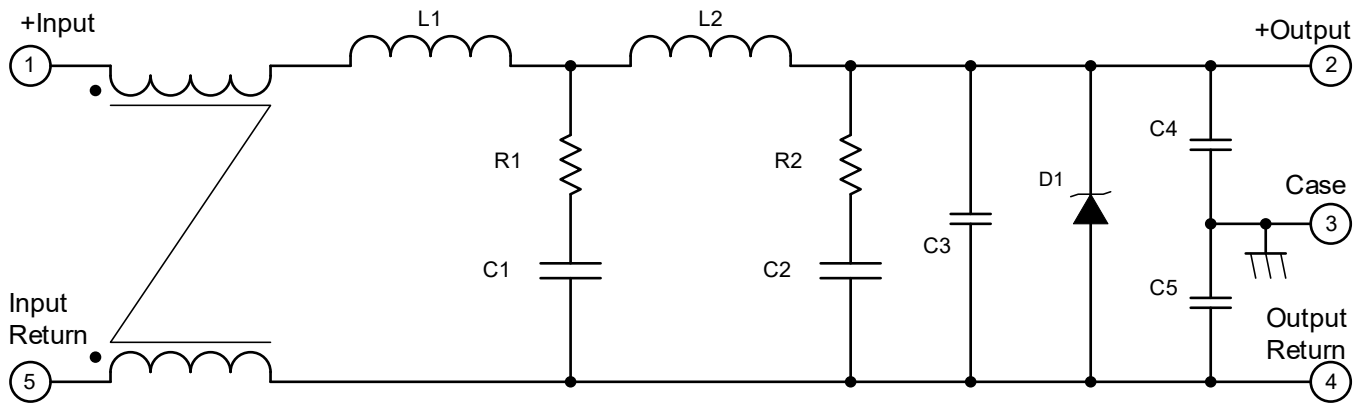

Refer to last page for Pin Designation

Device Synchronization

Whenever multiple DC-DC converters are utilized in a single system, significant low frequency noise may be generated due to slight difference in the switching frequencies of the converters (beat frequency noise). Because of the low frequency nature of this noise (typically less than 10 kHz), it is difficult to filter out and may interfere with proper operation of sensitive systems (communications, radar or telemetry). IR HiRel offers an option, which provides synchronization of multiple AHE/ATW type converters, thus eliminating this type of noise. To take advantage of this capability, the system designer must assign one of the converters as the master. Then, by definition, the remaining converters become slaves and will operate at the masters' switching frequency. The user should be aware that the synchronization system is fail-safe; that is, the slaves will continue operating should the master frequency be interrupted for any reason. The layout must be such that the synchronization output of the master device is connected to the synchronization input of each slave device. It is advisable to keep this run short to minimize the possibility of radiating the 250 kHz switching frequency. A typical connection is illustrated on the cover sheet of this document.

The appropriate converters must be ordered to take advantage of this feature. After selecting the converters required for the system, a 'MSTR' suffix is added for the master converter part number and an 'SLV' suffix is added for slave part number. See Part Number section of the applicable converter data sheets.

AFV461 Case Outlines

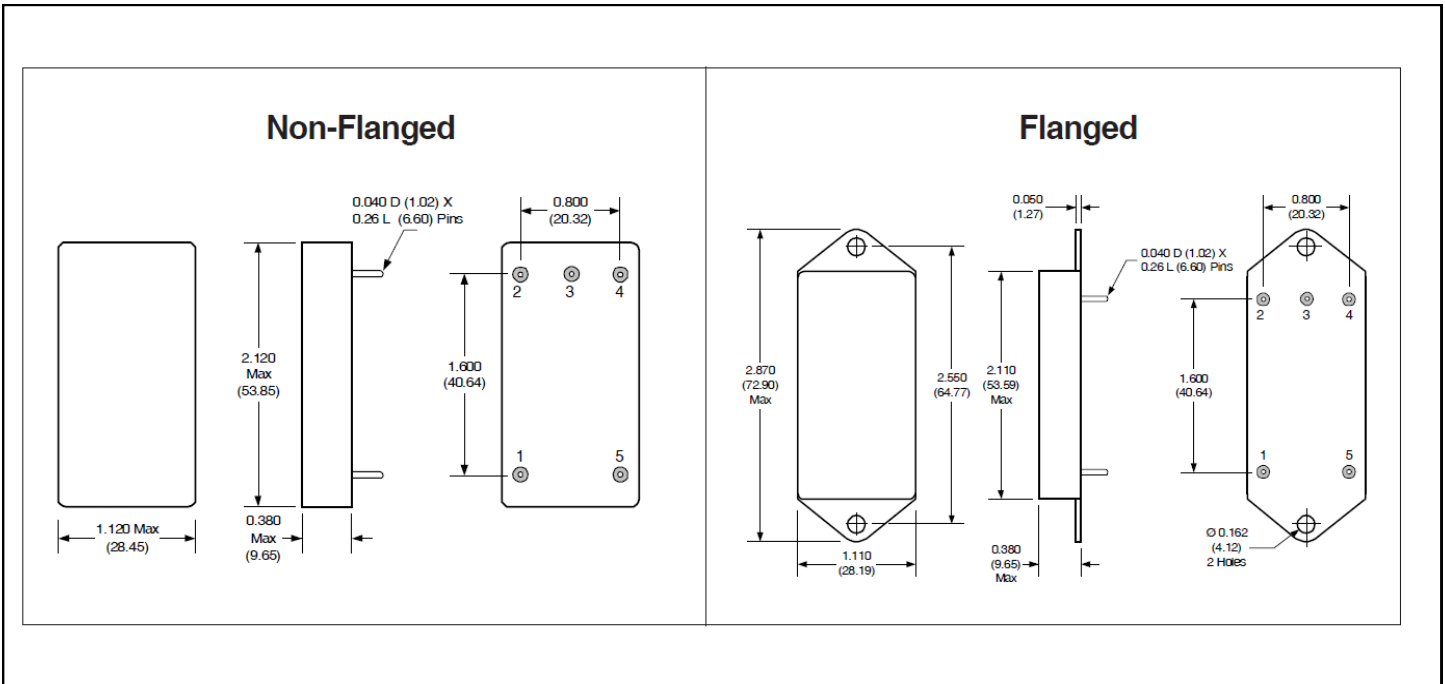

Pin Designation

Pin #	Designation
1	+ Input
2	+ Output
3	Case
4	Output Return
5	Input Return

Available Standard Military Drawing (SMD) Cross Reference

Standard Military Drawing PIN	Vendor CAGE number	Vendor similar PIN
91020-02HXA	52467	AFV461/CH
91020-02HZA	52467	AFV461F/CH

Available Screening Levels and Process Variations for AFV461 Series

Requirement	MIL-STD-883 Method	No Suffix	ES Suffix	HB Suffix	CH Suffix
Temperature Range	—	-20 to +85°C	-55°C to +125°C	-55°C to +125°C	-55°C to +125°C
Element Evaluation	—	—	—	—	MIL-PRF-38534
Internal Visual	2017	*	Yes	Yes	Yes
Temperature Cycle	1010	—	Cond B	Cond C	Cond C
Constant Acceleration	2001	—	500g	Cond A	Cond A
Burn-In	1015	48 hrs @ 125°C	48 hrs @ 125°C	160 hrs @ 125°C	160 hrs @ 125°C
Final Electrical (Group A)	MIL-PRF-38534	25°C	25°C	-55°C, +25°C, +125°C	-55°C, +25°C, +125°C
Seal, Fine and Gross	1014	*	Cond A, C	Cond A, C	Cond A, C
External Visual	2009	*	Yes	Yes	Yes

* Per Commercial Standards

