



## Specification for TFT

### AFY1280800A0-10.1INTH-C

Revision M

A	Orient Display
FY	TFT Type
1280800	Resolution 1280 x 800
A0	Serial A0
10.1	10.1", Module Dimension 232.90 x 154.60 x 6.55 mm
I	IPS Display
N	Top: 00~+50°C; Tstr: -20~+60°C
T	Transmissive
H	Hight Brightness, 900cd/m2
C	Capacitive Touch Panel
/	HX8288-A/HX8695-B OR COMPATIBLE(TFT)
/	LVDS interface



## REVISION RECORD

Rev No.	Rev date	Contents	Remarks
O	2019.12.03	First release	Preliminary
A	2019.12.25	Change TP-FOG.	Detisl as page 6.
B	2020.01.07	Change #27,#37 interface.	Detisl as page 6,9.
C	2020.01.13	Change LENS.	Detisl as page 6.
D	2020.01.25	Change TP-FPC.	Detisl as page 6.
E	2020.02.28	TP-FPC Bending shipment.	Detisl as page 6.
F	2020.04.14	Change GENERAL INFORMATION detail as in page 3th. and BACKLIGHT detail as in page 5th.	Page 3 and page 5
G	2020.04.29	Change ELECTRICAL CHARACTERISTICS detail in page 4 and Change INTERFACE DESCRIPTION detail in page 9 and 10 and Change ABSOLUTE MAXIMUM RATINGS detail in page 3 and Change TOUCH PANEL CHARACTERISTICS in page 5	Page 3 and page 4 and page5 and page 9、 10
H	2020.5.11	Change Ambient Illumination for appearance and functional inspection	P19
I	2020.6.28	Add optical data	P6
J	2020.8.28	Change PIN description	P9
k	2020.11.25	Update TFT DC CHARACTERISTICS; Update INTERFACE DESCRIPTION	P4、 P9
L	2022.04.01	Update ELECTRICAL CHARACTERISTICS	P4
M	2022.07.25	Update Operating Current	P4

## CONTENTS

1. GENERAL INFORMATION .....	3
2. ABSOLUTE MAXIMUM RATINGS.....	3
3. ELECTRICAL CHARACTERISTICS.....	4
4. BACKLIGHT CHARACTERISTICS .....	5
5. TOUCH PANEL CHARACTERISTICS.....	5
6. EXTERNAL DIMENSIONS.....	6
7. ELECTRO-OPTICAL CHARACTERISTICS .....	7
8. INTERFACE DESCRIPTION.....	9
9. AC CHARACTERISTICS .....	11
10. POWER SEQUENCE.....	15
11. RELIABILITY TEST CONDITIONS .....	18
12. INSPECTION CRITERION .....	19
13. HANDLING PRECAUTIONS.....	32
14. PRECAUTION FOR USE.....	33
15. PACKING SPECIFICATION.....	33

# 1. GENERAL INFORMATION

No.	Item	Contents	Unit
1	LCD size	10.1 inch (Diagonal)	/
2	Display mode	IPS/Normally black/Transmissive	/
3	Viewing direction(eye)	Free	/
4	Gray scale inversion direction	-	/
5	Resolution(H*V)	1280*800 Pixels	/
6	Module size (L*W*H)	232.90*154.60*6.55	mm
7	Active area (L*W)	216.96*135.60	mm
8	Pixel pitch (L*W)	0.1695* 0.1695	mm
9	Interface type	LVDS interface	/
10	Color Depth	16.7M	/
11	Module power consumption	TBD	W
12	Back light type	LED	/
13	Driver IC	HX8288-A/HX8695-B OR COMPATIBLE(TFT)	/
14	Weight	TBD	g

# 2. ABSOLUTE MAXIMUM RATINGS

Item	Symbol	Min.	Max.	Unit	Note
Power supply input voltage for TFT	VDD	-0.3	+3.9	V	
Power supply input voltage for CTP	VDD	-0.3	3.47	V	
Backlight current (normal temp.)	ILED	-	225	mA	
Operation temperature	Top	0	+50	°C	Note1
Storage temperature	Tst	-20	+60	°C	Note1
Humidity	RH	20%	90%	/	Note1

Note1 :

- 1).The relative humidity and temperature range are as below sketch,90%RH Max.
- 2).The maximum wet bulb temperature  $\cong 40^{\circ}\text{C}$  and without dewing.

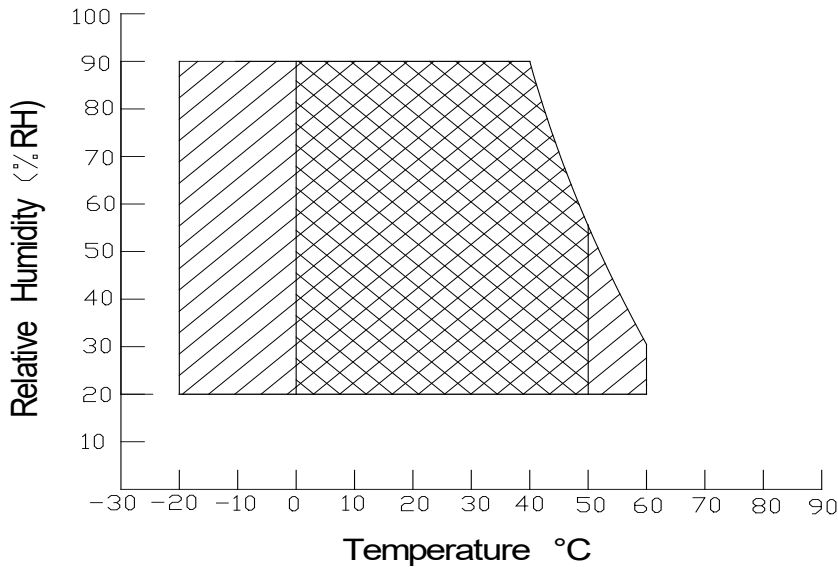

Operating Range



Storage Range

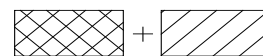

### 3. ELECTRICAL CHARACTERISTICS

#### TFT DC CHARACTERISTICS(at Ta=25°C)

Item	Symbol	Min.	Typ.	Max.	Unit	Note
Power supply input voltage	VDD	2.3	2.5	2.7	V	
Input voltage 'H' level	VIH	0.7VDD	-	3.6	V	
Input voltage 'L' level	VIL	0	-	0.3VDD	V	
Power supply current	IVDD	-	277	-	mA	
TFT gate on voltage	VGH	21.7	-	22.3	V	
TFT gate off voltage	VGL	-7.3	-	-6.7	V	
Analog power supply voltage	AVDD	8.0	8.2	8.4	V	
Differential input common mode voltage	Vcom	2.7	-	3.3	V	Note1
LVDS Differential input high Threshold voltage	RxvTH	-	-	+100	mV	RxvCM=1.2V
LVDS Differential input low Threshold voltage	RxvTL	-100	-	-	mV	
LVDS Differential input common mode voltage	RxvCM	0.7	-	1.6	V	
LVDS Differential voltage	VID	200	-	600	mV	

Note1 : The value is just the reference value. The customer can optimize the setting value by the different D-IC  
Vcom must be adjusted to optimize display quality, as Crosstalk and Contrast Ratio etc..

#### CTP DC CHARACTERISTICS(at Ta=25°C)

Item	Symbol	Min.	Typ.	Max.	Unit	Note
Power supply input voltage	VDD	2.66	3.3	3.47	V	Note2
Input Power ripple	Vpp	-	-	50	mV	
I/O Signal Voltage	VDDIO	-	1.8	-	V	Note2
Input voltage 'H' level	VIH	0.7VDDIO	-	VDDIO	V	
Input voltage 'L' level	VIL	VSS	-	0.3VDDIO	V	
Operating Current (Normal Mode)	IVDD	-	13	-	mA	
Operating Current (Sleep mode)	IVDD	-	-	-	mA	

Note2 : If you need more information of CTP, please refer to our Spec of CTP.

## 4. BACKLIGHT CHARACTERISTICS

(at Ta=25°C,RH=60%)

Item	Symbol	Min.	Typ.	Max.	Unit	Note
LED forward voltage	VF	19.6	21.7	23.8	V	
LED forward current	IF	-	180	-	mA	
LED power consumption	PLED	-	3.906	-	W	Note1
Number of LED	-		42		PCS	
Connection mode	-	7 in series 6 in parallel			/	
LED life-time	-	20000	30000	-	Hrs	Note2

Note1 : Calculator value for reference :  $IF \cdot VF = PLED$

Note2 : The LED life-time define as the estimated time to 50% degradation of initial brightness at Ta=25°C and IF =180mA. The LED lifetime could be decreased if operating IF is larger than 180mA.

## 5. TOUCH PANEL CHARACTERISTICS

(at Ta=25°C)

Item	Description	Remark
Product Structure	G+G	
Surface Hardness	≤6H	Pencil, Loading 500g, 45 deg
Ball-falling Test	≤80cm	Steel ball weight 64g
Touch Count Max	10 points	
I2C Slave Address*	0x5D	
Origin of Coordinate*	top left corner	

# 6. EXTERNAL DIMENSIONS

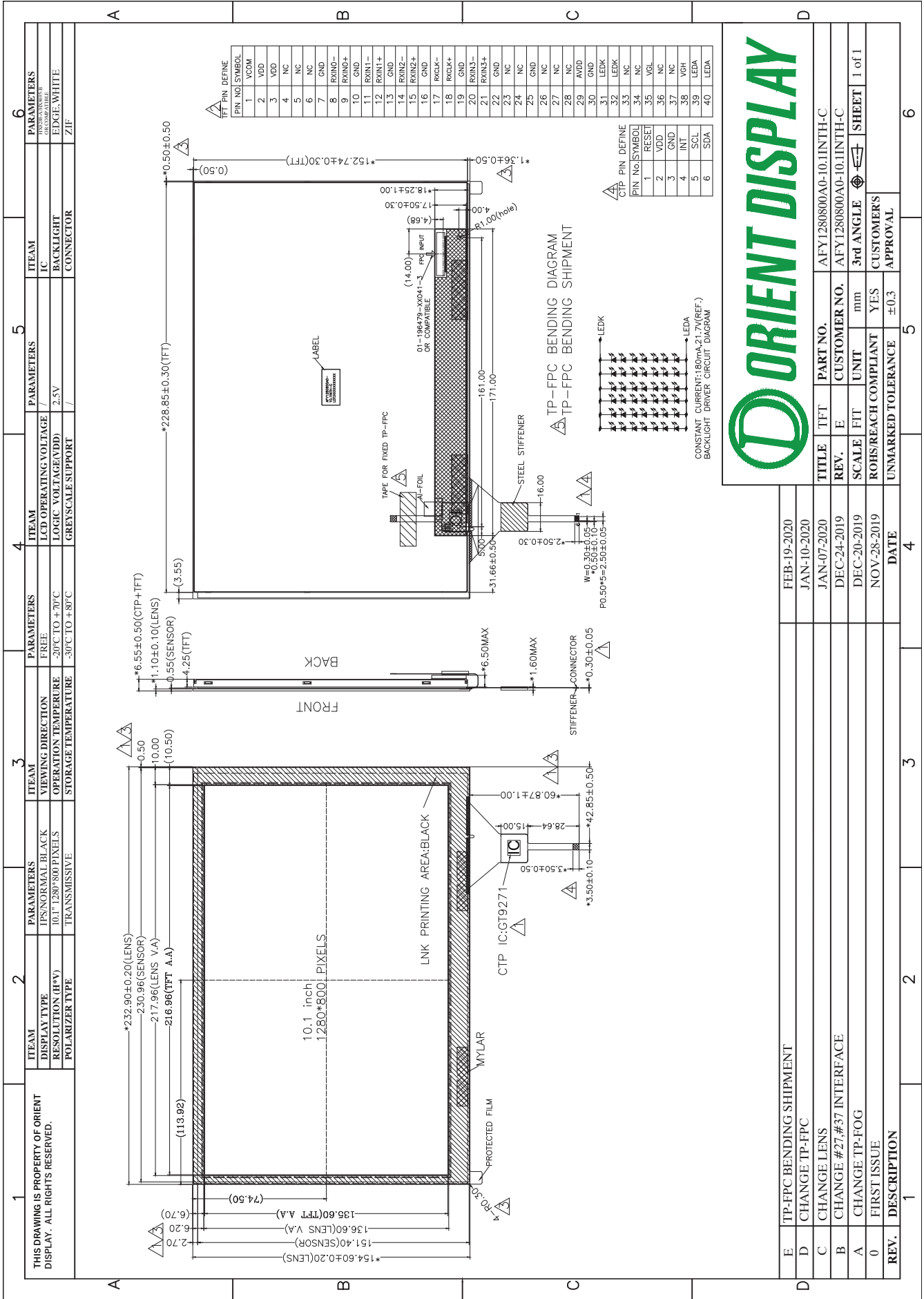

TITLE	TFT	PART NO.	CUSTOMER NO.
TP-FPC BENDING SHIPMENT		AFY1280800A0-10.1INTH-C	
CHANGE TP-FPC			
CHANGE LENS			
CHANGE #27, #37 INTERFACE			
CHANGE TP-FOG			
FIRST ISSUE			
REV.	DESCRIPTION	DATE	UNMARKED TOLERANCE
1			±0.3
2			
3			
4			
5			
6			

## 7. ELECTRO-OPTICAL CHARACTERISTICS

Item	Symbol	Condition	Min.	Typ.	Max.	Unit	Remark	Note
Response time	Tr+ Tf	-	-	25	50	ms	FIG.1	Note 1
Contrast ratio	Cr		600	800	-	-	FIG.2	Note 2
Surface luminance	Lv	$\theta=0^\circ$	600	900	-	cd/m <sup>2</sup>	FIG.2	Note 3
Luminance uniformity	Yu	$\theta=0^\circ$	75	80	-	%	FIG.2	Note 4
NTSC	-	$\theta=0^\circ$	-	50	-	%	FIG.2	Note 5
Viewing angle	$\theta$	$\varnothing=90^\circ$	75	85	-	deg	FIG.3	Note 6
		$\varnothing=270^\circ$	75	85	-	deg	FIG.3	
		$\varnothing=0^\circ$	75	85	-	deg	FIG.3	
		$\varnothing=180^\circ$	75	85	-	deg	FIG.3	
CIE (x,y) chromaticity	Red x	$\theta=0^\circ$ $\varnothing=0^\circ$ Ta=25°C	Typ -0.04	0.59	Typ +0.04	-	FIG.2 CIE1931	Note 5
	Red y			0.35		-		
	Green x			0.32		-		
	Green y			0.6		-		
	Blue x			0.15		-		
	Blue y			0.15		-		
	White x			0.32		-		
	White y			0.37		-		

### Note1. Definition of response time

The response time is defined as the LCD optical switching time interval between “White” state and “Black”state.Rise time (T<sub>ON</sub>) is the time between photo detector output intensity changed from 90% to 10%. And fall time (T<sub>OFF</sub>) is the time between photo detector output intensity changed from 10% to 90%. For additional information see FIG1.

### Note2.Definition of contrast ratio

Contrast ratio(Cr) is defined mathematically by the following formula. For more information see FIG.2.

$$\text{Contrast ratio} = \frac{\text{Luminance measured when LCD on the "White" state}}{\text{Luminance measured when LCD on the "Black" state}}$$

Measured at the center area of the LCD

### Note3.Definition of surface luminance

Surface luminance is the luminance with all pixels displaying white. For more information see FIG.2.

Lv = Average Surface Luminance with all white pixels(P1,P2,P3, .....,Pn)

### Note4.Definition of luminance uniformity

The luminance uniformity in surface luminance is determined by measuring luminance at each test position 1 through n, and then dividing the maximum luminance of n points luminance by minimum luminance of n points luminance.For more information see FIG.2.

$$Y_u = \frac{\text{Minimum surface luminance with all white pixels (P1,P2,P3,.....,Pn)}}{\text{Maximum surface luminance with all white pixels (P1,P2,P3,.....,Pn)}}$$

### Note5. Definition of color chromaticity (CIE1931)

CIE (x,y) chromaticity,The x,y value is determined by screen active area center position P5.For more information see FIG.2.

### Note6. Definition of viewing angle

Viewing angle is the angle at which the contrast ratio is greater than 10. angles are determined for the horizontal or x axis and the vertical or y axis with respect to the z axis which is normal to the LCD surface. For more information see FIG.3.

For viewing angle and response time testing, the testing data is base on Autronic-Melchers's ConoScope or DMS series Instruments or compatible. For contrast ratio, Surface Luminance, Luminance uniformity and CIE,the testing data is base on TOPCON's BM-5or BM-7 photo detector or compatible.



FIG.1. The definition of response Time

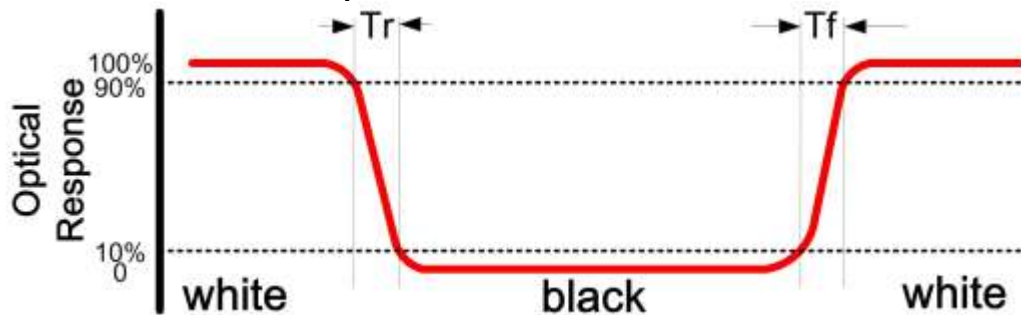

FIG.2. Measuring method for contrast ratio, surface luminance, luminance uniformity, CIE (x,y) chromaticity

H,V : Active area

Light spot size  $\varnothing=5\text{mm}$  (BM-7)50cm distance or compatible distance from the LCM surface to detector lens.

Test spot position : see Figure a.

measurement instrument : TOPCON's luminance meter BM-7 or compatible ,see Figure b.

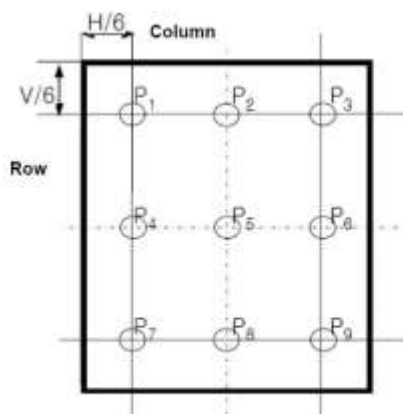

Figure a

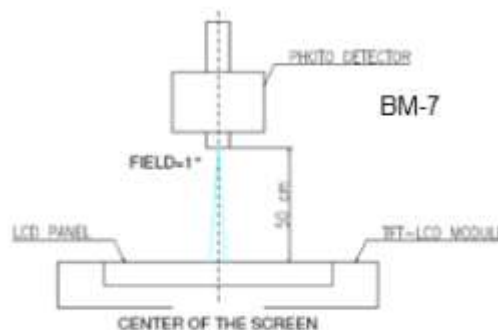
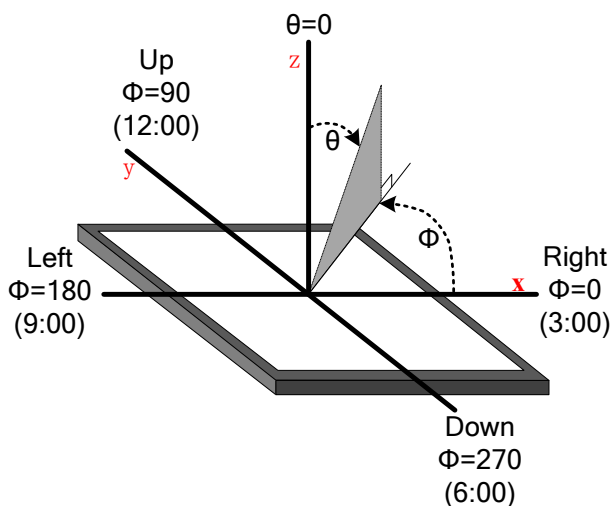

Figure b

FIG.3. The definition of viewing angle



## 8. INTERFACE DESCRIPTION

### TFT Module Interface description

Interface NO.	NAME	I/O or connect to	DESCRIPTION
1	VCOM	P	VCOM Voltage
2~3	VDD	P	LCD power supply
4	NC	/	No connection
5	NC	/	No connection
6	NC	/	No connection
7	GND	P	Power Ground
8	RXIN0-	I	LVDS CH0 data signal(-)
9	RXIN0+	I	LVDS CH0 data signal(+)
10	GND	P	Power Ground
11	RXIN1-	I	LVDS CH1 data signal(-)
12	RXIN1+	I	LVDS CH1 data signal(+)
13	GND	P	Power Ground
14	RXIN2-	I	LVDS CH2 data signal(-)
15	RXIN2+	I	LVDS CH2 data signal(+)
16	GND	P	Power Ground
17	RXCLK-	I	LVDS CLK data signal(-)
18	RXCLK+	I	LVDS CLK data signal(+)
19	GND	P	Power Ground
20	RXIN3-	I	LVDS CH3 data signal(-)
21	RXIN3+	I	LVDS CH3 data signal(+)
22	GND	P	Power Ground
23-24	NC	/	No connection
25	GND	P	Power Ground
26	NC	/	No connection
27	NC	/	No connection
28	NC	/	No connection
29	AVDD	P	Power for Analog circuit
30	GND	P	Power Ground

31	LEDK	P	Backlight Cathode
32	LEDK	P	
33	NC	/	No connection
34	NC	/	No connection
35	VGL	P	Gate off voltage
36	NC	/	No connection
37	NC	/	No connection
38	VGH	P	Gate on voltage
39	LEDA	P	Backlight Anode
40	LEDA	P	

#### CTP interface description

Interface No.	Name	I/O or connect to	Description
1	RESET	I	Reset low
2	VDD	P	Power for CTP
3	GND	P	Ground
4	INT	O	State change interrupt
5	SCL	I	Serial interface clock
6	SDA	I/O	Serial interface data

## 9. AC CHARACTERISTICS

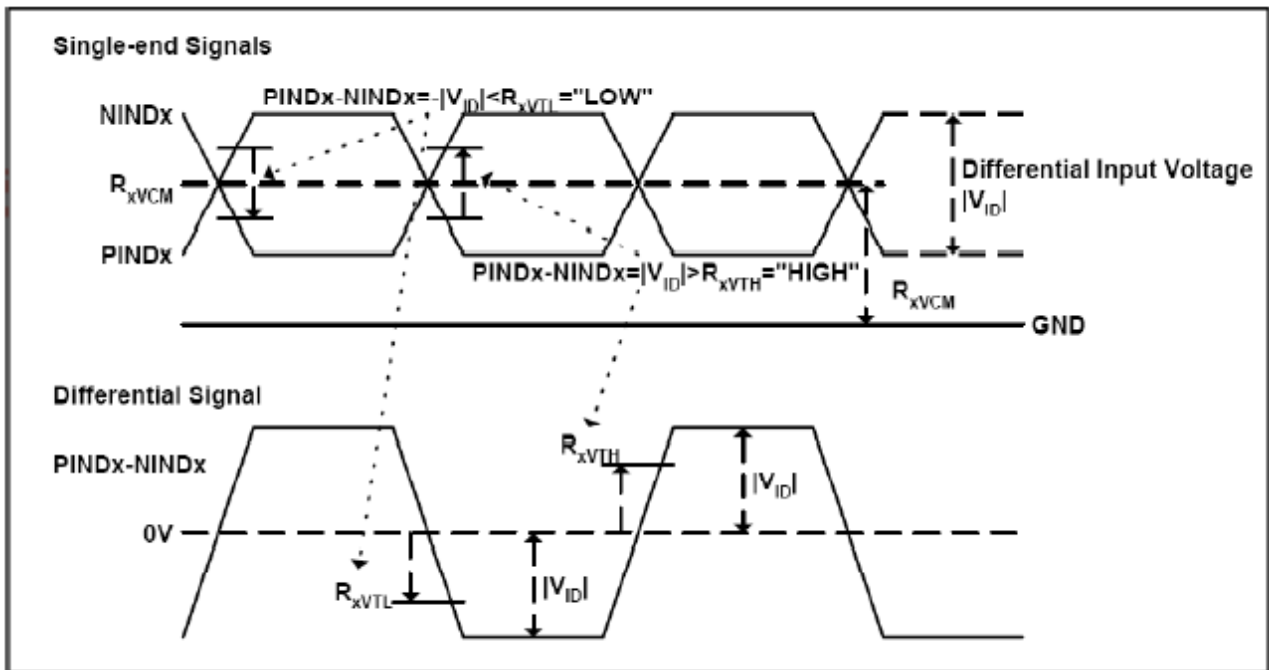

Timing table

Item	Symbol	Values			Unit	Remark
		Min.	Typ.	Max.		
Clock Frequency	$1/T_c$	68.9	71.1	73.4	MHz	Frame rate = 60Hz
Horizontal display area	$t_{HD}$	1280				
HS period time	$t_H$	1410	1440	1470	$T_c$	
HS Width +Back Porch +Front Porch	$t_{HW} + t_{HBP}$ $+t_{HFP}$	60	160	190	$T_c$	
Vertical display area	$t_{VD}$	800				
VS period time	$t_v$	815	823	833	$t_H$	
VS Width +Back Porch +Front Porch	$t_{vW} + t_{vBP}$ $+t_{vFP}$	15	23	33	$t_H$	

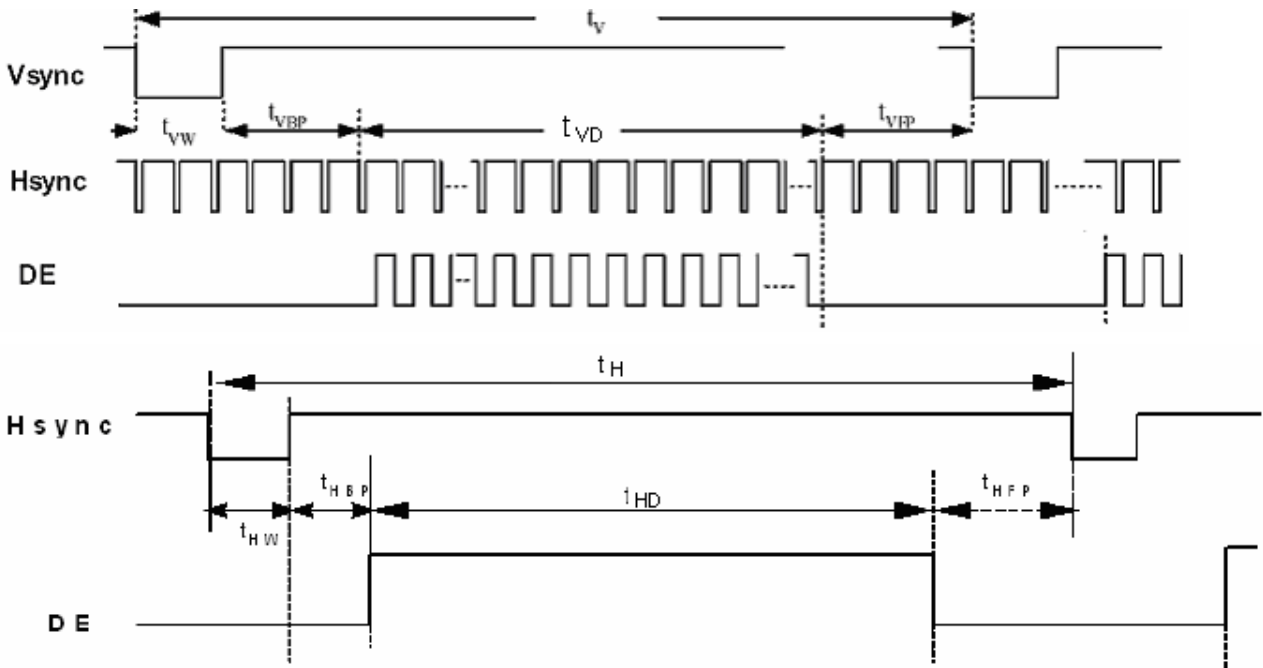

### LVDS Data Input Format

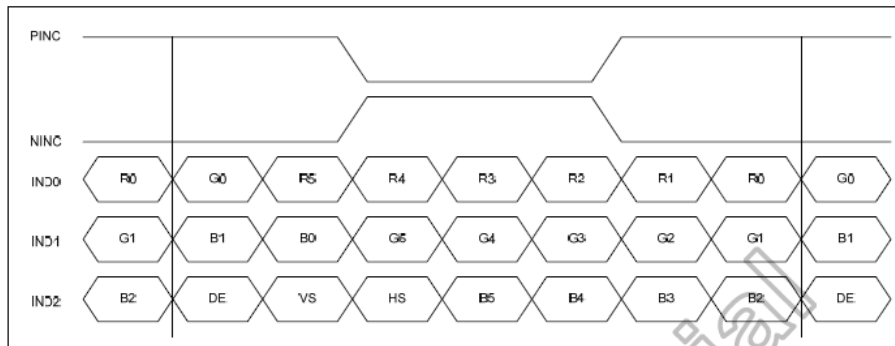
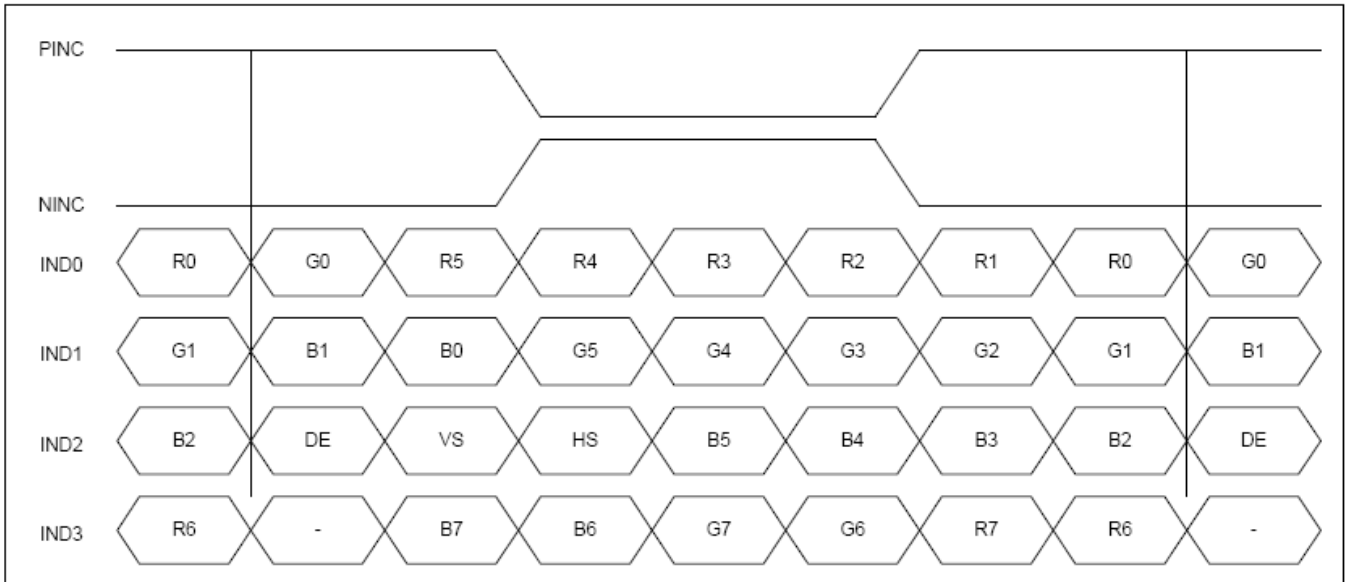

Figure 10.4: 6-bit LVDS input

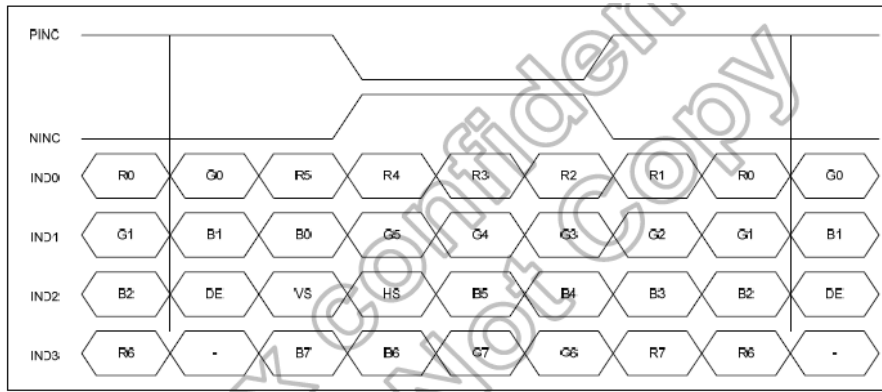

Figure 10.5: 8-bit LVDS input

• Horizontal timing

Parameter	Symbol	Spec.			Unit
		Min.	Typ.	Max.	
DCLK frequency	fclk	44.9	51.2	63	MHz
Horizontal display area	thd		1024		DCLK
HSD period	th	1200	1344	1400	DCLK
HSD pulse Width	thpw	1	-	140	DCLK
HSD back porch	thbp		160		DCLK
HSD front porch	thfp	16	160	216	DCLK

Table 10.5: HV mode horizontal timing (1024x600)

• Vertical timing

Parameter	Symbol	Spec.			Unit
		Min.	Typ.	Max.	
Vertical display area	tvd		600		$T_H$
VSD period	tv	624	635	750	$T_H$
VSD pulse width	tvpw	1	-	20	$T_H$
VSD back porch	tvbp		23		$T_H$
VSD front porch	tvfp	1	12	127	$T_H$

Table 10.6: HV mode vertical timing (1024x600)

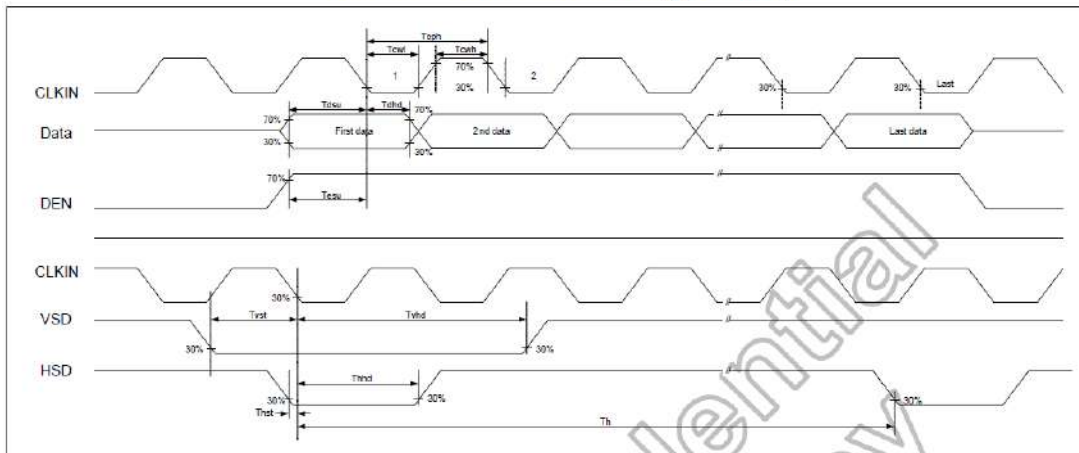
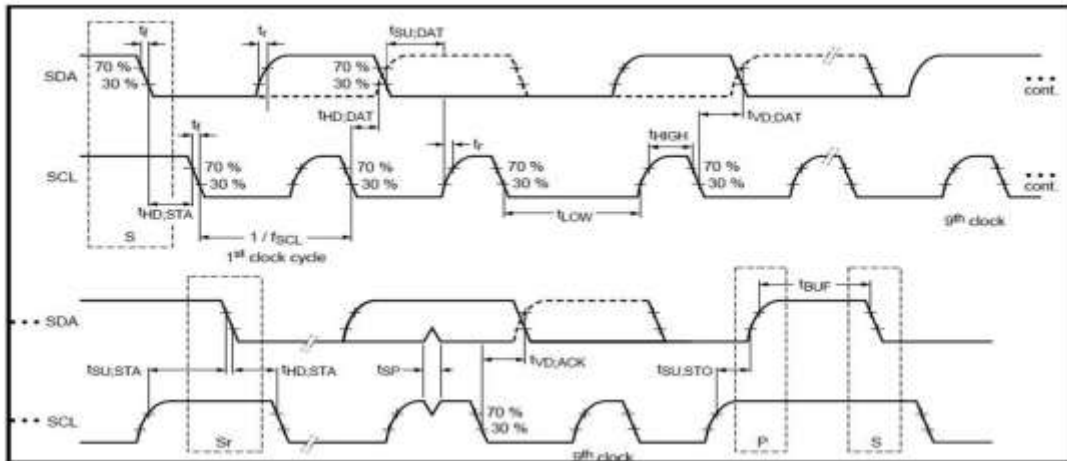

Figure 11.1: Input clock and data timing diagram

**CTP AC CHARACTERISTICS**



**Table 5-7: I2C AC Characteristics**

Parameter	Symbol	Standard-mode		Fast-mode		Unit
		Min	Max	Min	Max	
SCL clock frequency	$f_{SCL}$	0	100	0	400	kHz
Hold time START condition	$t_{HD:STA}$	4.0	-	0.6	-	us
LOW period of the SCL clock	$t_{LOW}$	4.7	-	1.3	-	us
HIGH period of the SCL clock	$t_{HIGH}$	4.0	-	0.6	-	us
Set-up time for a repeated START condition	$t_{SU:STA}$	4.7	-	0.6	-	us
Data hold time	$t_{HD:DAT}$	300	-	300	-	ns
Data set-up time	$t_{SU:DAT}$	250	-	100	-	ns
Rise time of both SDA and SCL signals (30% to 70%)	$t_r$	-	1000	20	300	ns
Fall time of both SDA and SCL signals (70% to 30%)	$t_f$	-	300	20	300	ns
Set-up time for STOP condition	$t_{SU:STO}$	4.0	-	0.6	-	us
Bus free time between a STOP and START condition	$t_{BUF}$	4.7	-	1.3	-	us
Capacitive load for each bus line	$C_b$	-	400	-	400	pF
Noise margin at the LOW level for each connected device	$V_{nL}$	$0.1V_{DD}$	-	$0.1V_{DD}$	-	V
Noise margin at the HIGH level for each connected device	$V_{nH}$	$0.2V_{DD}$	-	$0.2V_{DD}$	-	V

\*SCL = I2C Host must to support clock stretching mode for using 400 kHz.

## 10. POWER SEQUENCE

To prevent the device damage from latch up and Improve subjective display effect,the power ON/OFF sequence shown below must be followed.

### Power on timing sequence

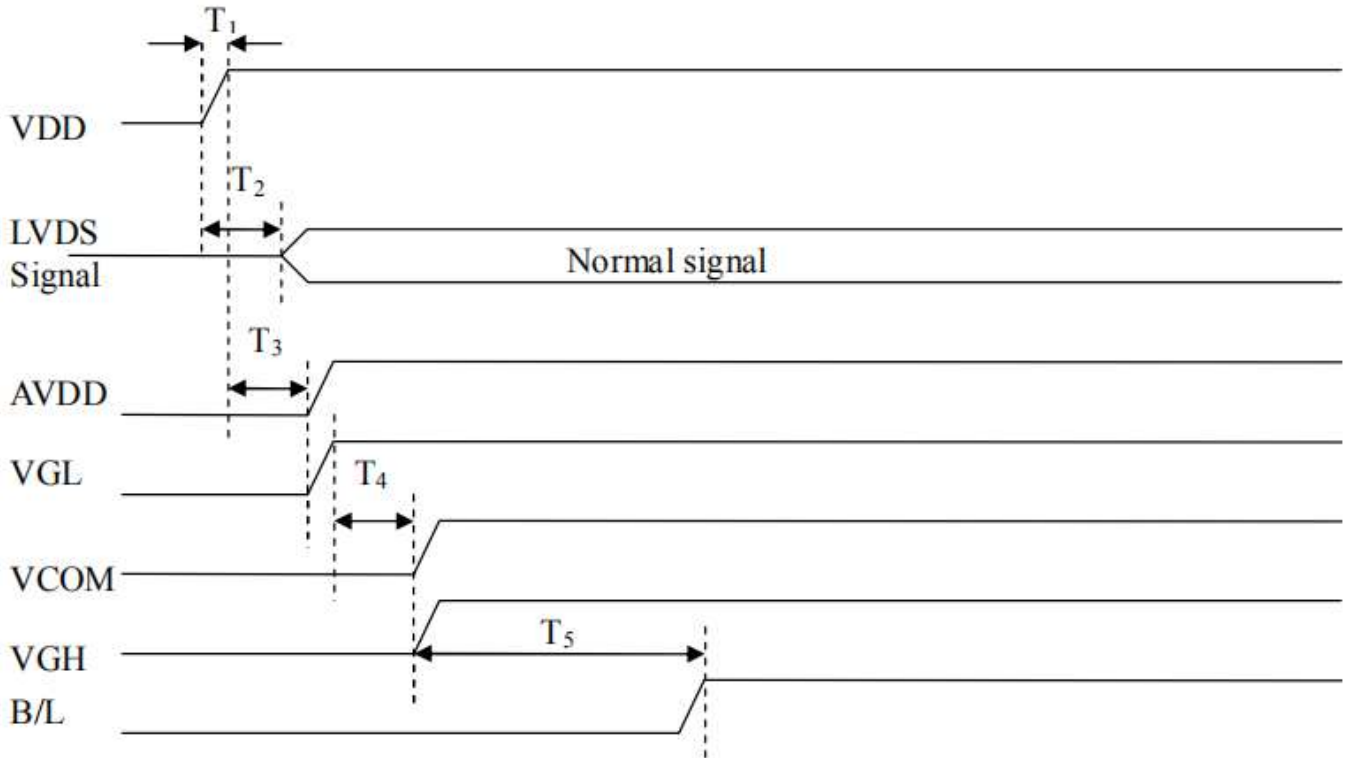

symbol	Value			Unit Min.
	Min.	Typ.	Max.	
T1	0.5	2	10	ms
T2	0	5	50	ms
T3	0	5	50	ms
T4	0	6	100	ms
T5	120	130	200	ms



### Power off timing sequence

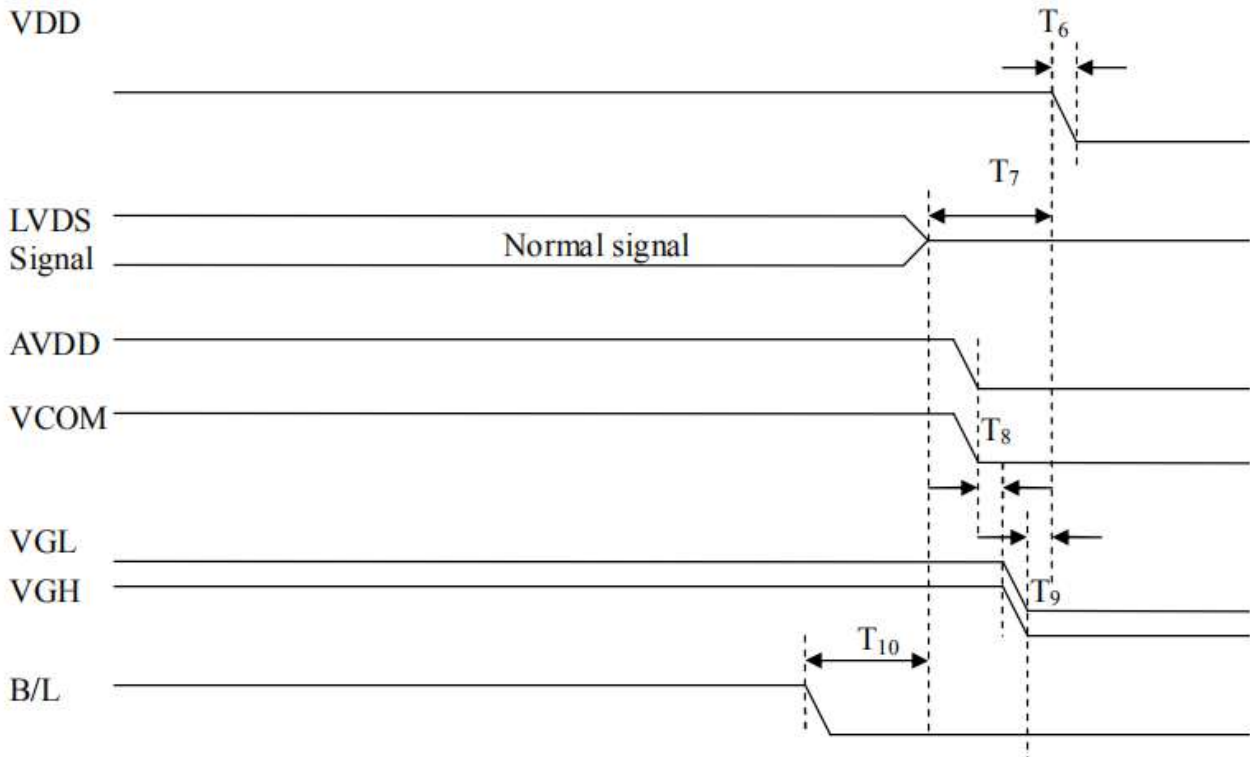

symbol	Value			Unit Min.
	Min.	Typ.	Max.	
T <sub>6</sub>	0.5	2	10	ms
T <sub>7</sub>	0	7	50	ms
T <sub>8</sub>	0	5	10	ms
T <sub>9</sub>	0	1	10	ms
T <sub>10</sub>	0	2	100	ms

## CTP POWER SEQUENCE Power On

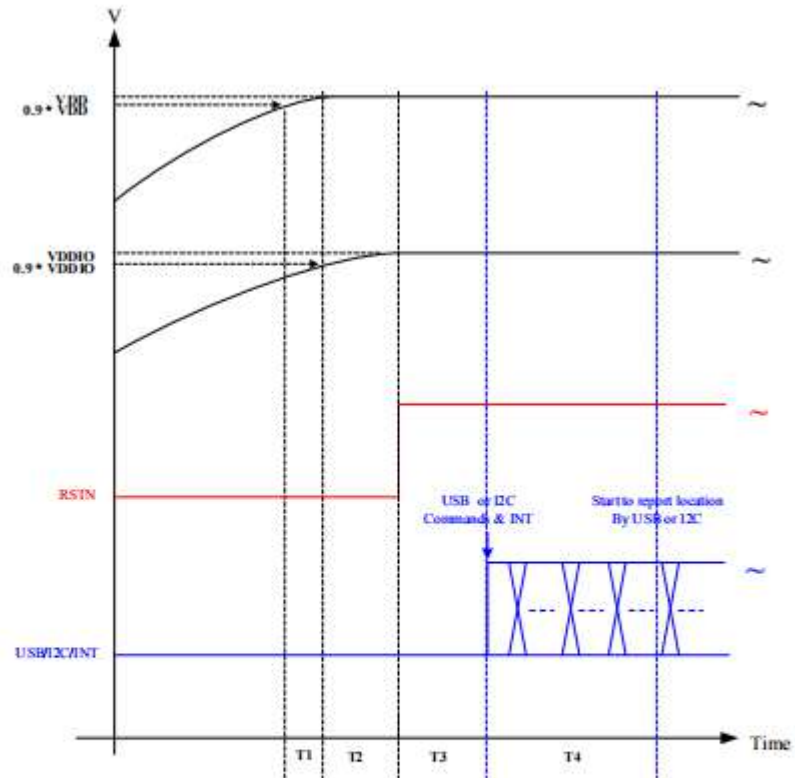

1. T1: the time difference between 0.9\*VDD and 0.9\*VDDIO. T1 must be  $\geq 0$  sec.
2. T2: the time difference between 0.9\*VDDIO and RSTN. T2 must be  $\geq 200$  us.
3. T3: the time difference between RSTN and Commands. T3 must be  $\geq 150$  ms.
4. T4: IC start to report point location to host. T4 must be  $\geq 300$  ms.

## Power Off

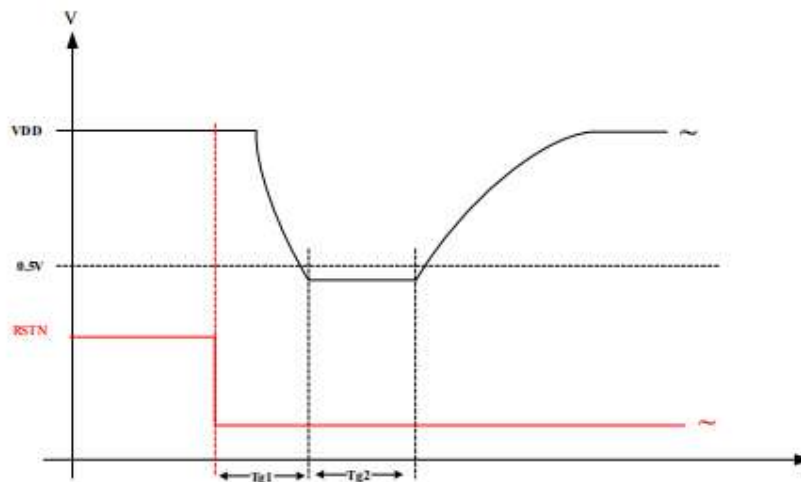

- Tg1 : the time difference between power-off and power-on. Tg1 must be  $> 10\mu\text{s}$ .
- Tg2 : the time difference between power-off and power-on. Tg2 must be  $> 10\mu\text{s}$ .

**Note.** During the power off time, the VDD must be lower than 0.5V that make sure the touch controller have been correctly reset.

## 11. RELIABILITY TEST CONDITIONS

No.	Test item	Test condition	Inspection after test	
11.1	High temperature storage test	+60°C/240 hours	Inspection after 2~4hours storage at room temperature, the sample shall be free from defects : 1.Current changing value before test and after test is 50% larger; 2. Function defect : Non-display,abnormal-d isplay,missing lines, Short lines,I/O corrosion; 3.Visual defect : Air bubble in the LCD,Seal leak,Glass crack.	
11.2	Low temperature storage test	-20°C/240 hours		
11.3	High temperature operating test	+50°C/120 hours		
11.4	Low temperature operating test	0°C/120 hours		
11.5	Temperature cycle storage test	-20°C ~ 25°C ~ +60°C/10cycles (30min.) (10min.) (30min.)		
11.6	High temperature high humidity test	+50°C*90% RH/120 hours		
11.7	Vibration test	Frequency : 250 r/min Amplitude : 1 inch Time: 45min		
11.8	Drop test	Drop direction: 1 corner/3 edges/6 sides 10 time		
		Packing weight(kg)		Drop height(cm)
		<11		80±1.6
		11≤G<21	60±1.2	
		21≤G<31	50±1.0	
31≤G<40	40±0.8			
11.9	ESD test	Air discharge: ±8KV, 10time Contact discharge: ±4KV, 10time		

**Remark :**

- 1.The test samples should be applied to only one test item.
- 2.Sample size for each test item is 3~5pcs.
- 3.For High temperature high humidity test, Pure water(Resistance>10MΩ) should be used.
- 4.In case of malfunction defect caused by ESD damage, if it would be recovered to normal state after resetting, it would be judged as a good part.
- 5.B/L evaluation should be excepted from reliability test with humidity and temperature: Some defects such as black spot/blemish can happen by natural chemical reaction with humidity and Fluorescence B/L has.
- 6.Failure judgment criterion: Basic specification, Electrical characteristic, Mechanical characteristic, Optical characteristic.
- 7.After the reliability test, the product only guarantees operation, but don't guarantee all of the cosmetic specification.

## 12. INSPECTION CRITERION

### 12.1. Objective

The CTP test criterion are set to formalize CTP quality standards for ODNA with reference to those of the customer for inspection, release and acceptance of finished CTP products in order to guarantee the quality of CTP products required by the customer.

### 12.2. Scope

This specification is applicable to capacitive touch panel manufactured by ODNA.

### 12.3. Equipment for Inspection

lamp-box、ionizing fan、10X microscopes、film card、alcohol/oil ether/acetone、finger cots、vernier caliper、anti-static wrist straps、microcalliper、feeler、pencil hardness tester、spectrophotometer、drop ball test,etc.

### 12.4. Sampling Plan and Reference Standards

Sampling plan:Refer to National Standard GB/T 2828.1---2012/ISO2859-1:1999, level II of normal levels:

Product Category	Industrial
AQL	MA=0.25 MI=0.65

### 12.5. Inspection

#### 5.Conditions and Inspection Reference

12.5.1. Inspection environment: temperature: 23±3°C; humidity: 40~70%RH; cleanness: 10000 grade;

12.5.2 .Inspection distance: 30cm±5cm;

12.5.3. Inspection angle: vertical rotate angle: ±45°, up->down;horizontal rotate angle:±45°,left->right

12.5.4 Ambient Illumination:

(1) appearance inspection without power on: Inspection luminance is 800~1200Lux

(2) functional inspection: 200~500 Lux for light on inspection

12.5.5 background: white/black

12.5.6. Inspection time : 10~15s/ pcs;

**Black Booth or Black Background**

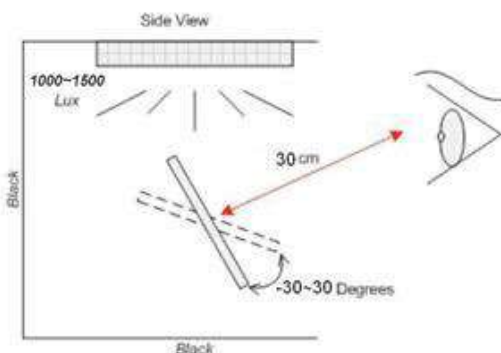

12.5.7.2 VA area: Visual Windows area (refer to below sketch Red blank);

12.5.7.3 Area A: visual area from front side view((refer to below sketch Blue blank))

12.5.7.4 Area B: four sides and FPC area((refer to below sketch Green blank))

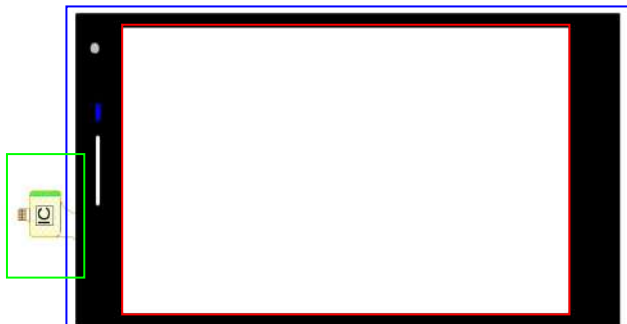

12.5.7.5 Undefined items or other special items, refer to mutual agreement and limited sample.If criterion does not match product specifications/ technical requirement, both should be subject to special inspection criterion agreed by customer.

12.5.8 Defect define:

12.5.8.1 Defect in AA area: pixel defect, function defect (no display, miss line, dark line, wrong polarizer angle, flicker, abnormal display, dim/bright display, Contrast ratio, dot defect(white dot, black dot, dark dot,

Convex-concave point, bubble, foreign material), visual line defect(fiber, scratch, foreign material) , stain and so on

12.5.8.2 Defect in VA area: dot defect(white dot, black dot, dark dot, Convex-concave point, bubble, foreign material), visual line defect(fiber, scratch, foreign material) , stain and so on

12.5.8.3 Defect in A area: Line defect ( scratch、 soft flocks、 fibre ) 、 dot defect ( white dot、 black dot、 same color dot、 different color dot、 dust、 bubble ) 、 surface stain、 pin-hole、 light leak、 scratch.

12.5.8.4 Defect in B area: Broken、 crack/chipping、 FPC defect

12.5.9 Undefined items or other special items, refer to mutual agreement and limited sample. If criterion does not match product specifications/ technical requirement, both should be subject to special inspection criterion agreed by customer.

12.5.10.To the touch screen and display size of different products: The defects of TFT screen are determined according to the corresponding TFT screen size.; The defects in TP VA area are determined according to the corresponding criteria of the corresponding VA area, and the outside of the VA area is determined by the dimension standard.

## 12.6. Defects and Acceptance Standards

12.6.1 Function defect for TP

12.6.1 Electrical properties test

Check in ODNA tester. The program will release result automatically. There are “OK” 、 “PASS” 、 “NG” and the final judgment must be “OK” “PASS” ,and we need to pass the draw line test.

Refer to 《\*\*serise IC test program》

No.	Defects	Descriptions	Accepted standard	MAJ	MIN
12.6.1.1	Short	Measured data has much difference compared with normal;line is not stable	Reject	√	
12.6.1.2	Open	Measured data has no change.Line is open	Reject	√	
12.6.1.3	No reaction	No reaction and there is no line in screen	Reject	√	
12.6.1.4	Mis-display/ abnormal display	Screen has display but line is open or bent	Reject	√	
12.6.1.5	Button no reaction	Press the button but no reaction	Reject	√	
12.6.1.6	Button not correct	Press the button .Reaction is not stable	Reject	√	

12.6.2 Appearance inspection

12.6.2.1 Normal lens dot/line defect

12.6.2.1.1.Industrial product point/line standard

Defect	≦5”	5~10”	10~15”	>15”	Accepted standard	MAJ	MIN
S/C,line defect	Tactile S/C->NG	Tactile S/C->NG	Tactile S/C->NG	Tactile S/C->NG	Reject		√
W:width L:length	W≦0.05mm, ->OK; Density is high ->NG	W≦0.05mm, ->OK; Density is high ->NG	W≦0.05mm, ->OK; Density is high ->NG	W≦0.08mm, ->OK; Density is high ->NG	Accept		√
	0.05mm<W ≦0.10mm, L ≦8mm quantity≦3	0.05mm<W≦ 0.1mm, L≦ 10mm quantity≦6	0.05mm<W≦ 0.1mm, L≦ 20mm quantity≦5	0.08mm<W ≦0.1mm, L≦ 25mm quantity≦5	Accept		√

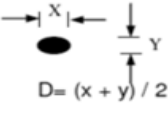
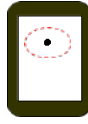
	distance > 10mm	distance > 10mm	distance > 10mm	distance > 10mm			
	W > 0.10mm L > 8mm	W > 0.1mm L > 10mm	W > 0.1mm L > 20mm	W > 0.1mm L > 25mm	Reject		✓
Dot defect D: Diameter  	D ≤ 0.15mm, ->OK;	D ≤ 0.15mm, ->OK;	D ≤ 0.20mm, ->OK;	D ≤ 0.30mm, ->OK;	Accept		✓
	0.15mm < D ≤ 0.25mm quantity ≤ 3 0.25mm < D ≤ 0.3mm quantity ≤ 1 distance > 10mm	0.15mm < D ≤ 0.30mm quantity ≤ 3 0.30mm < D ≤ 0.40mm quantity ≤ 1 distance > 10mm	0.20mm < D ≤ 0.50mm quantity ≤ 5 distance > 10mm	0.30mm < D ≤ 0.50mm quantity ≤ 5 distance > 10mm	Accept		✓
	D > 0.30mm	D > 0.40mm	D > 0.50mm	D > 0.50mm	Reject		✓



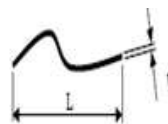
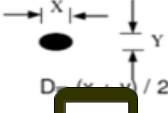
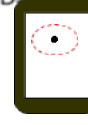

Note: within 1 mm, if there are more than three (round shape), two (linear) or round shape and line shape, it is called density;

#### 12.6.2.1.2. Non-industrial product point/line standard

Defect	≤ 5"	5~10"	10~15"	> 15"	Accepted standard	MAJ	MIN
S/C ,line defect W:width L:length 	Tactile S/C->NG	Tactile S/C->NG	Tactile S/C->NG	Tactile S/C->NG	Reject		✓
	W ≤ 0.03mm, ->OK; Density is high ->NG	W ≤ 0.05mm, ->OK; Density is high ->NG	W ≤ 0.05mm, ->OK; Density is high ->NG	W ≤ 0.05mm, ->OK; Density is high ->NG	Accept		✓
	0.03mm < W ≤ 0.08mm, L ≤ 5mm quantity ≤ 2	0.05mm < W ≤ 0.1mm, L ≤ 8mm quantity ≤ 3	0.05mm < W ≤ 0.1mm, L ≤ 10mm quantity ≤ 3	0.05mm < W ≤ 0.1mm, L ≤ 20mm quantity ≤ 5	Accept		✓
	W > 0.08mm L > 5mm	W > 0.1mm L > 8mm	W > 0.1mm L > 10mm	W > 0.1mm L > 20mm	Reject		✓
Dot defect D: Diameter  	D ≤ 0.10mm, ->OK;	D ≤ 0.15mm, ->OK;	D ≤ 0.15mm, ->OK;	D ≤ 0.2mm, ->OK;	Accept		✓
	0.10mm < D ≤ 0.2mm quantity ≤ 2 0.2 < D ≤ 0.25, quantity ≤ 1 distance > 10mm	0.15mm < D ≤ 0.25mm quantity ≤ 3 0.25 < D ≤ 0.3 quantity ≤ 1 distance > 10mm	0.15mm < D ≤ 0.30mm quantity ≤ 3 0.30mm < D ≤ 0.40mm quantity ≤ 1 distance > 10mm	0.20mm < D ≤ 0.50mm quantity ≤ 5 distance > 10mm	Accept		✓
	D > 0.25mm	D > 0.30mm	D > 0.40mm	D > 0.50mm	Reject		✓

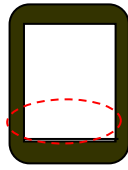
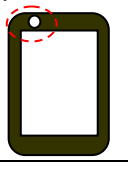
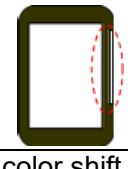
Note: the scratches, lines, and points are all density and unreceiving (two or more in 1MM are called density);

12.6.2.2. Normal lens (thickness < 1.8mm, surface without AG/AR treatment)Screen printing standard

Defect	Description	Accepted standard	MAJ	MIN
Printing zigzag 	zigzag width which is almost the same with VA area $W \leq 0.15\text{mm}$	Accept		✓
	zigzag width which is almost the same with VA area $W > 0.15\text{mm}$	Reject		✓
Wire mark 	$\leq 0.15\text{mm}$	Accept		✓
	$> 0.15\text{mm}$	Reject		✓
Ink pinhole 	Invisible with reflector light	Accept		✓
Ink film defect	Ink film:s/c、 soft flocks、 fibre Ink film stain/color shift:refer to limited sample Ink film foreign material/scratch: refer to 6.1.1 visible area judgment	Accept		✓
Ink light leak 	LENS thickness $\leq 0.7\text{mm}$ : The leakage width of the edge area $\leq 0.15\text{mm}$ , Unilateral light-leaking $\leq 1$ LENS thickness $> 0.7\text{mm}$ : The leakage width of the edge area $\leq 0.25\text{mm}$ , Unilateral light-leaking $\leq 1$	Accept		✓
Ink color shift	Refer to limited sample			✓
font、 glass silver line (ink area) width $\geq 0.2\text{mm}$  	$D \leq 0.20\text{mm}$ ; $N \leq 2 \uparrow$	Accept		✓
	$D > 0.20\text{mm}$	Reject		✓
	Refer to limited sample, if it' s out of spec	Reject		✓
word/color error	Word or color or position is different from drawing and sample.	Reject	✓	
word missing width $\leq 0.2\text{mm}$ 	height, $a \leq 1/4h$ , width $\leq 1/2w$	Accept		✓

Font thickness different and color nonuniform 	Refer to limited sample, if it's out of spec	Reject		✓
IR/video/ Receive hole /Button hole	Irregular hole , offside, refer to drawing	Accept		✓
	Foreign material/scratch exist in hole, refer to 6.1.1	Reject		✓
LENS broadside foreign material	Width $\leq$ 0.15mm	Accept		✓
Ink spill	LENS broadside or receive hole or button hole have ink spill defect, refer to limited sample.	Accept		✓

### 12.6.2.3 Normal lens breakdown standard

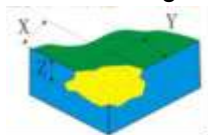
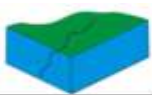
Defect	$\leq 5''$	5~10''	10~15''	>15''	Accepted standard	MAJ	MIN
LENS breakage 	X $\leq$ 0.3mm, Y $\leq$ 0.3mm, one side $\leq$ 1	X $\leq$ 0.3mm, Y $\leq$ 0.4mm, one side $\leq$ 1	X $\leq$ 0.4mm, Y $\leq$ 0.4mm, one side $\leq$ 1	X $\leq$ 0.5mm, Y $\leq$ 0.5mm, one side $\leq$ 1	Accept		✓
	X > 0.3mm, Y > 0.3mm	X > 0.3mm, Y > 0.4mm	X > 0.4mm, Y > 0.4mm	X > 0.5mm, Y > 0.5mm	Reject		✓
Sensor breakage	Not affect ITO line, not lengthen, function test is OK And be non-visual after attaching Lens				Accept		✓
	affect ITO line and be visual				Reject		✓
Glass crack 	Crack lengthen to outside				Accept		✓
	Crack lengthen to inside				Reject		✓

### 12.6.2.4 special lens standard

#### 12.6.2.4.1 AG/AR processing LENS standard

Thick ness	Defect type	S < 5 inch	5 $\leq$ S < 10 inch	10 $\leq$ S < 15 inch	15 inch $\leq$ S	accept ance criterio n
thickn ess < 1.8m		W $\leq$ 0.05, Ignore, dense except	W $\leq$ 0.05, Ignore, dense except	W $\leq$ 0.05, Ignore, dense except	W $\leq$ 0.05, Ignore, dense except	accept



m	Scratch: W: width, L: length	$0.05\text{mm} < W \leq 0.1\text{mm}$ , $L \leq 12\text{mm}$ , $N \leq 3$	$0.05\text{mm} < W \leq 0.1\text{mm}$ , $L \leq 15\text{mm}$ , $N \leq 3$	$0.05\text{mm} < W \leq 0.1\text{mm}$ , $L \leq 20\text{mm}$ , $N \leq 4$	$0.05\text{mm} < W \leq 0.1\text{mm}$ , $L \leq 25\text{mm}$ , $N \leq 5$	accept		
		$0.1\text{mm} < W \leq 0.15\text{mm}$ , $L \leq 12\text{mm}$ , $N \leq 2$	$0.1\text{mm} < W \leq 0.15\text{mm}$ , $L \leq 15\text{mm}$ , $N \leq 2$	$0.1\text{mm} < W \leq 0.15\text{mm}$ , $L \leq 20\text{mm}$ , $N \leq 3$	$0.1\text{mm} < W \leq 0.15\text{mm}$ , $L \leq 25\text{mm}$ , $N \leq 4$	accept		
		$W > 0.15\text{mm}$ , $L > 12\text{mm}$	$W > 0.15\text{mm}$ , $L > 15\text{mm}$	$W > 0.15\text{mm}$ , $L > 20\text{mm}$	$W > 0.15\text{mm}$ , $L > 25\text{mm}$	reject		
	Dot: D: diameter	$D < 0.2\text{mm}$ , ignore, dense except	$D < 0.2\text{mm}$ , ignore, dense except	$D < 0.2\text{mm}$ , ignore, dense except	$D < 0.2\text{mm}$ , ignore, dense except	accept		
		$0.2\text{mm} \leq D < 0.3\text{mm}$ , $N \leq 3$	$0.2\text{mm} \leq D < 0.3\text{mm}$ , $N \leq 3$ , $0.3\text{mm} \leq D < 0.4\text{mm}$ , $N \leq 1$	$0.2\text{mm} \leq D < 0.4\text{mm}$ , $N \leq 3$ , $0.4\text{mm} \leq D < 0.5\text{mm}$ , $N \leq 1$	$0.2\text{mm} \leq D < 0.4\text{mm}$ , $N \leq 3$ , $0.4\text{mm} \leq D < 0.6\text{mm}$ , $N \leq 2$	accept		
		Note: point defect, the diameter is based on the etching defect, not including the ripple marks on the etching defect						
		thickness $\geq 1.8\text{mm}$	Scratch: W: width, L: length	$W \leq 0.05$ , ignore, dense except	$W \leq 0.05$ , ignore, dense except	$W \leq 0.05$ , ignore, dense except	$W \leq 0.05$ , ignore, dense except	accept
				$0.05\text{mm} < W \leq 0.1\text{mm}$ , $L \leq 12\text{mm}$ , $N \leq 3$	$0.05\text{mm} < W \leq 0.1\text{mm}$ , $L \leq 15\text{mm}$ , $N \leq 3$	$0.05\text{mm} < W \leq 0.15\text{mm}$ , $L \leq 20\text{mm}$ , $N \leq 4$	$0.05\text{mm} < W \leq 0.2\text{mm}$ , $L \leq 25\text{mm}$ , $N \leq 5$	accept
$0.1\text{mm} < W \leq 0.15\text{mm}$ , $L \leq 12\text{mm}$ , $N \leq 2$	$0.1\text{mm} < W \leq 0.2\text{mm}$ , $L \leq 15\text{mm}$ , $N \leq 2$			$0.15\text{mm} < W \leq 0.25\text{mm}$ , $L \leq 20\text{mm}$ , $N \leq 2$	$0.2\text{mm} < W \leq 0.3\text{mm}$ , $L \leq 25\text{mm}$ , $N \leq 2$	accept		
		$D < 0.2\text{mm}$ , ignore, dense except	$D < 0.2\text{mm}$ , ignore, dense except	$D < 0.2\text{mm}$ , ignore, dense except	$D < 0.2\text{mm}$ , ignore, dense except	accept		
		$0.2\text{mm} \leq D < 0.3\text{mm}$ , $N \leq 3$	$0.2\text{mm} \leq D < 0.3\text{mm}$ , $N \leq 3$ , $0.3\text{mm} \leq D < 0.4\text{mm}$ , $N \leq 1$	$0.2\text{mm} \leq D < 0.4\text{mm}$ , $N \leq 3$ , $0.4\text{mm} \leq D < 0.5\text{mm}$ , $N \leq 2$	$0.2\text{mm} \leq D < 0.4\text{mm}$ , $N \leq 3$ , $0.4\text{mm} \leq D < 0.6\text{mm}$ , $N \leq 3$	accept		
		$D \geq 0.3\text{mm}$	$D \geq 0.4\text{mm}$	$D \geq 0.5\text{mm}$	$D \geq 0.6\text{mm}$	reject		
		Note: point defect, the diameter is based on the etching defect, not including the ripple marks on the etching defect						
All the thickness	Edge breakage	$X \leq 0.5\text{mm}$ , $Y \leq 0.5\text{mm}$ , $Z \leq 1/2 T$ One-sided only allows 1	$X \leq 0.5\text{mm}$ , $Y \leq 0.5\text{mm}$ , $Z \leq 1/2 T$ One-sided only allows 1	$X \leq 0.5\text{mm}$ , $Y \leq 0.5\text{mm}$ , $Z \leq 1/2 T$ One-sided only allows 2	$X \leq 0.5\text{mm}$ , $Y \leq 0.5\text{mm}$ , $Z \leq 1/2 T$ One-sided only allows 2	accept		
	Corner breakage	$X \leq 0.5\text{mm}$ , $Y \leq 0.5\text{mm}$ , $Z \leq 1/2 T$ , unilateral allowable: $N \leq 1$ ;						
	Glass crack	The crack is extended to the outer edge and is calculated according to the collapse; Progressive cracks extending to the inner edge are not allowed						
	Sand edge	$W \leq 0.3\text{mm}$ , ignore; $W > 0.3\text{mm}$ , reject						
	Sawtooth	The width of the sawtooth near the VA area : $W \leq 0.3\text{mm}$ , allow, $W > 0.3\text{mm}$ , reject;						
	Main color ink light leak	Edge area leakage width : $W \leq 0.25\text{mm}$ Only unilateral leakage is allowed; Edge area leakage width $> 0.25\text{mm}$ reject						
	Screen printing	$W \leq 0.15\text{mm}$ , allow, $W > 0.15\text{mm}$ , reject						
	Main color ink pinhole	Outside the 2mm edge of the VA area, Reflection conditions check for invisible permission, Any pinholes are not allowed within 2mm of the area of the VA area						
	Defects in the main color ink layer	The ink layer has fiber, impurity reference visual area standard; Standards for scratch within the ink layer: $0.05\text{mm} < W \leq 0.08\text{mm}$ , $L \leq 3\text{mm}$ , $N \leq 1$ , allow; $W > 0.08\text{mm}$ , $L > 3\text{mm}$ , reject						
	Ink pattern spillage	$D \leq 0.15\text{mm}$ ; $N \leq 2$ , allow; $D > 0.15\text{mm}$ , reject						

Ink pattern gap	Gap width $\leq 1/4h$ (h is the height of the pattern) or gap width $\leq 1/2w$ (w is the width of the pattern) allow
Dirty mark	Printing main color stain $W \leq 0.3\text{mm}$ ignore, Not visible under fluorescent lamps, allow; Printing main color stain $W > 0.3\text{mm}$ , visible under fluorescent lamps, reject
IR semi-permeable area ink pinhole	$D \leq 0.15\text{mm}$ , $N \leq 1$ , allow; $D > 0.15\text{mm}$ , reject;
IR semi-permeable area ink color difference	Reflector is not visible in black background, acceptable
IR semi-permeable area ink internal impurities	$D \leq 0.35\text{mm}$ ; $N \leq 5$ , allow; $D > 0.35\text{mm}$ ; $N > 5$ , reject
Dander foreign body	$W \leq 0.3\text{mm}$ , $L \leq 10\text{mm}$ , $N \leq 3$ , allow; $W > 0.3\text{mm}$ , reject ;
Appearance	The surface is attached to a slight wipes smudge acceptable, and the air gun can be blown off of the dandruff acceptable
AG/AR Glass color difference	Refer to the technical signature
Note: 5 or more defects within 10mm are called intensive. (intensive defects: not allowed). The spacing of all defects is 10mm	

12.6.2.4.2 Lens thickness is greater than or equal to 1.8mm product(with/without ink printing)

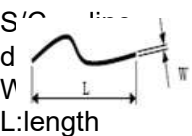
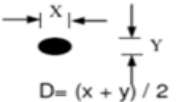
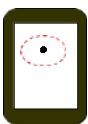
Defect	$\leq 5''$	5~10''	10~15''	>15''	Accepted standard
	$W \leq 0.08$ ignore except dense		$W \leq 0.1$ ignore except dense		accept
	$0.08 < W \leq 0.15$ $L \leq 18\text{ mm}; N \leq 3$ $0.15 < W \leq 0.3$ $L \leq 18; N \leq 2$	$0.08 < W \leq 0.15$ $L \leq 20\text{mm}; N \leq 3$ $0.15 < W \leq 0.3$ $L \leq 20\text{mm}; N \leq 3$	$0.1 < W \leq 0.2$ $L \leq 25\text{mm}; N \leq 4$ $0.2 < W \leq 0.5$ $L \leq 25\text{mm}; N \leq 3$	$0.1 < W \leq 0.2$ $L \leq 30\text{mm}; N \leq 5$ $0.2 < W \leq 0.5$ $L \leq 30\text{mm}; N \leq 4$	accept
	$W > 0.3, L > 18$	$W > 0.3, L > 20$	$W > 0.5\text{mm}, L > 25\text{mm}$	$W > 0.5\text{mm}, L > 30\text{mm}$	reject
Dot defect D: Diameter  	$D \leq 0.2\text{mm}$ Ignore, except dense	$D \leq 0.2\text{mm}$ Ignore, except dense	$D \leq 0.3\text{mm}$ Ignore, except dense	$D \leq 0.3\text{mm}$ Ignore, except dense	accept
	$0.2 < D \leq 0.25, N \leq 2$	$0.2 < D \leq 0.5, N \leq 5$	$0.3 < D \leq 0.8, N \leq 5$	$0.3 < D \leq 0.8, N \leq 6$	accept
	$D > 0.25\text{mm}$	$D > 0.50\text{mm}$	$D > 0.80\text{mm}$	$D > 0.80\text{mm}$	reject
Side damage	$X \leq 0.5\text{ mm}$ $Y \leq 0.5\text{ mm}$ $Z \leq 1/2\text{ T}$ Unilateral: $N \leq 1$	$X \leq 0.5\text{ mm}$ $Y \leq 0.5\text{ mm}$ $Z \leq 1/2\text{ T}$ Unilateral: $N \leq 1$	$X \leq 0.5\text{ mm}$ $Y \leq 0.5\text{ mm}$ $Z \leq 1/2\text{ T}$ Unilateral: $N \leq 2$	$X \leq 0.5\text{ mm}$ $Y \leq 0.5\text{ mm}$ $Z \leq 1/2\text{ T}$ Unilateral: $N \leq 2$	accept
Angle damage	$X \leq 0.5\text{ mm}$ $Y \leq 0.5\text{ mm}$ $Z \leq 1/2\text{ T}$ , Unilateral: $N \leq 1$				accept
Glass crack	The crack is extended to the outer edge and is calculated according to the collapse; Progressive cracks extending to the inner edge are not allowed				

Sand edge	$W \leq 0.25\text{mm}$ , ignore; $W > 0.25\text{mm}$ , reject
Sawtooth	The width of the sawtooth near the VA area : $W \leq 0.3\text{mm}$ , allow, $W > 0.3\text{mm}$ , reject;
Main color ink light leak	Edge area leakage width : $W \leq 0.25\text{mm}$ Only unilateral leakage is allowed; Edge area leakage width $> 0.25\text{mm}$ reject
Screen printing	$W \leq 0.15\text{mm}$ , allow, $W > 0.15\text{mm}$ , reject
Main color ink pinhole	Outside the 2mm edge of the VA area, Reflection conditions check for invisible permission, Any pinholes are not allowed within 2mm of the area of the VA area
Defects in the main color ink layer	The ink layer has fiber, impurity reference visual area standard: Standards for scratch within the ink layer: $0.05\text{mm} < W \leq 0.08\text{mm}$ , $L \leq 3\text{mm}$ , $N \leq 1$ , allow; $W > 0.08\text{mm}$ , $L > 3\text{mm}$ , reject
Ink pattern spillage	$D \leq 0.15\text{mm}$ ; $N \leq 2$ , allow; $D > 0.15\text{mm}$ , reject
Ink pattern gap	Gap width $\leq 1/4h$ (h is the height of the pattern) or gap width $\leq 1/2w$ (w is the width of the pattern) allow
Dirty mark	Printing main color stain $W \leq 0.3\text{mm}$ ignore, Not visible under fluorescent lamps, allow; Printing main color stain $W > 0.3\text{mm}$ , visible under fluorescent lamps, reject
IR semi-permeable area ink pinhole	$D \leq 0.15\text{mm}$ , $N \leq 1$ , allow; $D > 0.15\text{mm}$ , reject;
IR semi-permeable area ink color difference	Reflector is not visible in black background, acceptable
IR semi-permeable area ink internal impurities	$D \leq 0.35\text{mm}$ ; $N \leq 5$ ,allow; $D > 0.35\text{mm}$ ; $N > 5$ , reject
Note: 1. 5 or more defects within 10mm are called intensive. (intensive defects: not allowed). The spacing of all defects is 10mm 2. inspection distance: $750 \pm 50\text{mm}$ , if appearance is invisible, ignore	

#### 12.6.2.5 . FPC defect

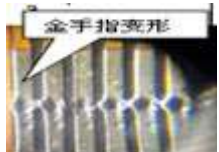
Defect	Description	Accepted standard	MAJ	MIN
FPC folding 	FPC is folding and can not restore-> Reject FPC is folding and can restore->compare with limited sample	Reject		√
FPC cover layer defect	FPC cover layer peeling off	Reject		√
FPC color shift and bubble	PI layer have color shift or bubbled due to high welding temperature or long welding time.	Reject		√
Golden finger defect 	peeling off、bonding deformed、glue remained、oxidized, stained	Reject		√

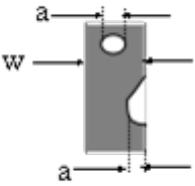
Joggle defect 	bent, broken, peeling off	Reject		√
FPC defect 	(golden finger) dented, pin hole $a \leq w/3$	Accept		√
	open/scratch/cracked/Gold finger has glue/FPC surface has glue accumulation	Reject		√
	oxidized, stained	Reject		√
FPC loophole	In the protected line area Or not affecting normal lines, The soft batch $\leq 2.5$ mm, accept, Hard board (PCB, PC, steel sheet reinforcing plate)The soft batch $\leq 1.0$ mm Or less than half of the edge of the wire to the edge (Take a smaller value)	Accept		√

#### 12.6.2.6. Attaching defect (protective film/adhesive tape/foam/PC...)

Defect	Description	Accepted standard	MAJ	MIN
High temperature glue paper	Glue paper attached in FPC doesn't cover component or FPC cover layer. 2.Glue paper attached in golden finger doesn't cover golden finger or peel off	Reject		√
Protective film	Clean, attaching flat, no shifting or bubble	Accept		√
	Protective film attaching bubble in VA: $D \leq 2.0$ mm $N \leq 5$ distance $\leq 20$ mm	Accept		√
	Protective film attaching bubble in VA: $D > 2.0$ mm $N > 5$ distance $> 20$ mm	Reject		√
Tape	Attach position refer to the drawing	Accept		√
Foam	1. Follow the drawings first 2. If the drawings are not specified in size, refer to the following requirements Gap spec: $0.5 \pm 0.5$ mm, foam must be smaller than sensor edge side and can not enter into VA.	Accept		√
PC board/adhesive tape	Tape must be smaller than LENS edge side and can not be folding, dent or shifting. Do not obstruct the hole;	Accept		√
Anti-explosion film/Anti-glare film/blue film/AG film	Impression print refer to the limited sample	Accept		√
	Attach position refer to the drawing	Accept		√
	The bubbles are not allowed in the OCA rubber layer, and the bubbles are ignored between the lens and the AG layer or the explosion-proof film layer	Accept		√

#### 12.6.2.7. Metal frame (Metal Bezel)

No.	Item	Description	Accepted criterion	MAJ	MIN
12.6.2.7.1	Material & surface treatment	Metal frame/surface treatment do not conform to the specifications.	Rejected	√	



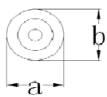
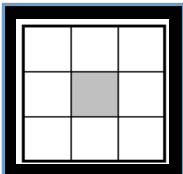

12.6.2.7.2	Tab twist Unconformity/ Tab not twisted	Wrong twist method or direction and twist tabs are not twisted as required.	Rejected	✓	
12.6.2.7.3	Bezel paint loss	Scratch/paint loss/Bezel surface concave-convex dot/dent	1.Front surface: Paint peel off and scratch to the bottom Dot: $D \leq 0.5\text{mm}$ , exceeds 3; Line: $L \leq 3.0\text{mm}$ , $W \leq$ $0.05\text{mm}$ exceeds 2; 2.Front dent, air bubble and side with paint peeling off scratch to the bottom Dot: $D \leq 1.0\text{mm}$ , exceeds 3; Line: $L \leq 3.0\text{mm}$ , $W \leq$ $0.05\text{mm}$ , exceeds 2;	✓	
12.6.2.7.4	Bezel scratch			✓	
12.6.2.7.5	Painting peel off, discoloration,dent, and scratch			✓	
12.6.2.7.6	Burr	Burr(s) on metal bezel is so long as to get into viewing area.	Rejected	✓	

#### 12.6.2.8. Others

Defect	Description	Accepted standard	MAJ	MIN
Glue flow 	Insulation oil flow in VA area	Reject		✓
	ACF/insulation oil flow in VA area	Reject		✓
	Sensor edge side glue flow	Accept		✓
IC/FPC gap glue	FPC gap glue:cover FPC connect point totally IC glue: cover IC line connect totally	Accept		✓
	Glue height : follow the technology spec	Accept		✓
Newton circles (rainbow) 	Circles quantity> 2	Reject		✓
Layering	LENS/Sensor layering	Reject	✓	
Surface	Stain defect which can be removed by cleaning solvent and cloth Defect quantity $\leq 10\%$ Lot total quantity->Accept Remark: defect product which is sorted out by AQL is not included in the 10% part.Unmovable stain refer to 6.1.1 specification.	Reject		✓
Isolation point  VA diagram	Gray area In 8X8mm area, all isolation points are missing	Reject		✓
	White area In 15X15mm area,all isolation points are missing	Reject		✓
	5mm within VA (black area) , isolation points missing ->Ignored	Accept		✓
	Isolation points are overlaid	Accept		✓

12.6.3 .Function inspection standard for TFT-LCM final goods

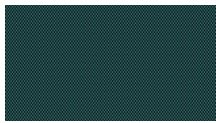
12.6.3.1 normal defect in TFT screen

Defects	Inspection Criterion	Pictures	Inspection method/tools	Defect category
No display /reaction	shows no picture/display in normal connected situation. ->Rejected		Naked eyes/ testers	MA
Missing segment	Shows missing lines in normal display		Naked eyes/ testers	MA
Flicker	Not accepted		Naked eyes/ testers	MA
Display abnormal	Not accepted		Naked eyes/ testers	MA
Display dim/bright	Refer to limited sample	/	Naked eyes/ limited sample	MA
Contrast	Refer to limited sample	/	Naked eyes/ limited sample	MA
White dot	Refer to dot criterion	/	Naked eyes	MI
White speckle	Refer to limited sample	/	Naked eyes/ limited sample	MI
Yellow speckle	Refer to limited sample	/	Naked eyes/ limited sample	MI

12.6.3.2 LCD pixel dot defect in TFT screen (defect category: MI)

Item	Inspection criterion			
	S <5"	5≤S<10"	10≤S<15"	>15"
Color pixel dot defect(RGB dot)	1	2	2	3
2 connected bright dot	0	0	1	1
3 connected bright dot or more	0	0	0	0
Bright dot quantity	1	2	3	4
Random dark dot quantity	2	3	4	5
2 connected dark dot	1	1	2	2
3 connected dark dot or more	0	0	0	0
Dark dot quantity	3	4	5	6
Multi-bright dot	ND 5% hidden, OK			
Remark: 2 bright dots distance $DS \geq 15\text{mm}$ 2 dark dots distance $DS \geq 5\text{mm}$ 1) Bright dot: Power on TFT and RGB dot in black display 2) Dark dot: Power on TFT and gray or black dot in RGB display 3) Multi-bright dot: Power on TFT and fluorescent tiny dot in black display(only visible in black display)				

12.6.3.3 Metal frame (Metal Bezel)



Item	Description	Accepted criterion	MAJ	MIN
Material & surface treatment	Metal frame/surface treatment do not conform to the specifications.	Rejected	√	
Tab twist Unconformity/ Tab not twisted	Wrong twist method or direction and twist tabs are not twisted as required.	Rejected	√	
Bezel paint loss	Scratch/paint loss/Bezel surface concave-convex dot/dent	1.Front surface: Paint peel off and scratch to the bottom Dot: $D \leq 0.5\text{mm}$ , exceeds 3; Line: $L \leq 3.0\text{mm}$ , $W \leq 0.05\text{mm}$ exceeds 2; 2.Front dent, air bubble and side with paint peeling off scratch to the bottom Dot: $D \leq 1.0\text{mm}$ , exceeds 3; Line: $L \leq 3.0\text{mm}$ , $W \leq 0.05\text{mm}$ , exceeds 2;	√	
Bezel scratch			√	
Painting peel off, discoloration, dent, and scratch			√	
Burr	Burr(s) on metal bezel is so long as to get into viewing area.	Rejected	√	

#### 12.6.3.3 Backlight components

Item	Description	Accepted criterion	MAJ	MIN
No backlight wrong Color	/	Rejected	√	
Color deviation	When powered on, the LCD color differs from its sample and found that the color not conforming to the drawing after testing.	Refer to sample and drawing.		√
Brightness deviation	When powered on, the LCD brightness differs from its sample and is found after testing not conforming to the drawing; or if it conforms to the drawing but the brightness over $\pm 40\%$ than its typical value.	Refer to sample and drawing.		√
Uneven brightness	Uneven on the same LCD and out of the specification of the drawing. The no specification evenness= (the max value-the min value)/ mean value < 70%.	Refer to sample and drawing.		√
Spot/line /scratch	When power on, it has dirty spot, scratches and so on spot and line defects.	Refer to dot/line standard		√

#### 12.6.3.4. Others

Item	Description	Accepted criterion	MAJ	MIN
Assembly foreign material	Dot/linear stain after assembly backlight and diffuse film TP assembly foggy stain	Invisible when power on->OK Refer to 6.1.1 dot/line spec		√
Product mark	Missing, unclear, incorrect, or misplaced part	Rejected		√
Newton' s rings	Area < 1/6 screen area quantity $\leq 1$	Accepted		√

Mura	In black display ND 5% invisible ->OK; visible->NG 2.Naked eyes inspection RGB display invisible Black display, area<1/4 screen area	Refer to limited sample 		√
Light leak	LCD edge (near backlight) shadow by LCD lamps irregular illuminate Judge in black/white/gray display (slight leaky is yellowish,greenish, blueish ->NG) ; 	Refer to limited sample		√
Polarizer	Polarizer slant.Cover VA and not over LCD edge 2.No unmovable stain or finger print in polarizer VA 3.Bubble/warped but not enter VA	Accepted		√

#### 12.6.4.General Appearance and Dimension(Major)

Common inspection equipment :micro calliper、 vernier caliper、 pencil hardness tester、 spectrophotometer 、 drop ball test and etc.

Items	Spec
Dimension	According to drawing
Curl	≤0.3% -> OK, " S" curl ->NG
Surface hardness	According to drawing
VA TT ( 550nm )	According to drawing
IR TT-- ( 550nm & 850nm )	According to drawing
Intensity ( drop ball test )	According to drawing

Remark: the criterion is common for all product and if some components are not included, just ignore it.

#### 12.7. Others

Items not specified in this document or released on compromise should be inspected with reference to mutual agreement and limit samples.

### 13. HANDLING PRECAUTIONS

#### 13.1 Mounting method

The LCD module consists of two thin glass plates with polarizes which easily be damaged. And since the module in so constructed as to be fixed by utilizing fitting holes in the printed circuit board.

Extreme care should be needed when handling the LCD modules.

#### 13.2 Caution of LCD handling and cleaning

When cleaning the display surface, Use soft cloth with solvent [recommended below] and wipe lightly :

- .Isopropyl alcohol
- .Ethyl alcohol

Do not wipe the display surface with dry or hard materials that will damage the polarizer surface.

Do not use the following solvent :

- .Water
- .Aromatics

Do not wipe ITO pad area with the dry or hard materials that will damage the ITO patterns

Do not use the following solvent on the pad or prevent it from being contaminated :

- .Soldering flux
- .Chlorine (Cl) , Sulfur (S)

If goods were sent without being silicon coated on the pad, ITO patterns could be damaged due to the



corrosion as time goes on.

If ITO corrosion happen by miss-handling or using some materials such as Chlorine (Cl), Sulfur (S) from customer, Responsibility is on customer.

### **13.3 Caution against static charge**

The LCD module use C-MOS LSI drivers, so we recommended that you :

Connect any unused input terminal to Vdd or Vss, do not input any signals before power is turned on, and ground your body, work/assembly areas, assembly equipment to protect against static electricity.

### **13.4 Packing**

Module employ LCD elements and must be treated as such.

- .Avoid intense shock and falls from a height.
- .To prevent modules from degradation, do not operate or store them exposed direct to sunshine or high temperature/humidity.

### **13.5 Caution for operation**

- .It is an indispensable condition to drive LCD's within the specified voltage limit since the higher voltage then the limit cause the shorter LCD life.
- .An electrochemical reaction due to direct current causes LCD's undesirable deterioration, so that the use of direct current drive should be avoided.
- .Response time will be extremely delayed at lower temperature then the operating temperature range and on the other hand at higher temperature LCD's how dark color in them. However those phenomena do not mean malfunction or out of order with LCD's, which will come back in the specified operation temperature.
- .If the display area is pushed hard during operation, some font will be abnormally displayed but it resumes normal condition after turning off once.
- .A slight dew depositing on terminals is a cause for electro-chemical reaction resulting in terminal open circuit.
- .Usage under the maximum operating temperature, 50%Rh or less is required.
- .When fixed patterns are displayed for a long time,remnant image is likely to occur.

### **13.6 Storage**

In the case of storing for a long period of time for instance, for years for the purpose or replacement use, the following ways are recommended.

- .Storing in an ambient temperature 10°C to 30°C, and in a relative humidity of 45% to 75%. Don't expose to sunlight or fluorescent light.
- .Storing in a polyethylene bag with the opening sealed so as not to enter fresh air outside in it . And with no desiccant.
- .Placing in a dark place where neither exposure to direct sunlight nor light's keeping the storage temperature range.
- .Storing with no touch on polarizer surface by the anything else.

It is recommended to store them as they have been contained in the inner container at the time of delivery from us.

### **13.7 Safety**

- .It is recommendable to crash damaged or unnecessary LCD's into pieces and wash off liquid crystal by either of solvents such as acetone and ethanol, which should be burned up later.
- .When any liquid leaked out of a damaged glass cell comes in contact with your hands, please wash it off well with soap and water.

## **14. PRECAUTION FOR USE**

**14.1** A limit sample should be provided by the both parties on an occasion when the both parties agreed its necessity. Judgment by a limit sample shall take effect after the limit sample has been established and confirmed by the both parties.

**14.2** On the following occasions, the handing of problem should be decided through discussion and agreement between responsible of the both parties.

- .When a question is arisen in this specification.
- .When a new problem is arisen which is not specified in this specifications.
- .When an inspection specifications change or operating condition change in customer is reported to ODNA, and some problem is arisen in this specification due to the change.
- .When a new problem is arisen at the customer's operating set for sample evaluation in the customer site.

## **15. PACKING SPECIFICATION**

Please consult our technical department for detail information.