

# AZ DISPLAYS, INC.

---

*COMPLETE LCD SOLUTIONS*

## SPECIFICATIONS FOR LIQUID CRYSTAL DISPLAY

[www.DataSheet4U.com](http://www.DataSheet4U.com)

PART NUMBER:

AG2412D Series

## General Specifications

Item	<input checked="" type="checkbox"/> Standard Value	Unit
Display Pattern	<input checked="" type="checkbox"/> Dot-Graphic <input type="checkbox"/> Character <input type="checkbox"/> Digits <input type="checkbox"/> with ICON	Dots
Color	<input checked="" type="checkbox"/> Mono. <input type="checkbox"/> Grayscale <input type="checkbox"/> _____	
Module Dimension	170.0(W)X93.0(H)X15.8(D)(Max)	mm
Viewing Area	129.0(W)X75.0(H)	mm
Active Area	119.97(W)X63.97(H)	mm
Character Size	/	mm
Character Pitch	/	mm
DOT Size	0.47(W)X0.47(H)	mm
DOT Pitch	0.50(W)X0.50(H)	mm
LCD Type	<input type="checkbox"/> TN, Positive <input type="checkbox"/> TN, Negative <input type="checkbox"/> HTN, Positive <input type="checkbox"/> HTN, Negative <input type="checkbox"/> STN, Yellow-Green <input type="checkbox"/> STN, Gray <input checked="" type="checkbox"/> STN, Blue <input type="checkbox"/> FSTN, Positive <input type="checkbox"/> FSTN, Negative <input type="checkbox"/> Color STN <input type="checkbox"/> FM LCD	
Polarizer Type	<input type="checkbox"/> Transflective <input checked="" type="checkbox"/> Transmissive <input type="checkbox"/> Reflective <input type="checkbox"/> Anti-Glare	
View Direction	<input type="checkbox"/> 6H <input checked="" type="checkbox"/> 12H <input type="checkbox"/> _____	
LCD Controller & Driver	T6963C OR EUQIVALENT	
LCD Driving Method	1/128duty, 1/12bias	
Interface Type	<input type="checkbox"/> I <sup>2</sup> C <input type="checkbox"/> 4-wire Serial <input type="checkbox"/> 3-wire Serial <input type="checkbox"/> 6800 <input checked="" type="checkbox"/> 8080 <input type="checkbox"/> 4-bit <input type="checkbox"/> _____	
Backlight Type	<input checked="" type="checkbox"/> LED <input type="checkbox"/> Bottom <input checked="" type="checkbox"/> Single Side <input type="checkbox"/> Dual Side <input type="checkbox"/> EL <input type="checkbox"/> CCFL <input type="checkbox"/> _____	
Backlight Color	<input type="checkbox"/> Yellow-Green <input checked="" type="checkbox"/> White <input type="checkbox"/> Amber <input type="checkbox"/> Blue <input type="checkbox"/> Red <input type="checkbox"/> _____	
EL/CCFL Driver type	/	
DC-DC Converter	<input type="checkbox"/> Build-in <input checked="" type="checkbox"/> External	
Operation Temperature	-20 ~ 60	°C
Storage Temperature	-30 ~ 70	°C

## Electrical-optical Specifications

### Absolute Maximum Ratings

Item	Symbol	Condition	Min.	Typ.	Max.	Unit
Supply Voltage For Logic	$V_{DD} - V_{SS}$	$T_a=25^{\circ}\text{C}$	-0.3	-	7.0	V
Supply Voltage	$V_{EE}$	$T_a=25^{\circ}\text{C}$	$V_{DD} - 30$	-	$V_{DD} + 0.3$	V
Supply Voltage For Lcd Driver	$V_{LCD}$	$T_a=25^{\circ}\text{C}$	$V_{EE} - 0.3$	-	$V_{DD} + 0.3$	V
Input Voltage	$V_I$	$T_a=25^{\circ}\text{C}$	-0.3	-	$V_{DD} + 0.3$	V
Operating temperature	$T_o$	-	-20	-	60	$^{\circ}\text{C}$
Storage temperature	$T_s$	-	-30	-	70	$^{\circ}\text{C}$

Note: Operating Temperature and Storage Temperature can be found in 1.General Specifications.

### Electrical-optical Characteristics

No.	Item	Symbol	Condition	Min.	Typ.	Max.	Unit	
1	Contrast Ratio	Cr	$T_a=25^{\circ}\text{C}$ $V_{LCD} = 12.7\text{V}$	3.0	3.4		-	
2	Threshold voltage	$V_{th}$	$T_a=25^{\circ}\text{C}$	1.88	1.904		V	
3	Saturation voltage	$V_{sat}$	$T_a=25^{\circ}\text{C}$		2.044	2.07	V	
4 5	Response time	Rise time	$T_a=25^{\circ}\text{C}$		148	200	ms	
		Fall time	$T_a=25^{\circ}\text{C}$		209	250	ms	
		On time	$T_{ON}$	$T_a=25^{\circ}\text{C}$		172	230	ms
		Off time	$T_{OFF}$	$T_a=25^{\circ}\text{C}$		240	280	ms
6	Viewing Angle	6H	1	$Cr = 2$ $T_a=25^{\circ}\text{C}$		30	Deg	
7		12H	2			50	Deg	
8		3H	3			50	Deg	
9		9H	4			50	Deg	
10	Frame frequency	FR	/	50	70	85	Hz	
11	Clock Oscillation Frequency	fosc	/	/	6.0	/	Mhz	

#### LED back light Electrical/Optical characteristics

$T_a=25^{\circ}\text{C}$

ITEM	SYMBOL	CONDITION	MIN.	TYP E	MAX.	UNIT
Forward current	$I_f$	$V_f=4.2\text{ V}$ White	60	90	200	mA

Luminous Intensity	Iv	Vf=4.2 V White	120	180	/	Cd/m <sup>2</sup>
Luminous Tolerance	/	/	/	/	20	%
Chromaticity coordinate	X	Vf=4.2 V White	0.287	0.31	0.330	/
Chromaticity coordinate	Y	Vf=4.2 V White	0.276	0.32	0.339	/

Note:

### 6.3 Electrical Characteristics

No	Item	Symbol	Condition	Min.	Typ.	Max.	Unit
1	Supply Voltage for Logic	$V_{DD}-V_{S_s}$	-	4.5	5.0	5.5	V
2	Supply Voltage for LCD Driver	$V_{DD}-V_{O_s}$ ( $V_{LCD}$ )	$T_a=25\pm 3^\circ\text{C}$	16.9	17.2	17.5	V
3	Supply Current for Logic	$I_{DD}$	$T_a=25\pm 3^\circ\text{C}$ $V_{DD}=5.0\text{V}$	-	11.0	24.0	mA
4	Input High Voltage	$V_{IH}$	-	$V_{DD}-\frac{2}{2}$	/	$V_{DD}$	V
5	Input Low Voltage	$V_{IL}$	-	0	/	0.8	V
6	Output High Voltage	$V_{OH}$	-	$V_{DD}-0.3$	-	$V_{DD}$	V
7	Output Low Voltage	$V_{OL}$	-	$V_{SS}$	-	0.3	V

### 6.4 Timing Characteristics

#### (1) System Bus Read/Write Characteristics

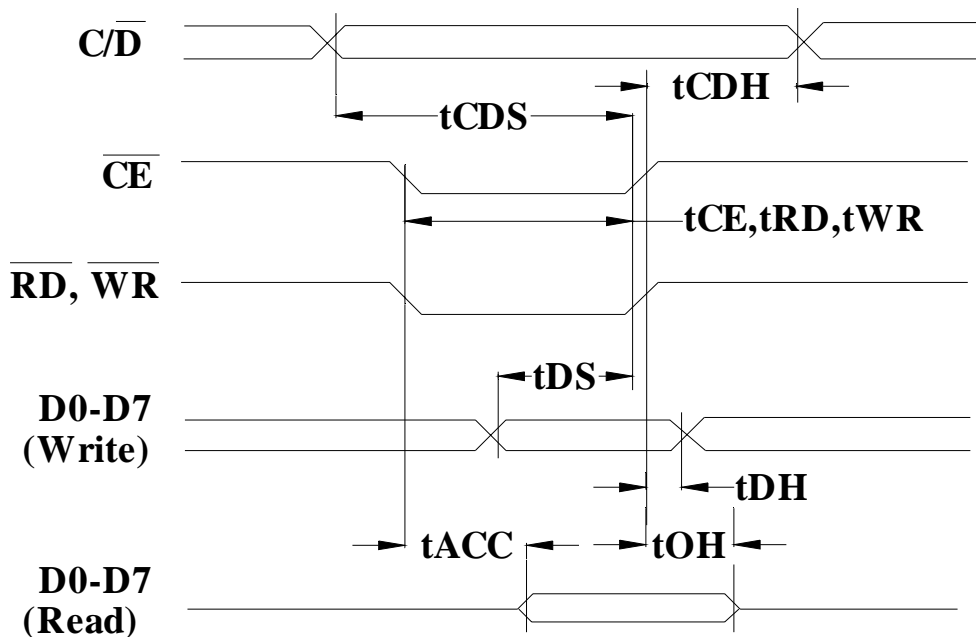

( $V_{DD} = 4.5\text{ V to }5.5\text{ V}$ ,  $T_a = -10\text{ to }70^\circ\text{C}$ )

Item	Symbol	Condition	Rating		Units
			Min	Max	
C/D Set Up Tme	tCDS		100	—	ns
C/D Hold Time	tCDH		10	—	ns
CE,RD, WR Pulse Width	tce, trd, tWR		80	—	ns
Data Set Up Time	tDS		80	—	ns ns
Data Hold Time	tDH		40	—	ns
Access Time	tACC		—	150	
Output Hold Time	tOH		10	50	ns

## Instruction Description

### Table of T6963C Commands

Command	CODE	D1	D2	Function
(1) REGISTER SET	00100001 00100010 00100100	X address Data Low address	Y address 00H High address	Cursor pointer set Offset register set Address pointer set
(2) CONTROL WORD SET	01000000 01000001 01000010 01000011	Low address Columns Low address Columns	High address 00H High address 00H	Text home address set Text area set Graphic home address set Graphic area set
(3) MODE SET	1000X000 1000X001 1000X011 1000X100 10000XXX 10001XXX	- - - - - -	- - - - - -	"OR" mode "EXOR" mode "AND" mode "Text attribute" mode Internal CG ROM mode External CG ROM mode
(4) DISPLAY MODE	10010000 1001XX10 1001XX11 100101XX 100110XX 100111XX	- - - - - -	- - - - - -	Display Off Cursor on, blink off Cursor on, blink on Text on, graphic off Text off, graphic on Text on, graphic on
(1) CURSOR PATTERN SELECT	10100000 10100001 10100010 10100011 10100100 10100101 10100110 10100111	- - - - - - - -	- - - - - - - -	1 line cursor 2 lines cursor 3 lines cursor 4 lines cursor 5 lines cursor 6 lines cursor 7 lines cursor 8 lines cursor
(2) DATA AUTO READ/WRITE	10110000 10110001 10110010	- - -	- - -	Data auto write set Data auto read set Auto reset
(7) DATA READ WRITE	11000000 11000001 11000010 11000011 11000100 11000101	Data - Data - Data -	- - - - - -	Data write and ADP increment Data read and ADP increment Data write and ADP decrement Data read and ADP decrement Data write and ADP non variable Data read and ADP non variable
(8) SCEEN PEEK	11100000	-	-	Screen peek
(9) SCEEN COPY	11101000			Screen copy
(10) BIT SET/RESET	11110XXX 11111XXX 1111X000 1111X001 1111X010	- - - - -	- - - - -	Bit reset Bit set Bit 0 (LSB) Bit 1 Bit 2



## Interface Description

Pin No.	Symbol	Level	Function Description
1	FG	/	FRAME GROUND
2	Vss	/	GROUND (0V)
3	Vdd	+5.0 V	Power supply for logic (+)
4	Vee	-12.2 V	LCD Drive Voltage (-)
5	/WR	H/L	Write Signal
6	/RD	H/L	Read Signal
7	/CE	H/L	Chip Enable
8	C/D	H/L	Command/Data
9	NC	/	No connected
10	/RST	H/L	Reset
11	DB0	H/L	Data Input/Output(LSB)
12	DB1	H/L	Data Input/Output
13	DB2	H/L	Data Input/Output
14	DB3	H/L	Data Input/Output
15	DB4	H/L	Data Input/Output
16	DB5	H/L	Data Input/Output
17	DB6	H/L	Data Input/Output
18	DB7	H/L	Data Input/Output(MSB)
19	FS	H/L	H:6X8 Character Font L:8X8 Character Font
20	RV	/	Reverse data in

# Block Diagram

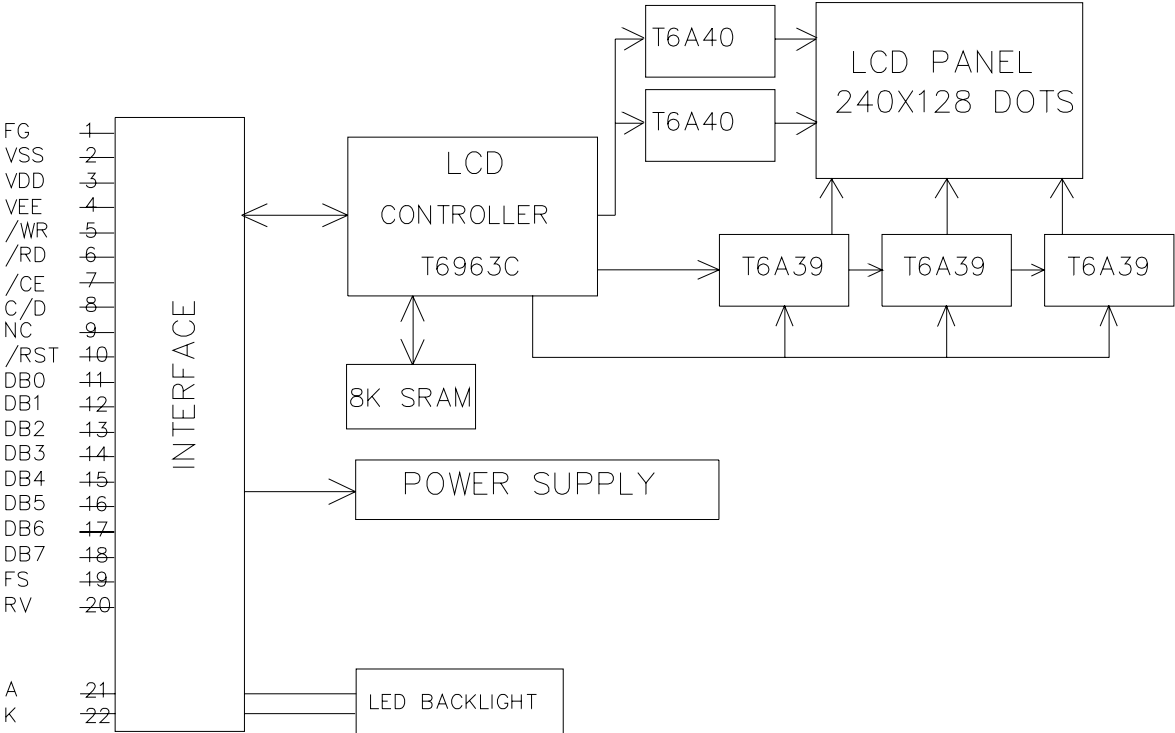



A to C ut

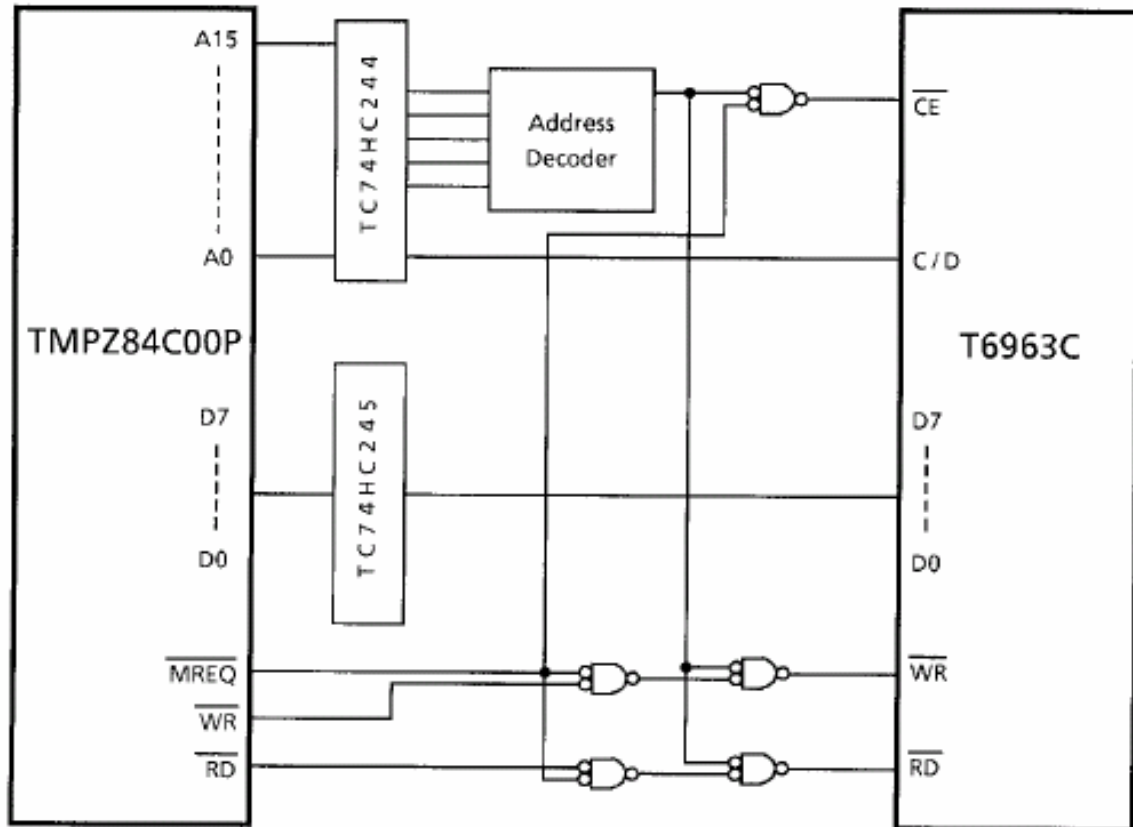

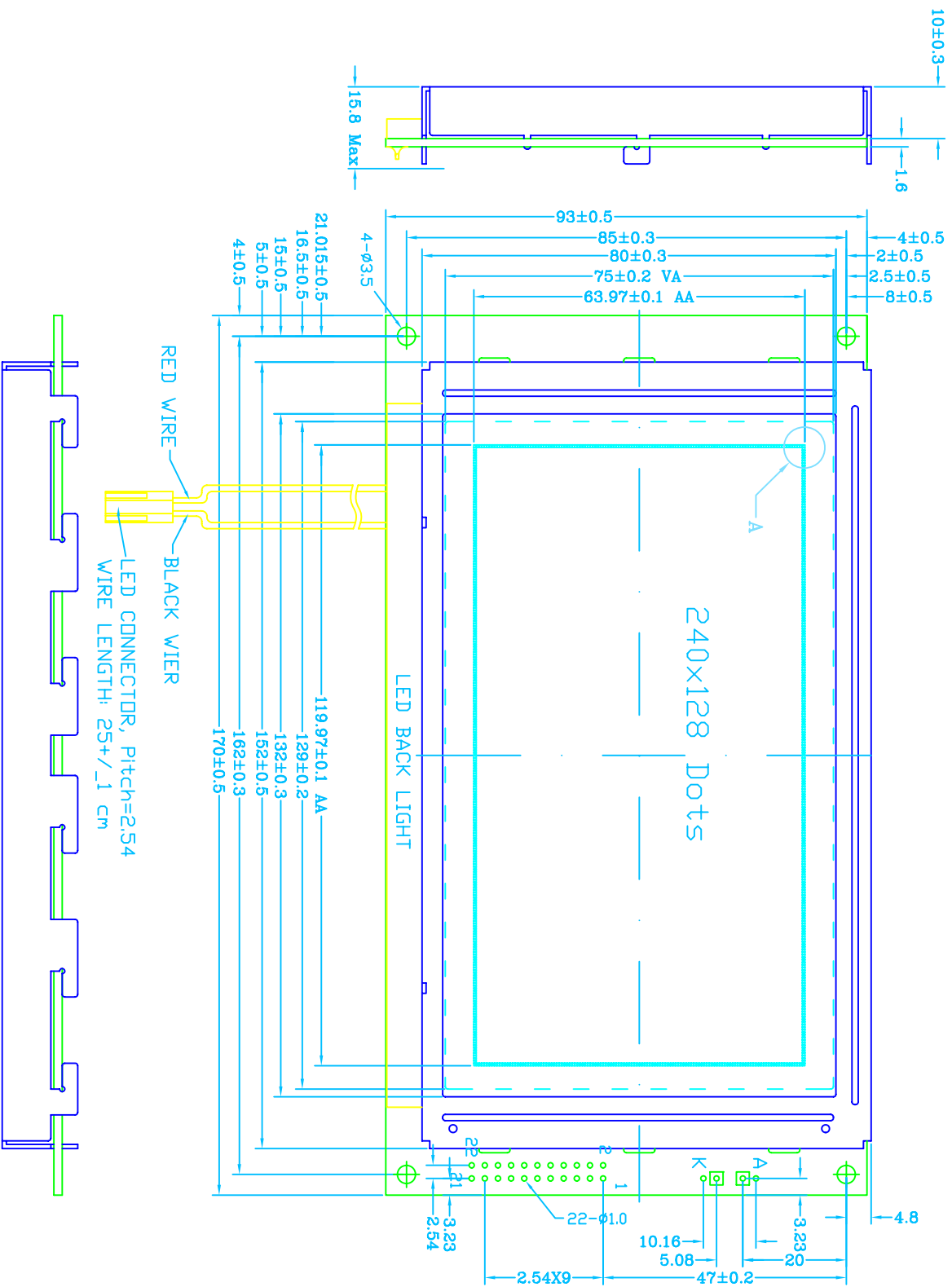

PIN	NAME
1	FG
2	VSS
3	VDD
4	Vee
5	WR
6	RD
7	CE
8	C/D
9	NC
10	RES
11	DB0
12	DB1
13	DB2
14	DB3
15	DB4
16	DB5
17	DB6
18	DB7
19	FS
20	RV
21	A
22	K

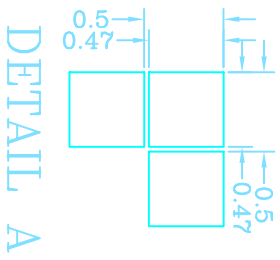

- NOTE:
- 1.DISPLAY TYPE: FSTN/STN,Transflective/ Transmissive,Positive
  - 2.VIEWING DIRECTION: 12:00
  - 3.DRIVER IC: T6963C
  - 4.LOGIC VOLTAGE: 5.0±0.1V
  - 5.LCD DRIVE VOLTAGE(Vlcd): 17.2±0.1V
  - 6.DRIVING METHOD: 1/128 DUTY, 1/12 BIAS

- 7.BACKLIGHT: White LED Backlight
- 8.OPERATING TEMPRATURE: -20° ~ +70° C
- 9.STORAGE TEMPRATURE: -40° ~ +80° C
- 10.INTERFACE CONNECTOR: PIN
- 11.ALL UNMARKED TOLERANCE: ±0.2mm