



ALGOLTEK

AG9320

**Type-C to HDMI/VGA
Converter**

Data Sheet

Official Version

V1.3

October, 2017



Revision History

Version	Date	Notes
1.0.0	2017/9/15	First release
1.1.0	2017/10/24	Template modification
1.1.1	2018/06/13	Added GPIO supported
1.2	2019/01/23	Revised VGA Resolution
1.3	2019/4/29	Update Table3: Add $T_j / \theta_{JC} / \theta_{JA}$

Copyright

Copyright©2017 Algotek, Inc. All rights reserved. The contents of these materials contain proprietary and confidential information (including trade secrets, copyright, and other Intellectual Property interests) of Algotek, Inc. or its affiliates. All rights are reserved and contents, (in whole or in part) may not be reproduced, downloaded, disseminated, published, or transferred in any form or by any means, except with the prior written permission of Algotek, Inc. or its affiliates.



Index

I.	General Description	5
II.	Features	5
III.	Device Information	6
IV.	Application	6
V.	System Block Diagram.....	7
VI.	Pin Mapping and Description.....	8
VII.	Specification.....	12
i.	Absolute Maximum Rating.....	12
ii.	DC Characteristics/Operating Conditions	12
iii.	AC Characteristics	13
VIII.	Packing and Marking Specification	16
IX.	References.....	187
X.	Contact Information.....	187



List of Figure

Figure 1 Application for Type to HDMI/VGA Dongle.....	6
Figure 2 System Block Diagram	7
Figure 3 AG9320 PIN Mapping	8
Figure 4 AG9320 Package Dimension	17

List of Table

Table 1 PIN Description	11
Table 2 Absolute Maximum Rating.....	12
Table 3 Digital I/O Specification.....	12
Table 4 DisplayPort Input Timing	13
Table 5 DisplayPort AUX Channel I/O Specification	14
Table 6 USB I/O Specification.....	15
Table 7 USB PD Specification	15



I. General Description

ALGOLTEK AG9320 is a single chip solution to implement Type-C to HDMI/VGA data converter. AG9320 is a single chip solution which transmits both the video and audio streams via single USB Type-C connector. Its DisplayPort 1.2 receiver supports configurable 1, 2 and 4 lanes @ 1.62Gbps, 2.7Gbps and 5.4Gbps input, and the HDMI supports up to 4K2K@30Hz output. Otherwise, the RGB triple-DAC supports up to 1200P@60Hz output. AG9320 Series also support the external SPI flash for the firmware upgrade for better compatibility and flexibility. It's a good fit for the applications of docking stations, extended display adaptors and dongles for the laptop PC, tablet and smartphone accessory markets.

II. Features

- Embedded 16 bit MCU
- EDID and MCCS pass-through supported
- Supports Hot Plug Detection
- External SPI flash supported for firmware upgrade
- Embedded HDCP 1.4 supported
- HDMI 1.4b TX supports 4K@30Hz output
- VGA supports 1920x1200p@60Hz output
- Simultaneously display via HDMI and VGA outputs
- 2KV ESD performance
- Down Spread Spectrum Clock (SSC) supported



III. Device Information www.angerei.com 400-880-5552 18520874087 QQ: 1659747718

Part Number	Package	Body Size	Note
AG9320	QFN-88	10x10 mm ²	/w I ² S audio output

IV. Application

- USB Type-C dongle
- USB Type-C docking station
- TV/Projector Type-C interface

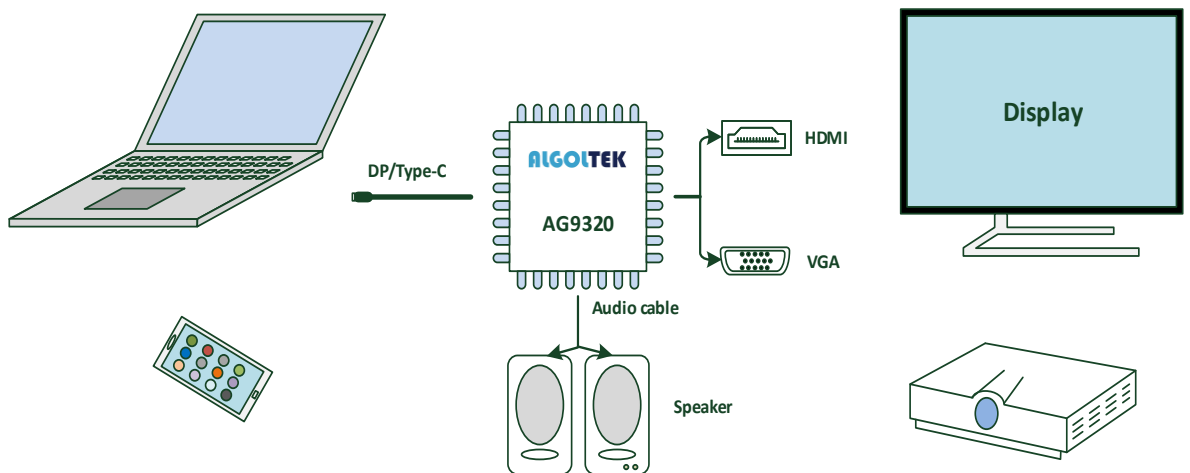

Figure 1 Application for Type-C to HDMI/VGA Dongle



V. System Block Diagram

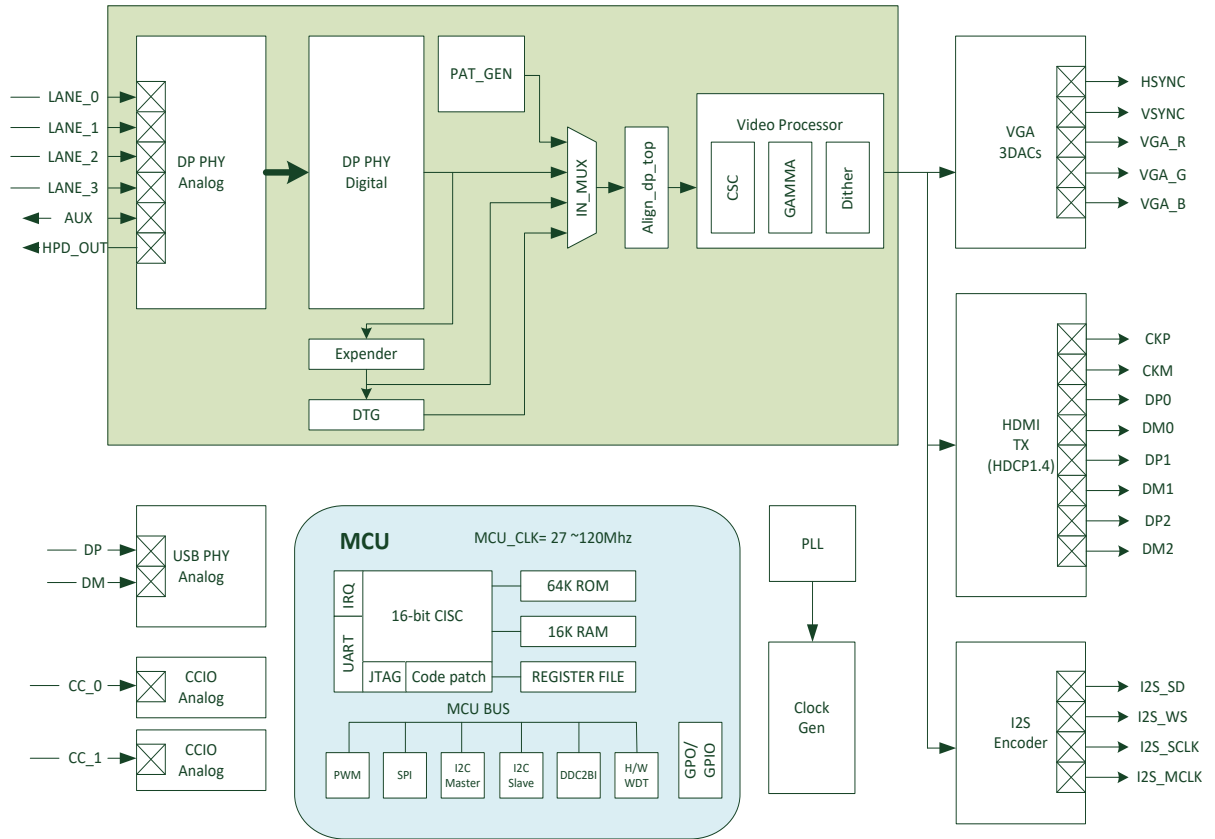

Figure 2 System Block Diagram



VI. Pin Mapping and Description

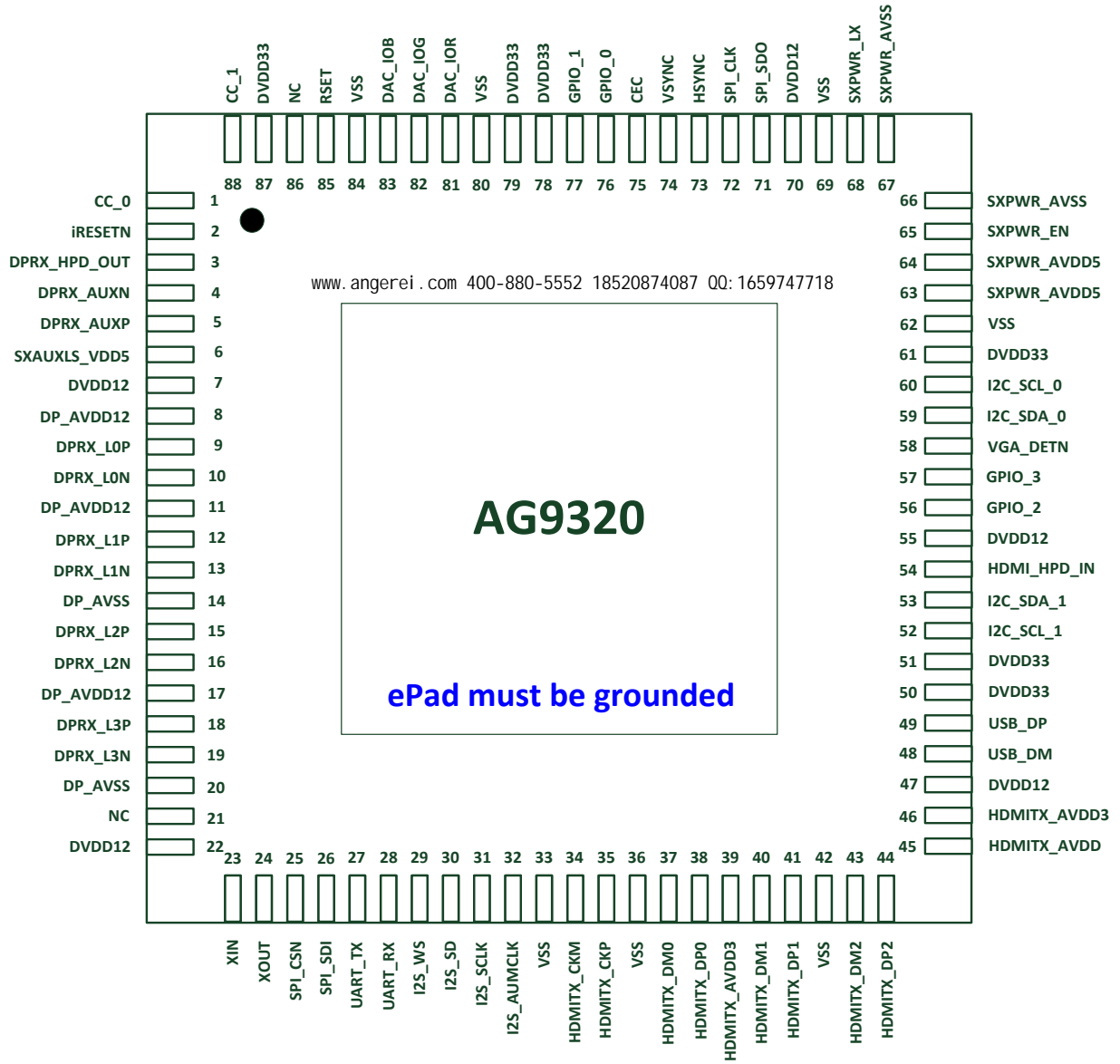

Figure 3 AG9320 PIN Mapping



Pin Name	PIN NO.	Type	Description
POWER SUPPLY			
SXAUXLS_VDD5	6	Power	Analog 5V power input for AUX channel
DP_AVDD12	8, 11, 17	Power	Analog 1.2V power input for DP RX
DP_AVSS	14, 20	Power	Analog ground for DP RX
DVDD33	50, 51, 61 78, 79, 87	Power	Digital 3.3V I/O power input
DVDD12	7, 22, 47, 55, 70	Power	Digital 1.2V core power input
VSS	33, 36, 42, 62, 69, 80, 84	Power	Digital ground
HDMITX_AVDD	45	Power	Analog 1.2V power for HDMI TX
HDMITX_AVDD3	39, 46	Power	Analog 3.3V power for HDMI TX
SXPWR_AVDD5	63, 64	Power	5.0V power input. Input voltage range: 3.0V ~ 5.5V
SXPWR_AVSS	66, 67	Power	Analog ground.
SXPWR_LX	68	Power	NC
DIFFERENTIAL HIGH-SPEED IO <small>www.angerei.com 400-880-5552 18520874087 QQ:1659747718</small>			
DPRX_LOP	9	Input	DP RX lane0 positive
DPRX_LON	10	Input	DP RX lane0 negative
DPRX_L1P	12	Input	DP RX lane1 positive
DPRX_L1N	13	Input	DP RX lane1 negative
DPRX_L2P	15	Input	DP RX lane2 positive
DPRX_L2N	16	Input	DP RX lane2 negative
DPRX_L3P	18	Input	DP RX lane3 positive
DPRX_L3N	19	Input	DP RX lane3 negative
HDMITX_CKM	34	Output	HDMI TX clock channel negative
HDMITX_CKP	35	Output	HDMI TX clock channel positive
HDMITX_DM0	37	Output	HDMI TX data channel 0 negative
HDMITX_DP0	38	Output	HDMI TX data channel 0 positive
HDMITX_DM1	40	Output	HDMI TX data channel 1 negative
HDMITX_DP1	41	Output	HDMI TX data channel 1 positive



HDMITX_DM2	43	Output	HDMI TX data channel 2 negative
HDMITX_DP2	44	Output	HDMI TX data channel 2 positive
USB_DM	48	Bidirectional	USB Type-C D-
USB_DP	49	Bidirectional	USB Type-C D+
DPRX_AUXN	4	Bidirectional	DisplayPort AUX channel N
DPRX_AUXP	5	Bidirectional	DisplayPort AUX channel P
Digital IO			
www.angerei.com 400-880-5552 18520874087 QQ:1659747718			
CC_0	1	Input	Type-C configuration channel
iRESETN	2	Input	H/W Reset signal, active low. Need connect to Resistor and Capacitor on board.
DPRX_HPD_OUT	3	Output	DP RX Hot Plug Detect
XIN	23	Input	Crystal oscillator clock input
XOUT	24	Output	Crystal oscillator clock output
SPI_CSN	25	Output	SPI chip select.
SPI_SDI	26	Input	SPI data input
UART_TX	27	Output	UART TX
UART_RX	28	Input	UART RX
I2S_WS	29	Output	I2S Left Right Clock
I2S_SD	30	Output	I2S Serial Audio Data Output
I2S_SCLK	31	Output	I2S Continuous Serial Clock
I2S_AUMCLK	32	Output	I2S System Clock
I2C_SCL_1	52	Bidirectional	HDMI I2C SCL
I2C_SDA_1	53	Bidirectional	HDMI I2C SDA
HDMI_HPD_IN	54	Input	HDMI cable detection
GPIO_2	56	Bidirectional	General Purpose I/O
GPIO_3	57	Bidirectional	General Purpose I/O
VGA_DET_N	58	Input	VGA cable detection
I2C_SDA_0	59	Bidirectional	VGA I2C SDA
I2C_SCL_0	60	Bidirectional	VGA I2C SCL
SXPWR_EN	65	Input	Pull down to ground
SPI_SDO	71	Output	SPI data output.
SPI_CLK	72	Output	SPI clock.
HSYNC	73	Output	Horizontal sync signal to monitor
VSYNC	74	Output	Vertical sync signal to monitor



CEC	75	Input	HDMI CEC
GPIO_0	76	Bidirectional	General Purpose I/O
GPIO_1	77	Bidirectional	General Purpose I/O
CC_1	88	Input	Type-C configuration channel
Analog IO			
DAC_IOR	81	Output	VGA red channel output Pull down to ground by an 75Ω resistor
DAC_IOG	82	Output	VGA green channel output Pull down to ground by an 75Ω resistor
DAC_IOB	83	Output	VGA blue channel output Pull down to ground by an 75Ω resistor
RSET	85	Input	VGA full-scale current control resistor Pull down to ground by an 4.7KΩ resistor

Table 1 PIN Description



VII. Specification

i. Absolute Maximum Rating

www.angerei.com 400-880-5552 18520874087 QQ:1659747718

Symbol	Parameter	Min	Max	Unit
VDD5	5V Power Input	-0.5	5.5	V
VDD33/AVDD33	3.3V supply voltage	-0.5	3.63	V
VDD/AVDD	1.2V supply voltage	-0.5	1.32	V

Table 2 Absolute Maximum Rating

ii. DC Characteristics/Operating Conditions

www.angerei.com 400-880-5552 18520874087 QQ:1659747718

Symbol	Parameter	Min	Typ.	Max	Unit
VDD5	5V Power Input	4.5	5	5.5	V
VDD33	Digital I/O supply voltage	3	3.3	3.6	V
VDD	Digital core supply voltage	1.16	1.2		V
AVDD3	Analog I/O supply voltage	3	3.3	3.6	V
AVDD	Analog core supply voltage	1.16	1.2		V
I _{VDD33+AVDD3}	3.3V I/O Supply Current (4K2K/30Hz)		80		mA
I _{VDD+AVDD}	1.2V Core supply Current (4K2K/30Hz)		380		mA
V _{OH}	Output High Voltage	2.4			V
V _{OL}	Output Low Voltage			0.4	V
V _{IH}	Input High Voltage	2.0		5.5	V
V _{IL}	Input Low Voltage	-0.3		0.8	V
I _{LI}	Input leakage Cur.			±1	uA
θ _{JC}	Thermal Resistance(Junction to Case)		0.8		°C/W
θ _{JA}	Thermal Resistance (Junction to Ambient)		19		°C/W
T _J	Junction Temperature	0		125	°C
T _A	Ambient Temperature	0		70	°C

Table 3 Digital I/O Specification



iii. AC Characteristics www.angerei.com 400-880-5552 18520874087 QQ: 1659747718

DisplayPort Main Link AC Characteristics

Symbol	Parameter	Min	Typ.	Max	Unit
UI_HBR2	Unit interval for HBR2(5.4-Gbps/lane)		185		ps
UI_HBR	Unit interval for HBR(2.7-Gbps/lane)		370		ps
UI_RBR	Unit interval for RBR(1.62-Gbps/lane)		617		ps
Down_Spread_Amp.	Link clock down-spreading	0		0.5	%
Down_Spread_Frequency	Link clock down-spreading frequency	30		33	kHz
T _{RX-MEDIAN-to-MAX-JITTER}	Max time between the jitter median and max. deviation from the median at Rx package pins for HBR (2.7-Gbps)			0.265	UI
T _{RX-MEDIAN-to-MAX-JITTER}	Max. time between the jitter median and max. deviation from the median at Rx package pins for RBR (1.62-Gbps)			0.39	UI
V _{RX-DC-CM}	RX DC Common Mode Voltage	0		2	V
I _{RX-SHORT}	RX Short Circuit Current Limit			50	mA

Table 4 DisplayPort Input Timing

**DisplayPort AUX-CH AC Characteristics** TEL18520874087 QQ: 1659747718

Symbol	Parameter	Min	Typ.	Max	Unit
UIMAN	AUX (Manchester transaction) unit interval	0.4	0.5	0.6	us
Pre-charge Pulses	Number of pre-charge pulses	10		16	
T _{AUX-BUS-PEAK}	AUX CH bus park time	10			ns
T _{cycle-to-cycle jitter}	Maximum allowable variation for adjacent bit times within a single transaction at connector pins of a receiving device			0.05	UI
V _{AUX-DIFFp-p RX}	AUX peak-to-peak voltage at a transmitting device when receiving	0.29		1.38	V
V _{AUX-DIFFp-p RX}	AUX peak-to-peak voltage at a receiving device when receiving	0.27		1.36	V
V _{AUX_TERM_R}	AUX CH termination DC resistance		100		Ω
V _{AUX_DC_CM}	AUX DC common mode voltage	0		2.0	V
V _{AUX_TURN_CM}	AUX turn around common mode voltage			0.3	V
I _{AUX_SHORT}	AUX short circuit current			90	mA
C _{AUX}	AUX AC coupling	75		200	nF

Table 5 DisplayPort AUX Channel I/O Specification

**USB PD BMC Receiver Normative Requirements** TEL18520874087 QQ: 1659747718

Name	Description	Min	Typ.	Max	Unit
cReceiver	CC receiver capacitance	200		600	pF
nTransitionCount	Transitions for signal detect	3			
tRxFilter	Rx bandwidth limiting filter (digital or analog)	100			ns
tTransitionWindow	Time window for detecting non-idle	12		20	Us
zBmcRx	Receiver Input Impedance	1			MΩ
vNoiseActive	Noise amplitude when BMC is active.			165	mV
vNoiseIdle	Noise amplitude when BMC is idle.			300	mV
vIRDropGNDC	Cable Ground IR Drop			250	mV

Table 6 USB I/O Specification

USB PD BMC Transmitter Normative Requirements TEL18520874087 QQ: 1659747718

Name	Description	Min	Typ.	Max	Unit
tEndDriveBMC	Time to cease driving the line after the end of the last bit of the Frame.			23	us
tFall	Fall Time	300			ns
tHoldLowBMC	Time to cease driving the line after the final high-to-low transition.	1			us
tRise	Rise time	300			ns
vSwing	Voltage Swing	1.05	1.12 5	1.2	V
zDriver	Transmitter output impedance	33		75	Ω

Table 7 USB PD Specification



VIII. Packing and Marking Specification

- Marking

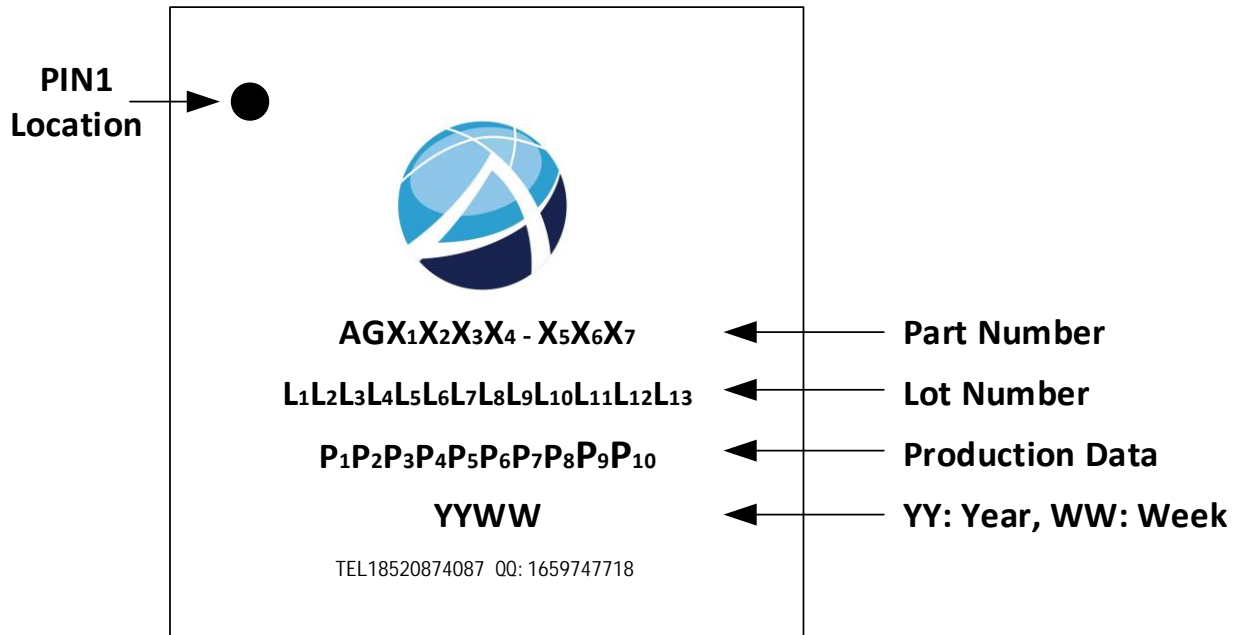



AG9320
Type-C to HDMI/VGA converter

● Package Dimension
AG9320: QFN-88L 10x10mm

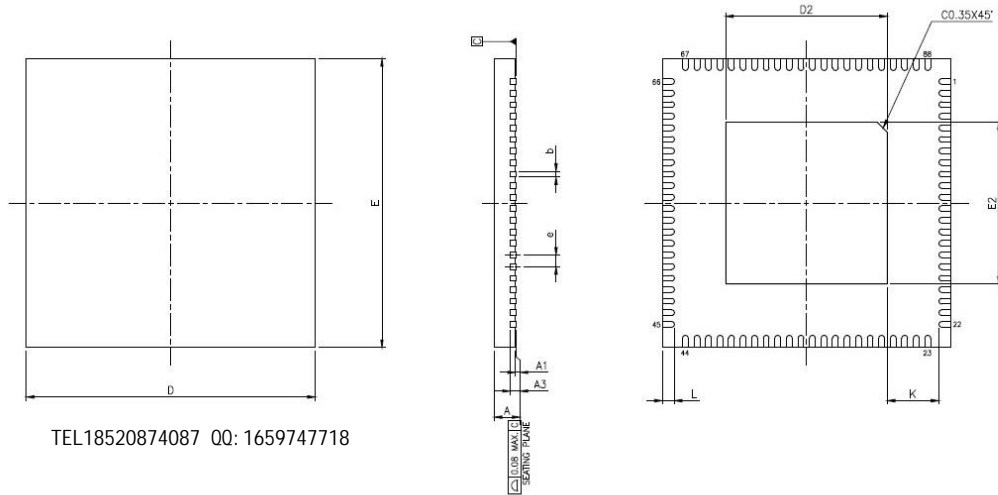

TEL18520874087 QQ: 1659747718

JEDEC OUTLINE	MO-220		
PKG CODE	WQFN(XA88)		
SYMBOLS	MIN.	NOM.	
A	0.70	0.75	0.80
A1	0.00	0.02	0.05
A3	0.203 REF.		
D	10.00 BSC		
E	10.00 BSC		
e	0.40 BSC		
L	0.35	0.40	0.45
K	0.20	—	—

NOTES :

1. ALL DIMENSIONS ARE IN MILLIMETERS.
2. DIMENSION b APPLIES TO METALLIZED TERMINAL AND IS MEASURED BETWEEN 0.15mm AND 0.30mm FROM THE TERMINAL TIP. IF THE TERMINAL HAS THE OPTIONAL RADIUS ON THE OTHER END OF THE TERMINAL, THE DIMENSION b SHOULD NOT BE MEASURED IN THAT RADIUS AREA.
3. BILATERAL COPLANARITY ZONE APPLIES TO THE EXPOSED HEAT SINK SLUG AS WELL AS THE TERMINALS.

PAD SIZE	D2			E2			b			LEAD FINISH		JEDEC CODE
	MIN.	NOM.	MAX.	MIN.	NOM.	MAX.	MIN.	NOM.	MAX.	Pure Tin	PPF	
276X27* MIL	6.75	6.80	6.85	6.75	6.80	6.85	0.15	0.20	0.25	V	X	(W)VNNE-1

Figure 4 AG9320 Package Dimension



IX. References

- DisplayPort™ Standard 1.2b Specification
- HDMI 1.4b Specification

X. Contact Information

ALGOLTEK, INC.
www.algotek.com.tw
Sales@algotek.com.tw

Copyright Notice

Copyright 2014 – 2024
Algotek, Inc.
All Right Reserved.

Trademark Acknowledgements

The company and product names mentioned in this document may be the trademarks or registered trademarks of their manufactures.

Disclaimer

Algotek, Inc. reserves the right to change this product without prior notice. Algotek, Inc. makes no warranty for the use of its products and bears no responsibility for any error that appear in this document. Specifications are subject to change without prior notice.