



Rectifier Type AH213

General. The AH213 is a hot-cathode mercury-vapour rectifier which incorporates a domed anode and a shrouded cathode in a hard glass bulb. It is suitable for the supply of rectified currents up to 10 A at 15 kV depending upon the circuit employed.

The valve should be operated with an air blast but care should be taken to ensure that the anode portion of the valve is not cooled, as this type of rectifier should be operated with the top of the bulb hot.

The filament may be switched on in one operation.

The conditioning schedule, to be followed after transit or storage, is one hour at normal filament voltage with neither anode voltage nor air blast applied to the valve.

The valve must always be shielded from draughts, though air circulation around the valve must not be impeded.

Conditions of Operation

(a) Continuous Air Blast at Constant Temperature.

With this arrangement an air blower is operating continuously and a thermostatically controlled air heater is used to maintain a constant temperature. The optimum air blast temperature is between 35° and 40°C.

It is imperative that a tube be fitted round the lower half of the valve.

(b) Thermostatically Controlled Forced Air Blast at Ambient Air Temperature.

As an alternative to the above arrangement, the air blast may be switched on and off by a thermostat, which operates at the ambient air temperature measured at a point on a level with the base of the valve and 6 in. away from it.

The blower must be switched off between 5°C and 22°C and must be on between 22°C and 40°C. The valve must never be operated when the ambient temperature is below 3°C. When operating under these conditions

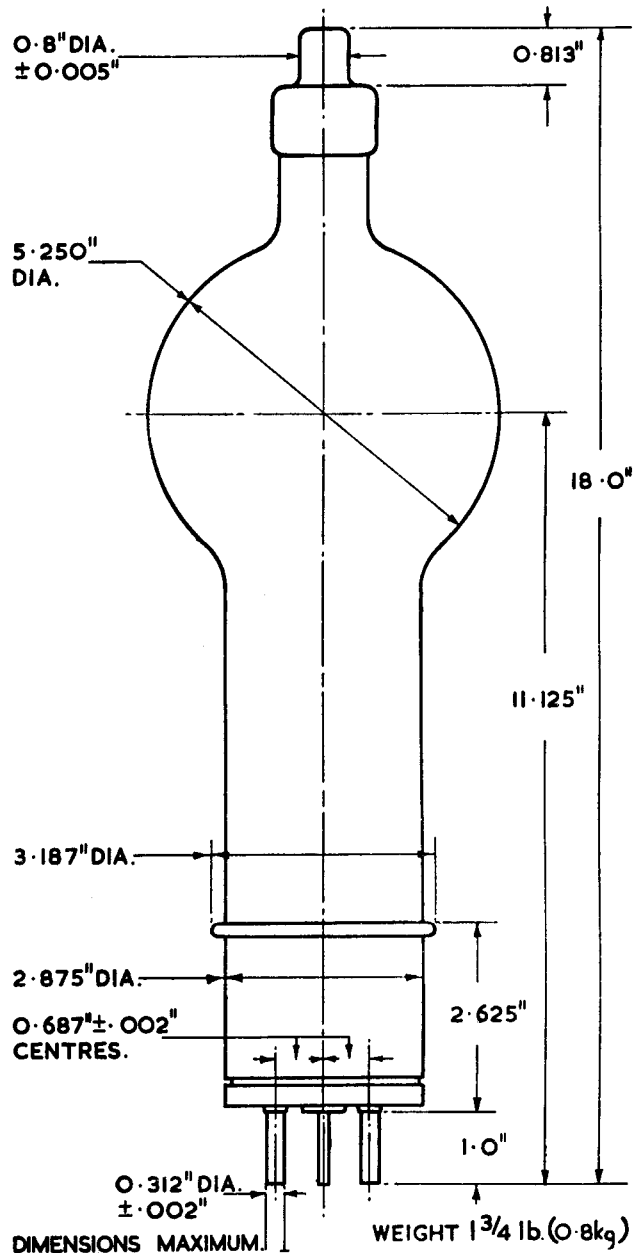

MARCONI'S WIRELESS TELEGRAPH COMPANY LIMITED

Head Office: Marconi House, Chelmsford, England. Telephone: Chelmsford 3221. Telegraphic Address: Expanse, Chelmsford

the rectifier must not be fitted into a tube nor must any obstruction be allowed to impede the free air circulation around the valve.

Recommended Method of Applying Air Blast

It is recommended, for both the above conditions of operation, that a $\frac{1}{4}$ -in. bore air pipe be used to deliver the air blast at a pressure of $\frac{1}{2}$ in. water gauge. The air tube should include a section of insulating material at least 12 in. long to avoid the danger of a flash-over between the filament cap and earth.

Pre-heating of Filament

The mercury condensation temperature is raised approximately 20°C above the ambient temperature in free air by the power dissipated in the cathode.

The pre-heating time required to raise the condensation temperature to its working value is given in the following table. No anode potential may be applied before this time has elapsed. The table is applicable when either of the recommended types of air blast is used. The power supplied to the air blower (and heater, if used) should be switched simultaneously with the filament supply.

Ambient temperature (°C)	Pre-heating Time (Minutes)
20 or over	2
15 or over	14
10 or over	20
5 or over	30

APPROXIMATE DATA

V_f	5	V
I_f	19 ± 2	A
$I_{a(pk)} (max)$	(a) 8 A (b) 14	A
$I_a (av) (max)$	(a) 2 A (b) 3.5	A
PIV (max)	16	kV
T_{Hg}	25–45°	C

Maximum Outputs

(1) 3-phase full-wave		
$V_{dc} (max)$	15	kV
$I_{dc} (max)$	(a) 5.5 A (b) 10	A
(2) 3-phase half-wave		
$V_{dc} (max)$	7.5	kV
$I_{dc} (max)$	(a) 5.5 A (b) 10	A

NOTES

1. The valve must be screened against HF fields.
2. If a large smoothing capacitor is used, care should be taken not to exceed the maximum peak anode current.
3. Care must be taken to see that there is no mercury condensation round the anode seal.
 - (a) Filament voltage in phase with anode current.
 - (b) Filament voltage 60°–120° out of phase with the anode current.