



AH314

2.3-2.9 GHz WiMAX 2W Driver Amplifier

Product Features

- 2.3 – 2.9 GHz
- 23 dB Gain
- EVM <2.5 % @ 24 dBm Pout
- Internal Active Bias
- +5V Single Supply Voltage
- +33 dBm P1dB
- Lead-free/RoHS-compliant 5x5 mm QFN SMT package

Applications

- 802.16 WiMAX infrastructure
- WiBro infrastructure

Product Description

The AH314 is a high dynamic range broadband driver amplifier in a surface mount package. The two-stage amplifier has 23 dB of gain, while achieving +24 dBm of linear output power for 2.3–2.9 GHz WiMAX/WiBro applications.

AH314 uses a high reliability +5V InGaP/GaAs HBT process technology. The device incorporates proprietary bias circuitry to compensate for variations in linearity and current draw over temperature. The device does not require any negative bias voltage; an internal active bias allows the AH314 to operate directly off a commonly available +5V supply. The RoHS-compliant/Lead-free 5x5mm QFN package is surface mountable to allow for low manufacturing costs to the end user.

The AH314 is targeted for use in a configuration for the driver stage amplifier in 802.16 WiMAX or WiBro basestations where high linearity and medium power is required.

Functional Diagram

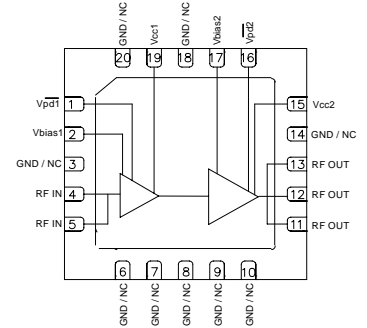

Specifications ⁽¹⁾

Parameter	Units	Min	Typ	Max
Operational Bandwidth	GHz	2.3		2.9
Output Channel Power	dBm		+24	
Power Gain	dB		23	
EVM ⁽²⁾	%		2.0	2.5
Efficiency	%		6.6	
Output P1dB	dBm		+33	
Noise Figure	dB		6.4	
PIN_VPD Current, I _{pd}	mA		36	
Quiescent Current, I _{cc} ⁽³⁾	mA		600	
I _{cc} @ 24dBm	mA		700	
Device Voltage, V _{cc}	V		+5	

1. Test conditions unless otherwise noted: 25°C, +5V V_{supply}, in 2.5-2.7GHz tuned application circuit shown in page 3.
2. Using an 802.16-2004 OFDMA, 64QAM-1/2, 1024-FFT, 20 symbols, 30 subchannels.
3. This corresponds to the quiescent current or operating current under small-signal conditions with bias resistor R1=68Ω off pin 1 and R2=150Ω off pin 16.
4. This corresponds to the quiescent current or operating current under small signal conditions into pins 1, 2, 15 and 17. Pin 1 and 16 is used a reference voltage for the internal biasing circuitry. It is expected that PIN_VPD1 and PIN_VPD2 will pull 36 mA of current when used with series resistors (i.e. Total device current typically will be 636 mA).

Typical Performance ⁽⁴⁾

Parameter	Units	V _{cc} =5V	V _{cc} =6V
Frequency	GHz	2.6	2.6
Output Channel Power	dBm	+25	+26.5
Power Gain	dB	23.1	23.1
S11 – Input R.L.	dB	-8.2	-8.6
S22 – Output R.L.	dB	-16.7	-26
Output P1dB	dBm	33	34.5
EVM	%	1.8	2.2
Efficiency	%	8.2	8.5
Noise Figure	dB	6.4	6.4
Quiescent Current	mA	600	650
V _{pd} , V _{bias}	V	+5	+6

4. Typical parameters reflect performance in a tuned application circuit at +25°C.

Absolute Maximum Rating

Parameter	Rating
Storage Temperature	-55 to +125 °C
Collector Current, I _{cc} (I _{cc1} +I _{cc2})	1.6 A
RF Input Power into a 50Ω Load	19 dBm
Device Voltage	+8 V
Device Power	8 W
Thermal Resistance, R _{th}	14.4 °C / W
Junction Temperature	150 °C

Operation of this device above any of these parameters may cause permanent damage.

Ordering Information

Part No.	Description
AH314-G	2.3-2.9 GHz WiMAX 2W Driver Amplifier
AH314-PCB	2.4-2.7 GHz Evaluation Board

Standard T/R size = 500 pieces on a 7" reel.

Specifications and information are subject to change without notice.



AH314

2.3-2.9 GHz WiMAX 2W Driver Amplifier

Typical Device Data

S-Parameters ($V_{CC} = +5\text{ V}$, $I_{CC} = 600\text{ mA}$, $T = 25\text{ }^{\circ}\text{C}$, calibrated to device leads)

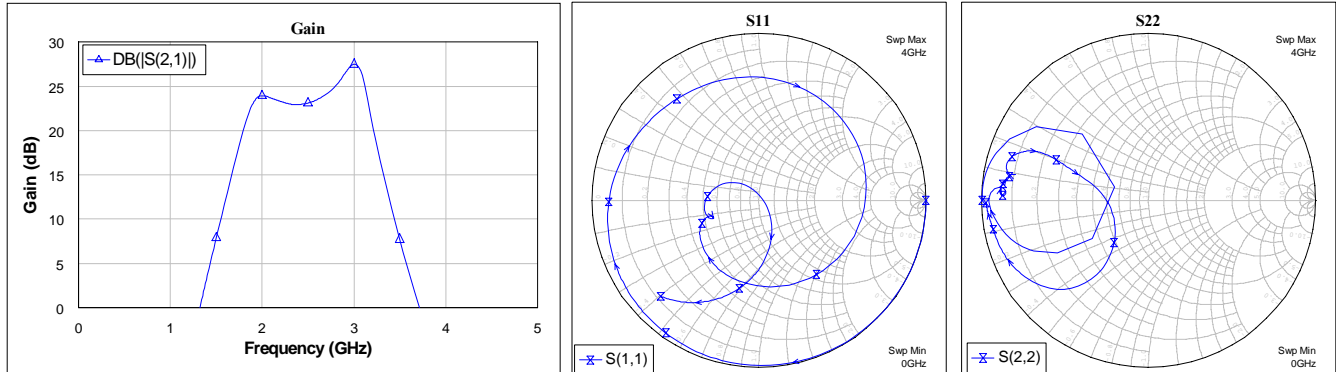

Notes:

The gain for the unmatched device in 50ohm system is shown as the trace in blue color. The impedance plots are shown from 0 – 4000 MHz, with markers placed at 0-4GHz in 0.5GHz increments.

S-Parameters ($V_{CC} = +5\text{ V}$, $I_{CC} = 600\text{ mA}$, $T = 25\text{ }^{\circ}\text{C}$, unmatched 50 ohm system, calibrated to device leads)

Freq (MHz)	S11(dB)	S11(ang)	S21(dB)	S21(ang)	S12(dB)	S12(ang)	S22(dB)	S22(ang)
2200	-6.45	-120.54	23.31	-145.39	-48.04	60.39	-2.33	157.17
2250	-6.78	-130.36	23.13	-158.46	-47.97	52.65	-2.65	156.54
2300	-7.13	-138.36	22.99	-170.95	-48.01	45.37	-2.98	156.14
2350	-7.45	-144.94	22.95	177.21	-48.10	38.67	-3.31	155.90
2400	-7.81	-150.37	22.95	165.61	-48.27	31.91	-3.65	155.85
2450	-8.23	-154.71	23.00	154.08	-48.56	24.85	-4.01	155.98
2500	-8.68	-158.06	23.09	142.57	-48.96	17.33	-4.39	156.31
2550	-9.18	-160.55	23.28	131.04	-49.41	8.81	-4.78	156.65
2600	-9.69	-161.94	23.51	119.35	-49.99	-0.931	-5.19	157.1
2650	-10.16	-162.13	23.78	107.23	-50.72	-12.17	-5.65	157.78
2700	-10.53	-161.30	24.11	94.68	-51.59	-26.06	-6.17	158.54
2750	-10.73	-159.84	24.53	81.54	-52.51	-43.81	-6.8	159.55
2800	-10.68	-158.59	25.03	67.41	-53.25	-67.29	-7.77	161.17
2850	-10.36	-158.56	25.69	52.45	-53.15	-96.50	-9.09	164.03
2900	-9.90	-161.62	26.43	35.26	-51.90	-128.68	-11.10	172.59
2950	-9.64	-169.83	27.14	14.38	-49.90	-160.49	-12.82	-160.65
3000	-10.22	175.73	27.49	-10.77	-48.05	168.76	-9.754	-129.23

Device S-parameters are available for download from the website at: <http://www.wj.com>

Application Circuit PC Board Layout

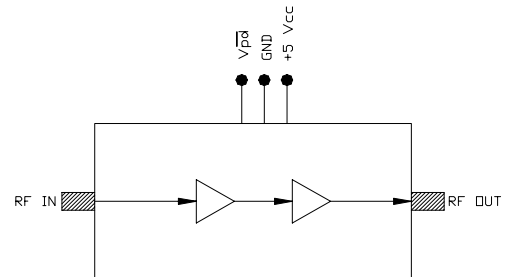
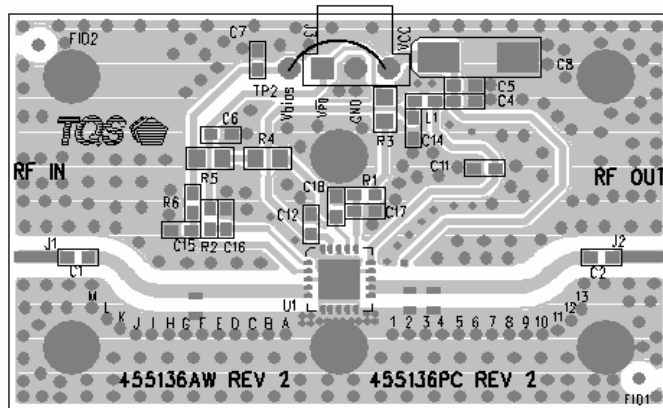

PCB Material: 0.0147" Rogers Ultralam 2000, single layer, 1 oz Cu, $\epsilon_r = 2.45$ Microstrip line details: width = .042", spacing = .050". The silkscreen markers 'A', 'B', 'C', etc. and '1', '2', '3', etc. are used as place markers for the input and output tuning.



AH314

2.3-2.9 GHz WiMAX 2W Driver Amplifier

Application Circuit Schematic (AH314-PCB) for 2.5-2.7 GHz. (The Amplifier can be tuned across any 200MHz band over the 2.3-2.9 GHz BW.)

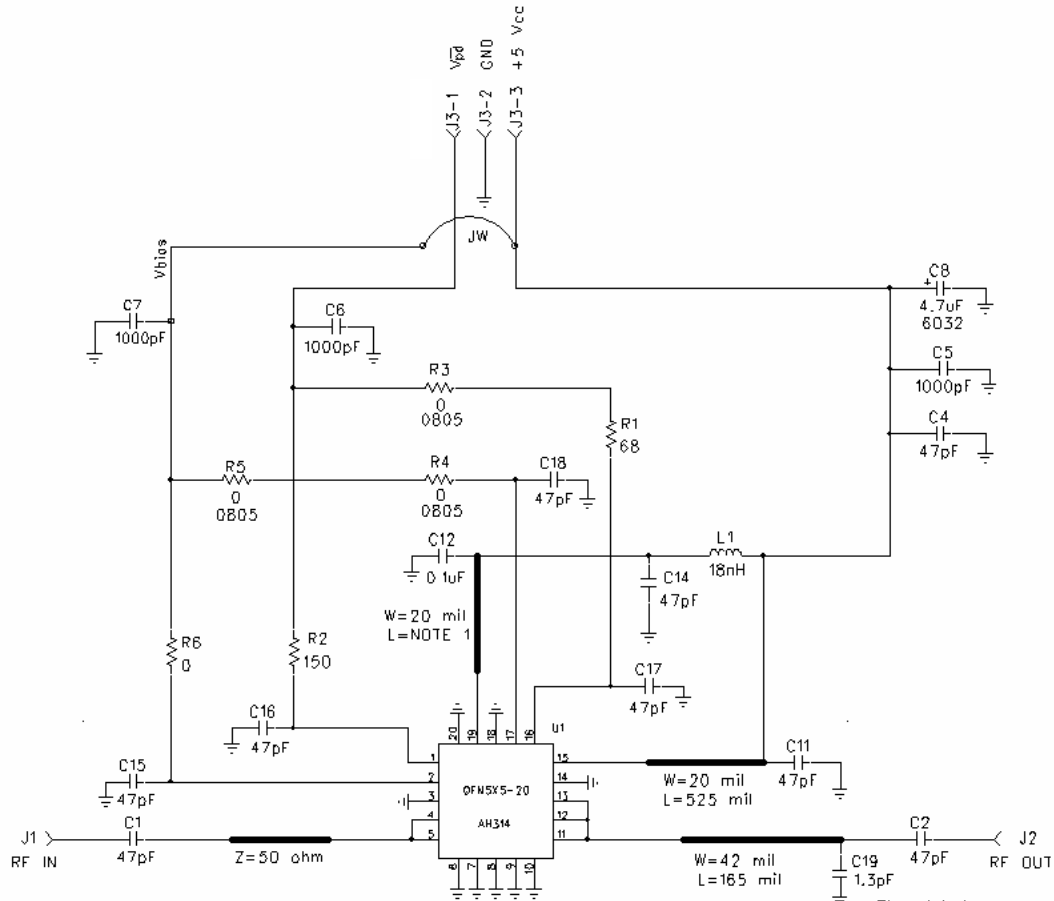

Note 1: C12 to be placed as close as possible to the device.

Note 2: C11=47pF is critical. Do not replace with other value.

Placed between marking 3-4.



AH314

2.3-2.9 GHz WiMAX 2W Driver Amplifier

Typical Performance Plots for AH314-PCB, Vpd, Vbias, Vcc = 5V, +25°C

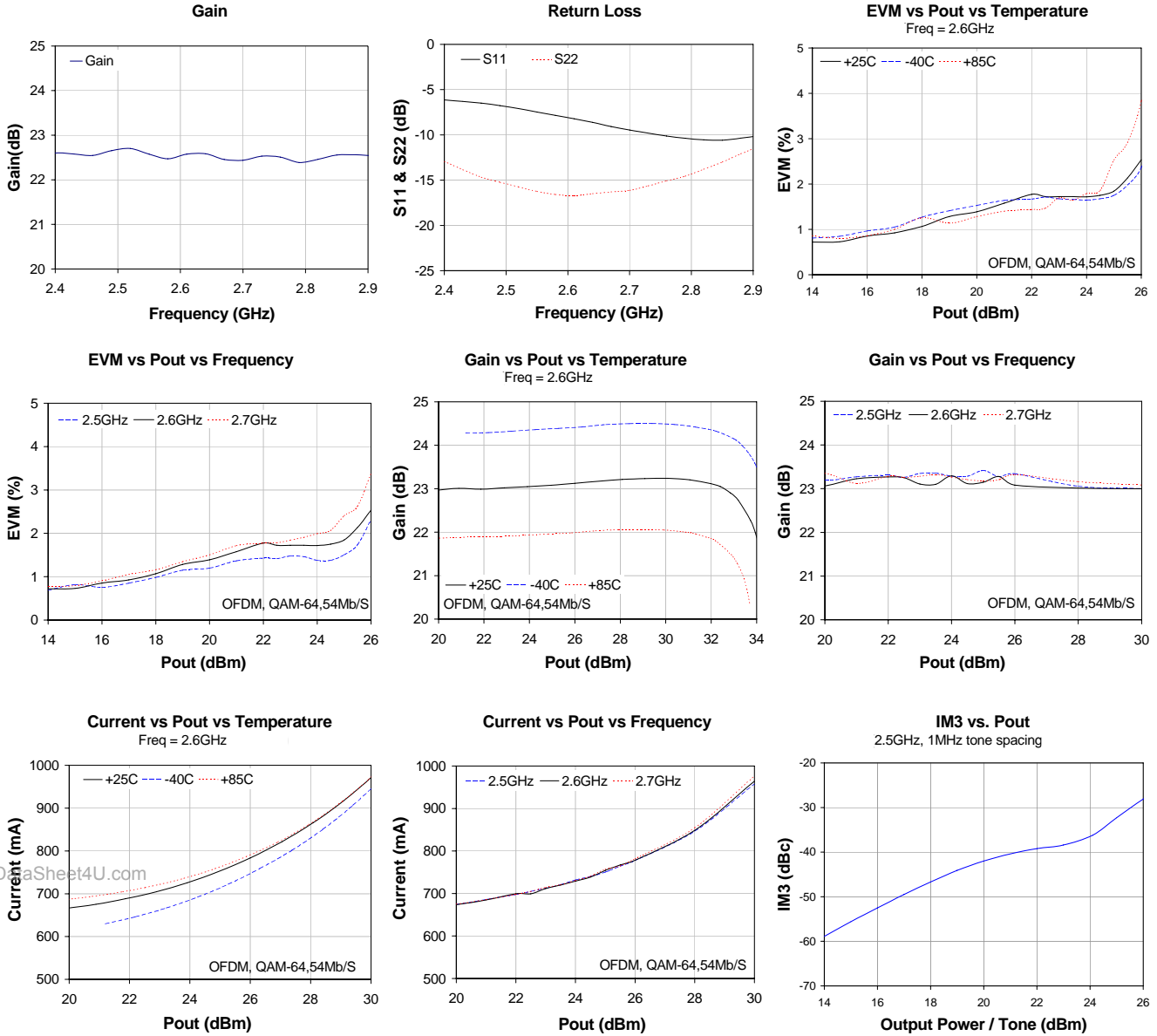

Typical Performance Plots for AH314-PCB, Vpd, Vbias = 5V, Vcc = 6V, +25°C

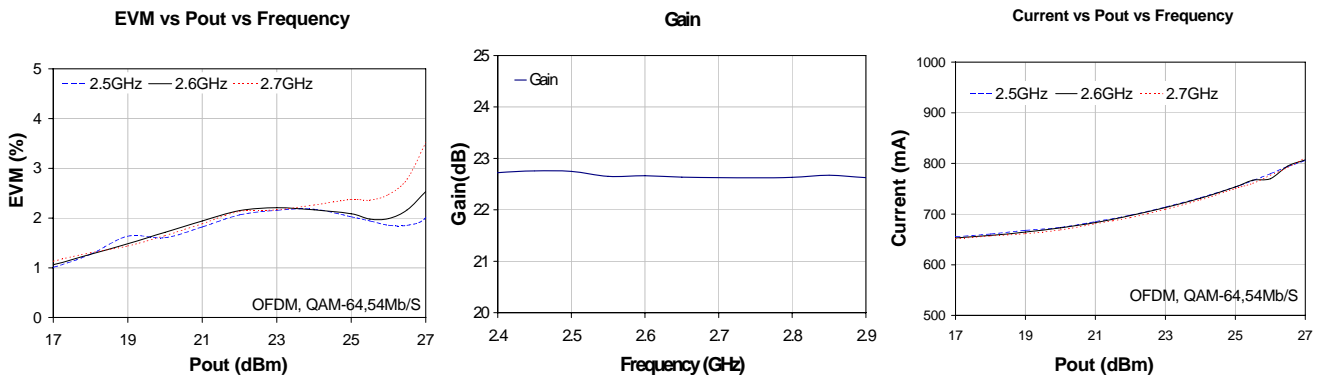

Specifications and information are subject to change without notice.



AH314

2.3-2.9 GHz WiMAX 2W Driver Amplifier

2.3 – 2.7 GHz Application Note: Changing Icq Biasing Configurations at +5V

The AH314 can be configured to operate with lower bias current by varying the bias-adjust resistors R1 & R2. R1 sets the quiescent current in the output stage, while R2 sets the quiescent current in the input stage. The recommended circuit configurations shown previously in this datasheet have the device operating with a 600 mA as the quiescent current (I_{CQ}). This biasing level represents a tradeoff in terms of EVM and efficiency. Lowering I_{CQ} will improve upon the efficiency of the device, but degrade the EVM performance. Raising I_{CQ} will improve the EVM performance, but degrade the efficiency of the device. Measured data shown in the plots below represents the AH314 measured and configured for 2.6 GHz applications. It is expected that variation of the bias current for other frequency applications will produce similar performance results.

Table 1 : Reduced Current Operation

I _{cq} (mA)	R1 (Ω)	R2 (Ω)	V _{PD} , V _{bias} , V _{cc} (V)
600	68	150	5
500	86	180	5
400	110	300	5
300	160	330	5

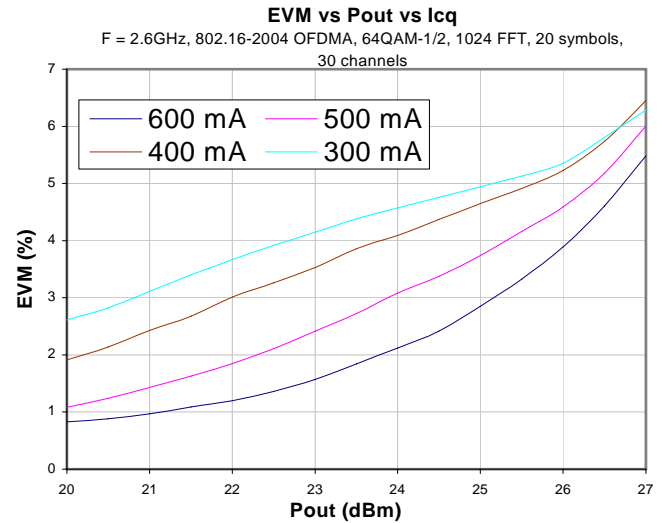

2.3 – 2.7 GHz Application Note: Changing Icq Biasing Configurations at +3.3V

www.DataSheet4U.com

Table 2 : Reduced Current Operation

I _{cq} (mA)	R1 (Ω)	R2 (Ω)	V _{PD} , V _{bias} , V _{cc} (V)
500	3	3	3.3
400	11	15	3.3
350	17	24	3.3
250	43	45	3.3

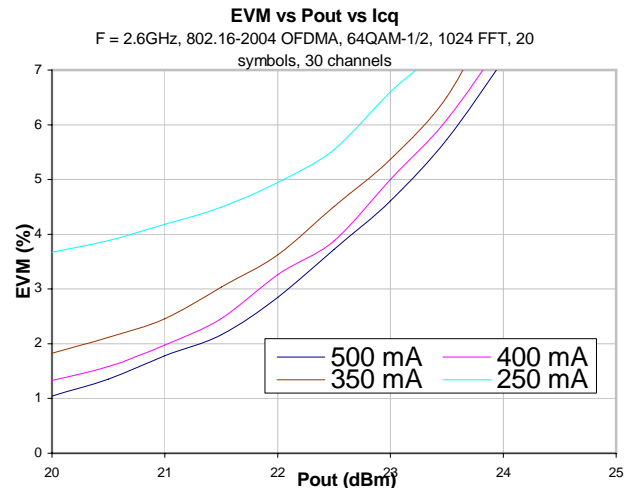



AH314

2.3-2.9 GHz WiMAX 2W Driver Amplifier

Mechanical Information

This package is lead-free/RoHS-compliant. The plating material on the pins is annealed matte tin over copper. It is compatible with both lead-free (maximum 260 °C reflow temperature) and leaded (maximum 245 °C reflow temperature) soldering processes.

Outline Drawing

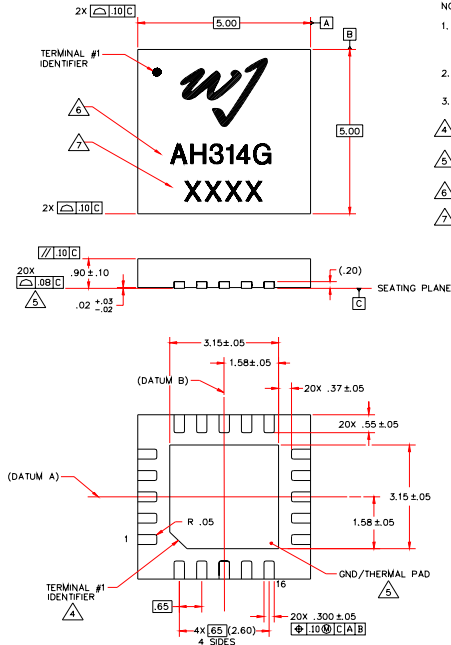

Mounting Configuration / Land Pattern

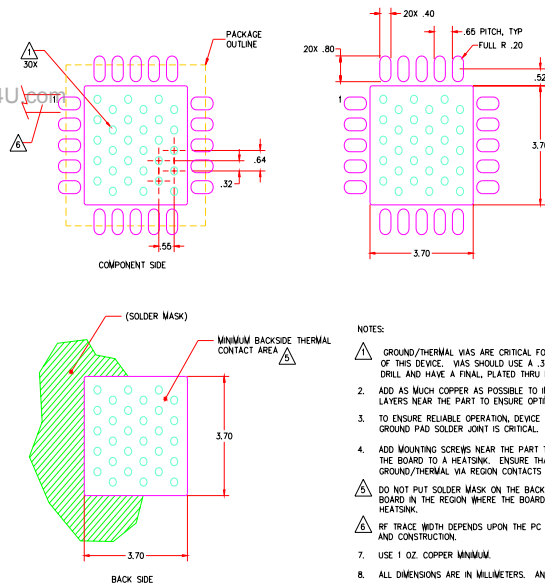

Product Marking

The component will be marked with an "AH314G" designator with an alphanumeric lot code on the top surface of the package.

Tape and reel specifications for this part are located on the website in the "Application Notes" section.

ESD / MSL Information



Caution! ESD sensitive device.

ESD Rating: Class 1B
 Value: Passes $\geq 500V$ to $<1000V$
 Test: Human Body Model (HBM)
 Standard: JEDEC Standard JESD22-A114

ESD Rating: Class IV
 Value: Passes $\geq 1000V$ to $<2000V$
 Test: Charged Device Model (CDM)
 Standard: JEDEC Standard JESD22-C101

MSL Rating: Level 3 at $+260^\circ C$ convection reflows
 Standard: JEDEC Standard J-STD-020

Functional Pin Layout

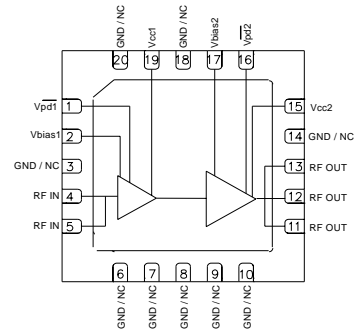

Function	Pin No.
Vcc1	19
Vcc2	15
V _{pd1}	1
V _{pd2}	16
Input	4,5
Output	11,12,13
V _{bias1}	2
V _{bias2}	17
GND	Backside Paddle
N/C or GND	3,6,7,8,9,10,14,18,20