

Introduction

AH401, designed with Bipolar technology, includes on-chip Hall element voltage generator, a voltage regulator for operation with supply voltages of 4.5 to 60V, reverse voltage protection, temperature compensation circuitry, small-signal amplifier, Schmitt trigger and an open-collector output.

The sensor is designed to respond to North and South poles. While the magnetic flux density(B) is larger than operate point Bop, the output will be turned on with low output level. Then the output is held until the magnetic flux (B) is lower than release point Brp. The output will be turned off with high output level.

AH401 offers a variety of packages, including TO-92, SOT-23. All packages are RoHS compliant.

Features

- Miniature construction
- High sensitivity of +/-55 Gauss (typ.)
- Wide voltage range of 4.5 Vdc to 60 Vdc
- Temperature range of -40 °C to 150 °C
- Open Collector Output

Applications

- BLDC Motor Commutation
- Flow sensor
- Position sensor
- Speed sensor
- Proximity sensor

Function diagram

AH401, designed with Bipolar technology, includes on-chip Hall element voltage generator, a voltage regulator for operation with supply voltages of 4.5 to 60V, reverse voltage protection, temperature compensation circuitry, small-signal amplifier, Schmitt trigger and an open-collector output.

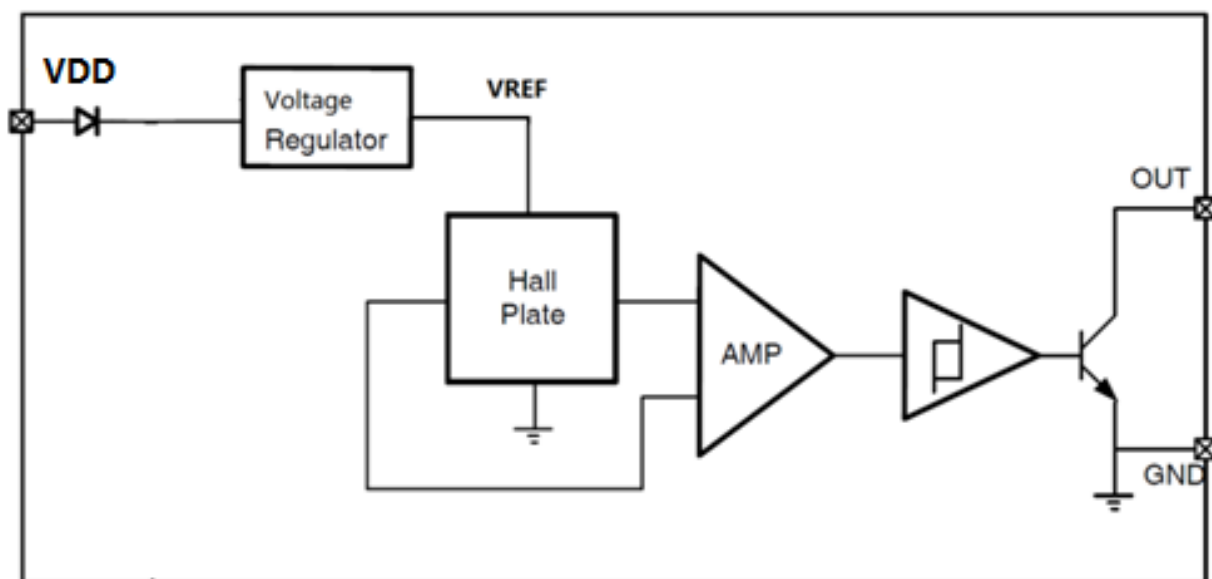

AH401

High Voltage Hall Effect Switch Sensor

Vinbelltech Co. Ltd



Pin orientation

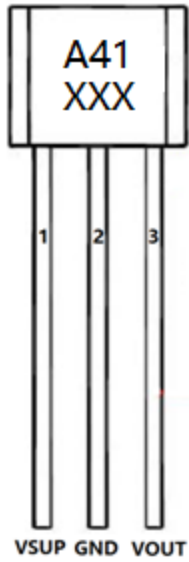

TO92S

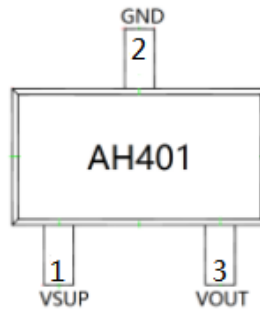

Sot23-3L

Ordering information

Part number	Package	Packing	Ambient, T _A	BOP	Brp
AH401UA	TO92S	Bulk, 1000 pieces/bag	-40°C to 150°C	55 Gauss	-55 Gauss
AH401SU	SOT23	Tape&Reel, 3000 pieces/reel	-40°C to 150°C	55 Gauss	-55 Gauss

Pin assignment

SOT23-3LPin number	TO92SPin number	Name	Function
1	1	VSUP	供电电压 4.5V 至 60V
2	2	GND	地线
3	3	VOUT	集电极开路输出，需接上拉电阻

Absolute Maximum Ratings

The absolute maximum value is the limiting value when the chip is applied, above which the chip can be damaged. Although the function of the chip is not necessarily damaged when the absolute maximum value is exceeded, the reliability of the chip may be affected if the absolute maximum value is exceeded for a certain time.

Parameter	Symbol	Min	Max	Units
Supply voltage	VDD	-60	95	V
Reverse voltage	Vout	-0.5	70	V
Output Sink Current	I _{sink}	0	40	mA
Operating temperature range	T _a	-40	150	°C
Storage temperature range	T _s	-50	165	°C

Electrical and magnetic characteristics (Ta=25°C, VDD =5.0V)

Parameter	Symbol	Test Conditions	Min	Typ	Max	Units
Electrical characteristics						
VDD	Operating voltage		4.5		60	V
IDD	Supply current			3.5	7	mA
I _{le}	Leakage current	Off condition			10	uA
V _{sat}	Saturation voltage output	I _{out} =20mA, On condition			0.4	V
T _r	Output rising time	Pullup resistor =1kohms, Load cap=20pF			1	uS
T _f	Output falling time	Pullup resistor =1kohms, Load cap=20pF			1.5	uS
Magnetic characteristics						
B _{op}	Operate point	Pullup resistor =1kohms, Load cap=20pF	10	55	110	Gauss
B _{rp}	Release point	Pullup resistor =1kohms, Load cap=20pF	-110	-55	-10	Gauss
B _{hys}	Hysteresys	Pullup resistor =1kohms, Load cap=20pF		110		Gauss

Output Behavior

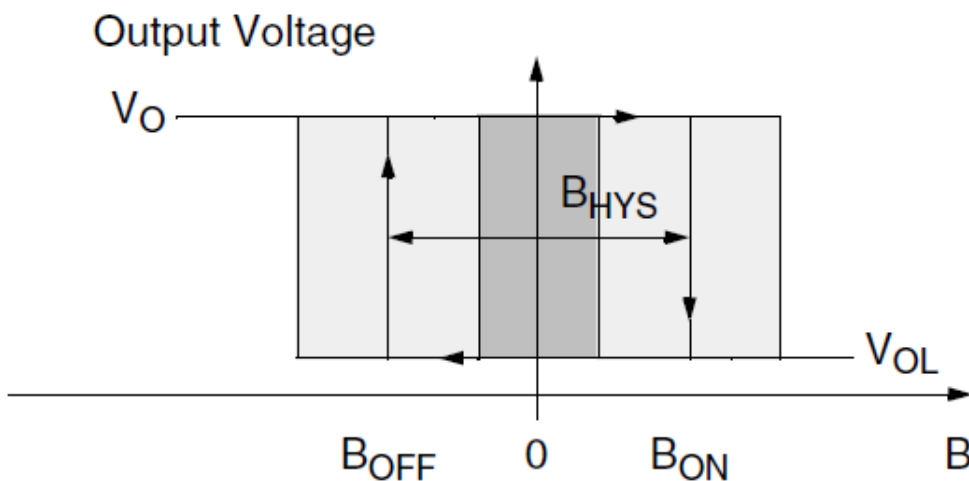

AH401UA/SU output behavior

Application Circuits

Typical application circuit (see the following circuit) $R_L = 4700$ ohms

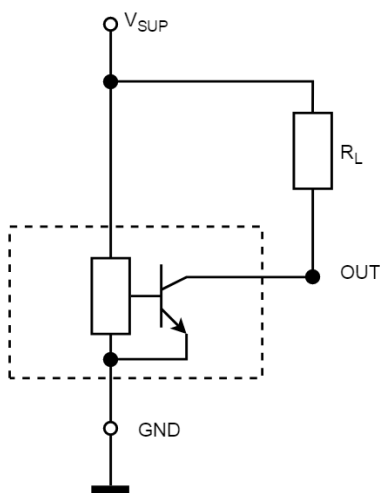

Case 1 of typical application circuit

T092S dimensions

symbol	Size (mm)		Size (in inches)	
	minimum	maximum	minimum	maximum
A	1.42	1.67	0.056	0.066
A1	0.66	0.86	0.026	0.034
b	0.35	0.56	0.014	0.022
b1	0.4	0.55	0.016	0.022
C	0.36	0.51	0.014	0.02
D	3.9	4.2	0.154	0.165
D1	2.97	3.27	0.117	0.129
E	2.9	3.28	0.114	0.129
e	1.270 TYP		0.050 TYP	
e1	2.44	2.64	0.096	0.104
L	13.5	15.5	0.531	0.61
x	2.025TYP		0.080TYP	
y	1.545TYP		0.061TYP	
z	0.500TYP		0.020TYP	
θ	45°TYP		45°TYP	

SOT23

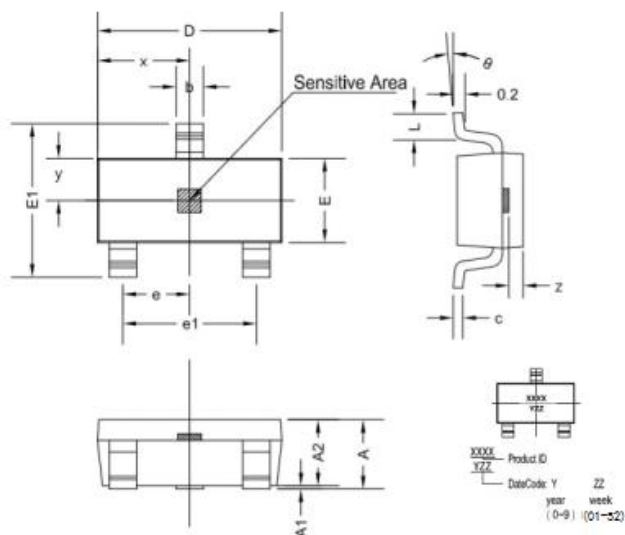

SOT23 dimensions

symbol	Size (mm)		Size (in inches)	
	minimum	maximum	minimum	maximum
A	1.05	1.25	0.041	0.049
A1	0	0.1	0	0.004
A2	1.05	1.15	0.041	0.045
b	0.3	0.5	0.012	0.02
c	0.100	0.2	0.004	0.008
D	2.82	3.02	0.111	0.119
E	1.5	1.7	0.059	0.067
E1	2.65	2.95	0.104	0.116
e	0.950 TYP		0.037 TYP	
e1	1.8	2	0.071	0.079
L	0.3	0.6	0.012	0.024
x	1.460TYP		0.057TYP	
y	0.800TYP		0.032TYP	
z	0.600TYP		0.024TYP	
θ	0°	8°	0°	8°

Copyright ©2018, Vinbelltech Co. Ltd

Vinbelltech Co. Ltd reserves the right to make, from time to time, such departures from the detail specifications as may be required to permit improvements in the performance, reliability, or manufacturability of its products. Before placing an order, the user is cautioned to verify that the information being relied upon is current.

Vinbelltech's products are not to be used in any devices or systems, including but not limited to life support devices or systems, in which a failure of Vinbelltech's product can reasonably be expected to cause bodily harm.

The information included herein is believed to be accurate and reliable. However, Vinbelltech Co. Ltd assumes no responsibility for its use; nor for any infringement of patents or other rights of third parties which may result from its use.